

INSTRUCTION AND PARTS BOOK NO. 94-4
FOR

MEYER

STEEL BUNK FEEDER



DO NOT OPERATE EQUIPMENT UNTIL THIS MANUAL HAS BEEN READ AND UNDERSTOOD.

MEMBER



Manufactured by
Meyer Mfg. Corp.

County Hwy. A West
P.O. Box 405
Dorchester, Wisconsin 54425-0405
Phone 715-654-5132 • FAX 715-654-5513
1-800-325-9103
www.meyermfg.com
E-mail: sales@meyermfg.com



Over
60 years
of service
to our customers

TABLE OF CONTENTS

Table Of Contents	2
Introduction	3
Safety First	4
Safety Precautions	4
Operation	5
Adjustment	5
Lubrication	5
Assembly	6
Prepare For Assembly	7
Pivot Sides Into Position And Install Center Braces	7
Install End Panels	7
Install Wheels And Hitch	7
Final Assembly	8
Assemble As Bale Transporter	8
Repair Parts	9

INTRODUCTION

Congratulations on your purchase of a new Meyer farm equipment product. Undoubtedly you have given much consideration to your purchase and we're proud that you have selected Meyer. Pride in craftsmanship, engineering and customer service have made Meyer products the finest in the farm equipment industry today.

There is no substitute for quality. That is why thousands of people like you have purchased Meyer farm equipment. They felt it was the best equipment to serve their farming needs, now and in years to come. We ask that you follow our policy of "safety first," and we strongly suggest that you read through the owner's manual before operating your Meyer farm equipment.

Meyer Manufacturing Corporation wants to thank you for not compromising quality. We are determined to offer excellence in customer service as well as provide you with the very best value for your dollar.

REMEMBER:

**FARM EQUIPMENT BUYERS
TRUST THE NAME MEYER!**

Sincerely,

All Employees of
MEYER MANUFACTURING CORPORATION

Meyer Mfg. Corp. reserves the right to make improvements in design, or changes in specifications at any time, without incurring any obligation to owners of units previously sold.

This supersedes all previous published instructions.

At the back of this manual is the repair parts section. All replacement parts are to be obtained from or ordered through your Meyer dealership. When ordering repair parts, refer to the parts section and give complete information including quantity, correct part number, detailed description and even Model No. and Serial No. of the bunk feeder which needs repair parts.

NOTE: All references to right hand (RH) , left hand (LH), front and rear apply to the product as viewed from the rear of the bunk feeder.



SAFETY FIRST



A brief definition of signal words that are used in this manual is as follows:



DANGER indicates an imminently hazardous situation which, if not avoided, WILL result in death or serious injury.



WARNING indicates a potentially hazardous situation which, if not avoided, COULD result in death or serious injury, and includes hazards that are exposed when guards are removed..



CAUTION indicates a potentially hazardous situation which, if not avoided, MAY result in minor or moderate injury. It is also used to alert against unsafe practices.

SAFETY PRECAUTIONS

Inspect When First Delivered And Regularly Thereafter; That All Connections And Bolts Are Tight And Secure Before Operating.

Do Not Tow At Speeds In Excess Of 10 Mph.

You Must Observe All Applicable Traffic Laws When Transporting On Public Roadways (where Legal To Do So).

Check Local Laws For All Highway Lighting And Marking Requirements.

Always Install A SMV Emblem On Rear Of Unit For Transporting On Roadways And Keep This Emblem Clean.

FAILURE TO HEED MAY RESULT IN SERIOUS PERSONAL INJURY OR DEATH.

OPERATION

1. After unhitching the feeder, pivot the tongue to a vertical position and secure by hooking S-hook on chain weldment around tongue and back to chain link.

2. For convenience, a telescoping hitch is provided. The hitch can be unlatched and extended out for easy hook up to the tractor or implement drawbar. Be sure to lock the hitch by backing up until it latches; before proceeding forward.



WARNING: IF TRANSPORTING UNIT ON PUBLIC ROADWAY, INSTALL A SMV SIGN INTO SOCKET ON REAR PANEL. KEEP THIS SIGN AND THE TWO REFLECTIVE DECALS CLEAN. FAILURE TO HEED MAY RESULT IN SERIOUS PERSONAL INJURY OR DEATH.



WARNING: YOU MUST OBSERVE ALL APPLICABLE TRAFFIC LAWS WHEN

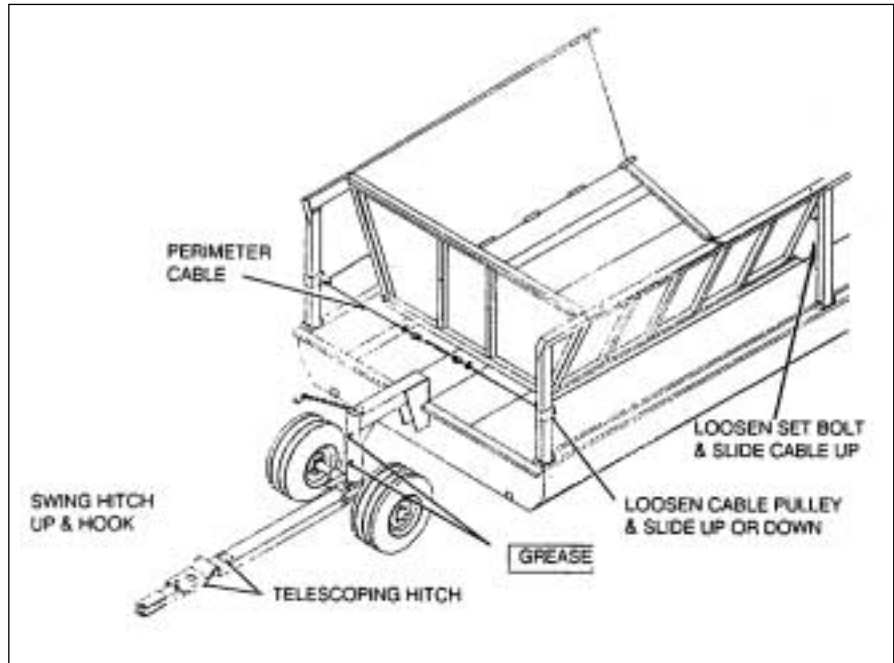

FIGURE 1

TRANSPORTING ON PUBLIC ROADWAYS (WHERE LEGAL TO DO SO). CHECK LOCAL LAWS FOR ALL HIGHWAY LIGHTING AND MARKING REQUIREMENTS. FAILURE TO HEED MAY RESULT IN SERIOUS PERSONAL INJURY OR DEATH.

ADJUSTMENT

The perimeter cable height is adjustable to accommodate different livestock sizes.

1. Where the cable passes through each upright on the side assemblies, loosen but do not remove the set bolt over the adjusting slot. Slide cable up or down and retighten. See Figure 1.
2. At each of the 4 corner posts, loosen the cable pulley weldment and slide up or down. Retighten.
3. Using the turnbuckle, tighten the cable annually to reduce wear.

LUBRICATION

1. Grease the two fittings on the front steering pivot post monthly. See Figure 1 .
2. Repack all wheel hub bearings annually.
3. For 30 ft. feeders and 24 ft. feeders with optional tandem axle, grease the fitting on the two tandem beams monthly. See Figure 3.

ASSEMBLY

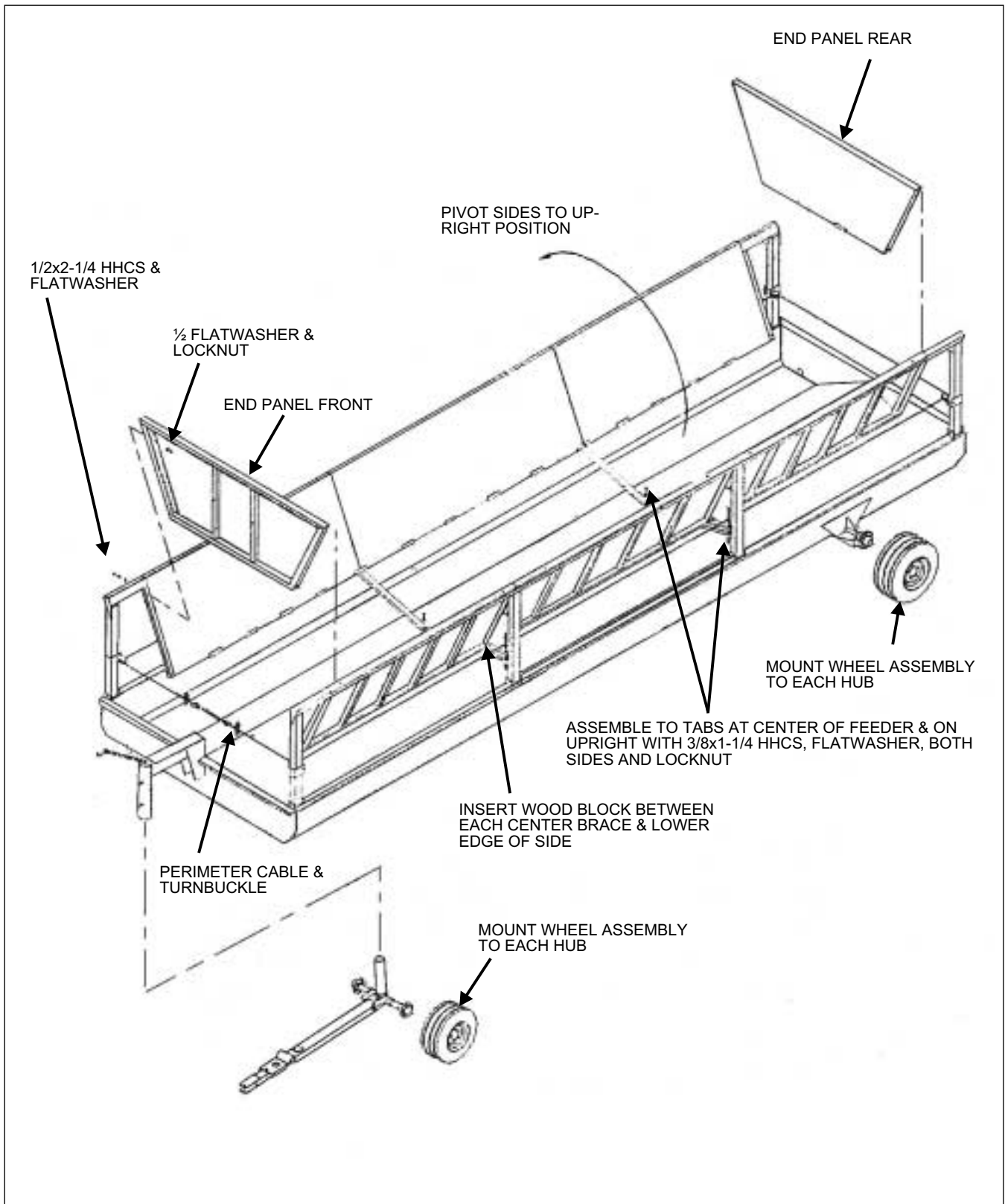

FIGURE 2

PREPARE FOR ASSEMBLY (See Figure 2)

The feeder is shipped with subassemblies packaged inside the unit. Lift out the front steering assembly, the two end panels, and the center support braces.

PIVOT SIDES INTO POSITION AND INSTALL CENTER BRACES

1. Set up one side at a time. Pivot the side to an upright position. Securely hold side in position by having other persons hold it or use a hoist (loader, etc.) to hold it.
2. Install a center brace to each tab welded to the raised center of feeder bottom. The brace is installed with the channel legs facing down; the cropped corners toward the center of the feeder and bolts inserted from the top. The outer end of brace attaches over the tab welded to the upright on the side frame. Do not tighten braces at this time.



WARNING: NEVER REACH UNDER A VERTICAL SIDE FROM THE OUTSIDE TO INSTALL CENTER BRACES. IF THE SIDE SHOULD FALL YOU WILL BE CRUSHED IN THE PINCH POINT. FAILURE TO HEED MAY RESULT IN SERIOUS PERSONAL INJURY OR DEATH.

3. If a 1" thick block of wood is inserted between the top surface of the braces and lower edge of the sides, it will improve alignment to install the end panels between the sides in the next step.

INSTALL END PANELS

1. Install end panels with sheet metal toward inside. **NOTE** that the rear panel has reflective decals and a SMV sign socket on it.

2. Remove the loosely assembled bolts, flat washers and lock nuts from the ends of the sides where the end panels will bolt.

3. Install the end panels inside the taper created by the two sides. Pound with wood block or mallet on top edge of end panel until bolts can be reinstalled, loosely. Bolts are inserted from outside with flat washers on each side. Continue to bump panels until they are flush with sides. Tighten bolts.

4. Remove 1" wood blocks and tighten center braces.

INSTALL WHEELS AND HITCH

1. On 30 ft. feeders and 24 ft feeders with optional tandem axle, assembly the tandem walking beam to the axle tube (See Figure 3).

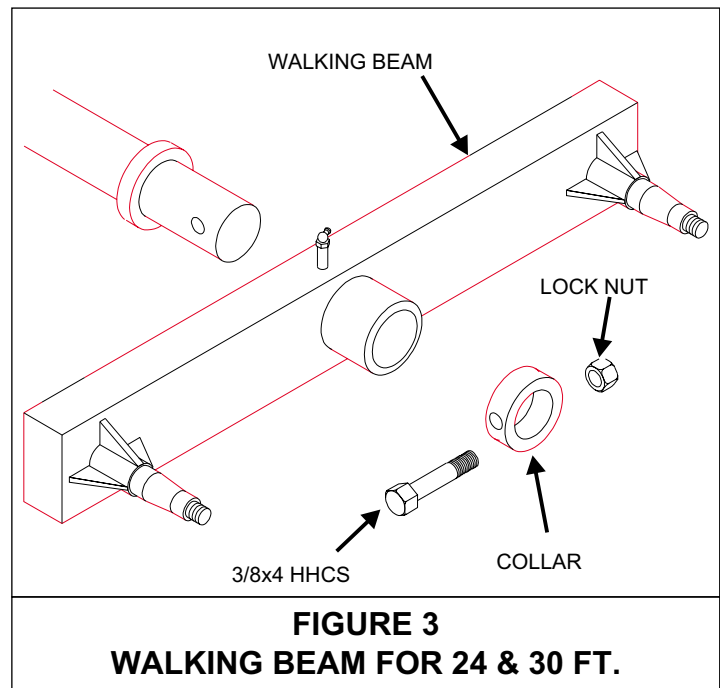

2. Assemble the wheel assemblies to the rear axle hubs. Mount with valve stems facing to inside.

3. Lift the front of the feeder and slide hitch weldment tube into the tube welded to the front

of the feeder. Assemble wheel assemblies to each hub on the hitch. Mount with valve stems facing to inside.

FINAL ASSEMBLY

1. If necessary, adjust the cable height around the perimeter of the feeder as described in Adjustments section.
2. Remove all slack from the cable at the front by strongly pulling the slack forward and tightening the turnbuckle. Correct tension is when you can only deflect the cable about $\frac{1}{2}$ by pulling on it.
3. Lubricate the unit as described in Lubrication section.

ASSEMBLE AS BALE TRANSPORTER

(See Figure 4.)

1. The feeder can be used as a round bale transporter. Following the safety precautions previously outlined, remove the end panels and the center braces from the feeder. Carefully pivot the sides back into the bottom of the feeder.
2. Place 4x4x10' wood beams across the frame of the feeder. corresponding with the predrilled holes along the edges of the frame. Fasten to frame with $\frac{3}{8}$ bolts and nuts.
3. A kit is available from the manufacturer including wood beams and hardware ready to install. If you choose to fabricate your own beams, use suitable beams and drill for $\frac{3}{8}$ bolts to fasten to factory drilled holes along the edges of the frame.
4. Round bales can be loaded between the wood beams from each side of the feeder.



**FIGURE 4
BALE TRANSPORTER**

REPAIR PARTS

HUB

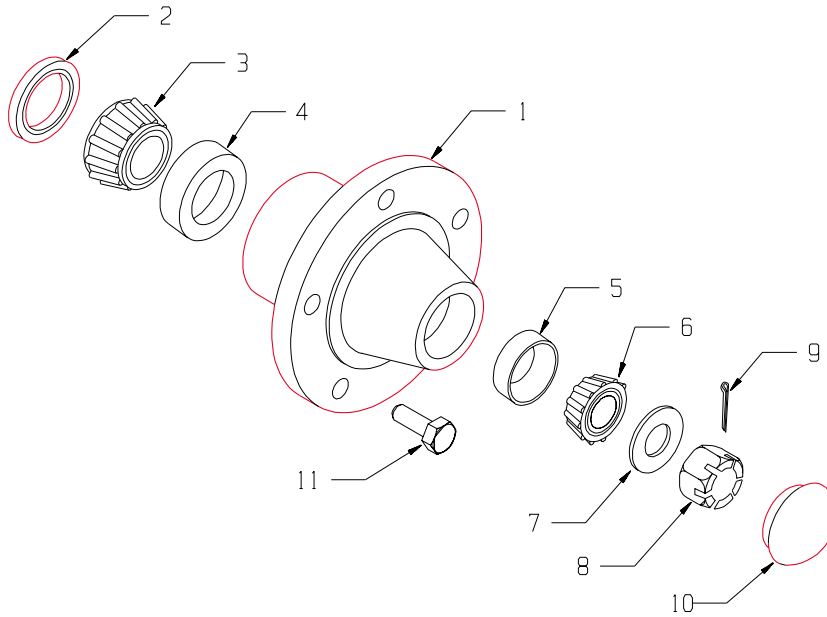

KEY	PART NO.	DESCRIPTION
1	75-0201-1	Hub w/Races
2	75-0201-2	Grease Seal
3	75-0200-3	Inner Wheel Brg
4	75-0200-4	Inner Wheel Race
5	75 -0200-5	Outer Wheel Race
6	75 -0200-6	Outer Wheel Brg
7	75-0200-7	Washer
8	75-0200-8	Nut
9	75-0200-9	Cotter Pin
10	75-0200-10	Cap
11	75-0200-11	Lug Bolt

BUNK FEEDER

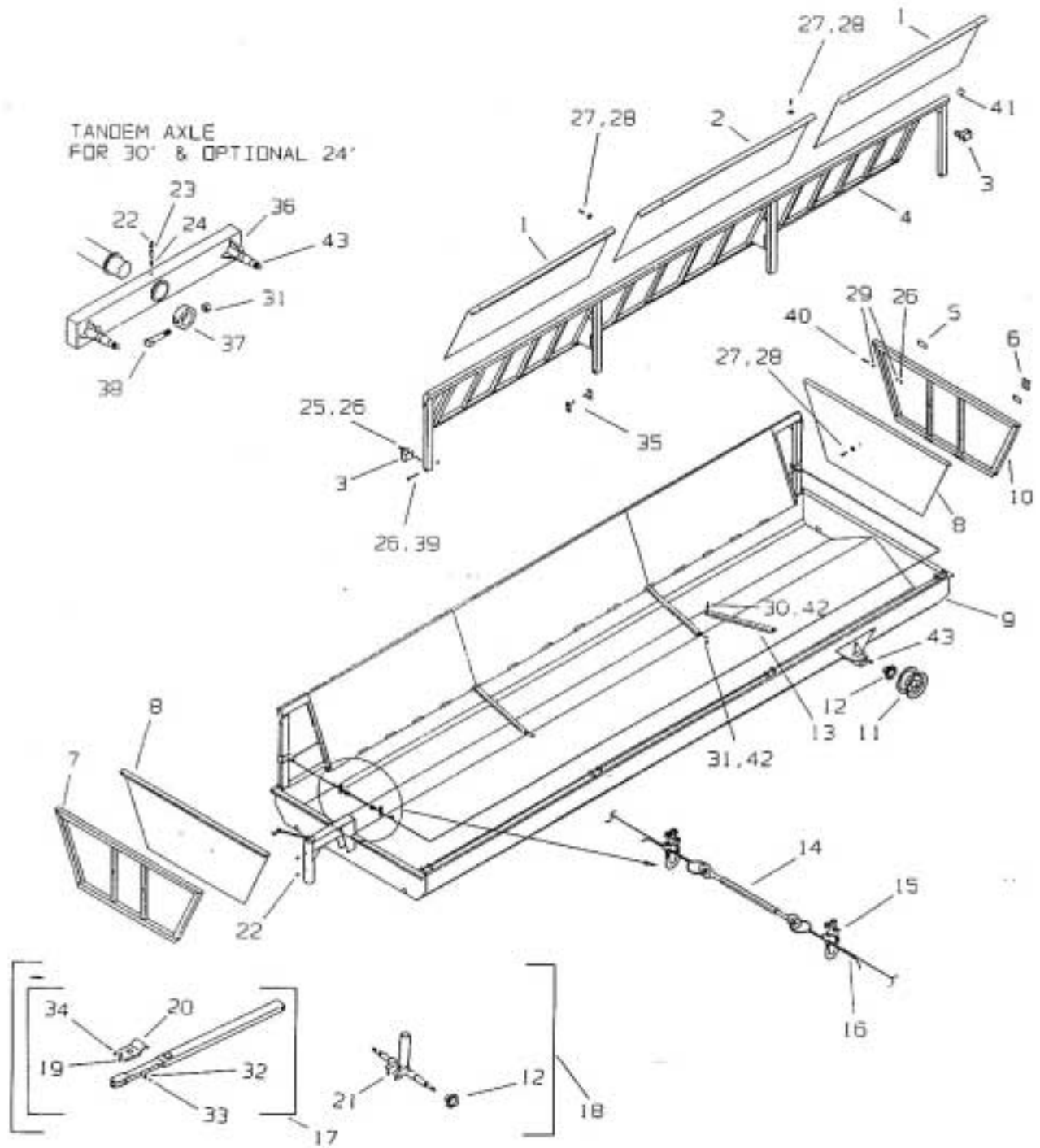

KEY	PART NO.	DESCRIPTION
1,2	200-0130	Galvanized Side Liner 102'
		4 Req'd on 20' Feeder
		4 Req'd on 30' Feeder
	200-0144	Galvanized Side Liner 84-1/4"
		6 Req'd on 24' Feeder
	300-0017	Galvanized Side Liner 118-1/2"
		2 Req'd on 30' Feeder
3	200-0026	Corner Cable Adjust. Brkt.
4	200-0146	20' Side Assembly
	200-0147	24' Side Assembly
	200-0148	30' Side Assembly
5	46-0001-24	Reflector Decal
6	33-1002	Slow Moving Vehicle Bracket
7	200-0 149	Front Panel Assembly
8	200-0129	Galvanized End Liner
9	200-0150	20' Main Pan Assembly
	200-0151	24' Main Pan Assembly
	200.0152	30' Main Pan Assembly
10	200-0153	Back Panel Assembly
11	200-0007	6" Rim
	200-0006	8' Rim
12	75-0201	Hub Assembly
13	200-0126	Center Brace
14	200-0048	Turn Buckle
15	200-0049	Wire Rope Clip 3/8
16	200-0067	Cable 3/8x51',59'.71' (20,24,30' respectively)
17	200-0075	Complete Hitch Assy.
18	200-0064	Complete Steering Assy. w/Hubs & Hitch Assy.
19	29-0004	Spring
20	200-0080	Latch Plate Complete
21	200-0133-1	Steering Assy. With Spindles
22	30-0002	Grease Zerk 1/8 Straight
23	30-0009	Coupler 1/8 NPT
24	30-0008	Nipple 1/8x1-1/2 NPT
25	851-5013-3Z	Machine Bolt 1/2x3
26	814-5013-Z	Nut 1/2 Lock
27	804-0025-Z	Fender Washer 1/4
28	825-25-1Z	Self Drilling Screw 1/4x1

KEY	PART NO.	DESCRIPTION
29	805-0050-Z	Flat Washer 1/2
30	851-3816-1.2 5Z	Machine Bolt 3/8x1-1/4
31	815-3816-Z	Nut 3/8 Lock
32	200-0079	Spacer 3/4IDx1-1/4ODx3/4LG
33	815-7510-Z	Nut 3/4 Lock
34	851-7510-6Z	Machine Bolt 3/4x6
35	200-0097	Center Cable Bracket Assy.
36	300-0002	Tandem Assembly
37	75-0360	Retaining Collar
38	851-3816-4Z	Machine Bolt 3/8x4
39	851-5013-5Z	Machine Bolt 1/2x5
40	851-501 3-2.5Z	Machine Bolt 1 /2x2-1/2
41	200-0121	Rubber End Cap
42	805-0038-Z	Washer 3/8 Flat
43	75-0101	Rear Spindle

