

PB-MIXER-F3



FORMULA MIXER

F3-1460

Owner/Operator's Manual
&
Parts Book

Starting 2022 Model Year



1/24/2025



1.0 IMPORTANT INFORMATION

The mixer serial number plate is located on the front left hand side of the mixing tub.

The trailer serial number plate is located on the left hand side of the trailer hitch.

Please enter the model, serial number and additional information in the space provided for future reference.



**Mixer Body
Serial Number**

Model No. _____

Mixer Serial No. _____

Trailer Serial No. _____

Date of Purchase _____

Dealership _____

Dealership Phone No. _____



**Trailer
Serial Number**

Always use your serial number when requesting information or when ordering parts.

HOW TO READ THE SERIAL NUMBER

MIXER

EXAMPLE: 24VM1460201

Model Year / Vertical Mixer / Model / Sequence Of Build



24



VM



1460



201

TRAILER

EXAMPLE: VMM24201

Vertical Mixer Trailer / Model Year / Sequence Of Build



VMM



24



201

Meyer Manufacturing Corporation
 674 W. Business Cty Rd A
 Dorchester, WI 54425
 Phone: 1-800-325-9103
 Fax: 715-654-5513
 Email: parts@meyermfg.com
 Website: www.meyermfg.com



2.0 PRE-DELIVERY & DELIVERY CHECK LIST

MEYER MANUFACTURING CORPORATION

Phone: 715-654-5132 • Toll-Free: 1-800-325-9103 • P.O. Box 405 • Dorchester, WI 54425

This Pre-Delivery & Delivery Check List must be gone through by the Selling Party and the Customer to validate the Owner's Registration Form.

PRE-DELIVERY CHECK LIST

After the new Meyer Mixer has been completely set-up, check to be certain it is in correct running order before delivering it to the customer.

The following is a list of points to inspect:

Check off each item as you have made the proper adjustments and found the item operating satisfactorily. Any adjustments made, MUST be according to specifications defined in this manual.

- All shields and guards are in place and securely fastened.
- All PTO shields turn freely.
- All bolts and other fasteners are secure and tight.
- All mechanisms operate trouble free.
- All grease fittings have been lubricated, gear boxes filled to proper levels and all roller chains are oiled. Refer to 8.2 LUBRICATION.
- Conveyor Belt or Chain are at proper tension. Refer to 8.3 ADJUSTMENTS.
- All stop/tail/turn lights work properly.
- All decals are in place and legible.

DELIVERY CHECK LIST

The following check list is an important reminder of valuable information that MUST be passed on to the customer at the time the unit is delivered.

Check off each item as you explain it to the customer.

- Explain to the customer that pre-delivery check list was fully completed.
- Give customer the Owner & Operator's Manual. Instruct to read and completely understand its contents BEFORE attempting to operate the mixer.
- Explain and review with customer the new Meyer implement manufacturer's warranty.
- Show the customer where to find the serial number on the implement.
- Explain and review with the customer the 5.1 SAFETY PRECAUTIONS.
- Explain and review with customer the proper "Start-up and Operating Procedures" sections of this manual.
- Demonstrate the PTO Shaft Locking Device and proper PTO shaft storage. Also, demonstrate proper hydraulic hose storage and tip holder used to keep system clean from contaminants.
- Explain that regular lubrication and proper adjustments are required for continued proper operation and long life of the mixer. Review with the customer the 8.2 LUBRICATION and 8.3 ADJUSTMENTS sections of this manual.
- Explain the importance of conveyor chain or belt tension, and the need to watch and tighten during the break-in period.
- Fully complete this PRE-DELIVERY & DELIVERY CHECK LIST with the customer.



3.0 INTRODUCTION

Congratulations on your purchase of a new Meyer farm equipment product. Undoubtedly you have given much consideration to your purchase and we're proud that you have selected Meyer. Pride in craftsmanship, engineering and customer service have made Meyer products the finest in the farm equipment industry today.

There is no substitute for quality. That is why thousands of people like you have purchased Meyer farm equipment. They felt it was the best equipment to serve their farming needs, now and in years to come. We ask that you follow our policy of "safety first", and we strongly suggest that you read through the "Owner / Operator's Manual & Parts Book" before operating your Meyer farm equipment. Meyer Manufacturing Corporation wants to thank you for not compromising quality. We are determined to offer excellence in customer service as well as provide you with the very best value for your dollar.

Sincerely,

All Employees of

MEYER MANUFACTURING CORPORATION

When the PTO is referred to, it means power take-off from the tractor.

The formula mixer may be referred to as mixer, implement, equipment or machine in this manual.



IMPORTANT: You are urged to study this manual and follow the instructions carefully. Your efforts will be repaid in better operation and service as well as a savings in time and repair expense. Failure to read this manual and understand the machine could lead to serious injury. If you do not understand instructions in this manual, contact either your dealer or Meyer Manufacturing Corp. at Dorchester, WI 54425.



WARRANTY: At the front of this manual is an "Owner's Registration Form". Be sure your dealer has completed this form and promptly forwarded a copy to Meyer Manufacturing to validate the manufacturer's warranty. The product model and serial number are recorded on this form and on the inside of the front cover for proper identification of your Meyer implement by your dealer and the manufacturer when ordering repair parts. The mixer serial number plate is located on the front left hand side of the mixing tub. The trailer serial number plate is located on the left hand side of the hitch.



REPAIR PARTS: At the back of this manual is the repair parts section. All replacement parts are to be obtained from or ordered through your Meyer dealership. When ordering repair parts, refer to the parts section and give complete information including quantity, correct part number, detailed description and even model number and serial number of the implements which needs repair parts.

Manufacturer's Statement: Meyer Manufacturing Corporation reserves the right to make improvements in design, or changes in specifications at any time, without incurring any obligation to owners of units previously sold. This supersedes all previous published instructions.



4.0 MANUFACTURER'S WARRANTY

09/2024

MEYER FORMULA MIXER

- I The "Owner's Registration Form" must be completed in full and promptly returned to Meyer Mfg. Corp. for this warranty to become both valid and effective. All warranties on New Meyer Mixers shall apply only to the original retail customer from an authorized Meyer Mfg. Corp. dealership.
- II This warranty shall not apply to any Meyer Mixer which has been subjected to misuse, negligence, alteration, accident, incorrect operating procedures, has been used for an application not designed for or pre-authorized by Meyer in writing, has had the serial numbers altered, or which shall have been repaired with parts other than those obtained through Meyer Mfg. Corp. Meyer is not responsible for the following: Depreciation or damage caused by normal wear, lack of reasonable and proper maintenance, failure to follow the operator's manual recommendations or normal maintenance parts and service. Meyer is not responsible for rental of replacement equipment during warranty repairs, damage to a power unit (including but not limited to a truck or tractor), loss of earnings due to equipment down time, or damage to equipment while in transit to or from the factory or dealer.
- III Meyer Mfg. Corp. warrants New Meyer Mixer to be free from defects in material and workmanship under recommended use and maintenance service, as stated in the operator's and parts manuals, as follows:
 - A. Meyer Mfg. Corp. will repair or replace F.O.B. Dorchester, WI, as Meyer Mfg. Corp. elects, any part of a new Meyer Mixer which is defective in material or workmanship:
 - i Without charge for either parts or labor during the first (1) year from purchase date to the original retail customer.
 - B. In addition to the above basic warranty, Meyer Mfg. Corp. will repair or replace F.O.B. Dorchester, WI as Meyer Mfg. Corp. elects:
 - i Any part of the following which is defective in material or workmanship (not neglect to recommended use and service) with a "pro-rated" charge for parts only (not labor) during the stated time period from date of purchase to the original retail customer. 1st year 100%, 2nd year 100%, 3rd year 50%, 4th year 25%, 5th year 10%
 - a. The Formula Mixer Planetary Gearbox. Meyer Part #'s 119-30-24.3-2.
- IV **COMMERCIAL USE:** Coverage as in paragraph III.A.i. only, except warranty coverage is for (90) days for parts and labor to the original commercial retail customer.
- V Repairs eligible for labor warranty must be made by Meyer Mfg. Corp. or an authorized Meyer dealership. The original retail customer is responsible for any service call and/or transportation of the mixer to the dealership or the factory for warranty service.
- VI Except as stated above, Meyer Mfg. Corp. shall not be liable for injuries or damages of any kind or nature, direct, consequential, or contingent, to persons or property. This warranty does not extend to loss of crop or for any other reasons.
- VII No person is authorized to give any other warranties or to assume any other obligation on Meyer Mfg. Corp.'s behalf unless made or assumed in writing by Meyer Mfg. Corp. This warranty is the sole and exclusive warranty which is applicable in connection with the manufacture and sale of this product and Meyer Mfg. Corp.'s responsibility is limited accordingly.

Purchased Product Warranty:

This warranty does not apply to component parts not manufactured by Meyer such as but not limited to wheels, tires, PTO shafts, clutches, hydraulic cylinders, scales, etc.



TABLE OF CONTENTS

1.0	IMPORTANT INFORMATION	2
2.0	PRE-DELIVERY & DELIVERY CHECK LIST	3
3.0	INTRODUCTION	5
4.0	MANUFACTURER'S WARRANTY	7
5.0	SAFETY	13
5.1	SAFETY PRECAUTIONS	14
5.2	SAFETY SIGNS	16
5.3	SHUTOFF & LOCKOUT POWER	21
5.3.1	SHUTOFF & LOCKOUT POWER RECOMMENDATIONS	21
6.0	PRE-OPERATION	23
6.1	STATIC INSPECTION	23
6.2	LIGHT HOOK-UP	24
6.3	HYDRAULIC HOOK-UP	24
6.4	PTO DRIVELINE OPTION	25
6.5	TRACTOR DRAWBAR SETUP	26
6.6	HITCHING TO TRACTOR	27
6.6.1	JACK STORAGE	27
6.7	START-UP AND SHUT-DOWN	28
6.7.1	START-UP	28
6.7.2	SHUT-DOWN	28
6.8	OPERATIONAL CHECKS	29
6.8.1	CONTROLS	30
6.8.1.1	POWER SHIFT TRANSMISSION	30
6.9	TRANSPORTING	31
6.9.1	SAFETY CHAIN	32
6.9.2	TRACTOR TOWING SIZE REQUIREMENTS	33
6.9.3	BRAKE INFORMATION	33
6.9.4	LOCK-OUT STEERING INSTRUCTION	34
6.10	OPTIONAL EQUIPMENT	34

TABLE OF CONTENTS

7.0	OPERATION	35
7.1	GENERAL	35
7.1.1	MATERIAL.....	36
7.1.2	CUTOUT CLUTCH	36
7.2	LOADING	37
7.2.1	LOADING SEQUENCE	38
7.3	MIXING.....	39
7.3.1	MIXING TROUBLESHOOTING GUIDE	39
7.4	PLATFORM OPERATION.....	40
7.5	UNLOADING	41
7.6	UNHOOKING THE TRACTOR.....	42
7.7	HAY STOP ADJUSTMENT	43
7.7.1	HAY STOP LOCK BOLT	43
8.0	MAINTENANCE	45
8.1	GENERAL	45
8.2	LUBRICATION	45
8.2.1	DAILY LUBRICATION	46
8.2.2	EVERY 8 HOURS.....	47
8.2.3	MONTHLY LUBRICATION	47
8.2.4	EVERY 40 HOURS.....	48
8.2.5	FIRST 50 HOURS	48
8.2.6	EVERY 250 HOURS.....	49
8.2.7	EVERY 500 HOURS.....	49
8.2.8	ANNUALLY OR EVERY 1000 HOURS (WHICHEVER IS FIRST)	50
8.2.9	ANNUALLY OR EVERY 2000 HOURS (WHICHEVER IS FIRST)	50
8.2.10	EVERY 5000 HOURS.....	50
8.2.11	GEARBOX/TRANSMISSION OIL & FILTER CHANGE PROCEDURES	51
8.2.11.1	PLANETARY GEARBOX.....	52
8.2.11.2	POWER SHIFT TRANSMISSION	53
8.3	ADJUSTMENTS.....	54
8.3.1	SIDE DISCHARGE CONVEYOR	55
8.3.2	BELT CONVEYOR TENSION	55
8.3.3	TRACKING	56
8.3.4	FRONT DISCHARGE CONVEYOR - CHAIN	58
8.3.5	AUGER SCRAPER PLATE	58
8.3.6	AUGER TIMING	58
8.3.7	PTO CUTOUT CLUTCH CONNECTION.....	59

TABLE OF CONTENTS

8.3.8	KNIVES	59
8.3.8.1	KNIFE REMOVAL	59
8.3.8.2	ADDING KNIVES	59
8.3.8.3	KNIFE PLACEMENT	59
8.3.8.4	KNIFE POSITION	60
8.3.8.5	REPLACING DAMAGED OR WORN KNIVES	60
8.3.9	BRAKE ADJUSTMENT	60
8.4	FASTENER TORQUE SPECIFICATIONS	61
8.4.1	GENERAL TORQUE SPECIFICATIONS	61
8.4.2	WHEEL TORQUE	63
8.5	ELECTRICAL	63
8.5.1	POWER SHIFT REMOTE CONTROL PROGRAMMING	63
8.5.1.1	REMOTE TROUBLESHOOTING	64
8.5.2	DIGITAL SCALE INDICATOR	64
8.6	BRAKES	65
8.7	WHEELS AND TIRES	66
8.7.1	WHEEL INSTALLATION	66
8.7.2	TIRE INFLATION	66
8.7.3	IMPLEMENT TIRES	67
8.8	STORING THE IMPLEMENT	68
8.9	RETURN THE IMPLEMENT TO SERVICE	68
8.10	MIXER TROUBLESHOOTING GUIDE	69
9.0	REPAIR PARTS	71
	LIGHTS	73
	WEIGH BAR WIRING DIAGRAM	74
	POWER SHIFT ELECTRICAL SYSTEM WITH COOLERS	76
	POWER SHIFT ELECTRICAL SYSTEM WITHOUT COOLERS	76
	POWER SHIFT JUNCTION BOX WITH COOLERS	78
	POWER SHIFT JUNCTION BOX WITHOUT COOLERS	79
	TRAILER	80
	PTO SHROUD	82
	RIGID AXLE	84
	STEERABLE AXLE	86
	LEAF SPRING	88
	LOCK & STEER HYDRAULIC SYSTEM	90
	HYDRAULIC BRAKE SYSTEM	92
	MIXER	94
	FRONT FLAT & INCLINE BASE BELT CONVEYOR	96
	FRONT FLAT & INCLINE BASE BELT CONVEYOR (CONT'D)	98

TABLE OF CONTENTS

FRONT FLAT BELT CONVEYOR HYDRAULIC SCHEMATIC	100
FRONT FLAT CHAIN CONVEYOR ASSEMBLY	102
FLAT CHAIN CONVEYOR HYDRAULIC SCHEMATIC	104
DOOR	106
FRONT & REAR DOOR HYDRAULIC SCHEMATIC	108
QUAD DOOR HYDRAULIC SCHEMATIC.....	109
VIEWING PLATFORM.....	110
AUGER	112
POWER SHIFT DRIVELINE	114
POWER SHIFT TRANSMISSION (EXTERNALS).....	116
POWER SHIFT TRANSMISSION (INTERNALS).....	118
POWER SHIFT TRANSMISSION OIL COOLING SYSTEM	120
3003 SERIES PLANETARY	122
PLANETARY GEARBOX OIL SYSTEM	124
PLANETARY GREASE COMPONENTS.....	126
PRIMARY PTO DRIVE SHAFT	128
PRIMARY PTO DRIVE SHAFT (OPTIONAL).....	130
FRONT DISCHARGE SECONDARY PTO DRIVE SHAFT	132
SIDE/QUAD DISCHARGE SECONDARY PTO DRIVE SHAFT.....	134
INTERMEDIATE PTO DRIVE SHAFT	136
FRONT DOOR CUTOUT CLUTCH	138
SIDE/QUAD DOOR CUTOUT CLUTCH.....	139
10.0 OPTIONAL PARTS	141
CAPACITY EXTENSION	142
SIDE DOOR HANGING WEIGHT ASSEMBLY	143
REMOTE SCALE MOUNT	144
RUBBER SIDE DOOR CHUTE ASSEMBLY	146
CONVEYOR HANGING MAGNET & WEIGHT ASSEMBLY	148
CONVEYOR DEFLECTOR ASSEMBLY	148
POWER MAGNET	150
FRONT PLANETARY OIL COOLING SYSTEM.....	152
MIDDLE PLANETARY OIL COOLING SYSTEM.....	154
REAR PLANETARY OIL COOLING SYSTEM	156
QUAD DOOR INDEPENDENT DOOR CONTROLS	158
11.0 SPECIFICATIONS.....	159
NOTES	162
12.0 MAINTENANCE RECORDS	163

5.0 SAFETY

The Meyer implement is manufactured with operator safety in mind. Located on the implement are various safety signs to aid in operation and warn of danger or caution areas. Pay close attention to all safety signs on the implement.

Carefully follow the operating and maintenance instructions in this manual and all applicable safety laws. Failure to follow all safety procedures may result in serious injury or death.

Before attempting to operate this implement, read and study the following safety information. In addition, make sure that every individual who operates or works with the implement, whether family member or employee, is familiar with these safety precautions.

Meyer Mfg. Corp. provides guards for exposed moving parts for the operator's protection; however, some areas cannot be guarded or shielded in order to assure proper operation. The operator's manual and safety signs on the implement itself warn you of dangers and must be read and observed closely!



Safety Alert Symbol

This symbol is used to call attention to instructions concerning personal safety. Be sure to observe and follow these instructions. Take time to be careful!



DANGER

The signal word **DANGER** on the machine and in the manual identifies a hazardous situation which, if not avoided, WILL result in death or serious injury.



WARNING

The signal word **WARNING** on the machine and in the manual indicates a potentially hazardous situation which, if not avoided, COULD result in serious injury or death.



CAUTION

The signal word **CAUTION** on the machine and in the manual indicates a potentially hazardous situation which, if not avoided, MAY result in minor or moderate injury. It may also be used to alert against unsafe practices.

IMPORTANT

This notice identifies procedures which must be followed to avoid damage to the machine.

Danger, Warning, Caution, and instructional decals and plates are placed on the equipment to protect anyone working on or around this machine, as well as the components of the machine. All personnel operating or maintaining this equipment must familiarize themselves with all Danger, Warning, Caution, and instructional decals and plates.

5.1 SAFETY PRECAUTIONS

 **CAUTION**



All individuals who will operate this implement must read and completely understand this Owner / Operator's and Parts Manual. Operator must receive instructions before operating the machine. Untrained operators can cause injury or death.

- DO NOT allow anyone to operate, service, inspect or otherwise handle this equipment until all operators have read and understood all of the instructional materials in this Operator's And Parts Manual and have been properly trained in its intended usage.
- For an operator to be qualified, he or she must not use drugs or alcohol which impair alertness or coordination while working. An operator who is taking prescription drugs must get medical advice to determine if he or she can safely operate a machine and the equipment.
- Make sure all personnel can READ and UNDERSTAND all safety signs.
- DO NOT allow minors (children) or inexperienced persons to operate this equipment.
- DO NOT operate until all shields and guards are in place and securely fastened.
- DO NOT step up on any part of the equipment that is not designated as a ladder or viewing platform at any time.
- DO NOT adjust, clean or lubricate while the equipment is in motion.
- Inspect when first delivered and regularly thereafter; that all connections and bolts are tight and secure before operating.
- Know how to stop operation of the equipment before starting it!
- Make certain everyone is clear of the equipment before applying power.
- Keep hands, feet and clothing away from moving parts. Loose or floppy clothing should not be worn by the operator.
- Observe all applicable traffic laws when transporting on public roadways (where legal to do so). Check local laws for all highway lighting and marking requirements.
- Shut off and lock out power before adjusting, servicing, maintaining or clearing an obstruction from this machine. Refer to 5.3 SHUTOFF & LOCKOUT POWER.
- Always enter curves or drive up or down hills at a low speed and at a gradual steering angle.
- Never allow riders on either tractor / truck or equipment.
- Keep tractor / truck in a lower gear at all times when traveling down steep grades.
- Stay away from overhead power lines. Electrocution can occur without direct contact.
- Use only properly rated undercarriage and tires.

Safety Precautions For Tractor Towed Units:

- Do not exceed 20 mph (32 kph). Reduce speed on rough roads and surfaces.
- Always install a SMV emblem on pull-type equipment when transporting on roadways and keep clean and bright.
- Always yield to oncoming traffic in all situations and move to the side of the road so any following traffic may pass.
- Comply with state and local laws governing highway safety and movement of machinery on roadways.

Safety Precautions For Hydraulic System:

- Check hydraulic tubes, hoses and fittings for damage and leakage. Never use hands to check for leaks. Hydraulic tubes and hoses must be properly routed and have adequate support and secure clamps. Tighten or replace any parts that show leakage.
- Always clean fluid spills. Do not use gasoline or diesel fuel for cleaning parts. Use commercial nonflammable solvents.

5.2 SAFETY SIGNS



Read all safety signs on the implement and in this manual. Keep all safety signs clean and replace any damaged or missing safety signs before operating the equipment. Do not remove any safety signs. Safety signs are for operator protection and information.

FRONT OF IMPLEMENT

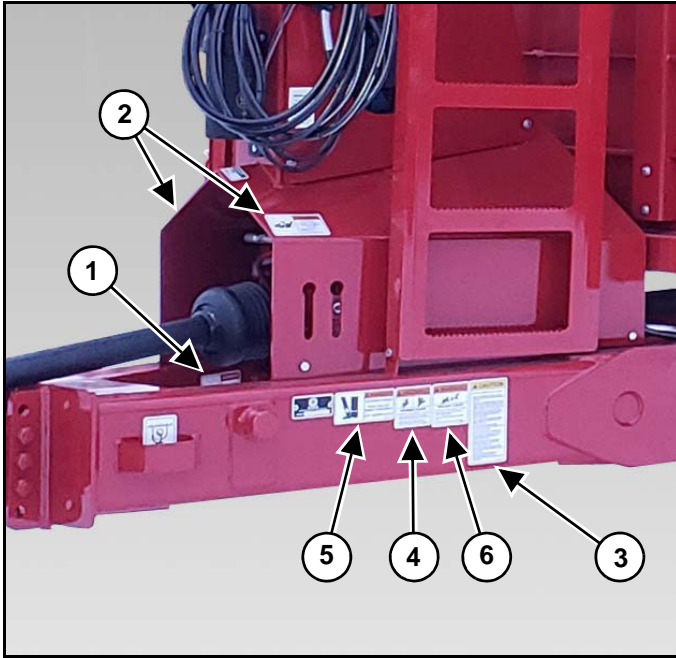

1



PART NO. 46-3600-2

(Located On Trailer Frame Underneath Housing)

2

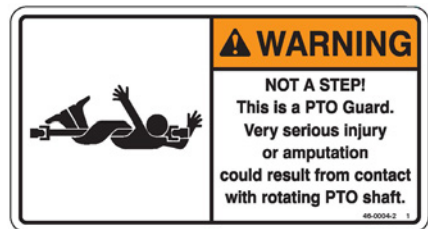

PART NO. 46-0004-2

3

4

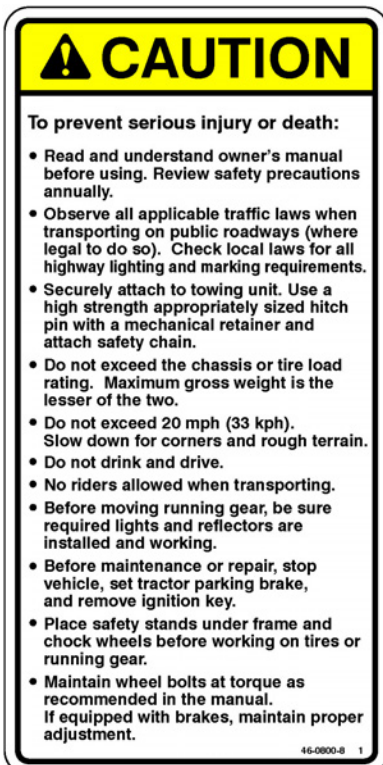

PART NO. 46-0800-8



PART NO. 46-0800-6

6



PART NO. 46-0800-7

5



PART NO. 46-3600-6

FRONT OF IMPLEMENT

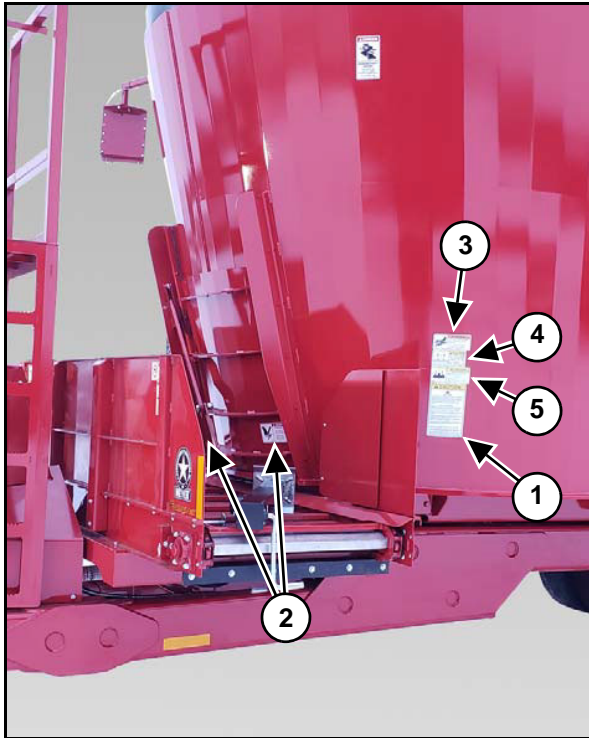

1

⚠ CAUTION

⚠ SAFETY FIRST

Do Not Operate This Machine Without Reading These Instructions!

Meyer Manufacturing Corporation provides guards for exposed moving parts for the operator's protection; however, some areas cannot be guarded or shielded in order to ensure proper operation. The operator's manual and safety signs on the equipment itself warn you of hazards and must be read and observed closely!

The safety alert symbol ⚠ is used to call attention to instructions concerning personal safety. Be sure to observe and follow these instructions. Take time to be careful!

⚠ SAFETY PRECAUTIONS

DO NOT allow anyone to operate, service, inspect or otherwise handle this equipment until all operators have read and understood all of the instructional materials in the operator's and parts manual and have been properly trained in its intended usage.

DO NOT operate until all shields and guards are in place and securely fastened.

DO NOT step up on any part of the equipment that is not designated as a seat, ladder, or viewing platform at any time. Never allow riders on either tractor / truck or equipment.

Ensure the machine is and will remain in the OFF condition before adjusting, servicing, maintaining, or clearing an obstruction from this machine.

PTO OPTIONS: The tractor PTO **MUST** match the implement PTO. **NEVER USE PTO ADAPTERS.** PTO shield **MUST** be in place and rotate freely. Always run PTO in a straight line to avoid an accident due to PTO damage.

Know how to stop operation of the equipment before starting it! Make certain everyone is clear of the equipment before applying power. Make certain everyone stays clear of the discharge opening while operating.

Keep hands, feet, and clothing away from moving parts. Loose or floppy clothing should not be worn by the operator.

Observe all applicable traffic laws when transporting on public roadways (where legal to do so). Check local laws for all highway lighting and marking requirements.

Keep all safety signs clean and replace any damaged or missing safety signs before operating the equipment. **DO NOT** remove any safety signs. If any safety signs become damaged or lost, call your local Meyer dealer or Meyer factory direct 1-800-325-9103 for replacement. Always use **GENUINE MEYER** replacement parts.

46-0001-22 1

PART NO. 46-0001-22

2

46-0001-208 1

⚠ DANGER

MOVING BLADE!

KEEP HANDS AND ARMS CLEAR WHILE MACHINE IS OPERATING

DISCONNECT AND LOCK OUT POWER BEFORE ENTERING MIXER

PART NO. 46-0001-208

3

46-8500-7 1

⚠ WARNING

OIL INJECTION HAZARD

RELIEVE PRESSURE BEFORE SERVICING.

DO NOT CHECK WITH HANDS.

IF INJURED SEEK EMERGENCY MEDICAL ATTENTION.

PART NO. 46-8500-7

4

46-0001-62 1

⚠ CAUTION

Use Flashing Warning Lights when transporting on ALL highways (public roadways) at ALL times.

EXCEPT WHEN PROHIBITED BY LAW!
(Check w/local law enforcement)

By all State and Federal laws, implement lights do not replace the SMV (Slow-Moving Vehicle) Identification Emblem. All towed agricultural vehicles must display SMV Emblems when traveling LESS than 20 mph (32 kph).

PART NO. 46-0001-62

5

46-0001-35 1

⚠ CAUTION

TO PREVENT SERIOUS INJURY OR DEATH

- DO NOT start, operate, or work on this machine without first carefully reading and thoroughly understanding the entire contents of the operators manual. (Require the same of all personnel who will operate this machine.)
- If operators manual is lost, contact your nearest Meyer Dealership or write or call: MEYER MFG., CORP. P.O. BOX 405 • Dorchester, WI 54425-0405 Phone 1-800-325-9103

Please give your name, address, phone number, model and serial number of your machine. A manual will be furnished.

- If you have any questions about operation or adjustments, and maintenance of this machine, contact your Meyer Dealership or Meyer Mfg., Corp. before starting or continuing the operation of this machine.

PART NO. 46-0001-35

FRONT OF IMPLEMENT

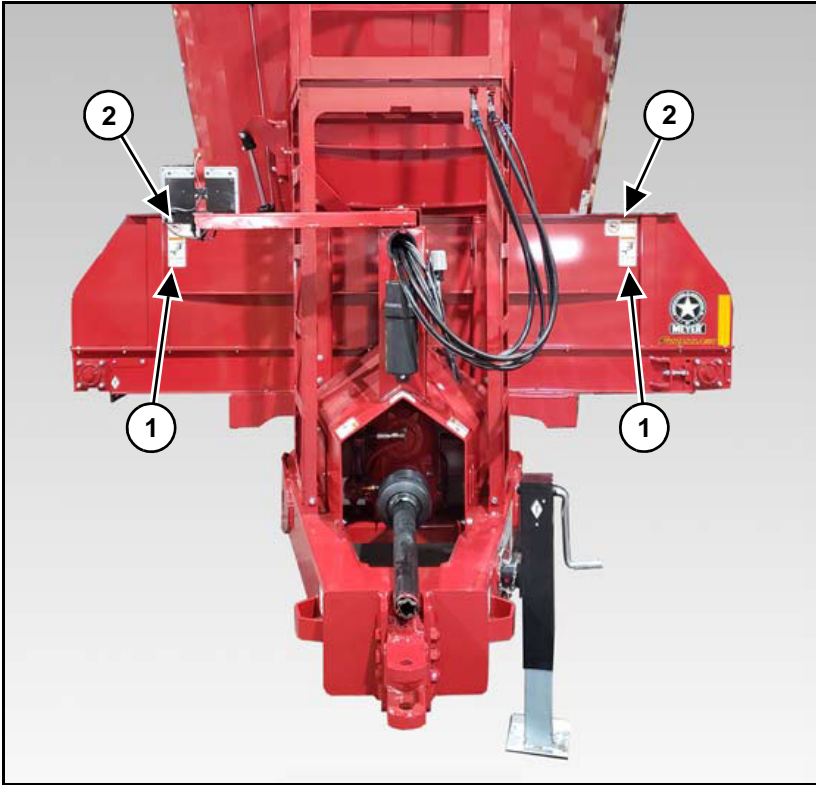

PART NO. 46-0001-210



PART NO. 46-8500-7



PART NO. 46-0001-209

RIGHT SIDE OF IMPLEMENT

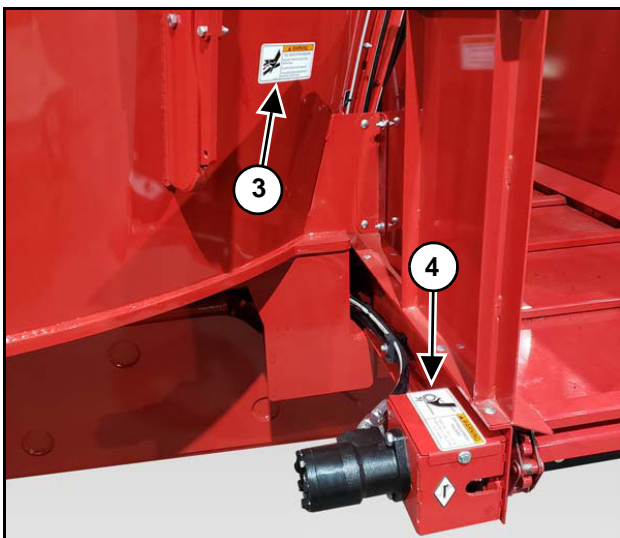

PART NO. 46-0001-4



PART NO. 46-0001-207
(Located Under Shield - Not Shown)

RIGHT SIDE OF IMPLEMENT



PART NO. 46-0001-211
(Located Under Mixing Tub)



PART NO. 46-0001-213

LEFT SIDE OF IMPLEMENT

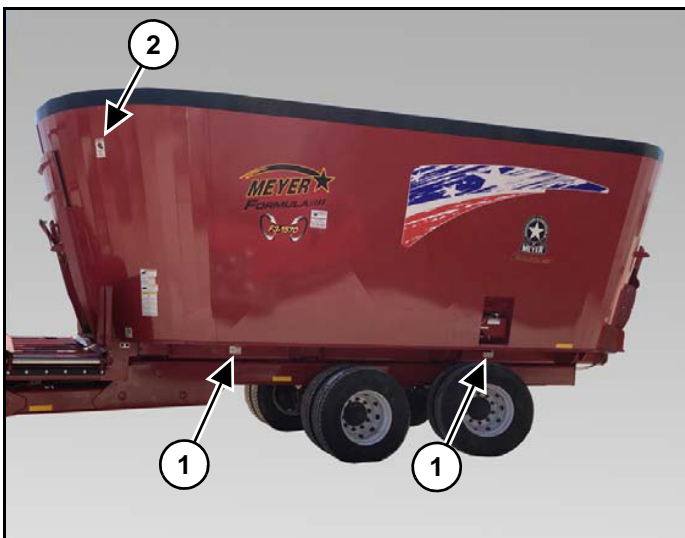

BACK OF IMPLEMENT

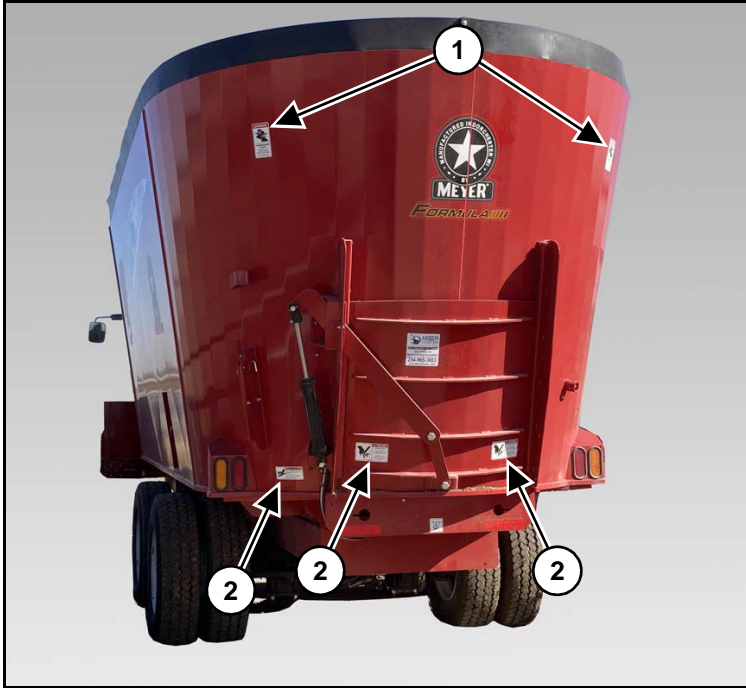

PART NO. 46-0001-213

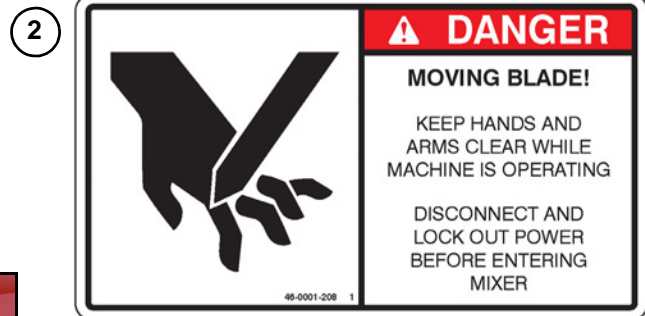

PART NO. 46-0001-208

SIDE/QUAD DOOR



PART NO. 46-8500-7

5.3 SHUTOFF & LOCKOUT POWER



Any individual that will be adjusting, servicing, maintaining, or clearing an obstruction from this machine needs to ensure that this machine stays safely OFF until the adjustment, service, or maintenance has been completed, or when the obstruction has been cleared, and that all guards, shields, and covers have been restored to their original position. The safety of all individuals working on or around this machine, including family members, are affected. The following procedure will be referred to throughout this manual, so be familiar with the following steps.

5.3.1 Shutoff & Lockout Power Recommendations

1. **Think, Plan and Check**
 - a. **THINK** through the entire procedure and identify all the steps that are required.
 - b. **PLAN** what personnel will be involved, what needs to be shut down, what guards/shields need to be removed, and how the equipment will be restarted.
 - c. **CHECK** the machine over to verify all power sources and stored energy have been identified including engines, hydraulic and pneumatic systems, springs and accumulators, and suspended loads.
2. **Communicate** - Let everyone involved, including those working on or around this machine, that work is being done which involves keeping this machine safely “OFF”.
3. **Power Sources**
 - a. **LOCKOUT** - Shut off engines and take the key, or physically lock the start/on switch or control. Disconnect any power sources which are meant to be disconnected (i.e. electrical, hydraulic, and PTO of pull-type units).
 - b. **TAGOUT** - Place a tag on the machine noting the reason for the power source being tagged out and what work is being done. This is particularly important if the power source is not within your sight and/or will need to be isolated for a longer period of time.
4. **Stored Energy** - Neutralize all stored energy from its power source. Ensure that this machine is level, set the parking brake, and chock the wheels. Disconnect electricity, block movable parts, release or block spring energy, release pressure from hydraulic and pneumatic lines, and lower suspended parts to a resting position.
5. **Test** - Do a complete test and personally double check all of the above steps to verify that all of the power sources are actually disconnected and locked out.
6. **Restore Power** - When the work has been completed, follow the same basic procedures, ensuring that all individuals working on or around this machine are safely clear of the machine before locks and tags are removed and power is restored.

IMPORTANT

It is important that everyone who works on this equipment is properly trained to help ensure that they are familiar with this procedure and that they follow the steps outlined above. This manual will remind you when to SHUTOFF & LOCKOUT POWER.



6.0 PRE-OPERATION



Always keep all shields and guards in place and securely fastened. Keep hands, feet and clothing away from moving components.



DO NOT allow anyone to operate, service, inspect or otherwise handle this implement until all operators have read and understand all of the instructional materials in this Owner / Operator's and Parts Manual and have been properly trained in its intended usage.

Verify that the implement is securely hitched to the tractor/truck.

Verify that all electrical/hydraulic connections and bolts/hardware are tight and securely fastened before operating the implement.

Wear safety glasses to prevent eye injury when any of the following conditions exist:

- When fluids are under pressure.
- Flying debris or loose material is present.
- Tools are being used.

6.1 STATIC INSPECTION



Hydraulic fluid escaping under pressure can have sufficient force to cause injury. Keep all hoses and connections in good serviceable condition.

Before operating the mixer for the first time and each time thereafter, check the following items:

1. Check that all safety signs are in good and legible condition.
2. Inspect the mixer for proper adjustments. Refer to Section 8.3 ADJUSTMENTS.
3. Check that all lubrication has been completed. Refer to Section 8.2 LUBRICATION.
4. Make sure that all guards and shields are in place, secured and functioning as designed.
5. Check condition of all hydraulic components for leaks and electrical cords and cables for wear. Repair or replace as required.
6. Check that all planetary and transmission radiators are clean and clear of any debris. Clean radiators with compressed air if necessary.
7. Check the planetary gearbox reservoir for proper oil level. Check power shift transmission sight glass for proper oil level. Refer to Section 8.2 LUBRICATION.
8. Check for and remove any foreign objects in the mixing chamber and discharge opening.
9. Be sure that there are no tools laying on or in the mixer.
10. Verify that all electrical and hydraulic connections are tight and secure before operating.
11. Check that all hardware is in place and is tight.
12. Watch for any worn or cracked welds. If found, have qualified personnel repair immediately or replacement is necessary.
13. Check all bearings. Replace as needed.
14. Inspect any wear items. i.e.: Knives, scrapers, kicker wear plate. Replace as required.
15. Inspect the tires for excessive wear or damage and inflate to the recommended pressure. Refer to Section 8.7 WHEELS AND TIRES.
16. Inspect the condition of axles and safety lighting. Repair or replace as required.
17. Check that the brakes are clean and clean them if necessary. Refer to Section 8.6 BRAKES.

6.2 LIGHT HOOK-UP

Note: *The lighting system provided is intended for being transported by an agricultural tractor.*

Ensure that lights and indicators are clean and in good working order. When attaching to a towing vehicle other than a tractor always check lighting for proper operation as wiring may vary. Connect to the standardized 7-pin socket located at the back of the tractor.

Color	Function	SAE Terminal	SAE Connector
White	Ground	1	 <p>Viewed From Back</p>
White	J-Box Ground	1	
	Not Used	2	
Yellow	Left Turn & Hazard	3	
	Not Used	4	
Green	Right Turn & Hazard	5	
Brown	Tail Lights	6	
Black	J-Box	7	

Note: *The brake wire should only be connected to the #4 terminal if the #4 terminal on the tractor is confirmed to be a brake light terminal. If the tractor does not have a brake light terminal, cap / seal off the end of the brake wire of the implement (secure to other wires).*

6.3 HYDRAULIC HOOK-UP



WARNING

Hydraulic fluid escaping under pressure can have sufficient force to cause injury. Keep all hoses and connections in good serviceable condition.

Whenever working on any part of the hydraulics, safely relieve hydraulic pressure before starting.

IMPORTANT

Do not exceed maximum PSI or a motor failure could result.

Pull Type: Requires 25 GPM @ 3000 PSI.

Call the factory if additional information is needed.

Note: *The PTO horsepower and/or hydraulic requirements may not reflect adequate tractor size for towing the machine.*

6.4 PTO DRIVELINE OPTION



Do not operate without PTO guard on implement and tractor. Maintain PTO drive shaft guard in good operating condition. Replace them if damaged and not turning freely.



Shutoff and lockout power before adjusting, servicing, maintaining, or clearing an obstruction from this machine. Refer to section 5.3 SHUTOFF & LOCKOUT POWER.

The tractor half of the PTO drive shaft assembly must be locked securely to the tractor output shaft and the implement half of the PTO drive shaft assembly must be locked securely to the implement driveline.

See the PTO Installation, Service, and Safety Instruction Manual for additional PTO details. For a replacement manual, call the factory at 1-800-325-9103.

See the ADMA Safety Manual for further safety situations and precautions, ensure all operators become familiar with it. For a replacement manual, call the factory at 1-800-325-9103.

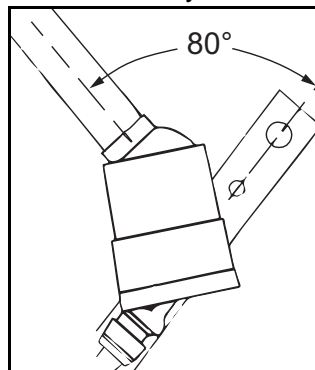

IMPORTANT

Do not exceed the maximum 80° turning angle on the constant velocity PTO driveline. Exceeding the turning angle will damage the constant velocity “center housing” and exerts excessive pressures on the PTO input center shaft and related bearings.

6.5 TRACTOR DRAWBAR SETUP

Do not operate 1000 RPM implements at 540 RPM. No PTO adapter should be used to alter speed or geometry.

Set the tractor drawbar to conform to the standard dimensions as shown. An improperly located hitch point may cause damage to the universal joints of the PTO drive shaft. This will ensure that the PTO drive shaft will not be over extended.

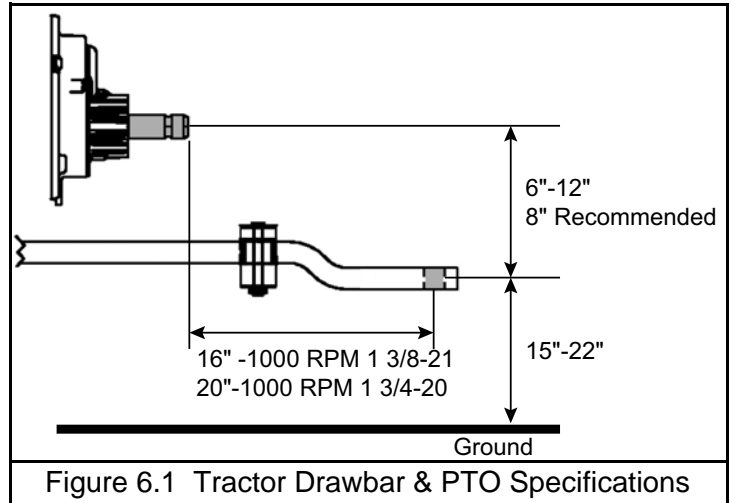

An improperly positioned hitch point may cause damage to the universal joints of the PTO drive shaft. Conforming to the standard 16" or 20" drawbar & PTO relationship will ensure that the PTO drive shaft will not become over-extended.

With initial hook-up to your implement test PTO travel by turning equipment in both directions observing the minimum (A) and maximum (B) travel dimensions.

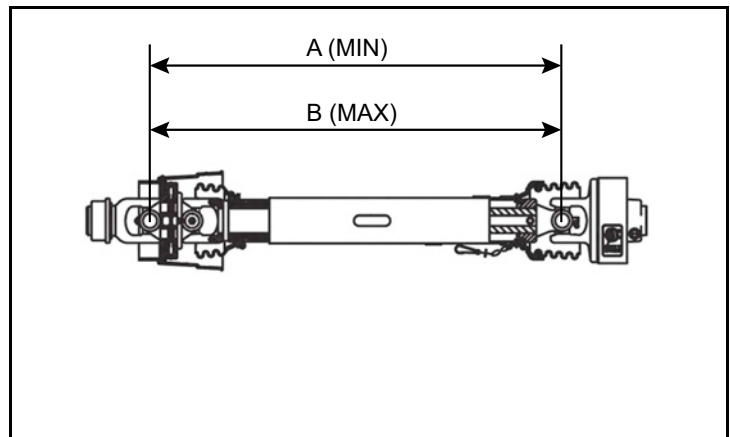

PTO PART NUMBER	A	B
118-VM-0024-55	38.19"	50.98"
118-VM-0001-2600	37.80"	49.45"

6.6 HITCHING TO TRACTOR



WARNING

Do not allow anyone to stand between the tongue or hitch and the tractor when backing up to the implement.

Before hitching to the tractor, make sure that there is sufficient ballast on the front axle of the tractor.

Depending on conditions, the ballast weight needs to be adjusted to optimize tractor drive. The front axle load must never, under any circumstances, be less than 20% of the tractor's unladen weight.

Move to the operator's position, start the engine and release the parking brake.

Move the tractor in front of the mixer. Slowly move the tractor backwards towards the mixer and align the drawbar with the implement's hitch.

Note: Lower or raise the mixer jack to properly align the drawbar and hitch.

Fasten the forage box hitch to the tractor drawbar with a properly sized hitch pin with safety retainer. (Reference ANSI/ASABE AD6489-3 Agricultural vehicles - Mechanical connections between towed and towing vehicles - Part 3: Tractor drawbar.) (See your Trailer / Chassis manual for further details.)

Before operation and after hitching the tractor to the implement, connect the hydraulic hoses and light cord to the tractor. Connect any optional equipment as needed.

6.6.1 Jack Storage

After hitching the mixer or the tractor.

Using the handle, raise the jack off the ground and remove the pin. Move the jack to the storage mount (Item 1) located on the back right hand side of the mixing tub. Reinstall the pin to lock the jack into the transport position.

Note: Keeping jack stored in proper position will keep it from getting damaged during transportation.



Figure 6.2 Jack Storage

6.7 START-UP AND SHUT-DOWN



WARNING

Disengage electric/ hydraulic power, engage the machine's parking brake, stop the engine and make sure all moving components are completely stopped before connecting, disconnecting, adjusting or cleaning this equipment.

Always keep all shields and guards in place and securely fastened.

Keep hands, feet and clothing away from moving components.



CAUTION

Shutoff and lockout power before adjusting, servicing, maintaining, or clearing an obstruction from this machine. Refer to section 5.3 SHUTOFF & LOCKOUT POWER.

DO NOT allow anyone to operate, service, inspect or otherwise handle this implement until all operators have read and understand all of the instructional materials in this Owner / Operator's and Parts Manual and have been properly trained in its intended usage.

Before operating the implement, look in all directions to ensure there are no bystanders, especially small children, in the work area.

6.7.1 Start-Up

1. Be sure there is no one inside the mixer and the mixer is empty.
2. Enter the tractor and start the engine.
3. Set the parking brake.
4. Check to see that the discharge door is closed.
5. Slowly engage the PTO and operate at idle speed.
6. Bring PTO RPM up to its rated RPM.

6.7.2 Shut-Down

1. Disengage the PTO.
2. Turn off conveyor, if equipped.
3. Fully lower all doors.
4. Raise slide trays or conveyors, if equipped.
5. Park the mixer on a flat, level surface.
6. Engage the parking brake, stop the engine and exit the tractor.

6.8 OPERATIONAL CHECKS



Always keep all shields and guards in place and securely fastened. Keep hands, feet and clothing away from moving components.



Shutoff and lockout power before adjusting, servicing, maintaining, or clearing an obstruction from this machine. Refer to section 5.3 SHUTOFF & LOCKOUT POWER.

DO NOT allow anyone to operate, service, inspect or otherwise handle this implement until all operators have read and understand all of the instructional materials in this Owner / Operator's and Parts Manual and have been properly trained in its intended usage.

Before operating the implement, look in all directions to ensure there are no bystanders, especially small children, in the work area.



If cooling power fault light is flashing, overheating of gearboxes will occur. Refer to section 8.10 MIXER TROUBLESHOOTING GUIDE.

Before running material through the mixer for the first time and each time thereafter, follow these steps:

1. Follow the Start-Up procedure section 6.7.1 Start-Up.
2. Raise and lower the door several times.
3. Lower and raise mixer slide trays or conveyors, if equipped.
4. Operate the mixer augers and conveyors, if equipped, for approximately 5-10 minutes. Shift the power shift transmission into high for the last minute of test run time.
5. Follow the Shut-Down procedure section 6.7.2 Shut-Down.
6. Check drive components to be sure components are not abnormally hot.
7. Check all hydraulic components for leaks.
8. Adjust and lubricate equipment as needed. See Section 8.3 ADJUSTMENTS and Section 8.2 LUBRICATION.

6.8.1 Controls

6.8.1.1 Power Shift Transmission

A remote control is provided with the mixer. There are 2 switches, one to shift to “Low” (Key 1) and one to shift to “High” (Key 2). The power shift transmission will only shift to “High”, once selected, if the PTO RPM is at 650RPM. The “High” speed light (Key 3) will light up indicating the power shift transmission is in “High” speed.



Figure 6.3 Remote



Figure 6.4 “High” Speed Indicator Light

6.9 TRANSPORTING

CAUTION

- DO NOT allow anyone to operate, service, inspect or otherwise handle this implement until all operators have read and understand all of the instructional materials in this Owner/ Operator's and Parts Manual and have been properly trained in its intended usage.
 - Before operating the implement, look in all directions to ensure there are no bystanders, especially small children, in the work area.
 - No riders allowed when transporting.
 - Do not drink and drive.
 - Before moving, be sure required lights and reflectors are installed and working.
 - Before maintenance or repair, stop vehicle, set parking brake, and remove ignition key.
 - Place safety stands under frame and chock wheels before working on tires or chassis.
 - Maintain wheel bolts at torque as recommended in the manual.
 - If equipped with brakes, maintain proper adjustment.
-

CAUTION

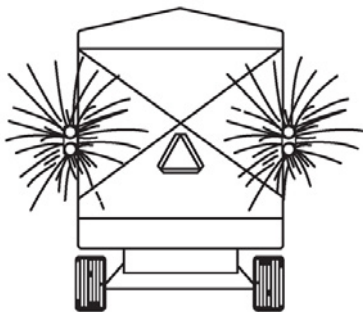

PULL-TYPE UNITS

- Use flashing warning lights when transporting on ALL highways (public roadways) at ALL times (Tractor towed models) EXCEPT WHEN PROHIBITED BY LAW! (Check w/local law enforcement).
 - Adhere to all state and federal laws. Implement lights do not replace the SMV (Slow-Moving Vehicle) identification emblem. All towed agricultural vehicles must display SMV emblems when traveling LESS than 20 mph (32 kph).
 - Check for traffic constantly. Be sure you can see that no one is attempting to pass you and that all traffic is sufficiently clear from you before making any turns.
 - Securely attach to towing unit. Use a high strength appropriately sized hitch pin with mechanical retainer and attach safety chain.
 - Do not exceed 20 mph (32 kph). Slow down for corners and rough terrain.
-

WARNING



- Shift to lower gear before going down steep grades
 - Avoid traveling on slopes or hills that are unsafe
 - Keep towing vehicle in gear at all times
 - Never exceed a safe travel speed (may be less than 20 MPH)
-

WARNING

You must observe all applicable traffic laws when transporting on public roadways. Check local laws for all highway lighting and marking requirements.

(Tractor Powered) Do not tow at speeds in excess of 20 mph.

IMPORTANT

Verify that the rear discharge door is in the closed position before traveling on roadways.

If you will travel on public roads and it is legal to do so, you must know all rules governing such operation. This will include lighting and brake requirements in addition to traffic rules.

6.9.1 Safety Chain

The chain must be of adequate size to hold the weight of the loaded implement.

Note: *If using a grab hook at the end(s) of the chain to secure the chain to itself, a hook latch (Item 1) must be installed.*

The length of the safety chain is not to be any longer than necessary to turn without interference. If any chain links or attachment hardware are broken or stretched, repair before using. Store chain so it does not corrode or become damaged. Do not use this chain for other implements because the strength and length of the chain may not be adequate. Identify this chain for use on this particular implement.

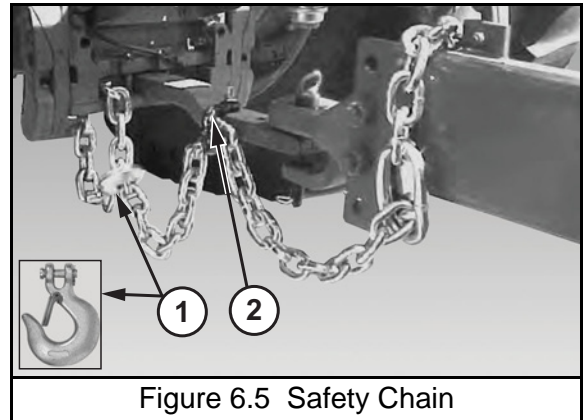

Figure 6.5 Safety Chain

Note: *Do not use the intermediate support (Item 2) as the attaching point.*

IMPORTANT

If you do not have a safety chain, or a replacement safety chain is needed, see your local Meyer dealer and do not operate on public roads until you are able to travel with the safety chain properly installed.

6.9.2 Tractor Towing Size Requirements

Use the following charts to help calculate the minimum tractor weight when towing without implement brakes. The minimum tractor weight, up to 20 mph (33 kph) needs to be two thirds of the box Gross Weight (GW). Gross Weight is calculated by the empty weight of the box and undercarriage combined added to the Load Weight. Then take the Gross Weight and multiply it by 0.667 and you will get the Minimum Required Weight of the Tractor. A tractor with this recommended weight for your machine is normally adequate for towing the loaded machine under average conditions.

Note: *Implement Loaded Weight x 0.667 = Minimum Tractor Weight Up to 20 mph*

Model	MAXIMUM IMPLEMENT GROSS WEIGHT (LBS)	MINIMUM TRACTOR WEIGHT UP TO 20 MPH (LBS)

6.9.3 Brake Information

Two brake systems are offered for your implement. A brake system is recommended for any implement operated on public roads and may be a requirement.

6.9.3.1 Lever Operated Hydraulic Brakes

IMPORTANT When brakes are not required, the selector control valve lever must be in the “float” position.

This brake system is connected to the tractor remote hydraulic ports and is controlled by the tractor hydraulic system. The two hose system has a hydraulic manifold with pressure relief to prevent excessive pressure to the brake activating cylinders.

Applying hydraulic pressure from the tractor causes tractor hydraulic fluid to flow under pressure to the pressure relief valve which extends the brake cylinders to activate the brakes.

Applying The Brakes - Gradually move the tractor SCV (Selector Control Valve) lever as required to apply the brakes. The hydraulic hoses should be connected to the tractor ports so the SCV lever gives the expected response. Test this after hooking up. If response is opposite of expected, reverse the hoses.

Releasing The Brakes - Move the tractor SCV lever to the opposite direction and hold momentarily. Then return lever to the “Float” position.

Note: *Simply returning the SCV lever to the neutral position without first moving the lever to the opposite position, will not release the brakes.*

6.9.3.2 Pedal Operated Hydraulic Brakes

CAUTION At no time should the brake system be used as a parking brake. With loss of hydraulic pressure, the brakes will lose their holding power.

This brake system is a one hose system. The single hydraulic hose must be connected to the tractor remote pedal port.

Applying The Brakes - Gradually apply the tractor brake pedal to apply the brakes.

Releasing The Brakes - Release the tractor brake pedal to release the brakes.

6.9.4 Lock-Out Steering Instruction



WARNING

Failing to lock steering on hillsides could cause loss of control.

IMPORTANT

Turning with steer axles locked may result in equipment damage.

- Steering should be locked out for any high-speed traveling, such as road traveling with a full load, and also when operating on steep side hills. Failing to lock the steering in either scenario may result in unintended sideways movement of the mixer or increased tire wear.
- Steering is locked out by activating the SCV for this circuit for approximately 5 seconds. The operator knows the steering has been locked out when the tires are seen straightening themselves. After the steer axle tires are straightened, the operator can release the SCV to the neutral position.
- Steering should be unlocked when turning.
- When the operator wishes to return the steering function of the axles, the SCV should be returned to the float position.
- Note that for normal operation the SCV for this circuit should always be in the float position.
- When reversing with steer axles, start by driving forward to align the tractor and implement to the line you plan on reversing to. Lock the steering axles and back the implement in a straight line to the desired location.

6.10 OPTIONAL EQUIPMENT

Refer to scale indicator (Item 1) manufacturer's operators manual for operation.

See 8.5.2 Digital Scale Indicator for additional scale maintenance information.

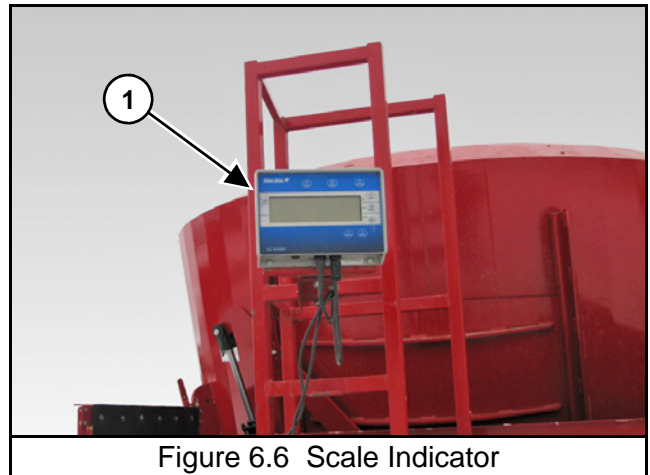

7.0 OPERATION

CAUTION

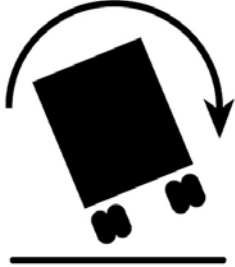

- **DO NOT** allow anyone to operate, service, inspect or otherwise handle this implement until all operators have read and understand all of the instructional materials in this Owner/ Operator's and Parts Manual and have been properly trained in its intended usage.
- **Before operating the implement, look in all directions to ensure there are no bystanders, especially small children, in the work area.**
- **Do not climb or step on any part of the implement at any time.**
- **Turn on level ground. Slow down when turning.**
- **Go up and down slopes, not across them.**
- **Keep the heavy end of the machine uphill.**
- **Do not overload the machine.**
- **Check for adequate traction.**

7.1 GENERAL

IMPORTANT

Always operate at the rated PTO speed but **DO NOT EXCEED THE RATED PTO SPEED**. If the mixer is operated faster than the rated PTO speed the strain on the drive train and mixer is greatly increased.

Do not force hay into the auger with loader or any other device.

Be aware of the overall size of the mixer to allow clearance through doorways.

The mixer is designed for blending dairy and beef rations. The mixer performance can vary according to the difference in material, loading sequence, mixing speed and unloading methods. The following guidelines should be understood before operating the mixer.

A new mixer will need an initial run-in period to polish the augers and mixer sides to achieve correct material movement inside the mixer. Until the unit is polished inside the user may experience material spillage, dead spots, or increased horsepower requirements. The load size may need to be reduced until the unit is polished inside.

7.1.1 Material



WARNING

Never hand feed material into mixer while it is running. Augers may cut or grab hands, clothing or material being loaded. Always stop the tractor's engine before hand loading materials.

Some feed materials will need to be processed alone in the mixer before they can be efficiently mixed with other feed materials.

- Large square or round bales of alfalfa
- Large square or round bales of high moisture content
- Large square or round bales of long mixed grasses, wheat or oat hay
- Large square or round bales of crop residue such as straw or soybean stubble
- Very light and bulky feed material

NOTE: Always remove any twine, net or plastic wrap from bales before loading into mixer.

7.1.2 Cutout Clutch

The clutch is designed to limit the amount of torque transferred to the machine through the driveline. If excessive torque is developed the clutch will disengage. A loud ratcheting sound will be heard and the transfer of power to the machine will be disrupted. This may occur when mixing or unloading a heavy mix or if an obstruction has lodged within the mixer. This is to protect the driveline from damage. To re-engage the machine, simply shut down the PTO and allow the driveline to come to a stop. The PTO can then be re-engaged to restart the mixer. The cutout clutch will either re-engage upon shut down of the PTO or just before it comes to a complete stop.

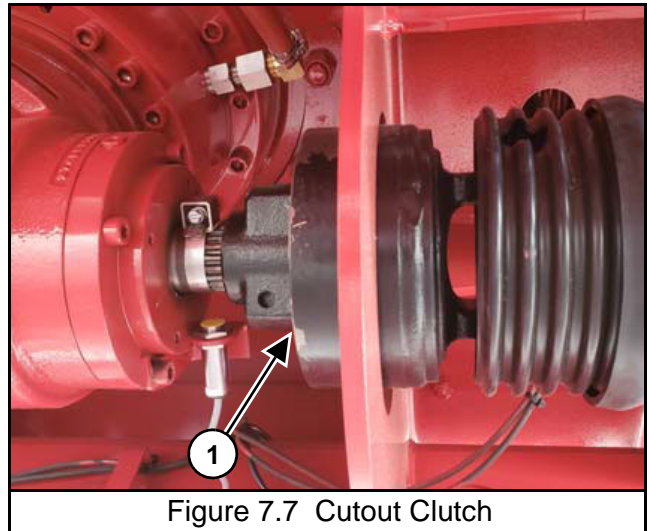

Figure 7.7 Cutout Clutch

7.2 LOADING



DO NOT ENTER MIXING CHAMBER WHILE MIXER IS RUNNING! Shutoff and lockout power before attempting to clear an obstruction or to perform work inside the mixing chamber. Refer to section 5.3 SHUTOFF & LOCKOUT POWER.



Be aware of power lines and other overhead obstructions when loading with a telescopic arm or loader.



Shutoff and lockout power before adjusting, servicing, maintaining, or clearing an obstruction from this machine. Refer to section 5.3 SHUTOFF & LOCKOUT POWER.

Comply with the safety instructions stipulated in the User Manuals for the operation / handling equipment used for loading the mixer.

Do not climb or step onto the platform or ladder before the parking brake has been applied.

When loading from a raised bay or platform, adopt the necessary measures (safety rails, etc.) to avoid people or equipment from falling into the machine.



Overloading may cause failure of axles, tires, structural members, hitches, loss of vehicle control. DO NOT exceed maximum gross weight.

If cooling power fault light is flashing, overheating of gearboxes will occur. Refer to section 8.10 MIXER TROUBLESHOOTING GUIDE.

NOTES:

- *Overloading can have detrimental effects on the integrity of the implement and it's safe use. Overloading will void warranty and increase risk to the operator's safety. Always be aware of your gross weight.*
- *If backing into the loading area is required, follow Section 6.9.4 Lock-Out Steering Instruction when backing up.*

Before loading, especially in freezing weather, make sure the augers are free to rotate and the discharge door moves freely up and down.

MATERIAL	LBS / CU.FT.
Soybeans	47 lbs.
Cotton Seed (Dry)	20 lbs.
Corn (Shelled)	45 lbs.
Corn Silage	30 lbs.
Haylage	20 lbs.
Sawdust	17 lbs.

NOTE: Maximum Gross Weight is the lesser value between the implement or tires.

MODEL	MAXIMUM MIXER GROSS WEIGHT	TOTAL NET WEIGHT (LBS)	CU. FT. CAPACITY**

** Struck capacity, heaped loads significantly increase weight.

When loading material into the mixer with an end-loader, dump the material into the center of the mixer.

1. Be sure that mixer is parked on a level surface.
2. The tractor should be straight in line with the mixer.
3. Completely close the mixer discharge door(s).
4. Set hay stops according to the instructions in this manual. See section 7.7 HAY STOP ADJUSTMENT.
5. Enter the tractor and start the engine.
6. Engage the PTO / hydraulics.
7. Set the tractor engine to operate at approximately 3/4 of rated PTO speed.
8. Load baled hay into the center of the mixer.
9. Allow mixer enough time to process the bale before adding other ingredients (4-10 minutes).

NOTES:

- **Processing of long stem forages will continue as other materials are added and mixed. Be careful not to over process these materials before adding other ingredients.**
- **Mixers equipped with a stop & shift gearbox or power shift transmission can process roughages in “Low” or “High” depending on how fast the bale needs to be processed. Mix all other materials in “Low”.**

7.2.1 Loading Sequence

IMPORTANT

Load all ingredients as quickly as possible. Allow a final mix time of 3-7 minutes, or whenever the load looks consistently mixed.

Never load long stem bales last. They will not be processed or mixed into the ration and may cause unloading difficulties or spillage.

NOTE: The loading sequence could vary.

The following is an example of a typical loading sequence:

1. Load and process long stemmed materials.
2. Load haylage and corn silage.
3. Load minerals, proteins and other small quantity ingredients.
4. Load grains, wet and dry commodities, etc.
5. Load all liquid fats, water and other liquids. Always load liquids at the center of the mixing chamber.

7.3 MIXING



DO NOT ENTER MIXING CHAMBER WHILE MIXER IS RUNNING! Shutoff and lockout power before attempting to clear an obstruction or to perform work inside the mixing chamber. Refer to section 5.3 SHUTOFF & LOCKOUT POWER.



Always operate at the rated PTO speed but **DO NOT EXCEED THE RATED PTO SPEED**. If the mixer is operated faster than the rated PTO speed the strain on the drive train and mixer is greatly increased.

Do not force hay into the auger with loader or any other device.

If cooling power fault light is flashing, overheating of gearboxes will occur. Refer to section 8.10 MIXER TROUBLESHOOTING GUIDE.

Normal mixing speed is 3/4 to full rated PTO speed. Time available to mix, thoroughness of the mix, and ingredients are all factors that must be considered when deciding on when and how fast to operate the mixer.

7.3.1 Mixing Troubleshooting Guide

PROBLEM	POSSIBLE SOLUTIONS
Forage Is Cut Too Short	<ul style="list-style-type: none"> • Reduce the initial processing time. • Adjust hay stops to a less aggressive or neutral position. (See Section 7.7 HAY STOP ADJUSTMENT) • Reduce total loading time. • Reduce the mixer RPM to limit aggressiveness in processing. • Modify the knife type, quantity, setting or placement. • Shift power shift transmission into “Low”.
Spillage Is Occurring	<ul style="list-style-type: none"> • Reduce Load Size. • Reduce tractor and/or mixer RPM. • Make sure machine is level. • The load size may need to be reduced until the unit is polished inside. • Adjust hay stops to a less aggressive or neutral position. • Adjust knives to a less aggressive position. • If spillage still occurs, the optional side extensions or hay retention ring may need to be installed.
Dead Spots	<ul style="list-style-type: none"> • The load size may need to be reduced until the unit is polished inside. • The auger scraper may need to be adjusted. (See Section 8.3.5 Auger Scraper Plate)

7.4 PLATFORM OPERATION

Park the tractor on a flat, level surface.

Engage the parking brake.

NOTE: Always maintain a three-point contact at all times when getting on and off the ladder. Use the ladder rails and steps when climbing the ladder.

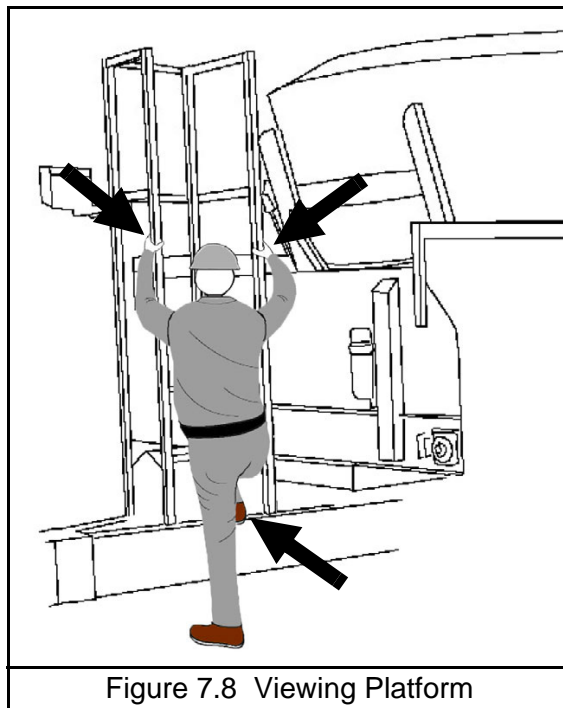

Figure 7.8 Viewing Platform

7.5 UNLOADING



DO NOT ENTER MIXING CHAMBER WHILE MIXER IS RUNNING! Shutoff and lockout power before attempting to clear an obstruction or to perform work inside the mixing chamber. Refer to section 5.3 SHUTOFF & LOCKOUT POWER.



Shutoff and lockout power before adjusting, servicing, maintaining, or clearing an obstruction from this machine. Refer to section 5.3 SHUTOFF & LOCKOUT POWER.



If cooling power fault light is flashing, overheating of gearboxes will occur. Refer to section 8.10 MIXER TROUBLESHOOTING GUIDE.

NOTES:

- *Unload the mixed ration within a short time of mixing. A fully loaded mixer which is bounced over rough terrain or allowed to settle will require more horsepower during start-up.*
- *If backing into the loading area is required, follow Section 6.9.4 Lock-Out Steering Instruction when backing up.*

1. Enter the tractor, start the engine, release the parking brake.
2. Move the tractor and mixer to the unloading area.
3. Be sure that mixer is parked on a level surface.
4. The tractor should be straight in line with the mixer.
5. Shift front sliding conveyor into working position or lower slide tray / conveyor (if equipped).

NOTE: Mixers equipped with a power shift transmission will automatically shift to low if the PTO RPM drops below 600 RPM while in “High”.

6. Shift the gearbox into “Low” to ease the start of a full load for unloading.
7. Engage the PTO.
8. Set the tractor engine to operate at approximately 1/2 of rated PTO speed.
9. Open discharge door slowly to adjust the amount of material to be discharged. Adjust door height or conveyor speed for desired flow of feed.
10. After the load begins to discharge, increase the tractor RPM to full rated PTO speed to ensure fast and thorough clean out while driving forward along the discharge path.
11. During the unloading process, the mixer can be shifted into “High”. See section 6.8.1 Controls for more details. This will help remove any feed remaining on the augers and assist in keeping an even flow until the mixer is empty.
12. When finished unloading, reduce engine speed to idle and disengage the PTO / hydraulics.
13. Move the mixer forward, away from the unloaded material.
14. Close the discharge door.
15. Shift front sliding conveyor into storage position or raise slide tray / conveyor (if equipped).
16. Park the mixer on a flat, level surface.
17. Engage the parking brake, stop the engine and exit the tractor.

7.6 UNHOOKING THE TRACTOR



WARNING

Keep hands, legs and feet from under tongue and hitch until jack is locked into place.

Jack is not designed to support the implement when it is loaded.

1. Park the implement on level ground. Put the tractor controls in neutral, set the parking brake, and turn the engine off before dismounting.
2. Place wheel chocks in front and in back of the implement wheels on opposite sides to prevent the implement from rolling after the tractor is unhooked.
3. Disconnect the PTO drive shaft.
4. Remove the hydraulic hose ends from the tractor hydraulic ports and secure the hose ends in the key slot holes on the front of the mixer to keep them clean.
5. Remove the light cords and any optional equipment connections.
6. Remove the jack from the storage mount and reinstall the jack on the hitch tongue. Crank the jack down until the hitch lifts off the tractor drawbar.
7. Remove the hitch pin.
8. Unhook safety chain from tractor drawbar and intermediate support.
9. Slowly drive the tractor away from the implement.

7.7 HAY STOP ADJUSTMENT

CAUTION

DO NOT adjust the hay stops while the mixer is running. Moving feed inside the mixer can make the hay stop move suddenly causing injury to the person making the adjustment.

IMPORTANT

Never operate the mixer without the hay stop lock bolt installed.

7.7.1 Hay Stop Lock Bolt

The hay stop lock bolt (Item 1) prevents the hay stop from rotating past the intended range of operation. If the hay stop bolt and the positioning pin (Item 2) are removed, the hay stop could contact the moving auger and cause damage to the hay stop and auger.

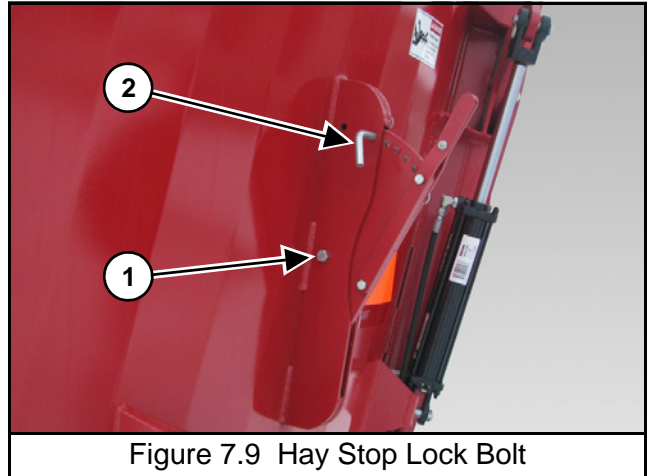

Figure 7.9 Hay Stop Lock Bolt

Position	Setting	Material
A	High	Light And Bulky Material (Dry Grasses)
B	Medium High	Alfalfa Bales And Other Forages
C	Neutral	Unrestrained Movement Of Feed
D	Medium Low	Heavier Rations
E	Low	Aggressive Cutting

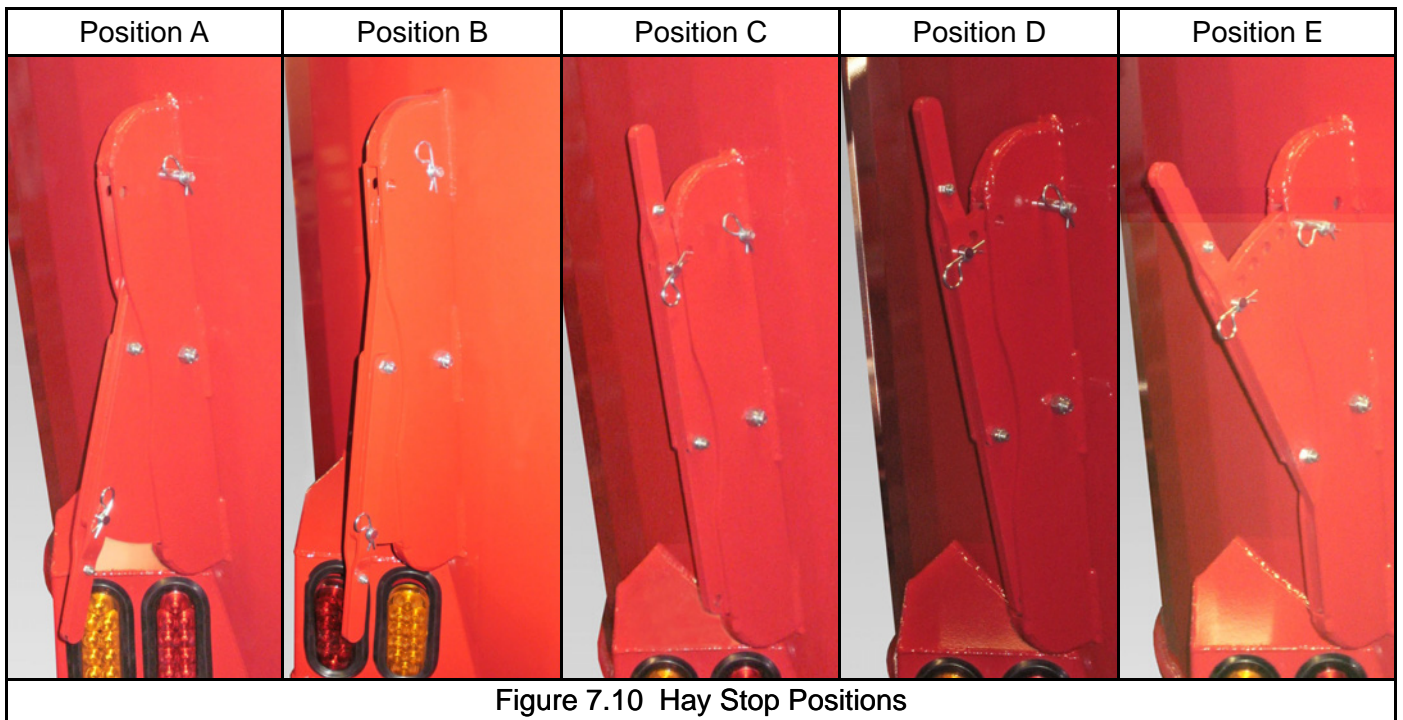

Figure 7.10 Hay Stop Positions



8.0 MAINTENANCE

8.1 GENERAL



Shutoff and lockout power before adjusting, servicing, maintaining, or clearing an obstruction from this machine. Refer to section 5.3 SHUTOFF & LOCKOUT POWER.

IMPORTANT

When welding do not allow electrical current to flow through bearings, roller chains, or scale weigh bars. Ground the welder directly to the part being welded. Always disconnect the power cord from scale indicator before welding.

8.2 LUBRICATION



Shutoff and lockout power before adjusting, servicing, maintaining, or clearing an obstruction from this machine. Refer to section 5.3 SHUTOFF & LOCKOUT POWER.

IMPORTANT

Fluid such as hydraulic fluid, grease, etc., must be disposed of in an environmentally safe manner. Some regulations require that certain spills and leaks on the ground must be cleaned in a specific manner. See local, state and federal regulations for the correct disposal.

The PB-ADR-B manual should be used in conjunction with this manual.

NOTES:

- *Use a grease type that is composed of a high quality lithium complex or better, unless otherwise stated. We recommend using a #1 grade in colder temperatures or a #2 grade in warmer temperatures.*
- *We recommend using a 4-jaw grease coupling to allow greasing of both imperial and metric style grease fittings.*
- *Over lubrication is a major cause of bearing failures. Please lubricate conservatively when unsure of bearing requirements.*
- *Do not mix synthetic and mineral oils.*

8.2.1 Daily Lubrication

Check the planetary gearbox oil levels daily to prevent abnormal component wear. Add new oil to the planetary reservoir tank (See 8.2.11.1 Planetary Gearbox) if the oil level is not at the oil reservoir mark (Item 1).

Check for any oil leaks. If leaks occur, correct the source of the leak.

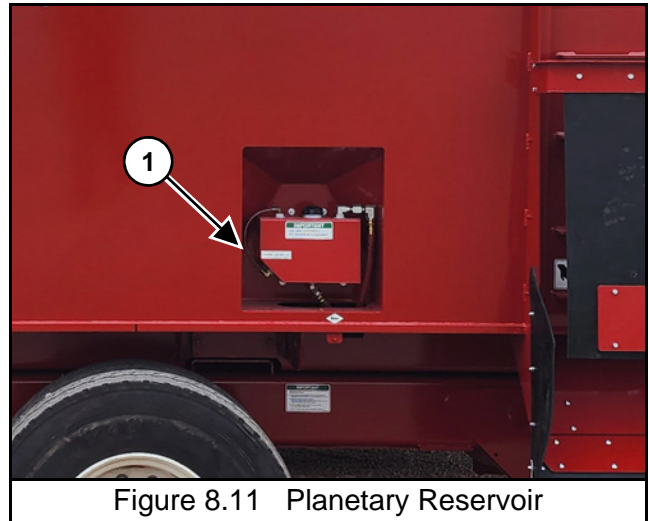

Check the power shift transmission oil level daily to prevent abnormal component wear. Add new oil to the transmission. Add new oil to the power shift transmission (See 8.2.11.2 Power Shift Transmission) if the oil level is not at the sight glass (Item 2).

Check for any oil leaks. If leaks occur, correct the source of the leak.

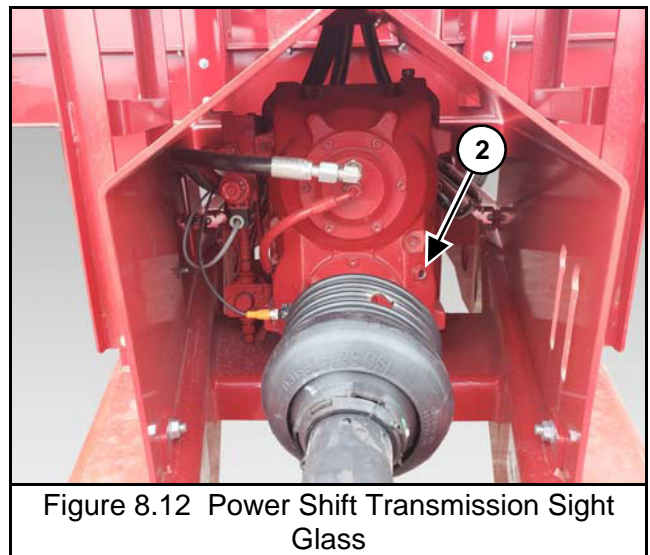

8.2.2 Every 8 Hours

Grease all PTO driveline zerks

1. Grease PTO locations every 8 hours.
2. Lubricate the outer CV cross kit with about 5 pumps of grease every 8 hours.
3. Grease telescoping members until it adequately covers the sliding members every 8 hours. Take apart occasionally to make sure adequate lubrication is being added. Take apart each season to be cleaned with solvent and re-coated with grease before re-assembling.
4. Lubricate the inner CV cross kit with about 15 pumps of grease every 8 hours.
5. Lubricate the double yoke with about 10 pumps of grease every 8 hours.

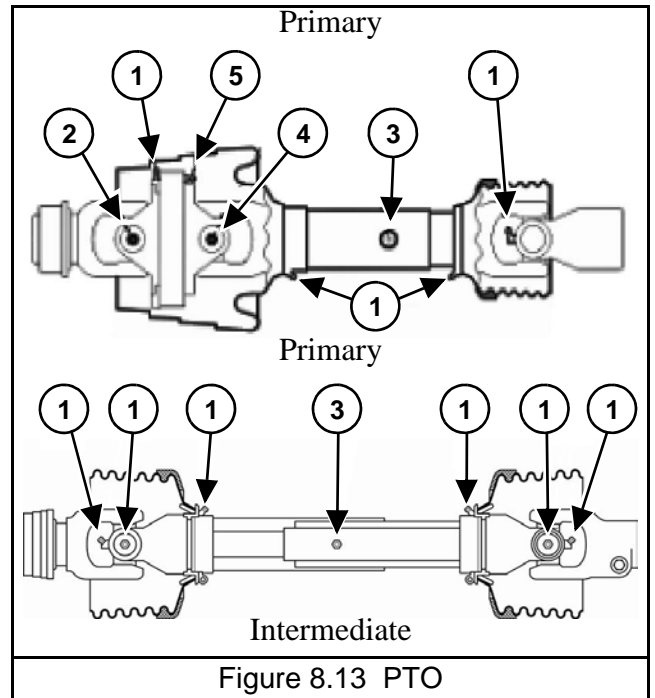

Figure 8.13 PTO

8.2.3 Monthly Lubrication

Clean out under chain return shield (Item 1) (If Equipped).

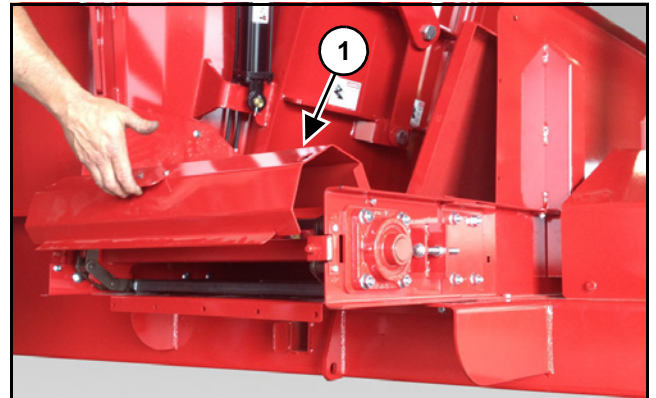
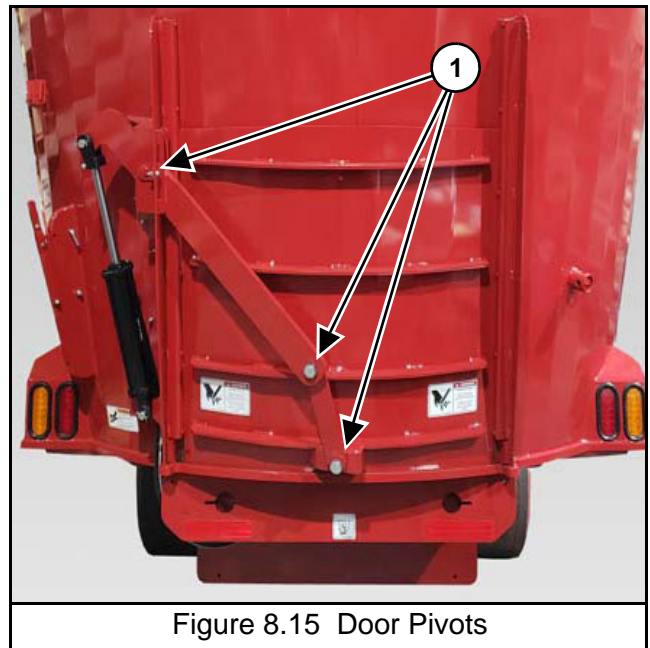

Figure 8.14 Front Chain Conveyor Return

Grease weigh bar mounts (If mounts are equipped with grease zerks).

8.2.4 Every 40 Hours

Oil door pivots (Item 1).



8.2.5 First 50 Hours

First oil change in the planetaries (See 8.2.11.1 Planetary Gearbox).

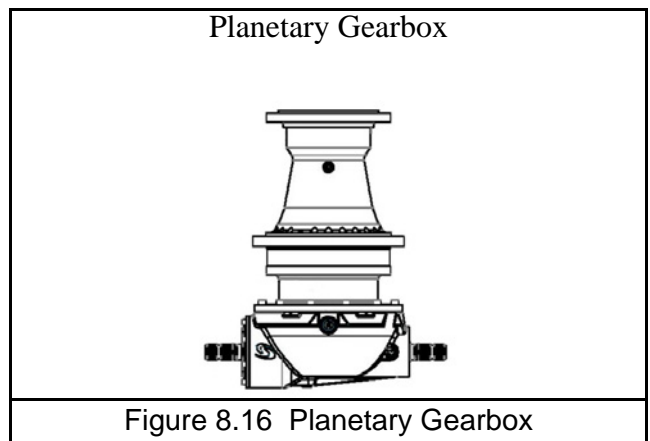

8.2.6 Every 250 Hours

Grease the four (4) front cross conveyor bearings (Item 1) (If Equipped).

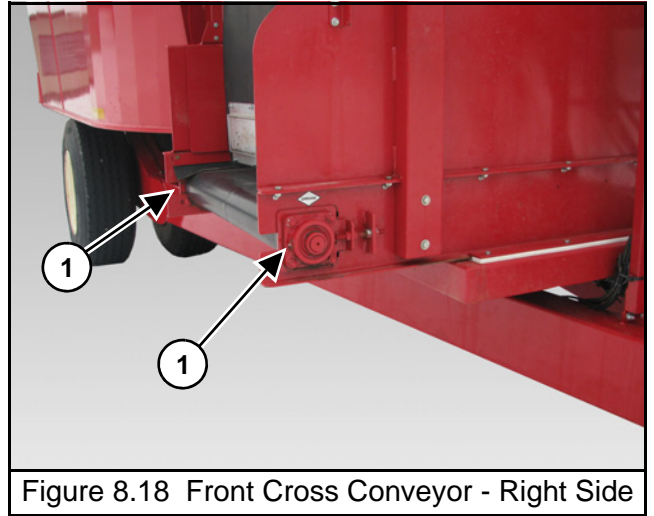
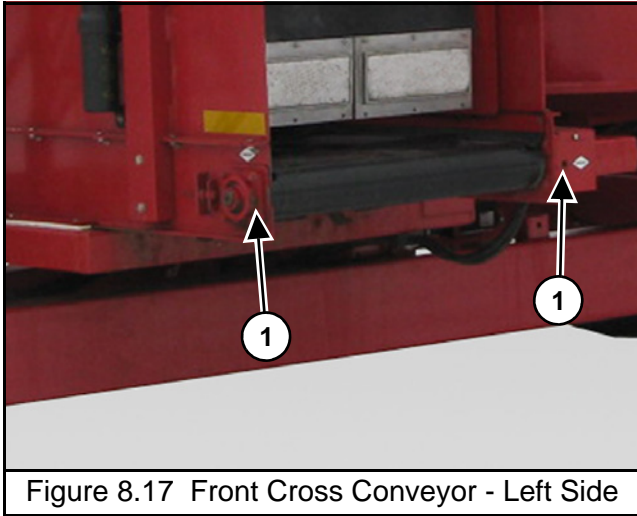

Grease the four (4) side door conveyor bearings (Item 2) (both sides) (If Equipped).

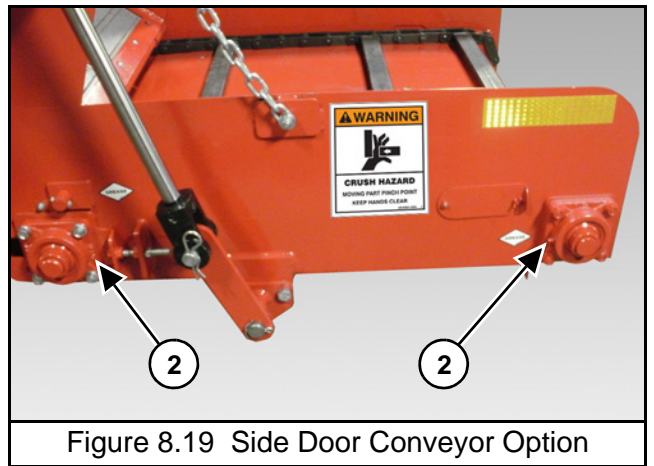

8.2.7 Every 500 Hours

Grease all planetary bearings with 1 pump of grease (Item 1). **Be careful not to over grease.**

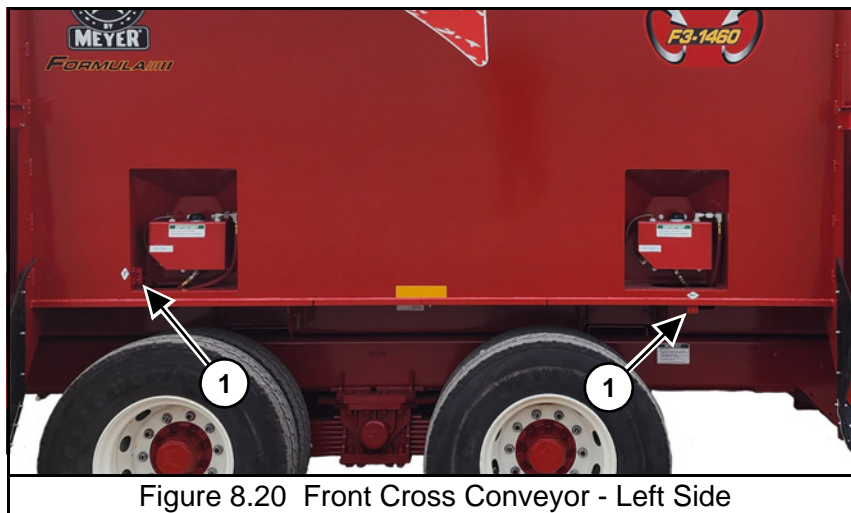

8.2.8 Annually or Every 1000 Hours (Whichever Is First)

Change the power shift transmission oil and filter. (See 8.2.11.2 Power Shift Transmission)

(Filter Element Part Number: 119-Z-01-1)

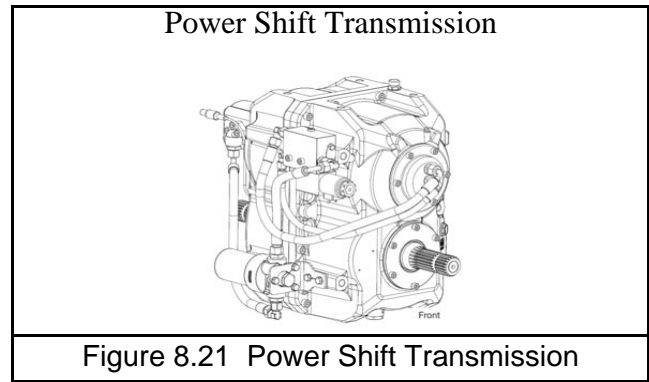

8.2.9 Annually or Every 2000 Hours (Whichever Is First)

Change oil in the planetary gearboxes. (See 8.2.11.1 Planetary Gearbox)

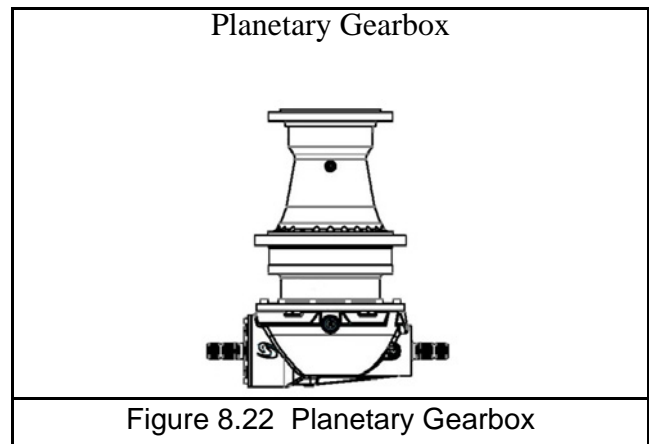

8.2.10 Every 5000 Hours

Replace all planetary bearings.

Change external planetary O-rings.

Check the extent of wear on all planetary gears.

8.2.11 Gearbox/Transmission Oil & Filter Change Procedures



CAUTION

Shutoff and lockout power before adjusting, servicing, maintaining, or clearing an obstruction from this machine. Refer to section 5.3 SHUTOFF & LOCKOUT POWER.

IMPORTANT

Fluid such as hydraulic fluid, grease, etc., must be disposed of in an environmentally safe manner. Some regulations require that certain spills and leaks on the ground must be cleaned in a specific manner. See local, state and federal regulations for the correct disposal.

NOTES:

- *In order to avoid sludge deposits, change the oil while the gear unit is still warm.*
- *For an effective oil change, the unit should be flushed with a liquid detergent recommended by the lubricant supplier.*
- *The mixer should be level when changing gearbox oil.*

8.2.11.1 Planetary Gearbox

Draining

- Place a container of sufficient capacity under the gearbox (Item 4). Remove the planetary reservoir (Item 2) cap (Item 3).
- Drain the planetary by removing the drain plug from the T-fitting (Item 5).

Filling

Filling with an oil pump:

(Call the factory to purchase an oil pump kit, Part #: VA-OP.)

- Connect oil pump to the T-fitting (Item 5) and fill with oil until the reservoir (Item 2) fills to the oil level indicator (Item 1).
- Reinstall the reservoir cap.
- Quickly remove the oil pump from the T-fitting and reinstall the plug.
- Run the mixer with no load for a few minutes.

NOTE: See Planetary Lubrication Specifications table for oil type and approximate capacities.

- Inspect the reservoir breather, make sure it is not plugged, and check for leaks.

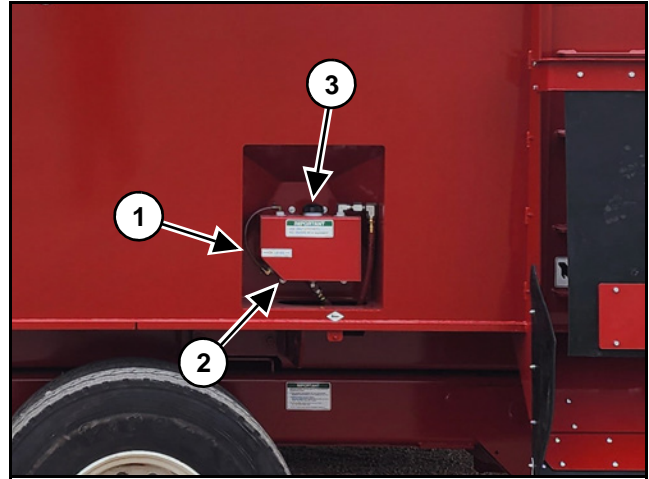

Figure 8.23 Planetary Reservoir

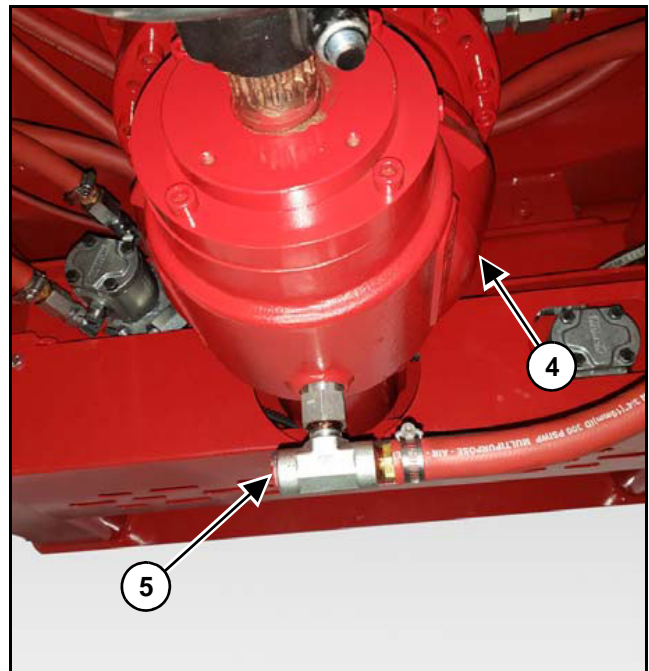

Figure 8.24 Planetary Drain Plug

PLANETARY LUBRICATION SPECIFICATIONS				
Model	Part Number	Description	Oil Type	Capacity Per Planetary (Including Reservoir) (Approximate)
1460	119-30-24.3-2	3003 Planetary 24.3:1	Synthetic ISO 220 Or Equivalent	32 Quarts

8.2.11.2 Power Shift Transmission

IMPORTANT

Check the transmission oil levels regularly to prevent abnormal component wear. Add oil to the transmission if oil level is not at the oil level mark.

Draining

- Be sure the mixer is positioned on level ground/ surface.
- Place a container of sufficient capacity under the transmission.
- Drain the unit by removing the plug from the bottom of the transmission.
- After the unit is completely drained, reinstall the plug.

Filter Replacement

- Remove filter housing (Item 1).
- Remove old filter.
- Lubricate the O-ring with clean oil.
- Apply aluminum paste or another suitable lubricant to the threads of the filter head and bowl.
- Place the new filter element carefully onto the element spigot.
- Screw the filter bowl on fully and then unscrew by a quarter of a turn.

Filling

- Remove breather/filler plug (Item 2).
- Fill transmission until the oil level has reached the sight glass (Item 3).

NOTE: See Power Shift Transmission Lubrication Specifications table for oil type and approximate capacities.

- Replace the breather/filler plug.
- Run the transmission with no load for a few minutes, switching from low to high gear several times.
- Check the oil level and add if necessary.
- Inspect the breather, make sure it is not plugged, and check for leaks.

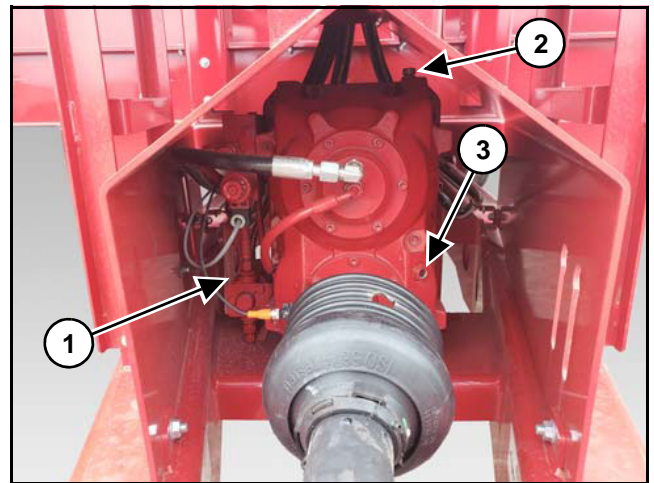

Figure 8.25 Power Shift Transmission

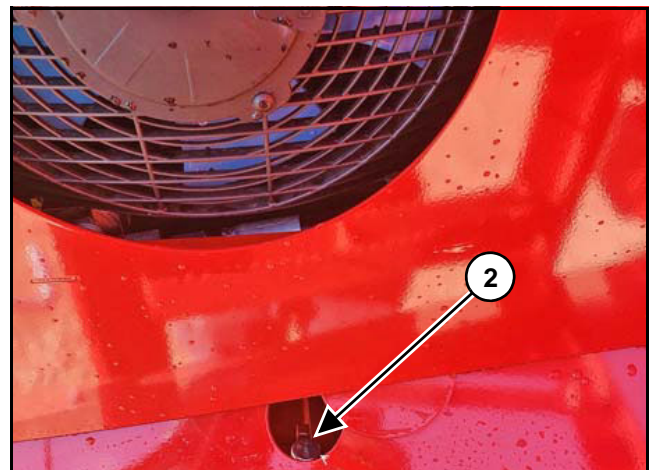

Figure 8.26 Transmission Breather/Fill Plug

POWER SHIFT TRANSMISSION LUBRICATION SPECIFICATIONS

Model	Part Number	Description	Oil Type	Capacity (Including Radiator & Filter) (Approximate)
1460	119-2SP-1.0-1.8-1	1.05:1 / 1.83:1	See Approved Fluid Table	6.2 Quarts Without Cooler Drained 8.2 Quarts With Cooler Drained (Optional)

POWER SHIFT TRANSMISSION FLUID (ATF) OIL						Revision: 00 Latest Update: 07-2017	
Supplier:	Product Name:	Viscosity @40°C:	Viscosity @100°C:	Viscosity Index:	Pour Point:	STATUS	
						Recommended	Approved
AGCO	AGCO POWER FLUID 411 ATF SAE 5W-20	35	7.2	174	-48°C		X
CASTROL	CASTROL TRANSMAX DEX III Multi-Vehicle	35	7.2	175	-46°C	X	X
CASTROL	CASTROL TRANSMAX Z	38	7.2	170	-66°C		X
CHEVERON	TEXACO TEXAMATIC 7045E	34	7.4	194	-51°C		X
EXXONMOBIL	MOBIL Multi-Vehicle ATF	34	7.4	193	-54°C		X
EXXONMOBIL	MOBIL DELVAC SYNTHETIC ATF	39	7.3	168	-54°C		X
KUWAIT PETROLEUM	Q8 Auto 15	36	8.0	200	-48°C		X
PETRONAS	TUTELLA TRANSMISSION GI/E	37	7.6	180	-48°C		X
SHELL	SHELL SPIRAX S4 ATF HDX	33	7.2	189	-48°C		X
SHELL	SHELL SPIRAX S6 ATF VM	34	7.4	185	-48°C		X
TOTAL	TOTAL FLUIDE XLD FE	34	7.1	181	-51°C		X
TOTAL	TOTAL FLUIDE G3	33	7.1	N/A	-45°C		X
TOTAL	TOTAL ELFMATIC G3	33	7.1	N/A	-45°C		X
TOTAL	TOTAL FLUIDE AT42	34	7.7	207	-51°C		X
VALVOLINE	HEAVY DUTY ATF PRO	36	7.2	172	-50°C		X
ATF-Oil With The Defined Specifications		<38	>7.0	>170	<-45°C		X

8.3 ADJUSTMENTS



Shutoff and lockout power before adjusting, servicing, maintaining, or clearing an obstruction from this machine. Refer to section 5.3 SHUTOFF & LOCKOUT POWER.

If work must be done inside the mixer, put a protective cover over the auger knives to avoid injury. The hopper and flighting may be slippery. Use caution when stepping on or standing inside the mixer.

8.3.1 Side Discharge Conveyor

To adjust tension of the chain, loosen the inner nut (Item 1) and either tighten or loosen the outer nut (Item 2) as needed. Count the number of turns you are adjusting so you can adjust the other end. Once you have proper tension, re-tighten the inner nut (Item 1) on both sides.

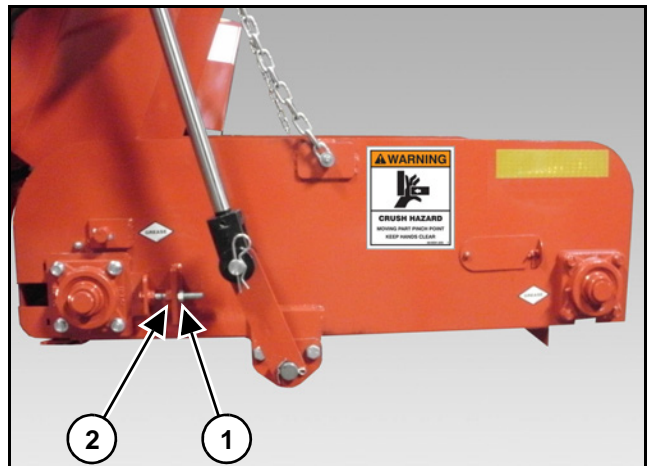

Figure 8.27 Side Discharge Conveyor

8.3.2 Belt Conveyor Tension

IMPORTANT

Check belt tension often. Belts can tighten with use. Overtightening can cause damage to belt.

Front Conveyor:

Tension the belt (Item 1) so as the belt is flush with the bottom radius (Item 2) of conveyor side rails.

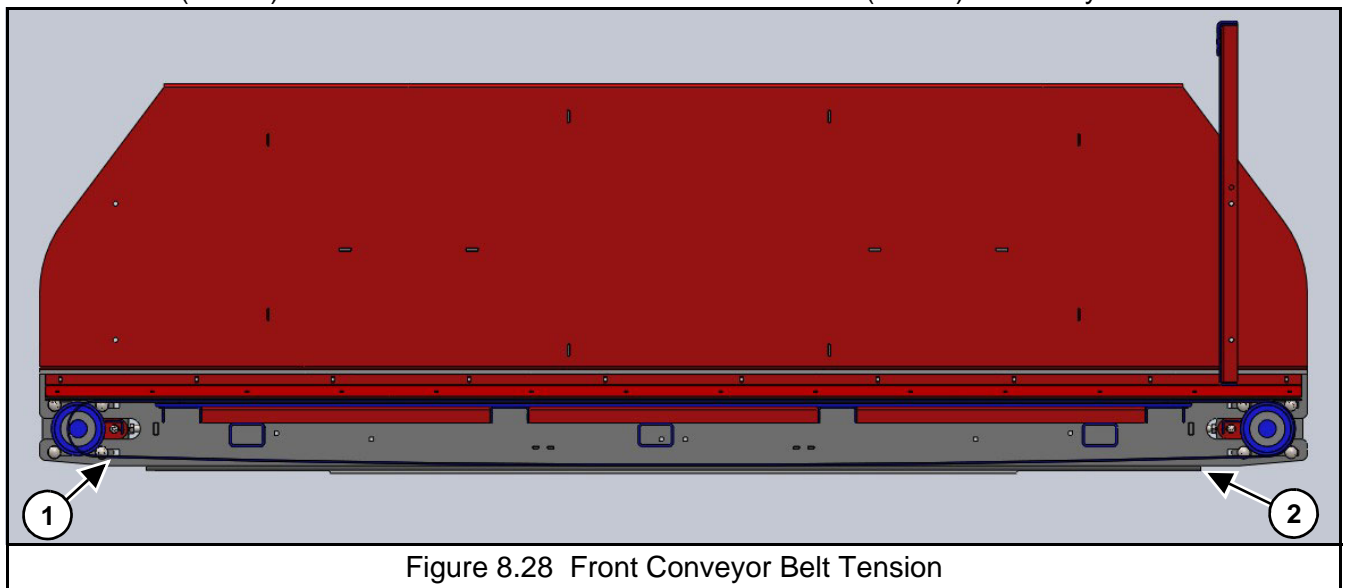

Figure 8.28 Front Conveyor Belt Tension

Incline/Side Discharge Conveyor:

Tension the belt (Item 3) so as the midpoint between both rollers sags 7/8" lower than at the rollers (Item 4).

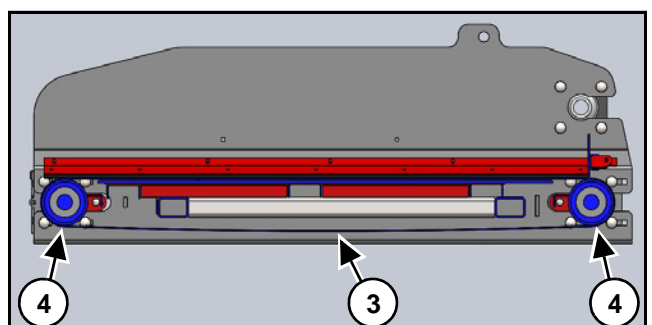

Figure 8.29 Incline/Side Conveyor Belt Tension

8.3.3 Tracking

NOTE: *The primary discharge side for the two motor flat conveyor is the side that is used for discharge the most.*

Step 1: Loosen the lock nuts (Item 1) holding the four bearings to the conveyor. Loosen the tightener nuts (Item 2) on all adjuster locations. Do not loosen the scraper bolts (Item 3).

Step 2: Locate the primary discharge side of the conveyor.

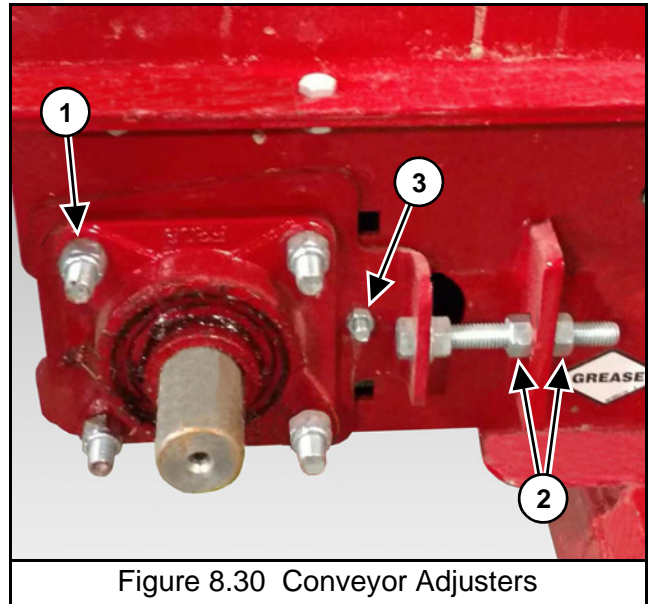

Figure 8.30 Conveyor Adjusters

Step 3: Set the primary side as follows:

Use the primary side adjusters to remove at least half of the belts slack. Measure, as shown below, until both sides of the drive pulley shaft (Item 4) are set at exactly the same from the end of the conveyor frame (Item 5).

Step 4: Once the primary drive pulley is set and square, tighten the lock nuts on both primary drive pulley bearings. Lock both adjusters on the primary drive pulley.

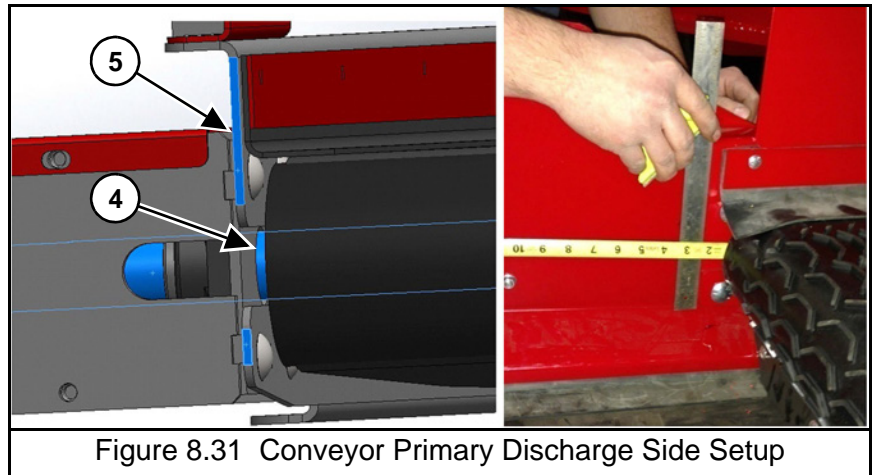

Figure 8.31 Conveyor Primary Discharge Side Setup

Step 5: With the primary discharge drive pulley set, move to the other side of the conveyor. Start to evenly tighten the belt by alternating sides on the non-primary discharge pulley adjusters. Tighten until the lowest hanging part of the belt is flush with the bottom of the conveyor frame. Once the belt is tight (Do not over tighten belt), measure the distance from the non-primary discharge shaft to the end of the conveyor frame, same as shown in Step 3. Do that for both shaft ends of the non-primary discharge pulley.

Step 6: Take the shortest measurement from either end and set both ends of the non-primary discharge pulley to the same measurement.

NOTE: *If you run out of adjustment on the non-primary side, repeat Step 3 and remove more slack from the belt using the primary side.*

Step 7: With the belt tightened as shown in section 8.3.2 Belt Conveyor Tension and the non-primary discharge pulley square with the conveyor frame, tighten the adjuster lock nuts for both non-primary discharge pulley bearings.

Step 8: Run the mixer conveyor for 2-3 minutes (both directions for front flat conveyors) at full RPM. If you notice the belt walking to the left or right while looking at the primary discharge end of the conveyor, stop the conveyor. Check your measurements to make sure both primary and non-primary discharge pulleys are square with the conveyor frame. If the conveyor pulleys are square but the belt continues to walk, use the images below to unlock and tighten the corresponding non-primary discharge pulley bearing adjuster (See Below). Continue to slightly adjust and run the conveyor until the belt stops walking.

NOTE: *If the center v of the belt is completely out of the pulley groove, you may have to loosen both non-primary pulley adjusters to center the belt. Re-tighten to your measurement used in Step 6 before adjusting the conveyor as shown below.*

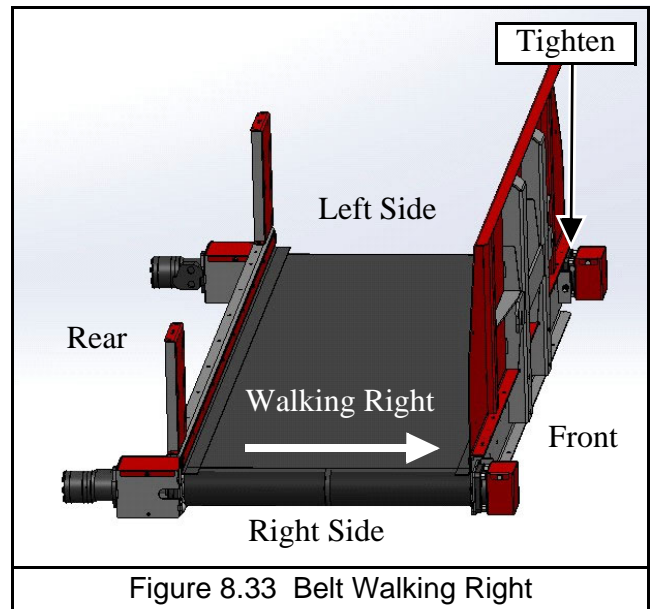
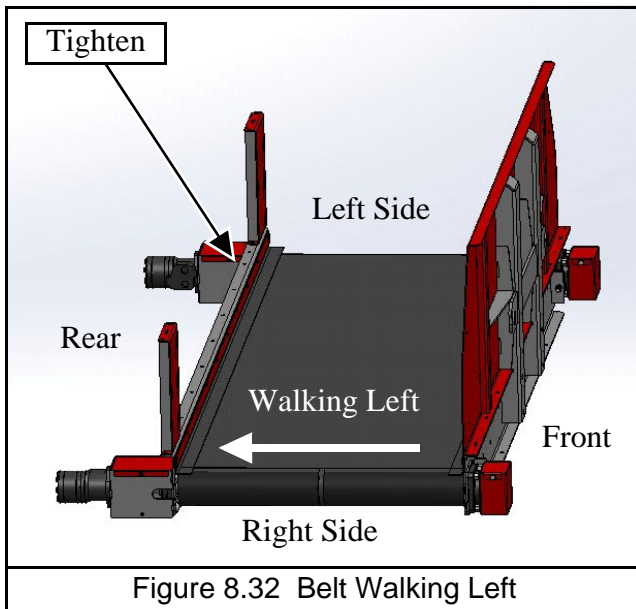

NOTE: *Both images are viewed as if the conveyor is a right primary discharge.*

Step 9: With the belt conveyor tracking properly, make sure all bearing bolts are tight and adjusters are locked.

Step 10: Watch the conveyor when discharging your feed ration to make sure the belt doesn't slip. If the belt is slipping, evenly tighten the non-primary discharge side. Run and check belt alignment. Repeat as necessary.

Step 11: Watch the conveyor when discharging your feed ration to make sure the belt doesn't slip. If the belt is slipping, evenly tighten the non-primary discharge side. Run and check belt alignment. Repeat as necessary.

NOTE: *If you run out of adjustment on the non-primary side, repeat Step 3 and remove more slack from the belt using the primary side.*

8.3.4 Front Discharge Conveyor - Chain

To adjust tension of the chain, loosen the inner nut (Item 1) and either tighten or loosen the outer nut (Item 2) as needed. Count the number of turns you are adjusting so you can adjust the other end. Once you have proper tension, re-tighten the inner nut (Item 1) on both sides.

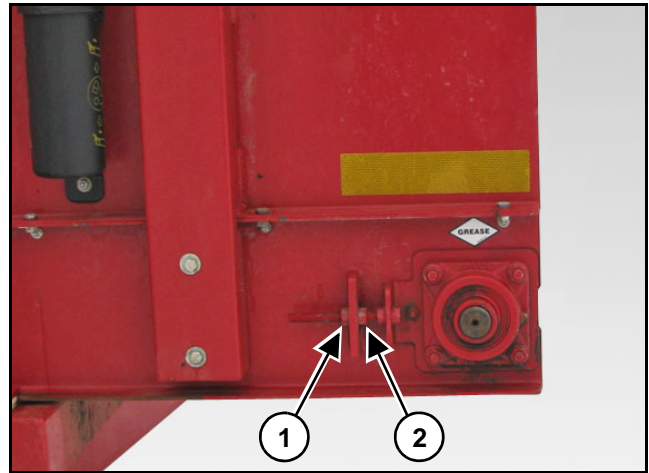

Figure 8.34 Chain Conveyor Adjusters

8.3.5 Auger Scraper Plate

Check the auger scraper monthly for proper clearance with the side panel. Locate the closest point along the augers rotation that the scraper comes to the baffles. Adjust the scraper to a 1/16" from the located closest point as shown in the image.

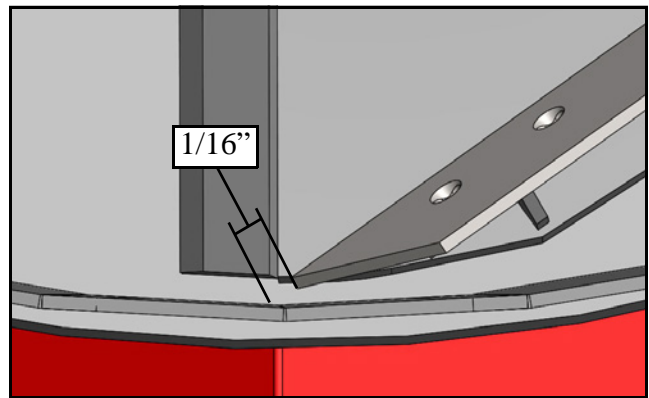

Figure 8.35 Auger Scraper Plate

8.3.6 Auger Timing

Auger timing is critical. Whenever disconnecting the PTO connecting the three planetaries, it is critical that all the auger lead edges be facing the front of the mixer as shown.

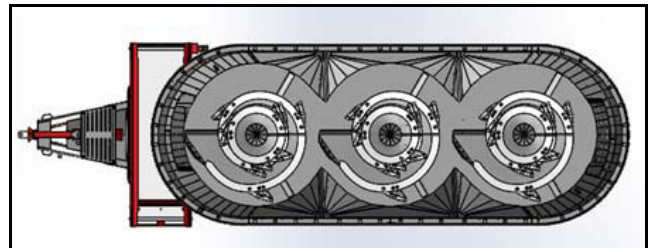

Figure 8.36 Auger Timing

8.3.7 PTO Cutout Clutch Connection

The cutout clutch end of the PTO driveline must always be attached to the implement. The PTO driveline is equipped with a 1-3/4" x 20 spline on the implement half for attaching to the spreader. Remove the M17-hexagon bolt from the splined hub and slide the PTO onto the implement splined input shaft. Install the hexagon bolt (Item 1) through the hub being sure the bolt is falling into the groove on the splined shaft. Torque tight using a metric size M17 6-point socket and torque down to 75 ft. lbs. A M17 6-POINT METRIC SOCKET MUST BE USED AS ROUNDING OF HEXAGON BOLT AND INACCURACY OF TORQUE SETTINGS COULD OCCUR.

If removal of the M-17 hexagon bolt is necessary, use the same M-17 6-point socket and loosen bolt 1/2 turn. Insert a 1/4" drift punch in the hole on the opposite side of the hexagon bolt and tap to loosen the seated portion of the bolt from the splined hub. Loosen in 1/4 turn increments and tapping to loosen. After bolt seat has been released, remove the bolt. If bolt is not unseated, damage to the hexagon bolt will occur.

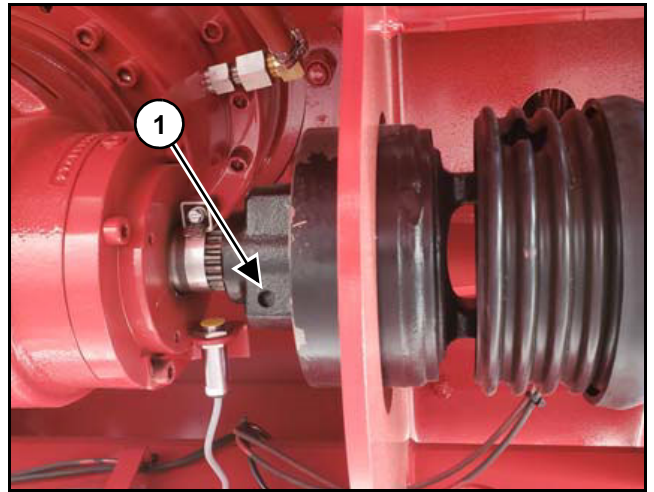

Figure 8.37 Cutout Clutch Connection

8.3.8 Knives

Knives are designed and intended for processing and mixing rations that include long stem forages.

NOTE: Some rations may require adding or removing knives, or changing knife position to obtain the desired result.

8.3.8.1 Knife Removal

Individual knives may be removed from the auger if the ration does not include hay or includes very small amounts of small square bale hay or tub ground hay. Removing knives will decrease the aggressive cutting action on the stem length of the ration and may also reduce horsepower requirements.

8.3.8.2 Adding Knives

If the hay in your ration is not being processed enough or fast enough extra knives may be ordered through your dealer. Adding extra knives will help break down and process materials faster, but may increase the horsepower required to process and mix.

8.3.8.3 Knife Placement

The placement of knives towards the bottom of the auger will process the forage faster and make the stem length shorter but may require more horsepower. Placement of knives higher on the auger will assist in breaking up bales faster after initial loading.

8.3.8.4 Knife Position

“Out” Position

When the knives are in the “out” position they tend to move the long stem hay and lighter bulky materials best in the early stages of processing and mixing. This setting may result in feed spillage in certain materials. Knives placed in this setting are very aggressive in processing feed and will also cause an increase in horsepower requirement.

“In” Position

When the knives are in the “in” position they will slow down the long stem hay and lighter bulky materials in the early stages of processing and mixing. Less spillage will occur due to clearance between the knives. This setting is more desirable for heavy rations with long run time and where over processing can occur. Knives placed in this position are less aggressive in processing feed and will reduce the horsepower requirement.

8.3.8.5 Replacing Damaged or Worn Knives

When knives become worn and rounded on the leading edge their efficiency is greatly reduced. This results in longer processing times and increased horsepower requirements. Refer to your parts manual and contact your Meyer MFG dealer for replacement part ordering.

8.3.9 Brake Adjustment

Take up the slack when the stroke reaches about two thirds of the maximum travel. Adjust the slack adjuster until the brake shoes make contact with the drum. It may be necessary to jack the tire off of the ground and rotate the tire to feel contact with the drum. Once contact is felt back off the adjuster bolt on the slack adjuster 1/2 turn or until wheel turns freely without drag. Repeat the same process for the remainder of the brakes.

8.4 FASTENER TORQUE SPECIFICATIONS



Shutoff and lockout power before adjusting, servicing, maintaining, or clearing an obstruction from this machine. Refer to section 5.3 SHUTOFF & LOCKOUT POWER.

After an initial break in period approximately four months and periodically thereafter, ALL bolts and nuts should be checked to ensure that recommended torque values are being maintained.

8.4.1 General Torque Specifications

IMPORTANT

DO NOT use these values if a different torque value or tightening procedure is given for a specific application. Torque values listed are for general use only and include a + or - 10% variance. Check tightness of fasteners periodically. DO NOT use air powered wrenches.





Head Marking	Grade and Material	Nominal Size Range (inches)
 No Markings	Grade 2 Low or medium carbon steel	1/4" thru 3/4" Over 3/4" thru 1-1/2"
 3 Radial Lines	Grade 5 Medium carbon steel, quenched and tempered	1/4" thru 1" Over 1" thru 1-1/2"
 6 Radial Lines	Grade 8 Medium carbon alloy steel, quenched and tempered	1/4" thru 1-1/2"
 A325	Grade A325 Carbon or Alloy Steel with or without Boron	1/2" thru 1-1/2"
Stainless markings vary. Most stainless is non-magnetic	18-8 Stainless Steel alloy with 17-19% Chromium and 8-13% Nickel	All Sizes thru 1"

Figure 8.39 SAE Bolt Grade



Head Marking	Class and Material	Nominal Size Range (mm)
 8.8	Class 8.8 Medium carbon steel, quenched and tempered	All Sizes below 16mm 16mm - 72mm
 10.9	Class 10.9 Alloy steel, quenched and tempered	5mm - 100mm
 12.9	Class 12.9 Alloy steel, quenched and tempered	1.6mm - 100mm
Stainless markings vary. Most stainless is non-magnetic. Usually stamped A-2.	A-2 Stainless Steel alloy with 17- 19% chromium and 8-13% nickel	All Sizes thru 20mm

Figure 8.38 Metric Bolt Grade

SAE				
	Grade 5, 5.1 & 5.2		Grade 8 & 8.2	
Size (inches)	Lubricated (lb-ft)	Dry (lb-ft)	Lubricated (lb-ft)	Dry (lb-ft)
1/4	7	9	10	12.5
5/16	15	18	21	26
3/8	26	33	36	46
7/16	41	52	58	75
1/2	63	80	90	115
9/16	90	115	130	160
5/8	125	160	160	225
3/4	225	280	310	400
7/8	360	450	500	650
1	540	675	750	975
1-1/8	675	850	1075	1350
1-1/4	950	1200	1500	1950
1-3/8	1250	1550	2000	2550
1-1/2	1650	2100	2650	3350

METRIC								
	Class 4.8		Class 8.8 & 9.8		Class 10.9		Class 12.9	
Size (mm)	Lubricated (lb-ft)	Dry (lb-ft)	Lubricated (lb-ft)	Dry (lb-ft)	Lubricated (lb-ft)	Dry (lb-ft)	Lubricated (lb-ft)	Dry (lb-ft)
M6	3.5	4.5	6.5	8.5	9.5	12	11.5	14.5
M8	8.5	11	16	20	24	30	28	35
M10	17	21	32	40	47	60	55	70
M12	29	37	55	70	80	105	95	120
M14	47	60	88	110	130	165	150	109
M16	73	92	140	175	200	225	240	300
M18	100	125	195	250	275	350	325	410
M20	140	180	275	350	400	500	460	580
M22	190	250	375	475	540	675	625	800
M24	250	310	475	600	675	850	800	1000
M27	360	450	700	875	1000	1250	1150	1500
M30	490	625	950	1200	1350	1700	1600	2000
M33	675	850	1300	1650	1850	2350	2150	2750
M36	850	1075	1650	2100	2350	3000	2750	3500

8.4.2 Wheel Torque

BOLT/STUD SIZE	SOCKET SIZE	PRESS FORMED WHEEL CENTER	BOLT TYPE	HEAVY DUTY WHEEL CENTER
22MM	32MM	N/A	Flange Nut	450 lb-ft

8.5 ELECTRICAL

8.5.1 Power Shift Remote Control Programming

1. Apply a temporary 12 Volt positive (Key 1) and negative (Key 2) source to the receiver.
2. Locate the push button labeled "PROGRAM" on the receiver. Press and hold this button until the red LED next to the program button illuminates (approximately 3 seconds). The receiver is now in the remote program mode. Release the button. At this point all previously programmed remotes are erased from the receiver's memory.

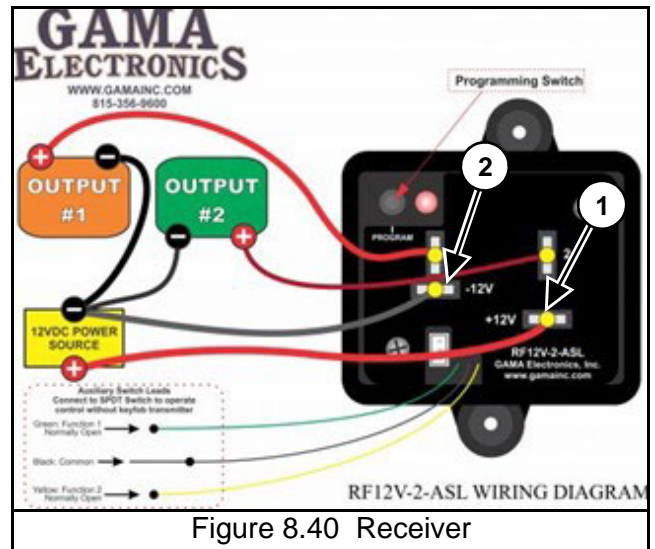

Figure 8.40 Receiver

3.
 - Single Remote:** Press and release either button on the remote once and verify that the red program LED extinguishes and blinks once.
 - Multiple Remotes:** For the first remote being programmed press and release either button once, then once on the second remote, once on the third remote, once on the fourth remote etc. The receiver will not respond to remotes that have been previously programmed. The first remote that is programmed determines the receiver's relay operating mode.
4. The receiver will return to normal mode if no remote buttons are pressed for 5-seconds. The red LED on the receiver will blink rapidly, then extinguish. The receiver is now in the normal mode of operation. Test remote by pressing either button. The red program LED on the receiver should stay on until the button on the remote is released.
5. This completes the programming instructions. The receiver will retain its programming even when power is removed.
6. Remove the temporary 12 Volt positive (Key 1) and negative (Key 2) source to the receiver.



Figure 8.41 Remote

8.5.1.1 Remote Troubleshooting

If your RF remote control system does not work out of the box, stops working or functions intermittently please take the following steps to resolve common issues. Please note that you must be 2-3 feet away from the receiver when operating the transmitter. Operating within 2-3 feet may result in no operation or intermittent operation.

1. Recharge your remote.
 - The remote can activate during shipping and drain the battery.
 - The remote can be charged using a micro USB cable and any standard USB outlet or charger. Plug the micro USB into the connector located on the bottom of the remote.

NOTE: When the transmitter is plugged into a USB outlet/charger the LED backlights will slowly fade on and then fade off while the unit is charging. Once the transmitter has reached a full charge, the LEDs will extinguish and remain off.

2. Check the voltage supply at the receiver.
 - The receiver is designed to function at 10VDC-15VDC. Voltage on the (+) and (-) terminals on the control should be within this range.
3. Reprogram the remote.
 - If the system is non-functional, try to reprogram the remote. The program may not have taken during the programming process, or the program button may have been pressed. If the program button is pressed the memory of the remote(s) programed to the receiver are erased.
4. Listen and look for functionality on the receiver.
 - The LED that is used for programming the system will illuminate when the receiver is activated. You will also hear a “click” when the internal relays engage. If you can see the LED illuminate and you hear the relay “click” the issue is most likely in the wiring or device being controlled.

8.5.2 Digital Scale Indicator

Refer to scale indicator (Item 1) manufacturer’s operators manual for maintenance.

NOTE: Some scale drift may occur after the scale is turned on but should level out within 10 to 15 minutes. Temperature changes may also cause some drifting.

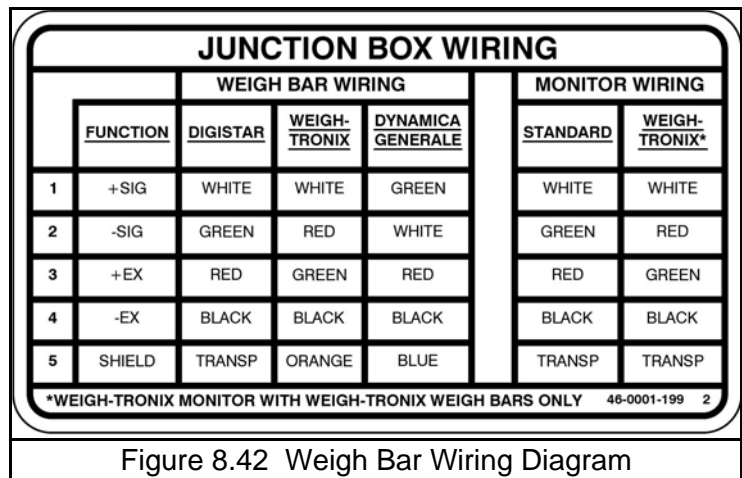

Figure 8.42 Weigh Bar Wiring Diagram

Scale Set Up Numbers

Digistar Monitors	
SET UP #	CALIBRATION #
127110	73818

Weigh-Tronix Monitors	
CONFIGURE #	CUSTOM #
98500	73800

8.6 BRAKES



Any corrosive materials (saltwater, fertilizers) are destructive to metals. To properly maintain the life of the brake system flushing with a high pressure water hose is recommended. After washing be sure to grease actuator bearings (slides) and oil all moving parts. At the end of season it is recommended that the brake drums be removed and cleaned inside. Flush wheel bearings being careful not to contaminate the brake system with lube. Readjust the brakes.

IMPORTANT

Before using any equipment equipped with brakes the operation of the brakes should be checked. Brake linings should be replaced before the rivets or support plates come in contact with the wheel drum. Perform all necessary maintenance before using equipment.

The PB-ADR-B manual should be used in conjunction with this manual.

Check and test the brakes before intensive use and every three months thereafter. Check the brake wear and the clearance between the brake linings and the drum visually. It is probable that the linings are worn when the brake travel has increased significantly. If the linings are worn to the minimum thickness, replace with new.

Check that the brakes are clean and clean them if necessary. Lubricate the brake camshaft bearings with grease zerks. To prevent grease from getting on the brake drum or linings, do not over grease.

8.7 WHEELS AND TIRES

8.7.1 Wheel Installation



These instructions are not complete. Read and follow all procedures in user's guide to wheels and rims by "The Maintenance Council" #T0410. If you have questions call Walther Eng. & Mfg. company inc. (937) 743-8125.

- Clean adjoining surfaces.
- Start nuts to bring wheel and brake drum flush to hub mounting surface.
- Avoid brake drum and/or wheel binding on hub.
- Install remaining wheel nuts. Torque to 50 ft-lbs, then re-torque to required full torque (See 8.4.2 Wheel Torque).
- Re-torque wheel nuts after 50-100 miles.
- Check wheel nut torque every 10,000 miles and re-torque as necessary.

8.7.2 Tire Inflation

TIRE SIZE	PSI
315/80R x 22.5	130

If tires are to operate for any length of time on roads or other hard surfaces and the draft load is not great, it is advisable to increase the pressure in the tire to the maximum recommendation in order to reduce the movement of the tread bars that causes excessive wiping action.

Inflation pressures should be checked at least every week. Recommended inflation pressures based on total load on tires should be used. For accurate inflation use a special low-pressure gauge with one-pound gradations. Gauges should be checked occasionally for accuracy. Always use sealing valve caps to prevent loss of air.

8.7.3 Implement Tires

Agricultural tires are designed to carry a specified load at a specified inflation pressure when mounted on a specified width rim. When these conditions are met, the deflection of the tire carcass is in the optimum range and maximum tire performance can be expected. If this combination of design factors is altered for any reason, tire performance will be reduced.

Tire Overload or Under Inflation

Tire overload or under inflation have the same effect of over-deflecting the tire. Under such conditions the tread on the tire will wear rapidly and unevenly, particularly in the shoulder area. Radial cracking in the upper sidewall area will be a problem. With under inflated drive tires in high torque applications sidewall buckles will develop leading to carcass breaks in the sidewall. While an under inflated drive tire may pull better in some soil conditions, this is not generally true and not worth the high risk of tire damage that such an operation invites.

Over Inflation

Over inflation results in an under-deflected tire carcass. The tread is more rounded, concentrates tread wear at the centerline area. Traction is reduced in high torque service because ground contact of the tread shoulder area is reduced and the harder carcass, with reduced flexing characteristics, does not work as efficiently. The tightly stretched overinflated carcass is more subject to weather checking and impact break damage.

Pressure Adjustments Required - Slow Speed Operation

Higher tire loads are approved for intermittent service operations at reduced speed. Under such conditions inflation pressure must be increased to reduce tire deflection and assure full tire service life. See 8.7.2 Tire Inflation for proper inflation.

Use of Proper Width Rims

If tires are mounted on rims of incorrect width, the following conditions can result:

- Use of a wider rim results in flattening of the tread face. This feature may improve traction in loose soil conditions. In hard soils, however, the flatter tread penetrates less effectively and tractive effort is reduced. Additional stresses concentrated in the shoulder area tend to increase the rate of shoulder tread wear. By spacing the tire beads farther apart the sidewalls are forced to flex in an area lower than normal and this can result in circumferential carcass breaks and/or separation.
- Use of a narrower rim brings potential mounting problems because the rim shield or flange cover molded into most drive tire designs tends to interfere with the seating of the tire beads on a narrow rim. Once mounted on a narrow rim, the tire shield applies undue pressure on the rim flange, with possible tire sidewall separation or premature rim failure at the heel radius. On a narrow rim the tread of the tire is rounded. As with the over-inflated tire tread wear will be concentrated in the center area of the tread and traction in the field will be reduced.

Roading Of Farm Implement Tires

- Tractor tires operate most of the time in field conditions where the lugs can penetrate the soil, and where all portions of the tread make contact with the ground. In operating on hard roads with low inflation pressure there is an undesirable distortion of the tire during which the tread bars squirm excessively while going under and coming out from under the load. On highly abrasive or hard surfaces, this action wipes off the rubber of the tread bars or lugs and wears them down prematurely and irregularly.
- Farm tractor and implement tires are designed for low-speed operations not exceeding 25 miles per hour. If tractors or implements are towed at high speeds on the highway high temperatures may develop under the tread bars and weaken the rubber material and cord fabric. There may be no visible evidence of damage at the time. Later a premature failure occurs which experience shows was started by the overheated condition that developed when the unit was towed at a high speed.

Care And Storage Of Tractor And Implement Tires

- All tires should be stored indoors in a cool, dark, dry area free from drafts. Both heat and light are sources of oxidation on the tire surfaces - a result of which is crazing and weather checking. Tires should never be stored on oily floors or otherwise in contact with solvents, oil or grease. Further, tires should not be stored in the same area with volatile solvents. Such solvents are readily absorbed by rubber and will damage and weaken it.
- Tires should be stored away from electric motors, generators, arc welders, etc. since these are active sources of ozone. Ozone attacks rubber - to cause crazing and weather checking.
- Unmounted tires should be stored vertically on tread. If stored for an extended period, tires should be rotated periodically to reduce stress concentrations in the area of ground contact. Tires should not be stored flat and "stove piped" as they will become squashed and distorted, making mounting on the rim difficult - particularly for tubeless tires.
- Inflated tires mounted on rims should be stored under conditions noted above, with inflation pressure reduced to 10 PSI.

8.8 STORING THE IMPLEMENT

LOCKOUT / TAGOUT the machine / mixer. (See 5.3 SHUTOFF & LOCKOUT POWER)

Extended Storage

Sometimes it may be necessary to store your Meyer mixer for an extended period of time. Below is a list of items to perform before storage.

- Fully empty the material from the mixer. (See 7.5 UNLOADING)
- Thoroughly clean the mixer inside and outside.
- Remove all material build-up.
- Lubricate the equipment. (See 8.2 LUBRICATION)
- Inspect all mixer components for wear or damage. Repair and replace components as necessary.
- Make appropriate adjustments to equipment. (See 8.3 ADJUSTMENTS)
- Place hydraulic hoses and 7-pin connector in the storage brackets (if equipped).
- Inspect the hitch and all welds on the equipment for wear and damage.
- Check for loose hardware, missing guards, or damaged parts.
- Check for damaged or missing safety signs (decals). Replace if necessary.
- Touch up all paint nicks and scratches to prevent rusting.
- Place the equipment in a dry protected shelter.
- Place the equipment flat on the ground.

8.9 RETURN THE IMPLEMENT TO SERVICE

After the Meyer mixer has been in storage, it is necessary to follow a list of items to return the equipment to service.

- Be sure all shields and guards are in place.
- Lubricate the equipment.
- Check tire pressure and that the lug nuts are tight.
- Connect to a tractor and operate equipment; verify all functions operate correctly.
- Check for leaks. Repair as needed.

8.10 MIXER TROUBLESHOOTING GUIDE

PROBLEM	POSSIBLE SOLUTIONS
Requiring High Horsepower	<ul style="list-style-type: none"> • Reduce load size. • Adjust hay stops to a less aggressive or neutral position. • The load size may need to be reduced until the unit is polished inside. • Modify the knife type, quantity, setting, or placement. • Shift mixer into “Low”.
Digital Scale Indicator	<ul style="list-style-type: none"> • Refer to scale manufacturer’s operator manual for operation and maintenance. • Some scale drift may occur after the scale is turned on but should level out within 10 to 15 minutes. • Temperature changes may also cause some drifting.
Planetary Reservoir Is Overflowing	<ul style="list-style-type: none"> • Check oil level when cold. • Clean breather. • Make sure hoses are not kinked or clogged. • Change oil.
Cooling Light Fault Indicated	<ul style="list-style-type: none"> • Check to make sure there is no debris preventing cooling fans from running. • Clean radiators. • Check electrical connections and wiring. • Check for faulty fan motors. Replace if necessary.



9.0 REPAIR PARTS

WARNING

Before servicing this equipment, ensure that all personnel, including family members are familiar with the equipment and the safety hazards that are present, along with the safety practices that should be observed while working in this equipment.

CAUTION

Inspect the axles, o-beams, spindles, tires, hitches and all safety shielding, safety signs and safety lighting regularly. These parts if not watched closely, could pose potential injury or death. If any part is found in need of repair, follow the SHUTOFF & LOCKOUT POWER recommendations and have qualified personnel repair immediately.

CAUTION

Shutoff and lockout power before adjusting, servicing, maintaining, or clearing an obstruction from this machine. Refer to section 5.3 SHUTOFF & LOCKOUT POWER.

IMPORTANT

It is important that everyone who works on this equipment is properly trained to help ensure that they are familiar with this procedure and that they follow the steps outlined above. This manual will remind you when to SHUTOFF & LOCKOUT POWER.

At times, parts on this implement will become worn or damaged. Performing repairs on this implement can pose a risk of injury including death. To reduce risk, the party that will be doing the repair should be very knowledgeable of the implement and the equipment that they will be using to do the repair.

- Review the repair so that a plan can be put together and the proper equipment can be used to repair this implement safely and correctly.
- Personal safety equipment may include items such as safety glasses, protective footwear, hearing protection, gloves, fire retardant clothes, etc.

WARNING

Crushing Hazard:
Do Not work under suspended or blocked parts



- The use of hoists and/or supports may be needed to handle heavy components.
- If the implement is being repaired in the field, make sure the parking brake of the tractor is engaged, the implement is on solid and level ground.
- Welding and torching should be done by properly trained individuals who have proven their skills.

IMPORTANT

Call the factory for any additional details you may need to perform the repair. Some parts may come with instruction sheets to assist in the repair. Instruction sheets may be provided with the parts order. Otherwise, if available, instruction sheets can be e-mailed or faxed for your convenience. Call Meyer Manufacturing Corporation toll free at 1-800-325-9103 or email parts@meyermfg.com.

NOTE: Be environmentally friendly and dispose of any waste materials properly. Recycle when appropriate.



LIGHTS

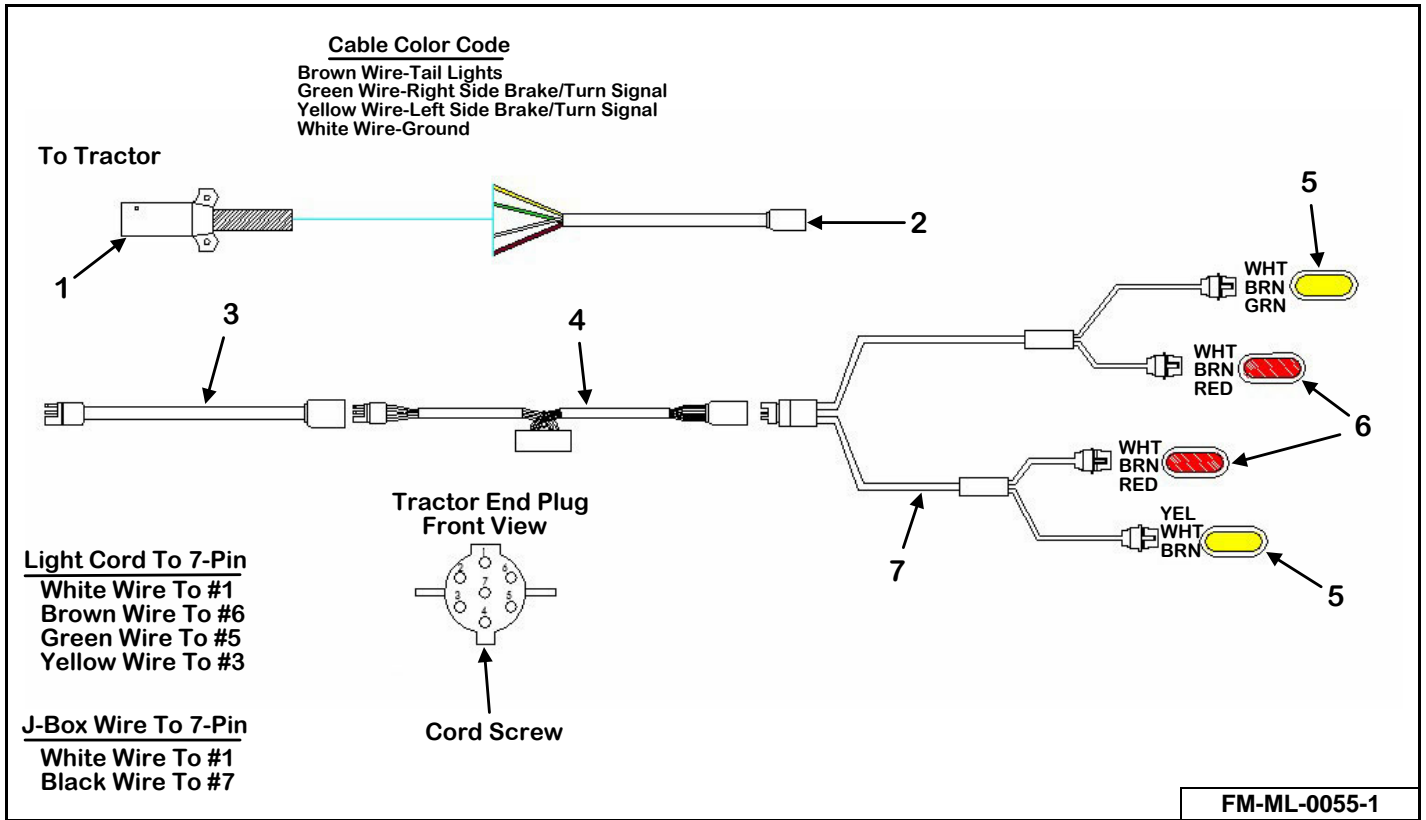

KEY	PART NUMBER	QTY	DESCRIPTION	MIXER MODEL
1	56-0005-4	1	7-Way Plug With Spring	1460
2	56-0306	1	Maxi-Seal Front Harness to 7-Pin	1460
3	56-0297	1	246" Maxi-Seal Harness Power Extension (Side/Quad Discharge)	1460
	56-0296	1	270" Maxi-Seal Harness Power Extension (Front Discharge)	1460
4	56-0284	1	Maxi-Seal Ag Module	1460
5	56-0081-AMP	2	6-1/2" Amber Clearance Light	1460
	56-0082	2	6-1/2" Oval Grommet	1460
6	56-0115-AMP	2	6-1/2" Red Clearance Light	1460
	56-0082	2	6-1/2" Oval Grommet	1460
7	56-0310	1	Maxi-Seal Rear Harness	1460

WEIGH BAR WIRING DIAGRAM

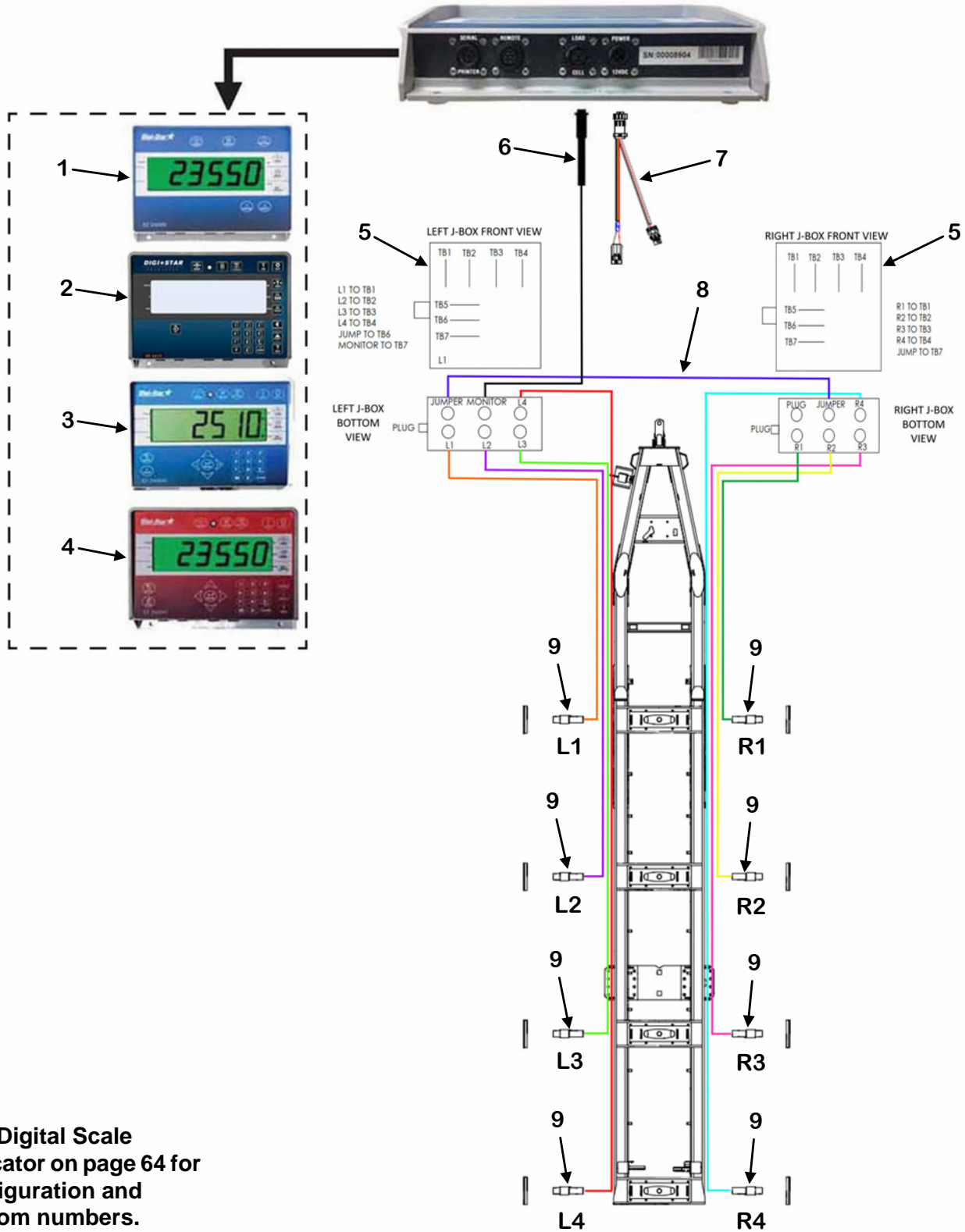

See Digital Scale Indicator on page 64 for configuration and custom numbers.

FM-F3-0001-1

KEY	PART NUMBER	QTY	DESCRIPTION	MIXER MODEL
1	58-0002-407120	1	EZ2500 Scale Indicator Monitor With Serial Port	1460
	58-0002-407094	1	EZ2500 Scale Indicator Monitor	1460
	58-0002-404516	1	EZ2400 Scale Indicator Monitor	1460
2	58-0002-281023	1	EZ2810 Scale Indicator Monitor	1460
3	58-0002-408944	1	EZ3400V Scale Indicator Monitor	1460
4	58-0002-406552	1	EZ3600V Scale Indicator Monitor	1460
5	58-0020	2	6 Point Mobil J-Box	1460
	58-0008	1	6 Point Mobil J-Box With Monitor Cable	1460
6	58-0029	1	Junction Box To Monitor Cable 30'	1460
7	See Page 76	1	Monitor Y-Harness	1460
8	58-0015-1	1	Junction Box To Junction Box Jumper Cable	1460
9	58-0034-WT	8	2.875" x 14" Load Cell	1460
NS	58-0002-410002	1	Pack RPM Sensor (No Extension Cable)	1460
NS	58-0002-408845	1	RPM Y-Alarm Cord	1460

POWER SHIFT ELECTRICAL SYSTEM WITH COOLERS

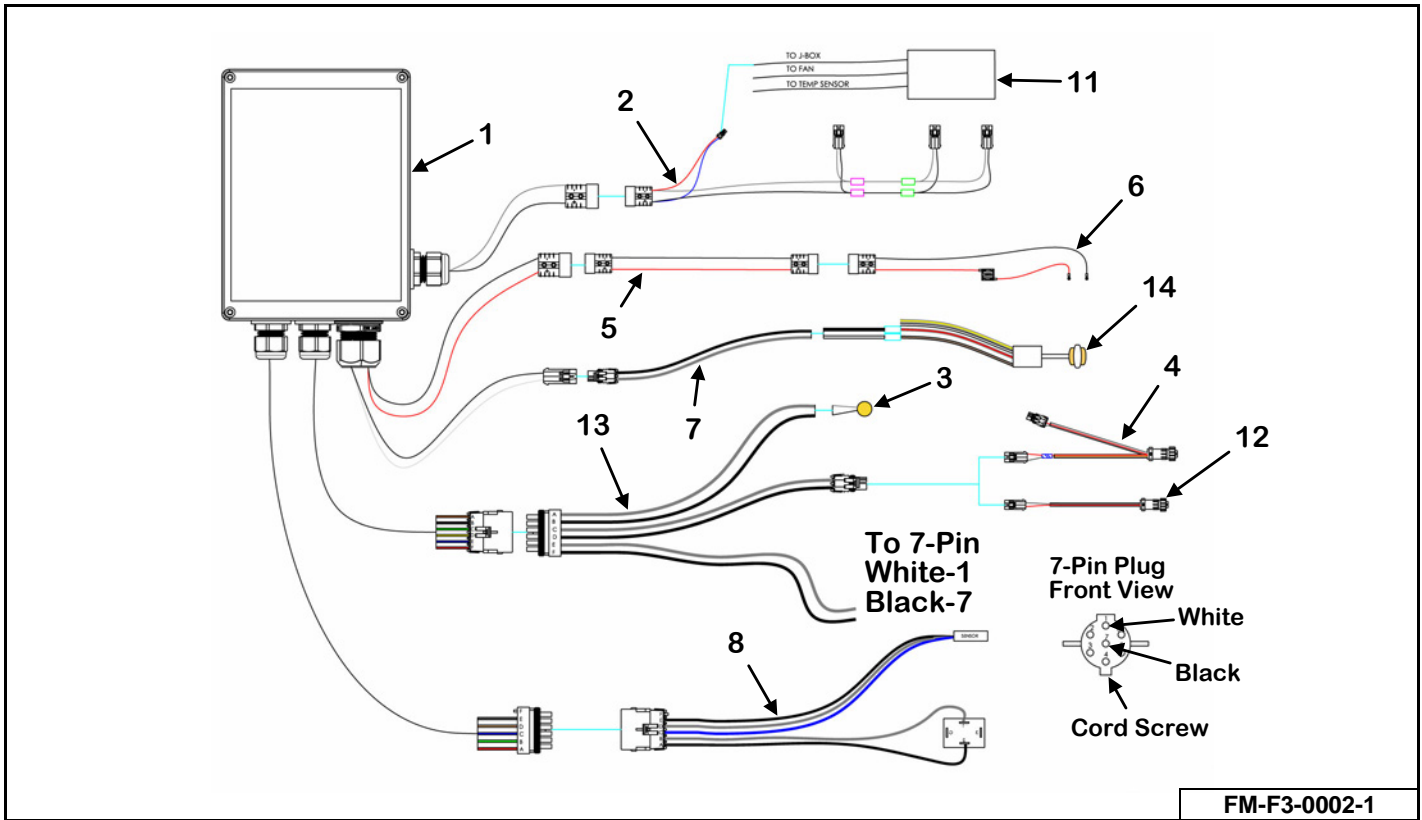

POWER SHIFT ELECTRICAL SYSTEM WITHOUT COOLERS

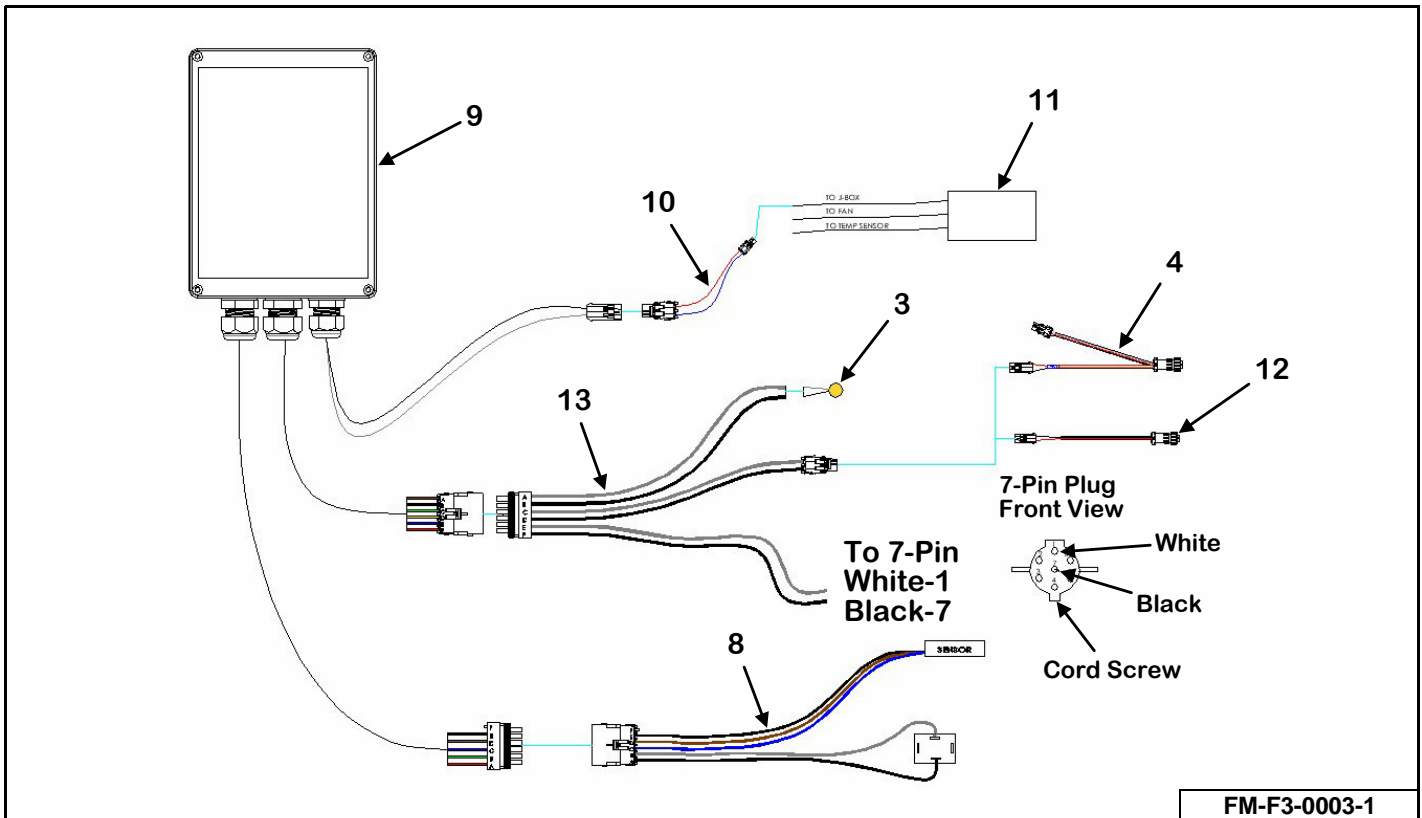

KEY	PART NUMBER	QTY	DESCRIPTION	MIXER MODEL
1	See Page 78	1	Junction Box Assembly	1460
2	56-0377	1	Fan Harness Assembly	1460
3	56-0111-BT	1	Amber Light	1460
4	56-0381	1	Monitor Y-Harness (Optional)	1460
5	56-0382	1	Battery Extension Harness	1460
6	56-0378	1	Battery Harness Assembly	1460
7	56-0390	1	Strobe Light Power Harness Assembly	1460
8	56-0375	1	Coil/Sensor Harness Assembly	1460
9	See Page 79	1	Junction Box Assembly	1460
10	56-0461	1	Fan Harness Assembly	1460
11	155-OC-TT07-1-1	1	Temperature Control Kit	1460
12	56-0459	1	No Rotational Counter Monitor Harness Assembly (Optional)	1460
13	56-0376	1	Light/Power Harness Assembly	1460
14	56-0391	1	Strobe Light Assembly	1460

POWER SHIFT JUNCTION BOX WITH COOLERS

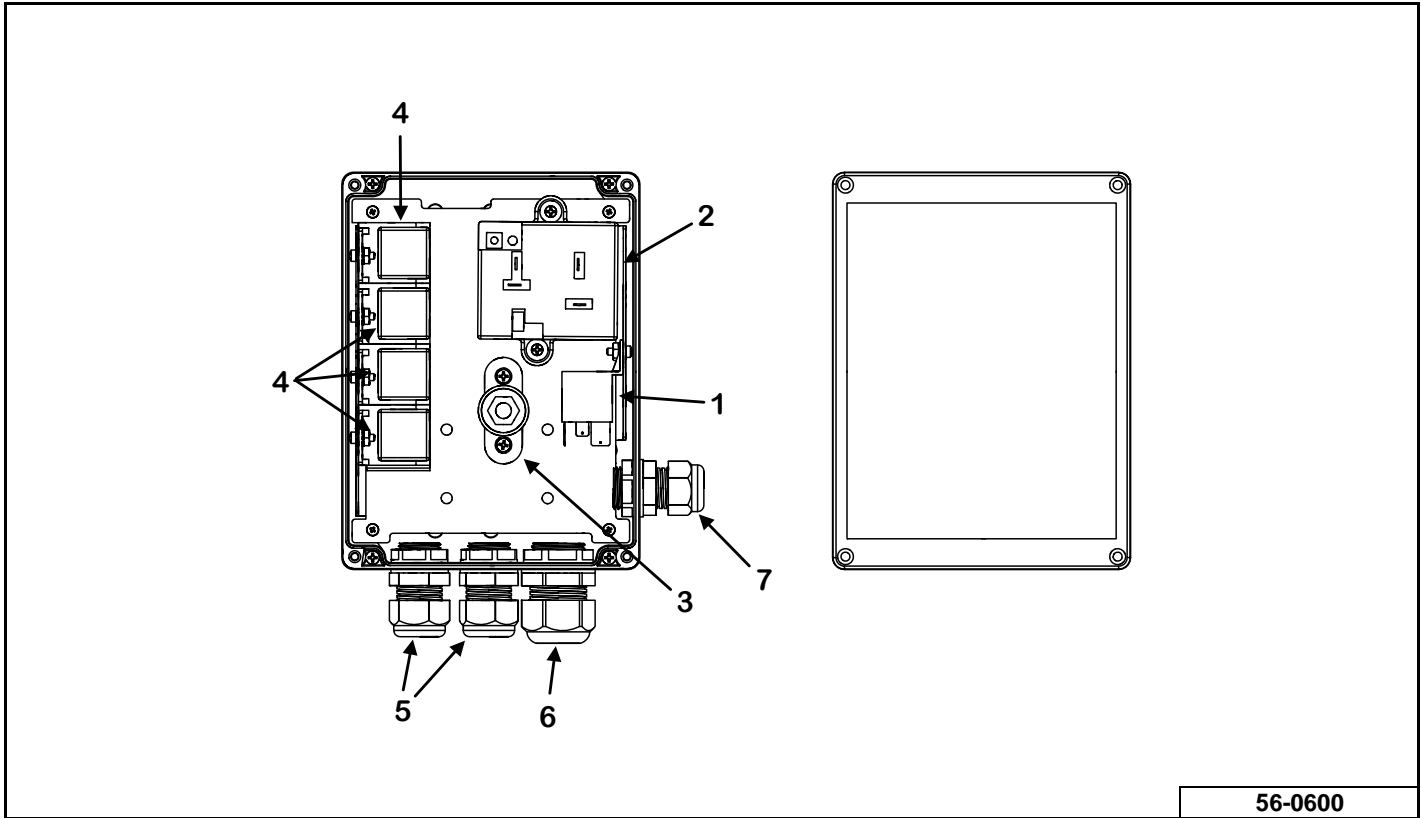

KEY	PART NUMBER	QTY	DESCRIPTION	MIXER MODEL
0	56-0600	1	Junction Box Assembly	1460
1	56-0200-3	1	70A Relay	1460
2	56-0350	1	Remote Control Receiver Assembly	1460
3	56-0433	1	Junction Block Stud	1460
4	56-0501-2	4	30/50A Relay	1460
5	156-CG-08-2	2	Cord Grip	1460
6	156-CG-12-1	1	Cord Grip	1460
7	156-CG-08-1	1	Cord Grip	1460

POWER SHIFT JUNCTION BOX WITHOUT COOLERS

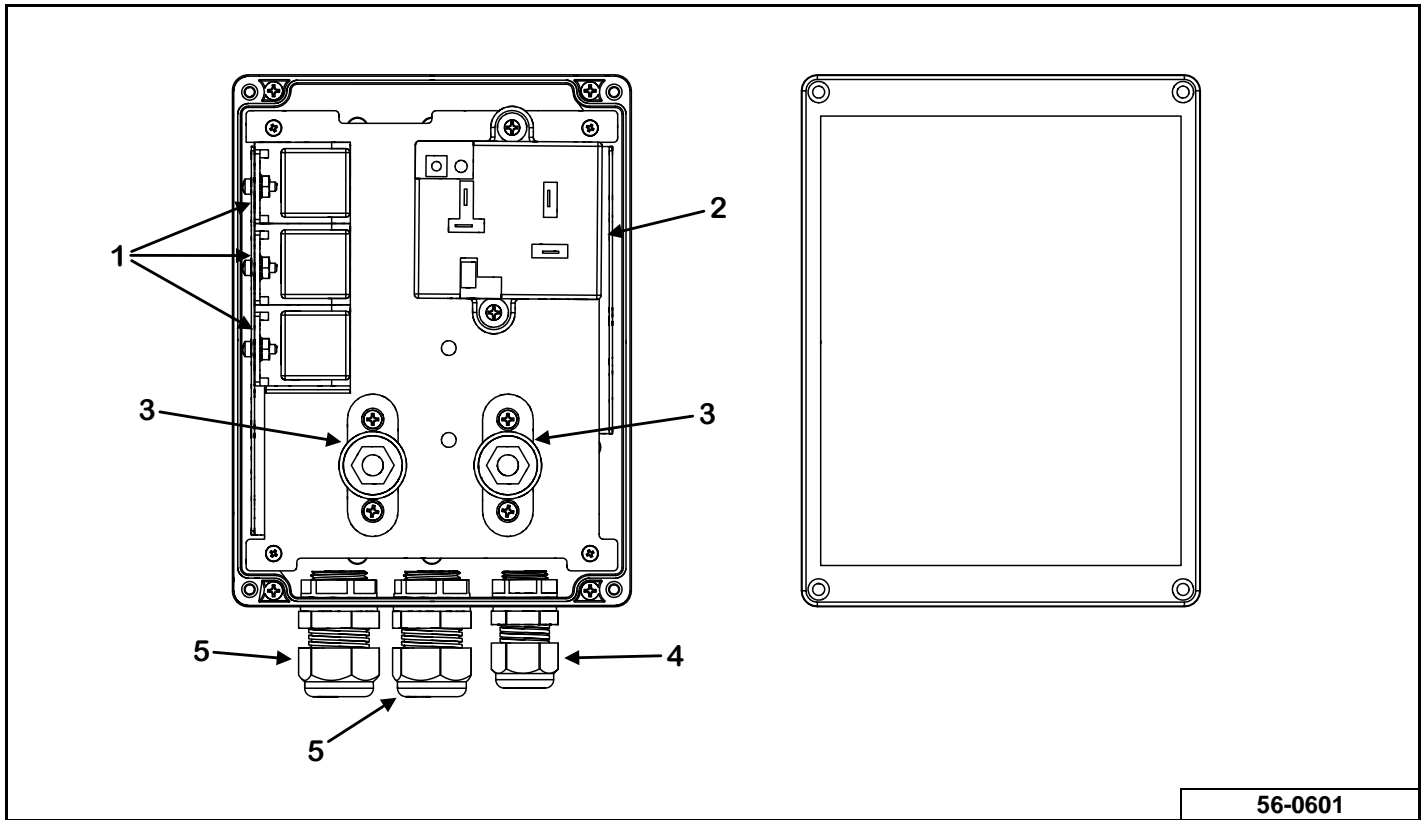

56-0601

KEY	PART NUMBER	QTY	DESCRIPTION	MIXER MODEL
0	56-0601	1	Junction Box Assembly	1460
1	56-0501-2	3	50A Relay	1460
2	56-0350	1	Remote Control Receiver Assembly	1460
3	56-0433	2	Junction Block Stud	1460
4	156-CG-06-1	1	Cord Grip	1460
5	156-CG-08-2	2	Cord Grip	1460

TRAILER

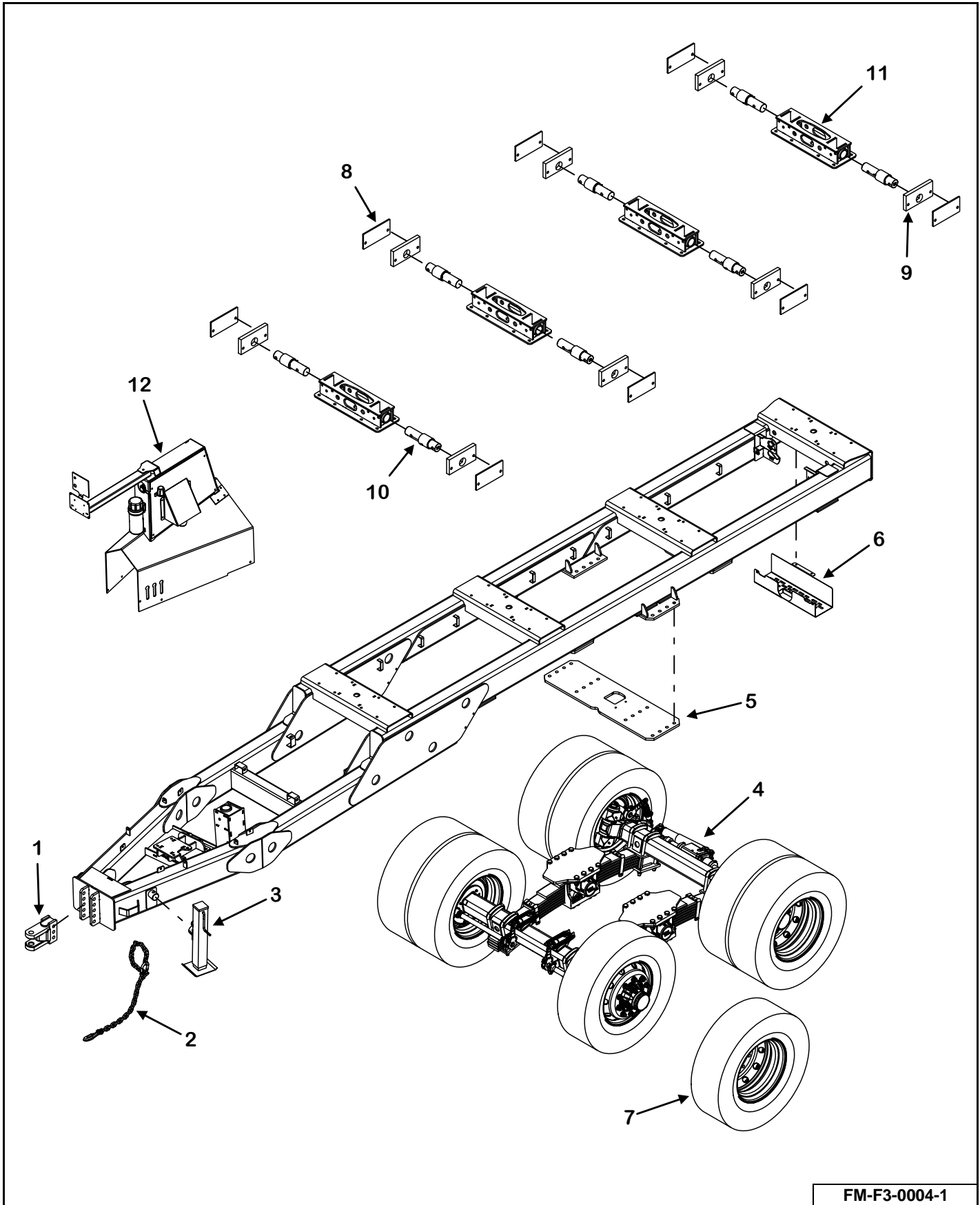

FM-F3-0004-1

KEY	PART NUMBER	QTY	DESCRIPTION	MIXER MODEL
1	75-4054-1	1	Clevis Weldment	1460
	75-2028	1	Bull Pull Hitch	1460
2	52-0052	1	Safety Chain, 60,000lb Capacity	1460
3	956-3804	1	10,000lb Jack	1460
4	See Page 84	1	Rigid Axle	1460
	See Page 86	1	Steerable Axle	1460
	See Page 88	1	Leaf Spring	1460
5	MN1-14-0012-1	1	Trailer Plate	1460
6	MN11-1-0008	1	Pump Mount Cover Weldment (Optional)	1460
7	Call 1-800-325-9103	8	Tire & Wheel	1460
8	MN1-14-0003-7	8	Scale Pod End Cap Plate	1460
9	MN1-14-0003-8	8	Scale Pod Body Mount Plate	1460
10	See Page 74	8	2.875" x 14" Load Cell	1460
11	MN1-14-0003	4	Scale Pod Weldment	1460
12	See Page 82	1	PTO Shroud	1460

PTO SHROUD

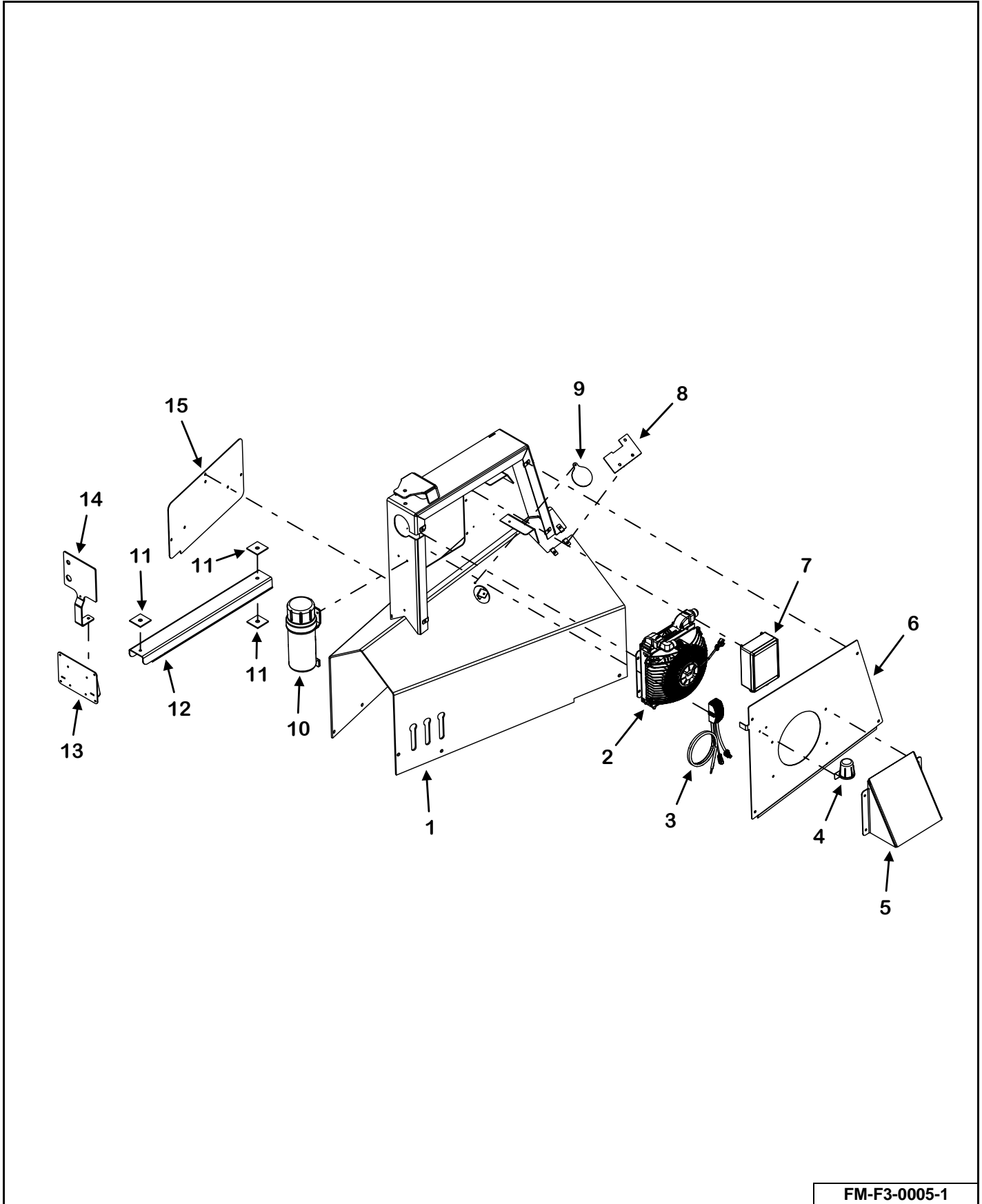

FM-F3-0005-1

KEY	PART NUMBER	QTY	DESCRIPTION	MIXER MODEL
1	MN11-1-0028-1	1	PTO Shroud Housing Weldment	1460
2	See Page	1	Power Shift Hydraulic Cooler	1460
3	See Page 76	1	Temperature Control Kit	1460
4	56-0009	1	Plug Holder	1460
5	MN11-1-0029	1	Cover	1460
6	MN11-1-0022	1	Heat Exchanger Housing Cover Plate	1460
	32-0302	4	Clip On Nut	1460
7	See Page 78	1	Junction Box With Planetary Coolers	1460
	See Page 79	1	Junction Box Without Planetary Coolers	1460
8	MN11-1-0002-4	1	Heat Exchanger Cover Plate	1460
	32-0302	3	Clip On Nut	1460
9	925-0608-1-3	1	Shield Cover	1460
10	33-0060	1	Operator Manual Canister	1460
11	M9-1-8-0004	3	Scale Arm Rubber Washer	1460
12	M9-1-4-0001	1	Load Display Pivot Arm	1460
13	M9-1-8-0002	1	Scale Indicator Mount Weldment	1460
14	MN11-1-0002-3	1	Indicator Light Bracket	1460
15	MN11-1-0002-1	1	PTO Shroud Cover Plate	1460
	32-0302	3	Clip On Nut	1460

RIGID AXLE

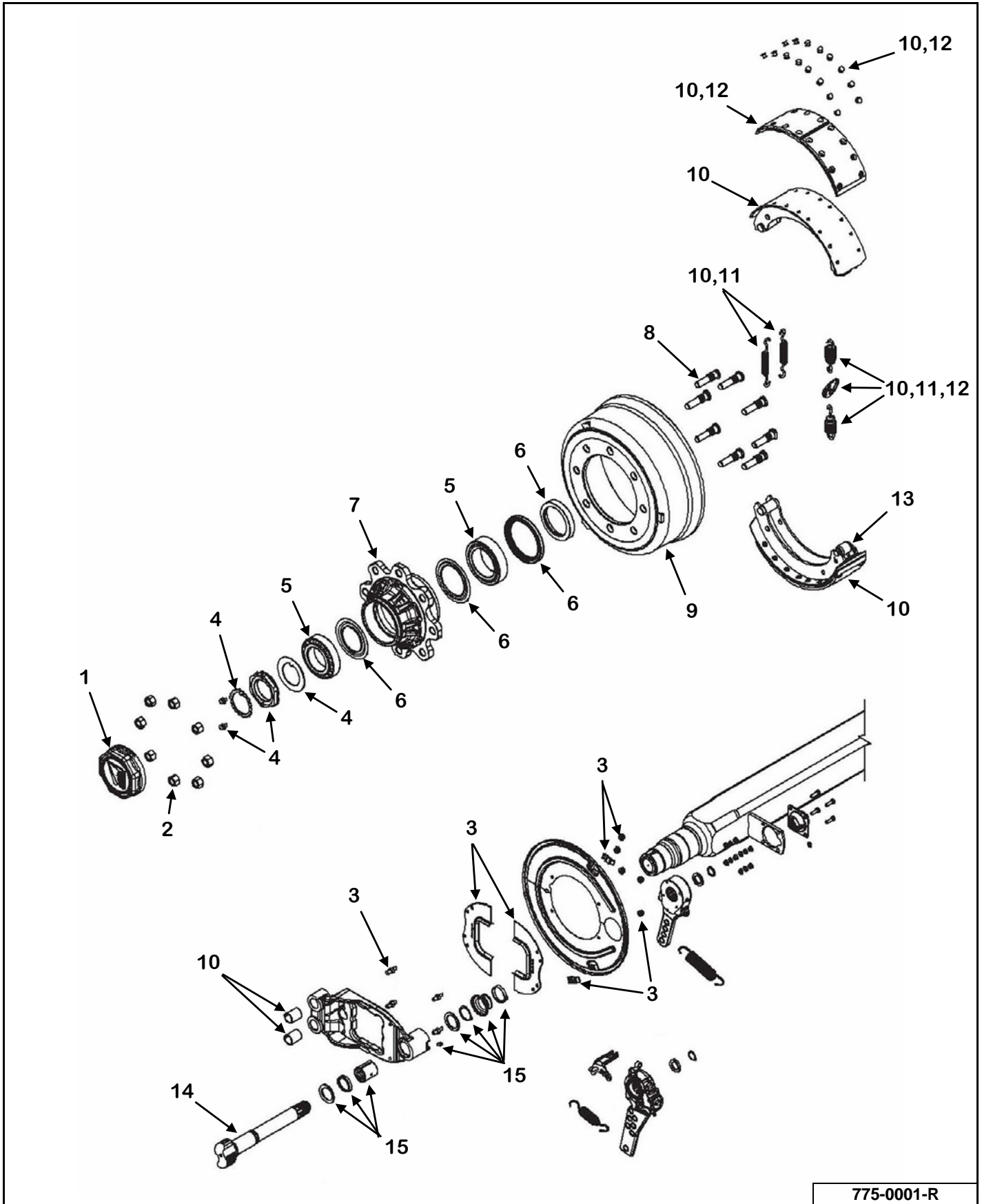

775-0001-R

KEY	PART NUMBER	QTY	DESCRIPTION
1	675-0002-5	2	Cap Kit
2	75-4500-1-1-2-1	AR	Lug Nut
3	675-0001-15	2	Protection Plate Kit
4	675-0002-6	2	Spindle Nut Kit
5	675-0002-7	2	Wheel Bearing Kit
6	675-0002-8	2	Race & Seal Kit
7	675-0002-9	2	Hub Casting
8	75-4500-1-1-1	2	Wheel Stud Kit (10 Wheel Studs Per Kit)
	75-4500-1-1-1-1	16	Wheel Stud
9	675-0001-8	2	Drum
10	675-0001-9	2	Brake Shoe Kit Contains Brake Shoes, Springs, Extender & Bushing
11	75-4505-1-3-K	2	Spring Kit Contains Brake Springs, Shoe Springs & Extender
	75-4505-1-2	2	Spring Extender
	75-4505-1-3	4	Brake Spring
	75-4505-1-18	4	Brake Shoe Spring
12	675-0001-10	2	Lining Kit
13	675-0001-11	1	Roll Brake Kit
14	775-0001-4-1	1	Right Cam Shaft
	775-0001-4-2	1	Left Cam Shaft
15	75-4505-1-CAM-K	1	Camshaft Kit (Does Not Include Cams)
	75-4505-1-6	4	Washer
	75-4505-1-7	4	Grease Seal
	75-4505-1-8	2	Bushing
	75-4500-1-3-21	2	Snap Ring
	75-4505-1-14	2	Rubber Cap
	75-4505-1-17	2	Grease Zerk

KEY	PART NUMBER	QTY	DESCRIPTION
1	675-0002-5	2	Cap Kit
2	75-4500-1-3-38	1	Shock Absorber
3	675-0002-14	1	Shock Support Kit
4	675-0002-6	2	Spindle Nut Kit
5	675-0002-7	2	Wheel Bearing Kit
6	675-0002-8	2	Race & Seal Kit
7	675-0002-9	2	Hub Casting
8	75-4500-1-1-1	2	Wheel Stud Kit
	75-4500-1-1-1-1	16	Wheel Stud
9	675-0001-8	2	Drum
10	675-0001-9	2	Brake Shoe Kit With Brake Shoes, Springs, Extenders & Bushing
	75-4505-1-3	4	Brake Spring
	75-4505-1-18	4	Brake Shoe Spring
	75-4505-1-19	4	Bushing
	75-4505-1-2	2	Spring Extender
11	75-4505-1-3-K	1	Spring Kit Includes Brake Springs, Shoe Springs & Extenders
	75-4505-1-2	2	Spring Extender
	75-4505-1-3	4	Brake Spring
	75-4505-1-18	4	Brake Shoe Spring
12	675-0001-10	1	Lining Kit
13	675-0002-12	1	Cam Kit
14	75-4505-1-CAM-K	1	Camshaft Kit (Does Not Include Cams)
	75-4505-1-6	4	Washer
	75-4505-1-7	4	Grease Seal
	75-4505-1-8	2	Bushing
	75-4505-1-3-21	2	Snap Ring
	75-4505-1-14	2	Rubber Cap
	75-4505-1-17	2	Grease Zerk
15	675-0002-3-1	2	Bushing Kit
16	675-0002-4	2	Pin & Cap Kit
17	75-4500-1-2-4	1	Stop Kit (Includes 4 Stop Bolts)
18	75-4505-1-38	2	Axial Ball Joint
19	675-0002-13	2	Steering Joint Kit
20	75-4505-1-42	1	Hydraulic Cylinder
	675-0003-4-1	1	Seal Kit
21	75-4500-1-1-2-1	AR	Lug Nut
22	675-0001-11	2	Roll Brake Kit
23	775-0001-5-1	2	Protection Plate

LEAF SPRING

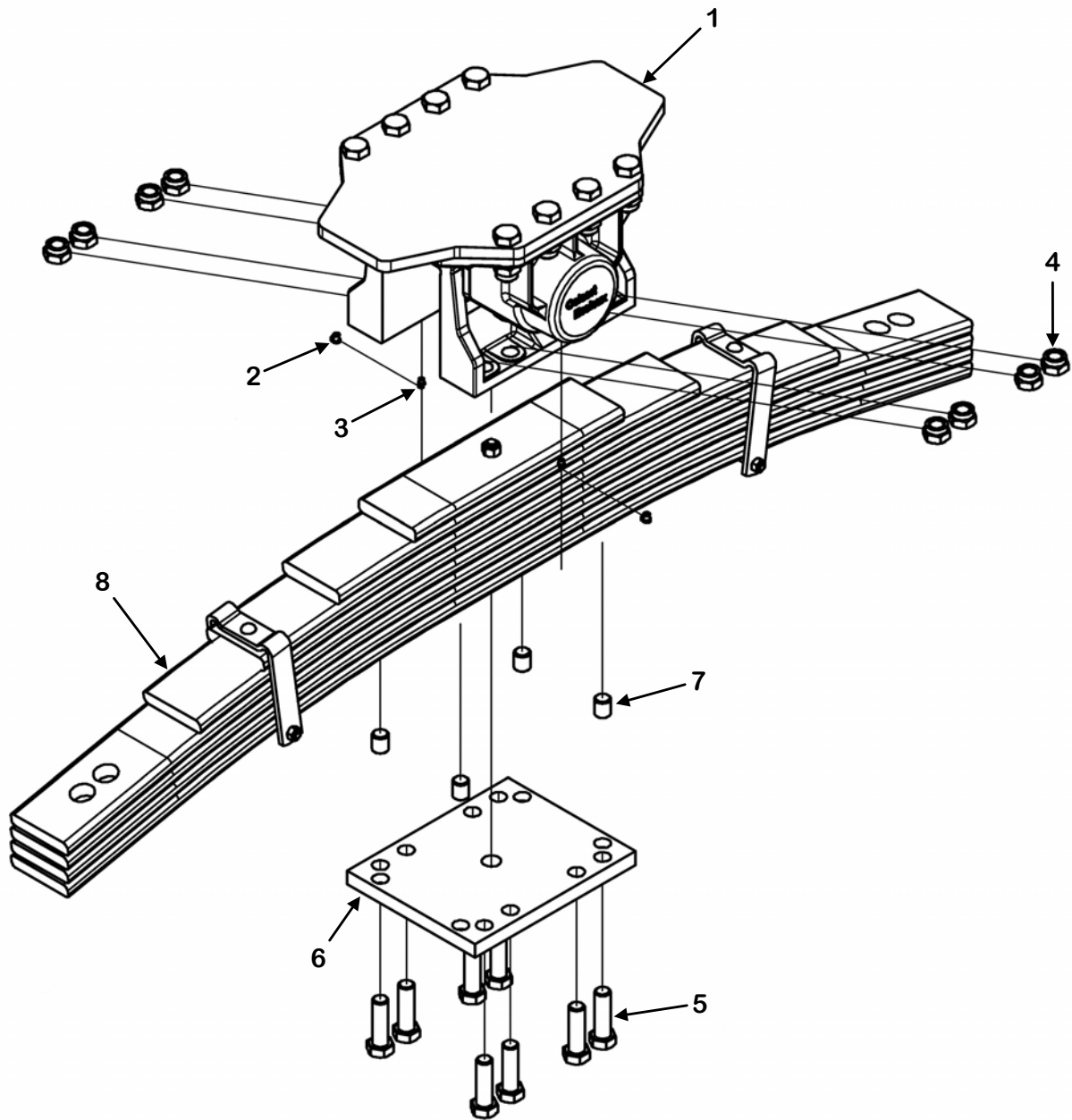

775-0001-7

KEY	PART NUMBER	QTY	DESCRIPTION
0	775-0001-7	2	Leaf Spring Kit
1	775-0001-7-2	2	Support Bogie
2	775-0001-7-3	2	Cap For Grease Zerk
3	75-4505-1-17	2	Straight Grease Zerk
4	775-0001-7-4	16	Self Locking Nut
5	775-0001-7-5	16	Counter Plate Lower Bogie
6	775-0001-7-6	2	Screw
7	775-0001-7-7	8	Contact Pin
8	775-0001-7-1	2	Leaf Spring Pack

LOCK & STEER HYDRAULIC SYSTEM

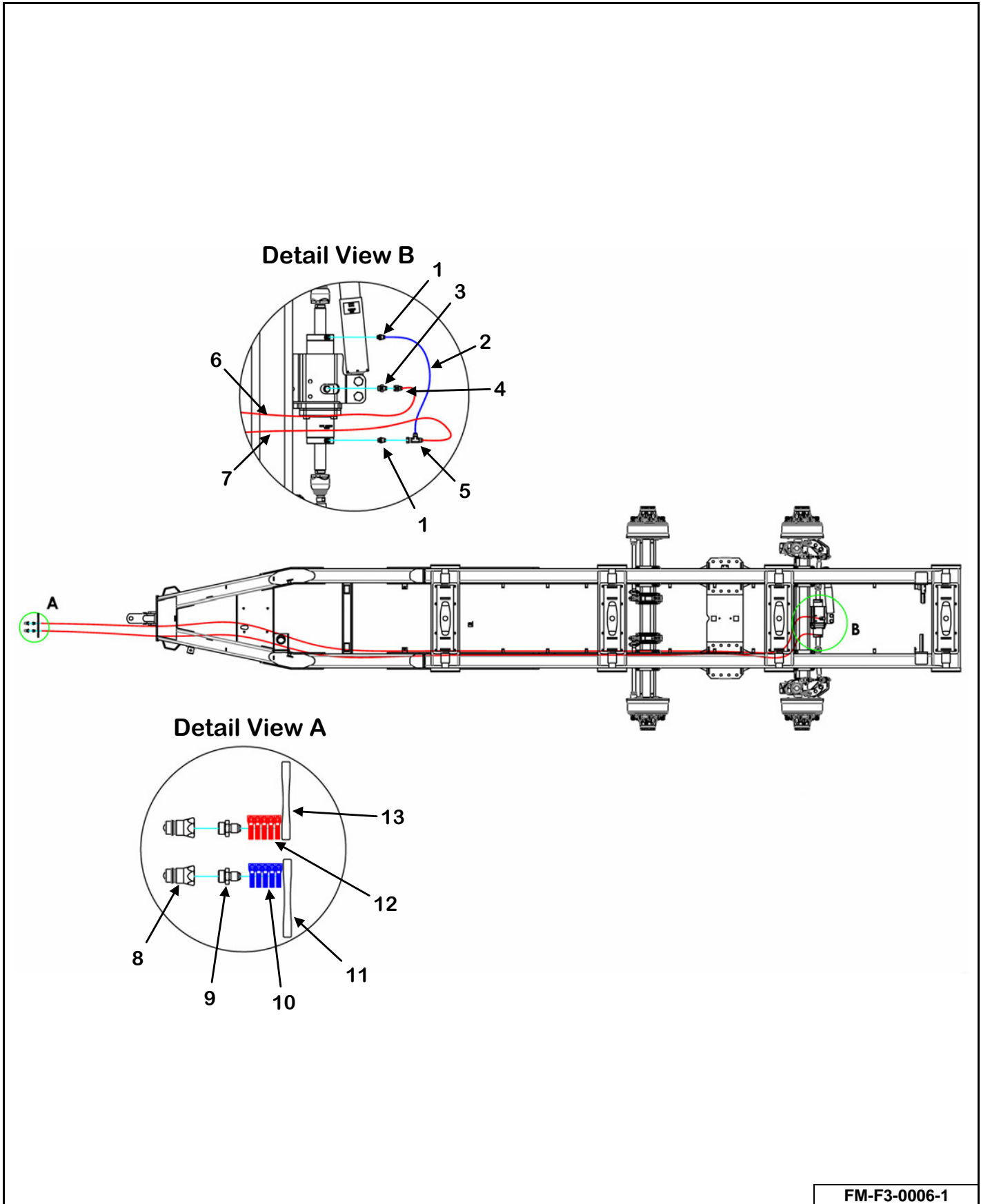

KEY	PART NUMBER	QTY	DESCRIPTION
1	155-7002-06-04	2	Straight Adapter
2	155-04R17-15-1	1	1/4" x 15" Hose Assembly
3	155-JB06-06	1	Straight Adapter
4	155-2406-06-06	1	Straight Coupler
5	155-6602-06-06-06	1	Tee
6	155-04R17-394-1	1	1/4" x 394" Hose Assembly (Front Discharge)
	155-04R17-360-1	1	1/4" x 360" Hose Assembly (Side/Quad Discharge)
7	155-04R17-388-1	1	1/4" x 388" Hose Assembly (Front Discharge)
	155-04R17-354-1	1	1/4" x 354" Hose Assembly (Side/Quad Discharge)
8	155-8010-15	2	1/2" Male Tip
9	155-6400-6-8	2	Straight Adapter
10	32-0054	5	Blue Cable Tie (Front Discharge)
	32-0054	4	Blue Cable Tie (Side/Quad Discharge)
11	46-0001-111	1	Steer Unlock Hose Decal
12	32-0053	5	Red Cable Tie (Front Discharge)
	32-0053	4	Red Cable Tie (Side/Quad Discharge)
13	46-0001-110	5	Steer Lock Hose Decal

HYDRAULIC BRAKE SYSTEM

Manifold Adapters Detail View D

Left View

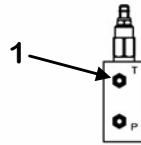

Bottom View

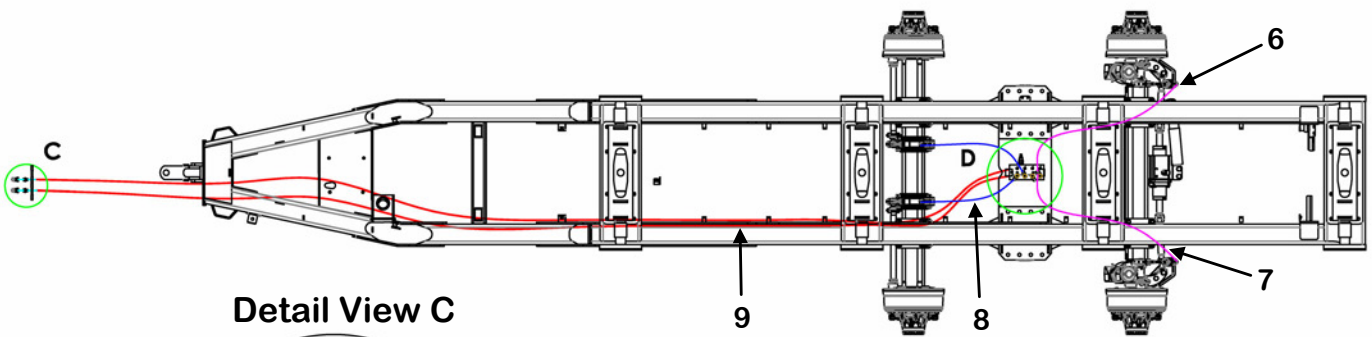
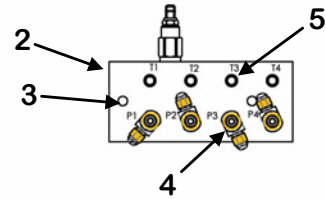

Detail View C

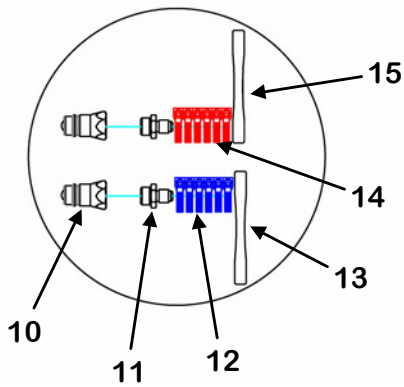

FM-F3-0007-1

KEY	PART NUMBER	QTY	DESCRIPTION
1	155-2404-06-04	2	Straight Adapter
2	57-0046	1	Manifold Block Assembly With Relief Valve
3	851-3118-3Z	2	5/16"-18 x 3" Hex Cap Screw
	815-3118-Z	2	5/16"-18 Nylon Lock Nut
4	155-2501-06-04	4	90° Fitting
5	55-0167	4	1/4" Square Plug
6	155-7202-06-06	4	90° Fitting
7	155-04R17-82-1	2	1/4" x 82" Hose Assembly
8	155-04R17-36-1	2	1/4" x 36" Hose Assembly
9	155-04R17-330-1	2	1/4" x 330" Hose Assembly (Front Discharge)
	155-04R17-296-1	2	1/4" x 296" Hose Assembly (Side/Quad Discharge)
10	155-8010-15	2	1/2" Male Tip
11	155-6400-6-8	2	Straight Adapter
12	32-0054	6	Blue Cable Tie (Front Discharge)
	32-0054	5	Blue Cable Tie (Side/Quad Discharge)
13	46-0001-113	1	Brake Return Hose Decal
14	32-0053	6	Red Cable Tie (Front Discharge)
	32-0053	5	Red Cable Tie (Side/Quad Discharge)
15	46-0001-112	1	Brake On Hose Decal

MIXER

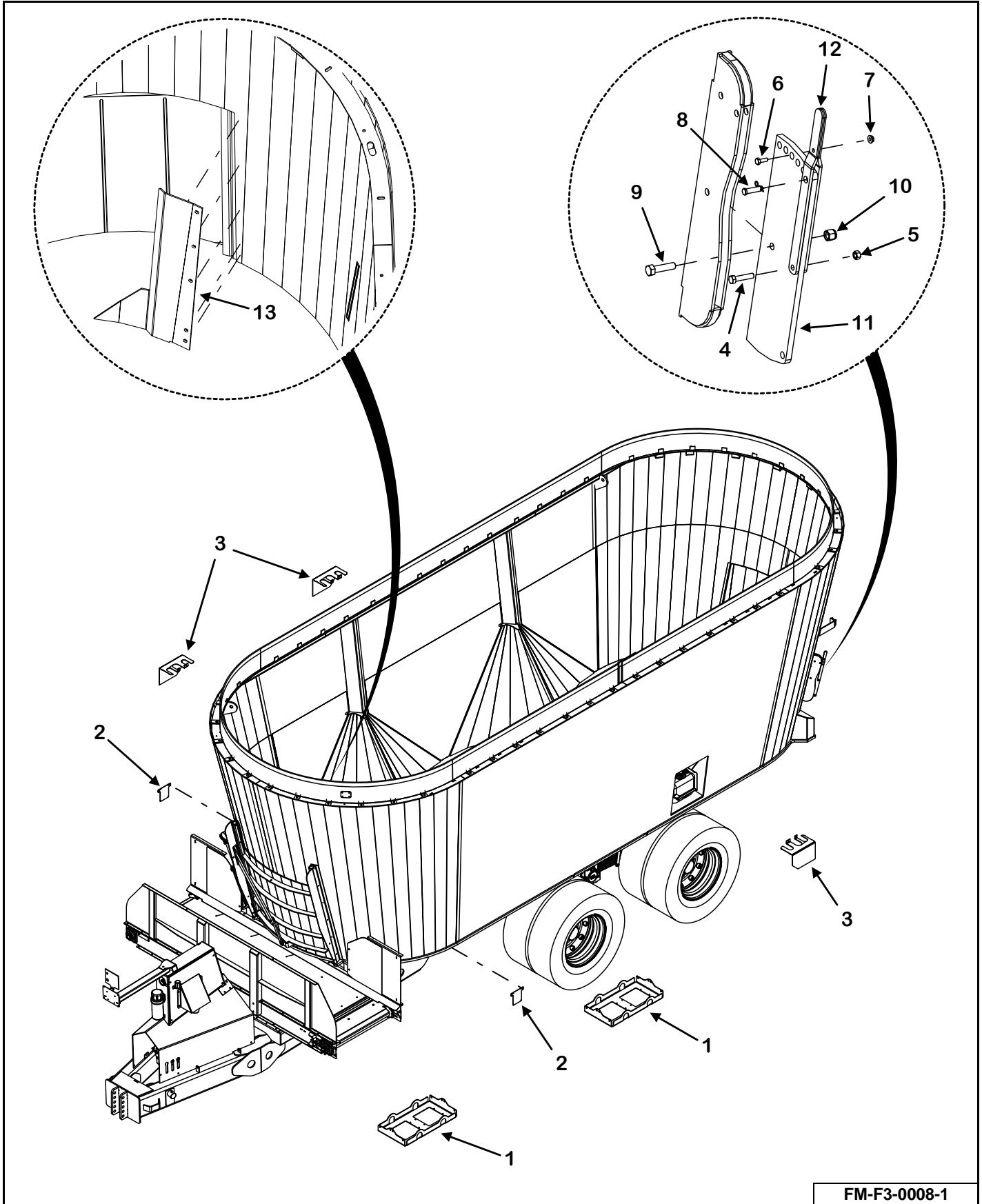

FM-F3-0008-1

KEY	PART NUMBER	QTY	DESCRIPTION	MIXER MODEL
1	MN11-1-0009-1	2	Cooler Mount Plate (Optional)	1460
2	MN2-12-0001-21	2	J-Box Mount Plate	1460
3	MN2-14-0007	3	Planetary Oil Tank Cover Weldment	1460
4	851-3816-1.75Z	2	3/8"-16 x 1-3/4" Machine Bolt	1460
5	815-3816-Z	2	3/8"-16 Nylon Insert Lock Nut	1460
6	851-2520-.75Z	2	1/4"-20 x 3/4" Machine Bolt	1460
7	810-2520-Z	2	1/4" Spin Lock Nut	1460
8	32-0042	2	1/2" x 1-1/2" Clevis Pin With Clip	1460
9	851-5013-2Z	2	1/2"-13 x 2" Machine Bolt	1460
10	815-5013-Z	2	1/2"-13 Nylon Lock Nut	1460
11	M7-1-8-0002	2	Hay Stop	1460
12	M7-1-8-0003	4	Hay Stop Handle	1460
13	MN6-14-0002	1	Front/Rear Door Deflector	1460
	803-3816-1.25Z	5	3/8"-16 x 1-1/4" Flat Head Socket Cap Screw	1460
	815-3816-Z	5	3/8"-16 Nylon Insert Lock Nut	1460

FRONT FLAT & INCLINE BASE BELT CONVEYOR

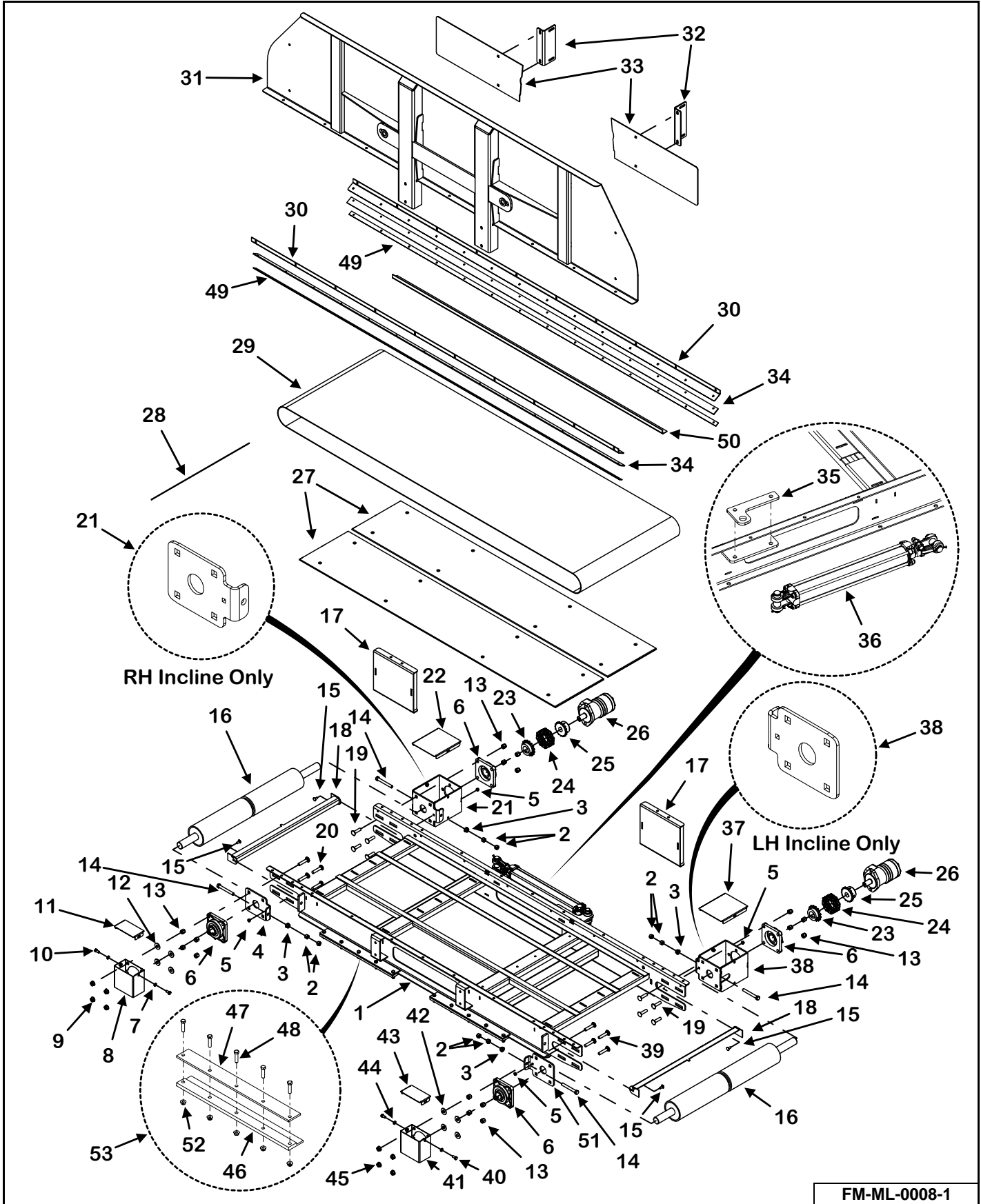

FM-ML-0008-1

KEY	PART NUMBER	QTY	DESCRIPTION	MIXER MODEL
0	VAL-FDB-36-2MI	1	2 Motor Front Discharge Flat Belt Conveyor (Incline Ready)	1460
1	M3-1-10-0017-1	1	Incline Base Conveyor Weldment	1460
2	813-5013-Z	8	1/2"-13 Nut	1460
3	810-5013-Z	4	1/2" Spin Lock Nut	1460
4	M3-1-5-0044-1	2	Front Conveyor Bearing Mount	1460
	See Page 150	1	Bearing Mount Weldment (RH Power Magnet)	1460
5	814-3118-Z	4	5/16"-18 Indented Lock Nut	1460
6	14-0070	4	1-1/2" 4-Bolt Bearing Narrow Inner Race	1460
7	822-0038-Z	2	3/8" Split Lock Washer (No Incline, LH Incline)	1460
8	M3-1-8-0047	1	Shaft Cover Weldment (No Incline, LH Incline)	1460
9	810-5013-Z	4	1/2" Spin Lock Nut (No Incline, LH Incline)	1460
10	851-3816-.75Z	2	3/8"-16 x 3/4" Machine Bolt (No Incline, LH Incline)	1460
11	M3-1-8-0048	1	Shaft Cover Plate (No Incline, LH Incline)	1460
12	805-0050-Z	4	1/2" Flat Washer (No Incline, LH Incline)	1460
13	815-5013-Z	16	1/2"-13 Nylon Lock Nut	1460
14	830-5013-4Z	4	1/2"-13 x 4" Tap Bolt Full Threaded	1460
15	850-3118-.75Z	4	5/16"-18 x 3/4" Carriage Bolt	1460
16	23-0269	2	Drive Pulley Urethane Lagged	1460
17	M3-1-10-0022	2	Conveyor Shield Weldment (Front Flat Sliding Conveyor Only)	1460
18	M3-1-10-0023	2	Conveyor Pulley Scraper	1460
19	850-5013-1.75Z	8	1/2"-13 x 1-3/4" Carriage Bolt	1460
20	850-5013-2.25Z	4	1/2"-13 x 2-1/4" Carriage Bolt	1460
21	M3-1-8-0046	1	Front Conveyor Motor Mount Weldment (No Incline, LH Incline)	1460
	See Page 150	1	Motor Mount Weldment (RH Power Magnet)	1460
22	M3-1-8-0045	1	Chain Coupler Cover Plate	1460
	851-3816-.75Z	2	3/8"-16 x 3/4" Machine Bolt	1460
	822-0038-Z	2	3/8" Split Lock Washer	1460
23	110-50B16-1.50-1	2	Coupler Sprocket	1460
	35-0006	2	Key	1460
24	37-0013-2	2	Coupler Chain	1460
25	37-0013-1	2	Coupler Sprocket	1460
26	See Page 100	2	12.25 Cubic Inch 2-Bolt Motor	1460
	135-2525-1.25-1	2	Key	1460
27	M3-1-10-0019	2	Front Belt Discharge Conveyor Floor	1460
	803-3118-1Z	16	5/16"-18 x 1" Flat Socket Head Cap Screw	1460
	805-0031-Z	16	5/16" Flat Washer	1460
	815-3118-Z	16	5/16"-18 Nylon Insert Lock Nut	1460

KEY	PART NUMBER	QTY	DESCRIPTION	MIXER MODEL
28	49-0156-6-AS	1	Conveyor Belt Lacing Pin Kit	1460
29	49-0156-MB	1	Front Conveyor Mini Bite Belt	1460
30	M3-1-10-0017-7	2	Front Conveyor Skirt Bracket	1460
31	M3-1-10-0018	1	Base Conveyor Front Panel Weldment	1460
32	M3-1-8-0028	2	Front Conveyor Shield Mounting Bracket	1460
33	M3-1-10-0009	1	Front Conveyor Shield, Left (Flat Sliding Conveyors)	1460
	M3-1-10-0008	1	Front Conveyor Shield, Right (Flat Sliding Conveyors)	1460
34	49-0336	2	Base Conveyor Skirting	1460
35	M3-1-8-0027	1	Front Conveyor Cylinder Mount (Front Flat Sliding Conveyor Only)	1460
	851-5013-1.75Z	2	1/2"-13 x 1-3/4" Machine Bolt (Front Flat Sliding Conveyor Only)	1460
	810-5013-Z	2	1/2" Spin Lock Nut (Front Flat Sliding Conveyor Only)	1460
36	See Page 100	1	Front Flat Belt Conveyor Hydraulic Schematic	1460
37	M3-1-8-0045	1	Chain Coupler Cover Plate	1460
	851-3816-.75Z	2	3/8"-16 x 3/4" Machine Bolt	1460
	822-0038-Z	2	3/8" Split Lock Washer	1460
38	M3-1-8-0046	1	Front Conveyor Motor Mount Weldment	1460
	See Page 150	1	Motor Mount Weldment (LH Power Magnet)	1460
39	850-5013-2.25Z	4	1/2"-13 x 2-1/4" Carriage Bolt	1460
40	851-3816-.75Z	2	3/8"-16 x 3/4" Machine Bolt	1460
41	M3-1-8-0047	1	Shaft Cover Weldment	1460
42	805-0050-Z	4	1/2" Flat Washer	1460
43	M3-1-8-0048	1	Shaft Cover Plate	1460
44	822-0038-Z	2	3/8" Split Lock Washer	1460
45	810-5013-Z	4	1/2" Spin Lock Nut	1460
46	M3-1-8-0053	4	Conveyor Bottom Slide (Flat Sliding Conveyor Only)	1460
47	M3-1-8-0052	4	Conveyor Slide Cap (Flat Sliding Conveyor Only)	1460
48	851-3816-1.5Z	20	3/8"-16 x 1-1/2" Hex Cap Screw	1460
49	M3-1-10-0017-8	2	Front Conveyor Skirt Backer	1460
50	M3-1-10-0017-4	1	Floor Seal	1460
51	M3-1-5-0044-1	1	Front Conveyor Bearing Mount	1460
	See Page 134	1	Bearing Mount Weldment (LH Power Magnet)	1460
52	810-3816-Z	20	3/8"-16 Spin Lock Nut	1460
53	M3-1-8-0053-AS	4	Conveyor Bottom Slide With Cap & Hardware	1460

FRONT FLAT BELT CONVEYOR HYDRAULIC SCHEMATIC

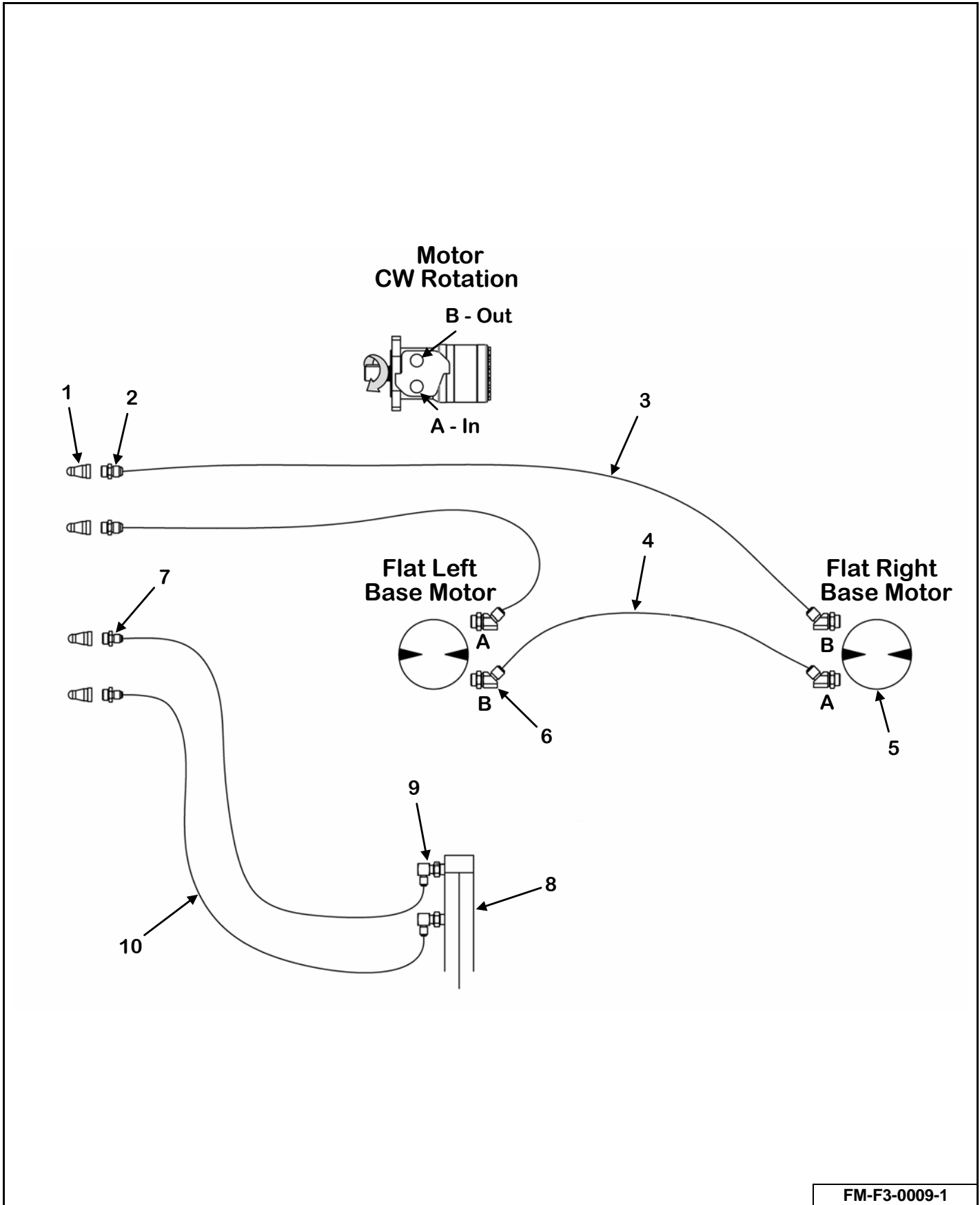

KEY	PART NUMBER	QTY	DESCRIPTION	MIXER MODEL
1	155-8010-15	4	#8 ORB Male Tip 1/2" Body Size	1460
2	155-6400-8-8	2	#8 JIC Male, #8 ORB Male Straight Connector	1460
3	155-08R17-234-1	2	1/2" x 234" Hose Assembly	1460
4	155-08R17-138-1	1	1/2" x 138" Hose Assembly	1460
5	155-BMRSY-12.25-1	2	Hydreco 12.25 Cubic Inch 2-Bolt Motor	1460
6	155-6802-8-10	4	#8 JIC Male, #10 ORB Male Adjustable 45°	1460
7	155-6400-6-8	2	#6 JIC Male, #8 ORB Male Straight Connector	1460
8	155-2-16-1.125-2	1	2" x 16" x 1-1/8" Hydraulic Cylinder, Modified Port	1460
	155-2-1.125-1-DSK	1	Cylinder Seal Kit	1460
9	155-6801-6-8	2	#6 JIC Male, #8 ORB Male Adjustable 90°	1460
10	155-04R17-212-2	2	1/4" x 212" Hose Assembly	1460

FRONT FLAT CHAIN CONVEYOR ASSEMBLY

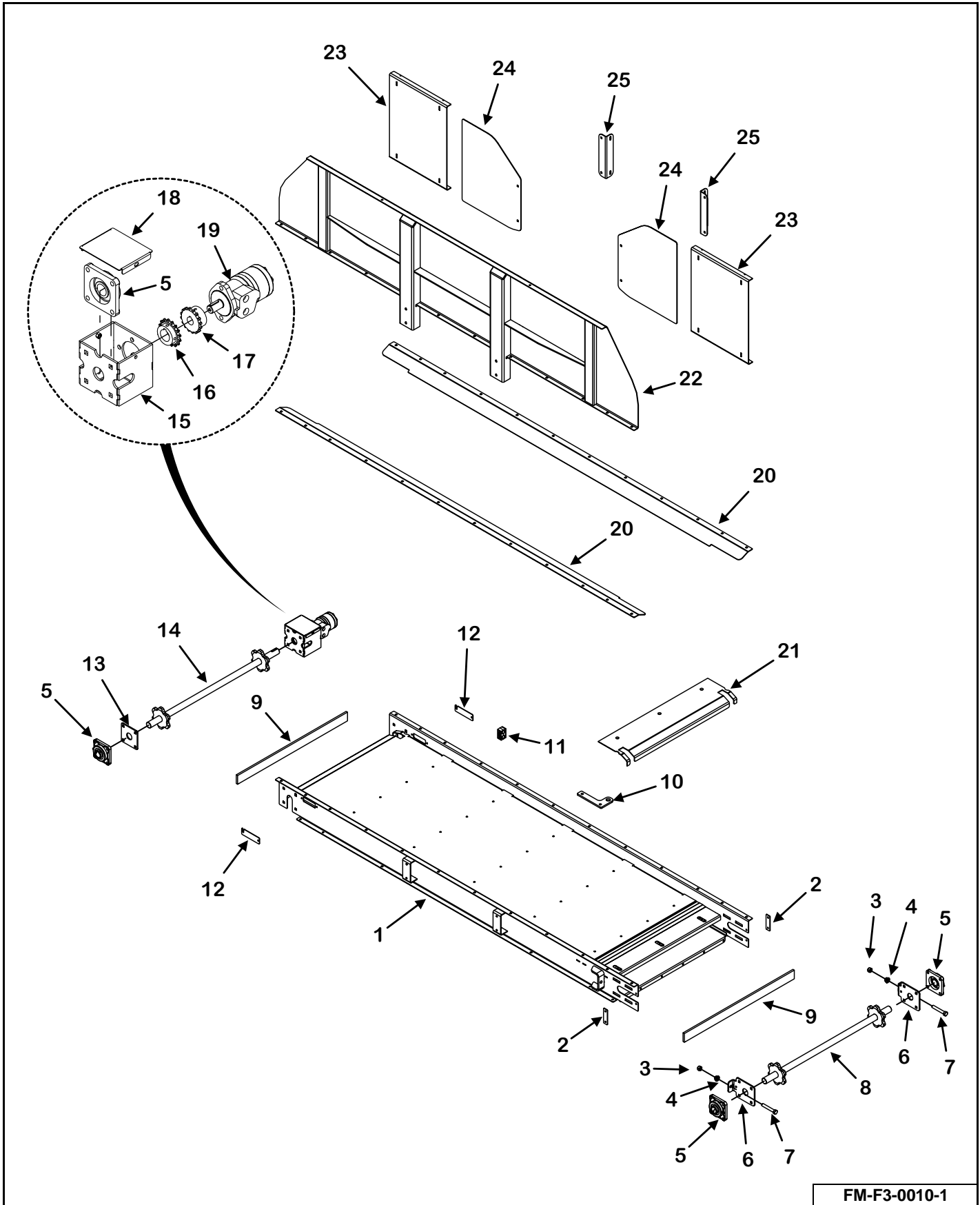

FM-F3-0010-1

KEY	PART NUMBER	QTY	DESCRIPTION	MIXER MODEL
1	MN3-14-0002	1	Front Conveyor Weldment	1460
2	MN3-14-0001-1	2	Cap	1460
3	813-6311-Z	2	5/8"-11 Hex Nut	1460
4	810-6311-Z	2	5/8"-11 Spin Lock Nut	1460
5	14-0070	4	1-1/2" 4-Bolt Bearing	1460
6	MN3-14-0001-4	2	Conveyor Bearing Mount	1460
7	830-6311-4Z	2	5/8"-11 x 4" Hex Tap Bolt	1460
8	23-0255	1	Conveyor Idler Shaft Weldment	1460
9	49-0181	2	Front Chain Conveyor Belt	1460
10	M3-1-8-0027	1	Front Conveyor Cylinder Mount	1460
11	155-2SCB-08-1	1	1/2" Twin Clamp	1460
12	M3-1-4-0015-2	2	Chute Cover	1460
13	M3-1-4-0002	1	Extension Bearing Mount Plate	1460
14	23-0254	1	Conveyor Drive Shaft Weldment	1460
15	M3-1-8-0034	1	Front Conveyor Motor Mount Weldment	1460
16	110-50B16-1.50-1	1	50B16 1-1/2" Bore Sprocket	1460
17	37-0013-1	1	50B16 1" Bore Coupler Sprocket	1460
18	M3-1-8-0006	1	Coupler Cover Plate	1460
19	See Page 100	1	12.25 Cubic Inch 2-Bolt Motor	1460
20	MN3-14-0001-3	2	Chain Cover Plate	1460
21	MN3-14-0001-2	1	Extension Sprocket Cover	1460
22	MN3-14-0003	1	Conveyor Front Panel Weldment	1460
23	MN3-14-0004	2	Conveyor Shield Weldment	1460
24	MN3-14-0004-3	2	Conveyor Panel	1460
25	M3-1-8-0028	2	Front Deflector Mount	1460

FLAT CHAIN CONVEYOR HYDRAULIC SCHEMATIC

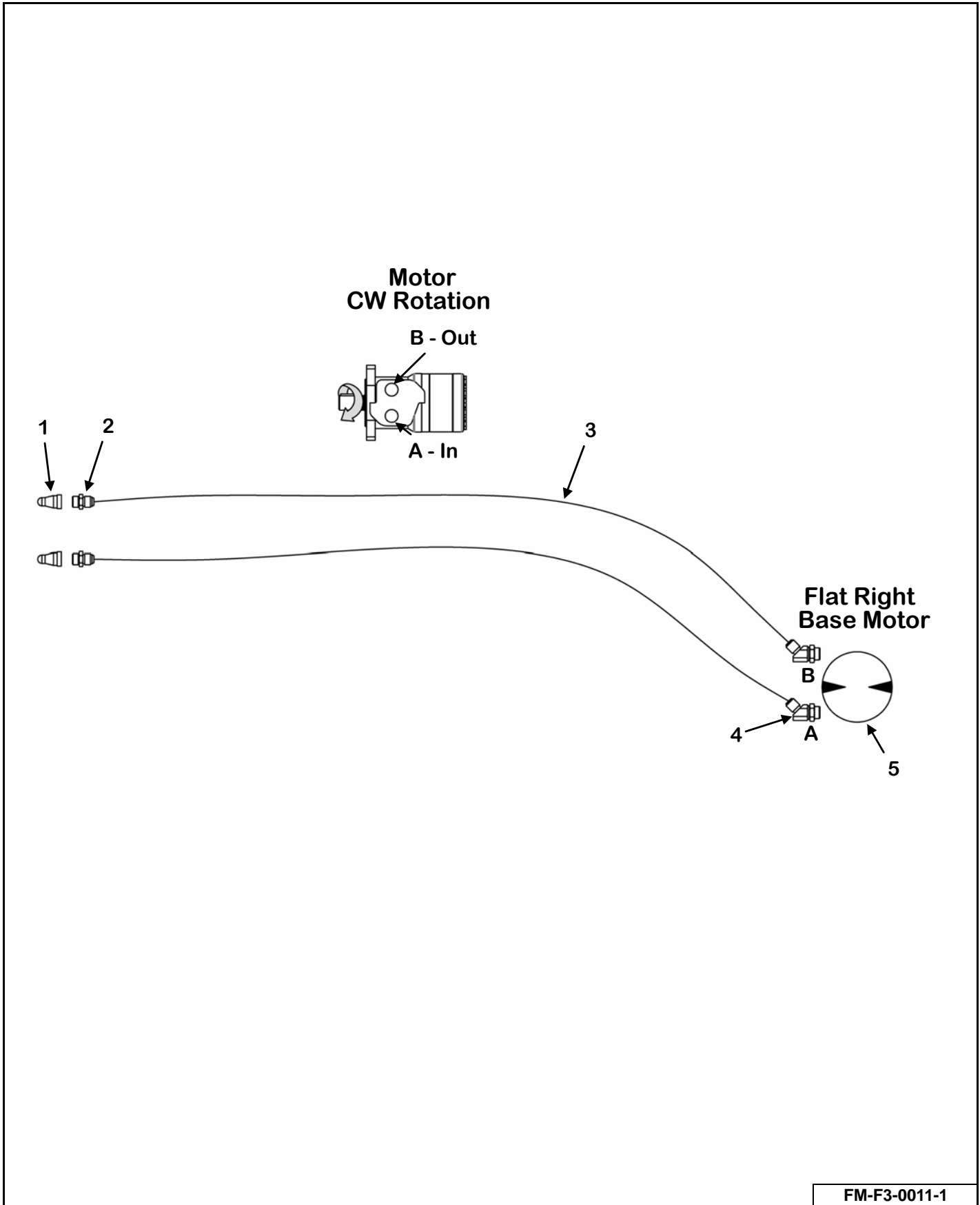

KEY	PART NUMBER	QTY	DESCRIPTION	MIXER MODEL
1	155-8010-15	2	#8 ORB Male Tip 1/2" Body Size	1460
2	155-6400-8-8	2	#8 JIC Male, #8 ORB Male Straight Connector	1460
3	Call 1-800-325-9103	2	____" x ____" Hose Assembly	1460
4	155-6802-8-10	2	#8 JIC Male, #10 ORB Male Adjustable 45°	1460
5	155-BMRSY-12.25-1	1	Hydreco 12.25 Cubic Inch 2-Bolt Motor	1460

DOOR

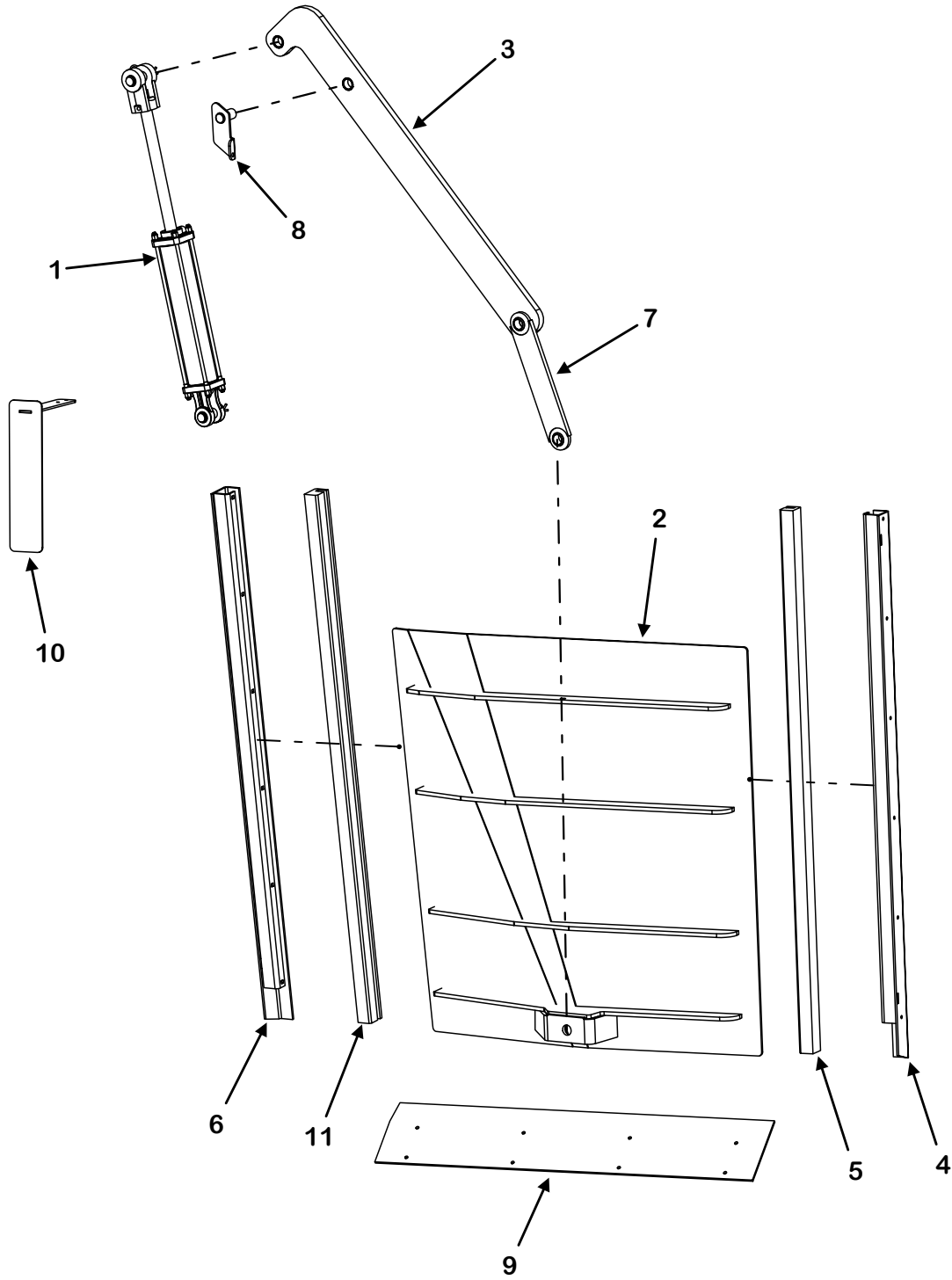

FM-ML-0024-1

KEY	PART NUMBER	QTY	DESCRIPTION	MIXER MODEL
1	155-2.5-12-1.125-1	1	2-1/2" x 12" x 1-1/8" Hydraulic Cylinder	1460
	155-2.5-1.125-1CSK	1	Chief 2-1/2" Bore Seal Kit	1460
	155-2.5-1.125-1DSK	1	Delevan 2-1/2" Bore Seal Kit	1460
	155-2.5-1.125-2MSK	1	Maxim 2-1/2" Bore Seal Kit	1460
2	MN6-14-0001	1	Rear / Front Door Weldment	1460
	MN6-14-0004-S	1	Front Left & Rear Right Side Door Weldment	1460
	MN6-14-0005-S	1	Front Right & Rear Left Side Door Weldment	1460
3	M6-1-8-0006	1	Rear / Front Door Arm	1460
	MN6-14-0006	1	Left / Right Door Arm (Including All Quad Doors)	1460
	M6-1-8-0006-2	2	Spring Bushing 1" ID x 1-1/4" OD x 3/4"	1460
4	M6-1-8-0002	1	Right Door Frame Guide Assembly	1460
5	M6-1-10-0007-R	1	Right Poly Door Slide (Facing Door)	1460
	850-3118-2.5Z	6	Carriage Bolt, 5/16"-18 x 2-1/2"	1460
	814-3118-Z	6	Indented Lock Nut, 5/16"-18	1460
6	M6-1-8-0004	1	Left Door Frame Guide Assembly	1460
7	M6-1-8-0008	1	Door Link Arm Assembly	1460
	851-1008-3Z	2	Machine Bolt, 1"-8 x 3"	1460
	815-1008-Z	2	Lock Nut, 1"-8 Nylon Insert	1460
8	M6-1-8-0009	1	Door Link Pivot Pin Assembly	1460
	851-3816-1.25Z	1	3/8"-16 x 1-1/4" Machine Bolt	1460
	805-0038-Z	2	3/8" Flat Washer	1460
	815-3816-Z	1	3/8"-16 Nylon Insert Lock Nut	1460
9	MN11-1-0016-6	1	Front Left & Rear Right Side Door Magnet Cover Plate	1460
	MN11-1-0017-3	1	Front Right & Rear Left Side Door Magnet Cover Plate	1460
10	46-M-0006	AR	Door Open Indicator Decal	1460
11	M6-1-10-0007-L	1	Left Poly Door Slide (Facing Door)	1460
	850-3118-2.5Z	6	Carriage Bolt, 5/16"-18 x 2-1/2"	1460
	814-3118-Z	6	Indented Lock Nut, 5/16"-18	1460

FRONT & REAR DOOR HYDRAULIC SCHEMATIC

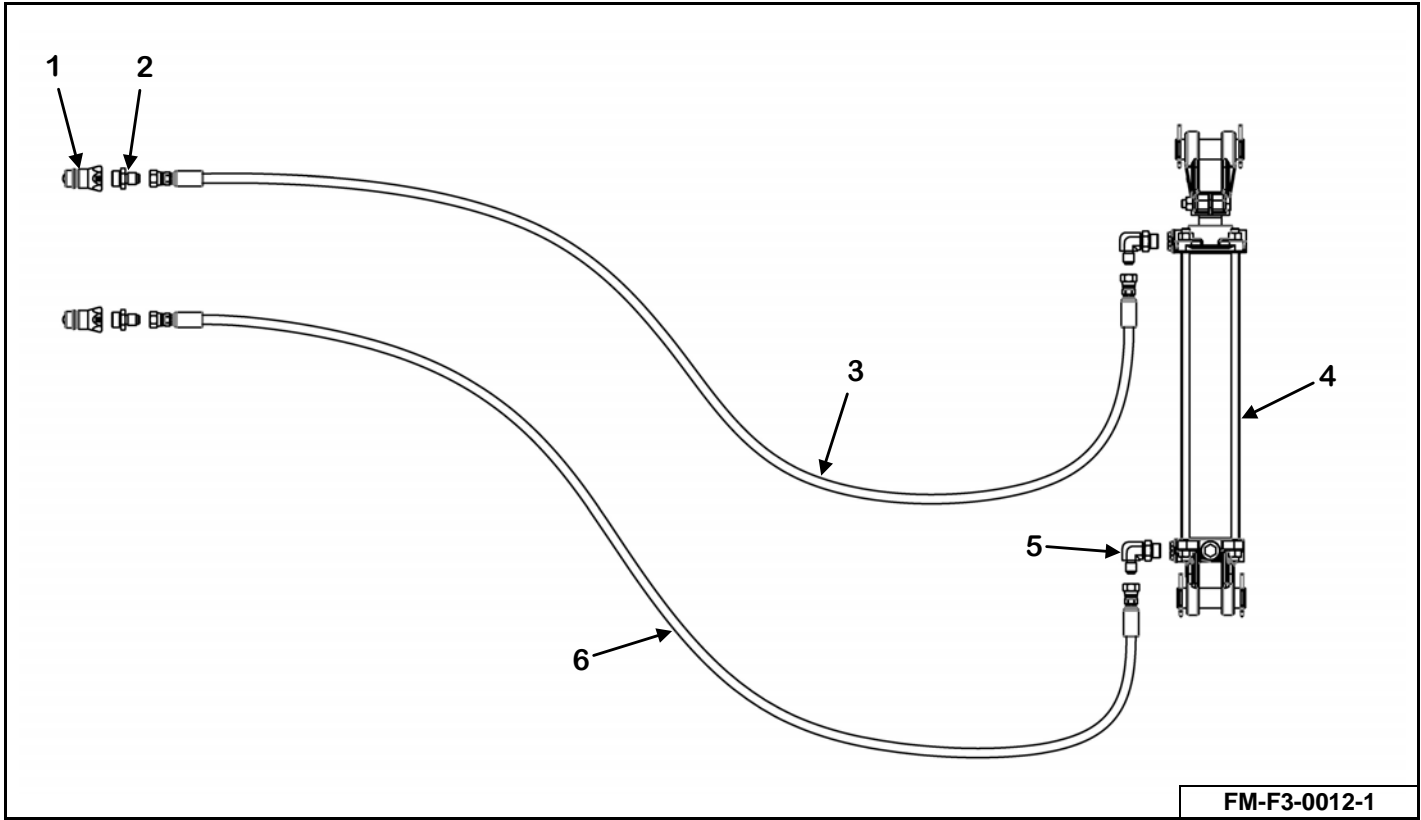

KEY	PART NUMBER	QTY	DESCRIPTION	MIXER MODEL
1	155-8010-15	2	#8 ORB Male Tip 1/2" Body Size	1460
2	155-6400-6-8	2	#6 JIC Male, #8 ORB Male Straight Connector	1460
3	155-04R17-242-1	1	1/4" x 242" Hose Assembly (Front Door)	1460
	155-04R17-481-1	1	1/4" x 481" Hose Assembly (Front Discharge Rear Door)	1460
	155-04R17-459-1	1	1/4" x 459" Hose Assembly (Side/Quad Discharge Rear Door)	1460
4	See Page 106	1	2-1/2" x 12" x 1-1/8" Hydraulic Cylinder	1460
5	155-6801-6-8	2	#6 JIC Male, #8 ORB Male Adjustable 90°	1460
6	155-04R17-227-1	1	1/4" x 227" Hose Assembly (Front Door)	1460
	155-04R17-466-1	1	1/4" x 466" Hose Assembly (Front Discharge Rear Door)	1460
	155-04R17-444-1	1	1/4" x 444" Hose Assembly (Side/Quad Discharge Rear Door)	1460

QUAD DOOR HYDRAULIC SCHEMATIC

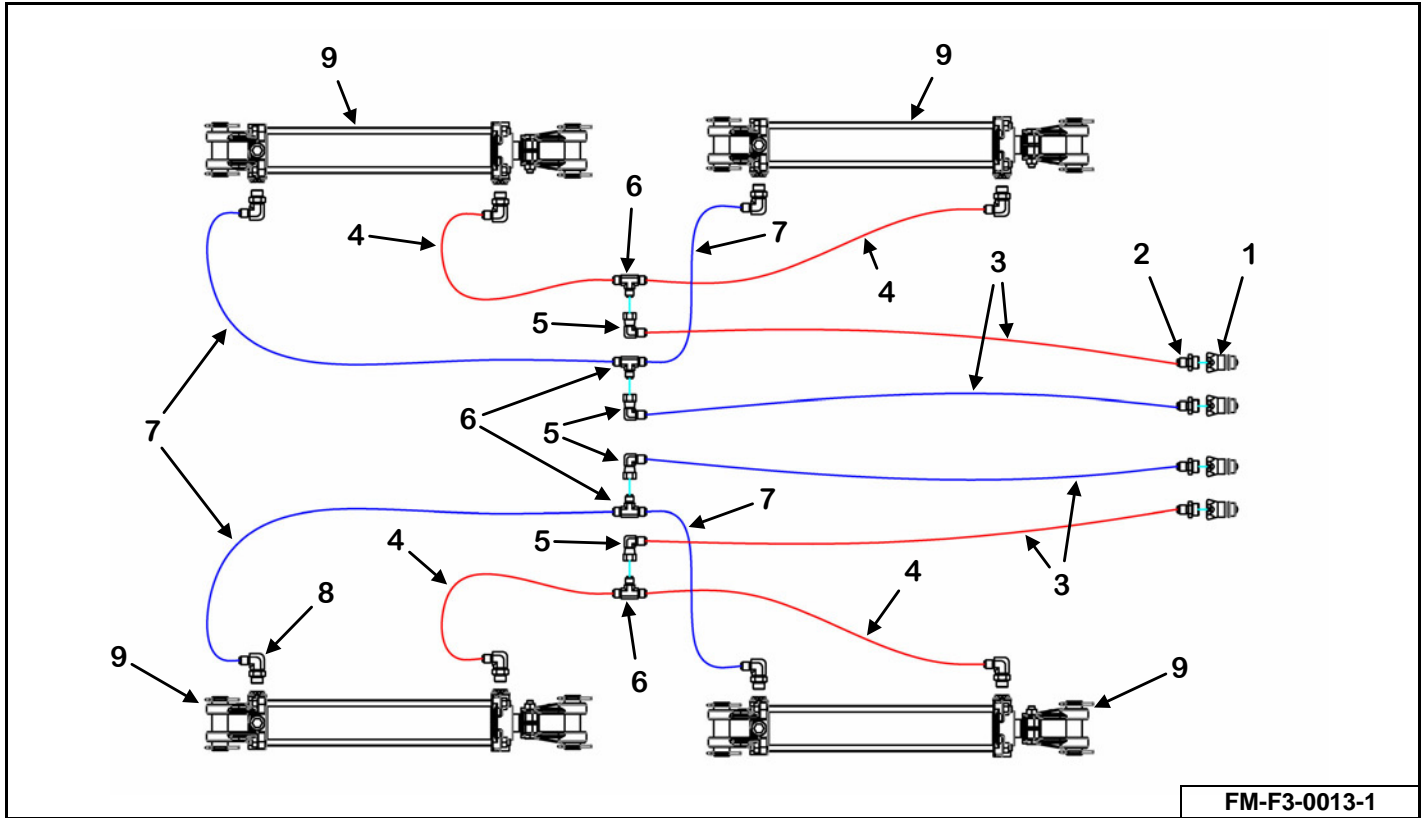

KEY	PART NUMBER	QTY	DESCRIPTION	MIXER MODEL
1	155-8010-15	4	#8 ORB Male Tip 1/2" Body Size	1460
2	155-6400-6-8	4	#6 JIC Male, #8 ORB Male Straight Connector	1460
3	155-04R17-314-1	4	1/4" x 314" Hose Assembly (SN 22VM1460202 Only)	1460
	155-04R17-278-1	4	1/4" x 278" Hose Assembly	1460
4	155-04R17-167-1	4	1/4" x 167" Hose Assembly	1460
5	155-6500-06-06	4	90° Fitting	1460
6	155-2603-06-06-06	4	Tee	1460
7	155-04R17-152-1	4	1/4" x 152" Hose Assembly	1460
8	155-6801-6-8	8	#6 JIC Male, #8 ORB Male Adjustable 90°	1460
9	See Page 106	1	2-1/2" x 12" x 1-1/8" Hydraulic Cylinder	1460

VIEWING PLATFORM

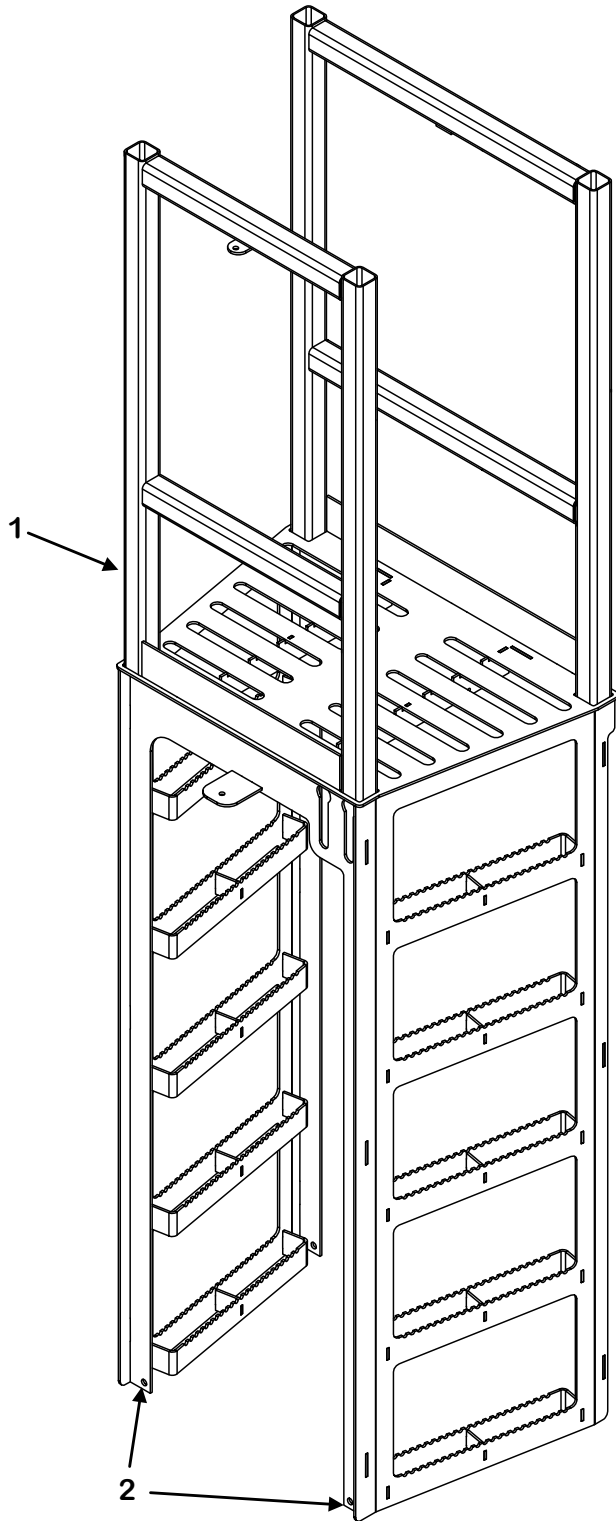

FM-F3-0015-1

KEY	PART NUMBER	QTY	DESCRIPTION	MIXER MODEL
1	M310-1-18-0001	1	Viewing Platform Weldment, Front Discharge	1460
	MN10-1-14-0001	1	Viewing Platform Weldment, Side/Quad Discharge	1460
2	810-5013-Z	4	1/2" Spin Lock Nut	1460
	851-5013-1.25Z	4	1/2"-13 x 1-1/4" Machine Bolt	1460

AUGER

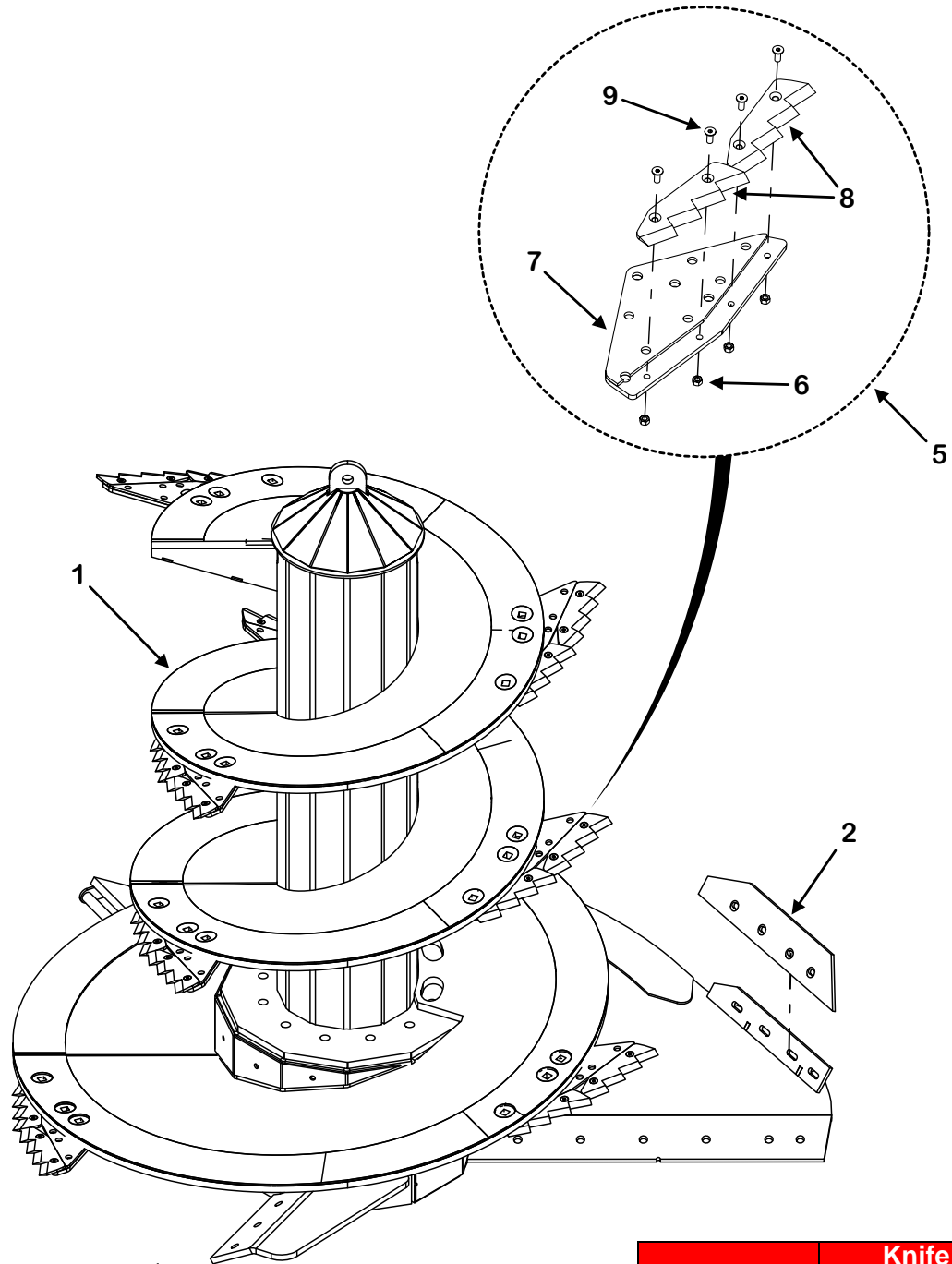

Mixer Model	Knife Assembly Per Auger
1460	7 to 10

FM-F3-0014-1

KEY	PART NUMBER	QTY	DESCRIPTION	MIXER MODEL
0	MN5-14-0017	3	Auger Assembly, Complete With Knives, Backer & Hardware	1460
1	MN5-14-0015-1	3	Auger Weldment	1460
2	MN5-14-0001-1	3	Auger Scraper	1460
3	MN5-14-0008-1	6	Kicker Weldment	1460
	MN5-14-0008	6	Kicker Weldment With Magnet Kit	1460
	851-7510-2.5Z	18	3/4"-10 x 2-1/2" Bolt	1460
	815-7510-Z	18	3/4"-10 Nylon Insert Lock Nut	1460
4	M3-1-8-0020-4	AR	Kicker Magnet	1460
	851-2520-.75Z	2 per	1/4"-20 x 3/4" Hex Cap Screw	1460
	822-0025-Z	2 per	1/4" Split Lock Washer	1460
5	M11-1-0059-K	AR	Mixer Knife Assembly (Includes Knives, Backer & Hardware)	1460
6	814-3816-Z	4 Per	3/8"-16 Hex Center Lock Nut	1460
7	M11-1-0040	AR	Knife Backer Weldment	1460
	880-6311-2Z	2 Per	5/8"-11 x 2" Carriage Bolt	1460
	886-6311-Z	2 Per	5/8"-11 Center Lock Nut	1460
8	M11-1-0050-K	2 Per	Wide Knife Kit (Includes 1 Knife With Hardware)	1460
9	803-3816-1Z	4 Per	3/8"-16 x 1" Flat Socket Head Cap Screw	1460

POWER SHIFT DRIVELINE

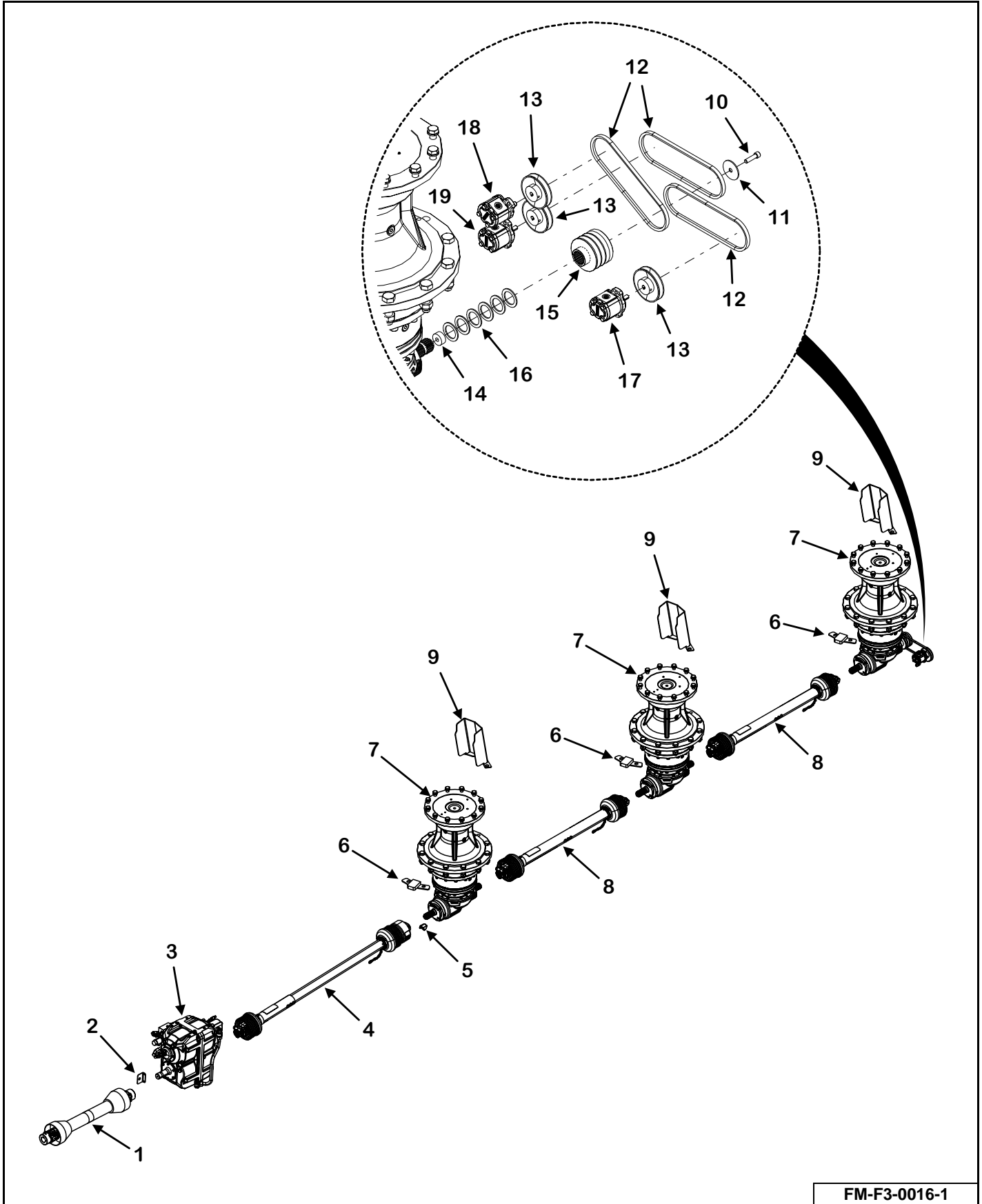

FM-F3-0016-1

KEY	PART NUMBER	QTY	DESCRIPTION	MIXER MODEL
1	See Page 128	1	Primary PTO Drive Shaft	1460
2	MN11-1-0002-2	1	Speed Switch Mount Plate	1460
3	See Pages 116 & 118	1	Zuidberg 2-Speed Automatic Transmission	1460
4	See Page 130	1	Front Discharge Secondary PTO Drive Shaft	1460
	See Page 134	1	Side/Quad Discharge Secondary PTO Drive Shaft	1460
5	M9-1-8-0011	1	Rotation Counter Bracket	1460
6	MN11-1-0001	3	Floor Cover Weldment	1460
7	See Page 120	3	3003 Series Planetary Gearbox	1460
8	See Page 136	2	Intermediate PTO Drive Shaft	1460
9	MN2-14-0008	3	Gearbox Breather Guard Weldment	1460
10	831-M12-1.75-45	1	M12-1.75 x 45mm Allen Head Cap Screw (Optional)	1460
11	601-0001-65	1	Drive Shaft Cap Washer (Optional)	1460
12	49-0533	3	V-Belt (Optional)	1460
13	12-0069	3	1/2" Bore Single Sheave Pulley (Optional)	1460
14	MN11-1-0005-3	1	Bushing (Optional)	1460
15	MN11-1-0005	1	Pulley Weldment (Optional)	1460
16	808-1.75-2.5-10	6	Machine Bushing (Optional)	1460
17	See Page 156	1	Rear Planetary Oil Cooling System (Optional)	1460
18	See Page 152	1	Front Planetary Oil Cooling System (Optional)	1460
19	See Page 154	1	Middle Planetary Oil Cooling System (Optional)	1460

POWER SHIFT TRANSMISSION (EXTERNALS)

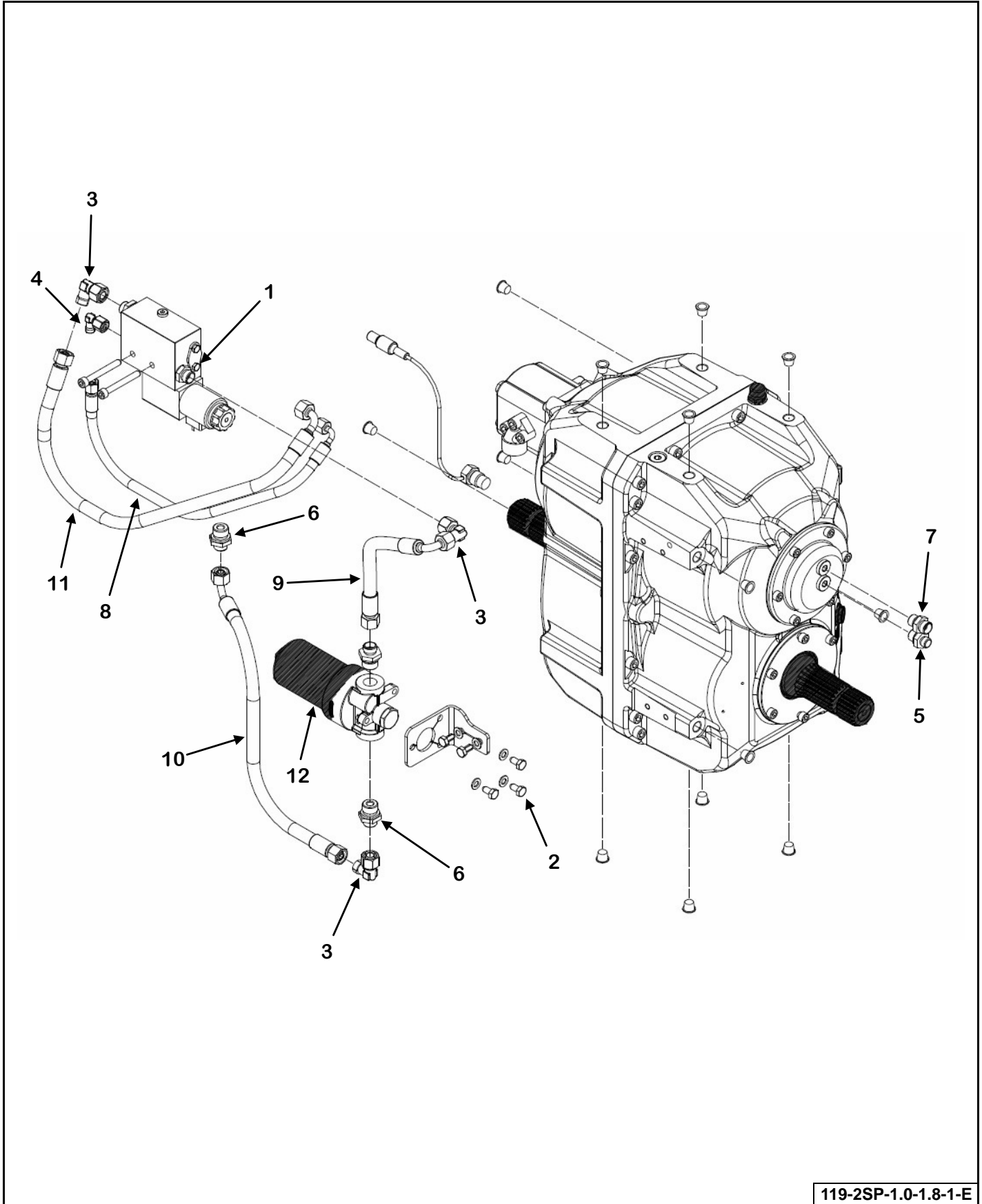

119-2SP-1.0-1.8-1-E

KEY	PART NUMBER	QTY	DESCRIPTION
0	119-2SP-1.0-1.8-1	1	Zuidberg 2-Speed Automatic Transmission
	119-Z-14	1	Clutch Service Kit (Includes Steels, Frictions, Seals, Springs, & Pins)
1	119-Z-04	1	Hydraulic Valve Block
2	851-M8-1.25-16-Z	5	M8-1.25 x 16mm Hex Cap Screw
3	119-Z-05	3	90° Elbow
4	119-Z-06	1	90° Elbow
5	119-Z-07	1	Straight Adapter
6	119-Z-08	1	Straight Adapter
7	119-Z-09	1	Straight Adapter
8	119-Z-10	1	Hose
9	119-Z-11	1	Hose
10	119-Z-12	1	Hose
11	119-Z-13	1	Hose
12	119-Z-01	1	Filter Housing With Filter Element
	119-Z-01-1	1	Filter Element Only

POWER SHIFT TRANSMISSION (INTERNALS)

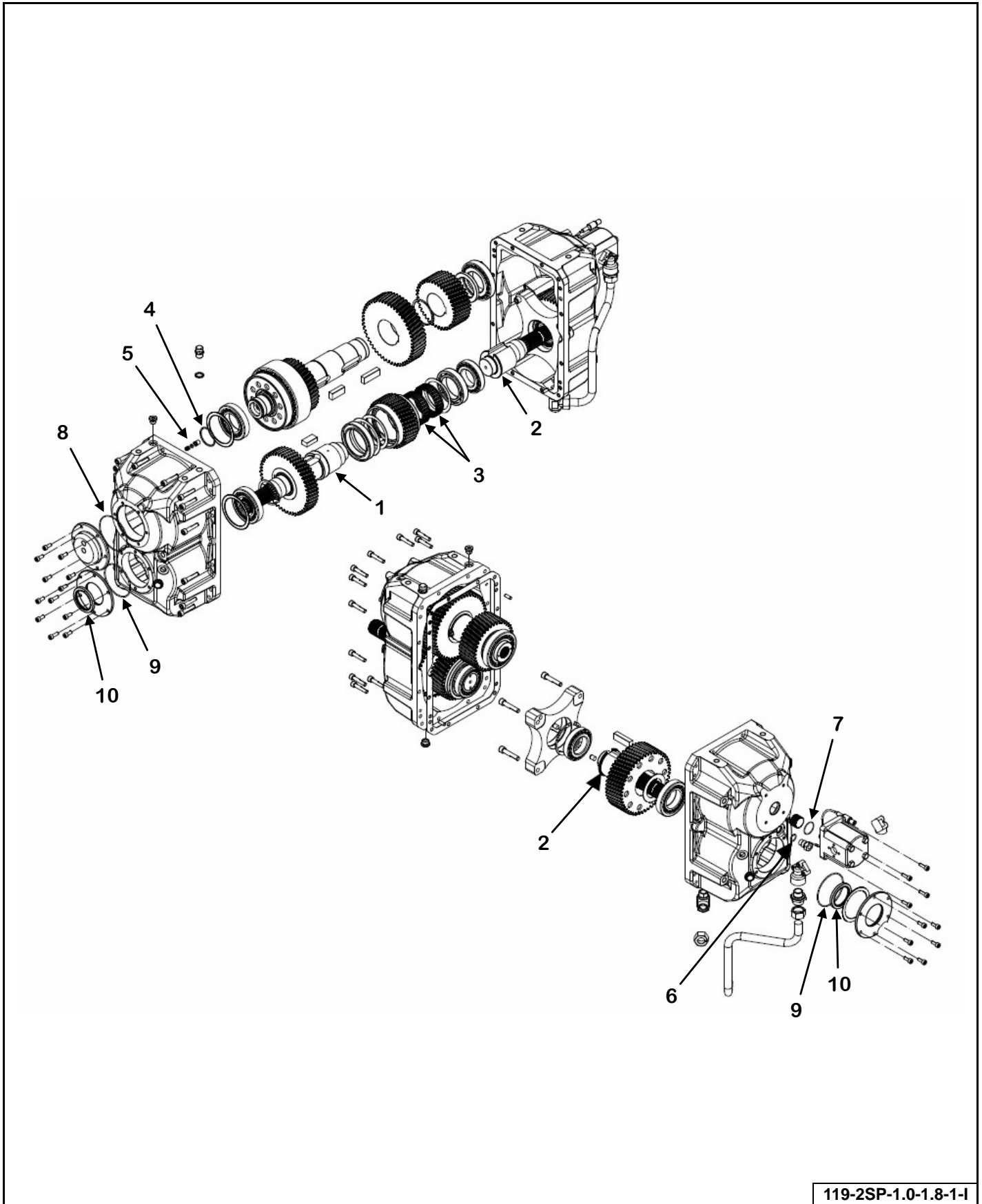

119-2SP-1.0-1.8-1-I

KEY	PART NUMBER	QTY	DESCRIPTION
1	119-Z-15	1	Shaft
2	119-Z-16	1	Shaft
3	119-Z-17	2	Ratchet Overrun Bearing
4	119-Z-18	1	Piston Ring
5	119-Z-19	1	O-Ring
6	119-Z-20	1	O-Ring
7	119-Z-21	1	O-Ring
8	119-Z-22	1	O-Ring
9	119-Z-23	2	O-Ring
10	119-Z-24	2	Oil Seal

POWER SHIFT TRANSMISSION OIL COOLING SYSTEM

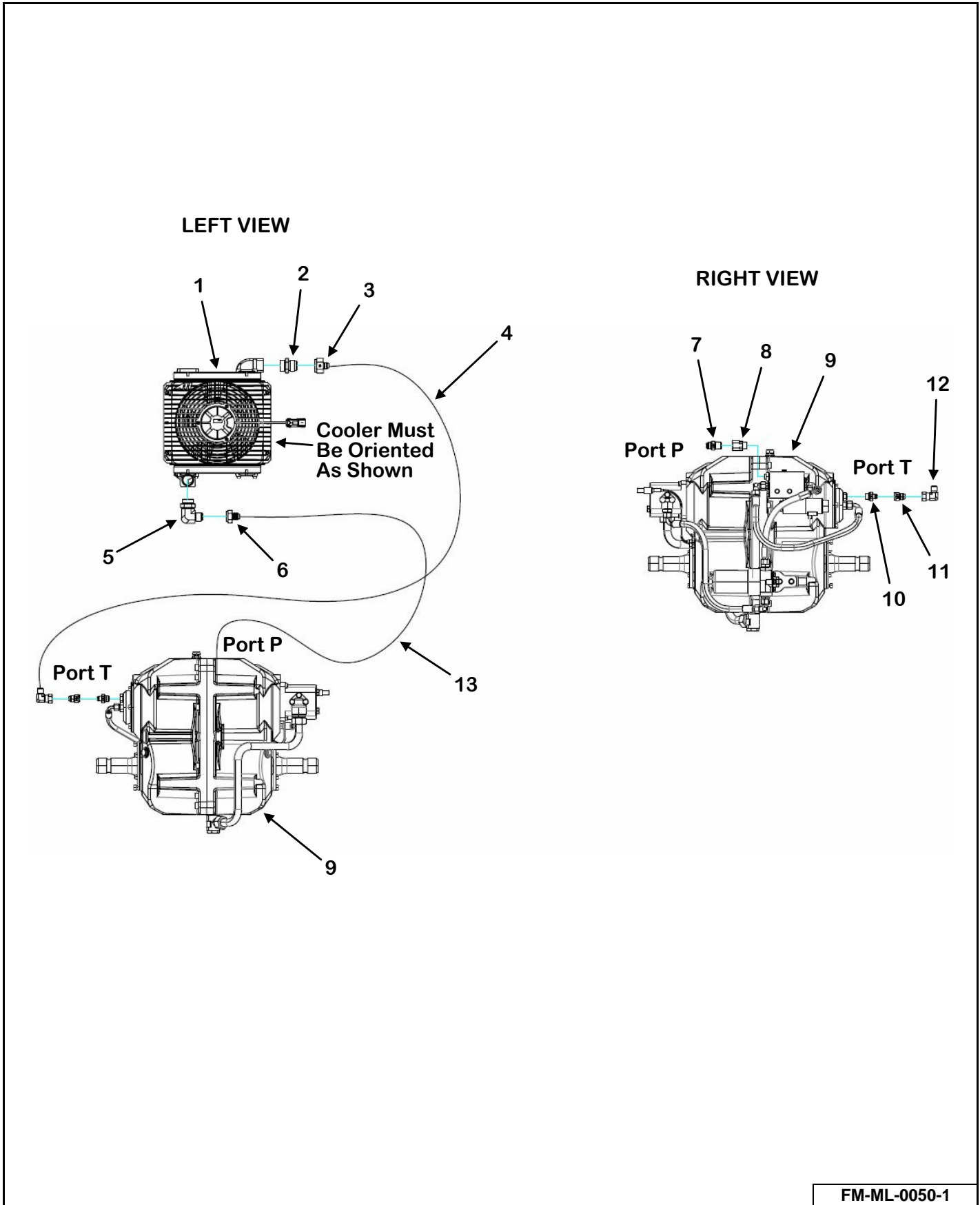

FM-ML-0050-1

KEY	PART NUMBER	QTY	DESCRIPTION	MIXER MODEL
1	155-OC-TT07-1	1	12V Hydraulic Cooler	1460
2	155-6400-16-16	1	Straight Adapter	1460
3	155-2406-16-8	1	Straight Adapter	1460
4	155-08R17-69-1	1	1/2" x 69" Hose	1460
5	155-6801-12-16	1	90° Adapter	1460
6	155-2406-12-08	1	Straight Adapter	1460
7	155-2404-08-08	1	Straight Adapter	1460
8	155-P08-08	1	Straight Adapter	1460
9	See Pages 116 & 118	1	Zuidberg 2-Speed Automatic Transmission	1460
10	155-7005-06-16	1	Straight Adapter	1460
11	155-2406-06-08	1	Straight Adapter	1460
12	155-6500-08-08	1	90° Adapter	1460
13	155-08R17-52-1	1	1/2" x 52" Hose	1460

3003 SERIES PLANETARY

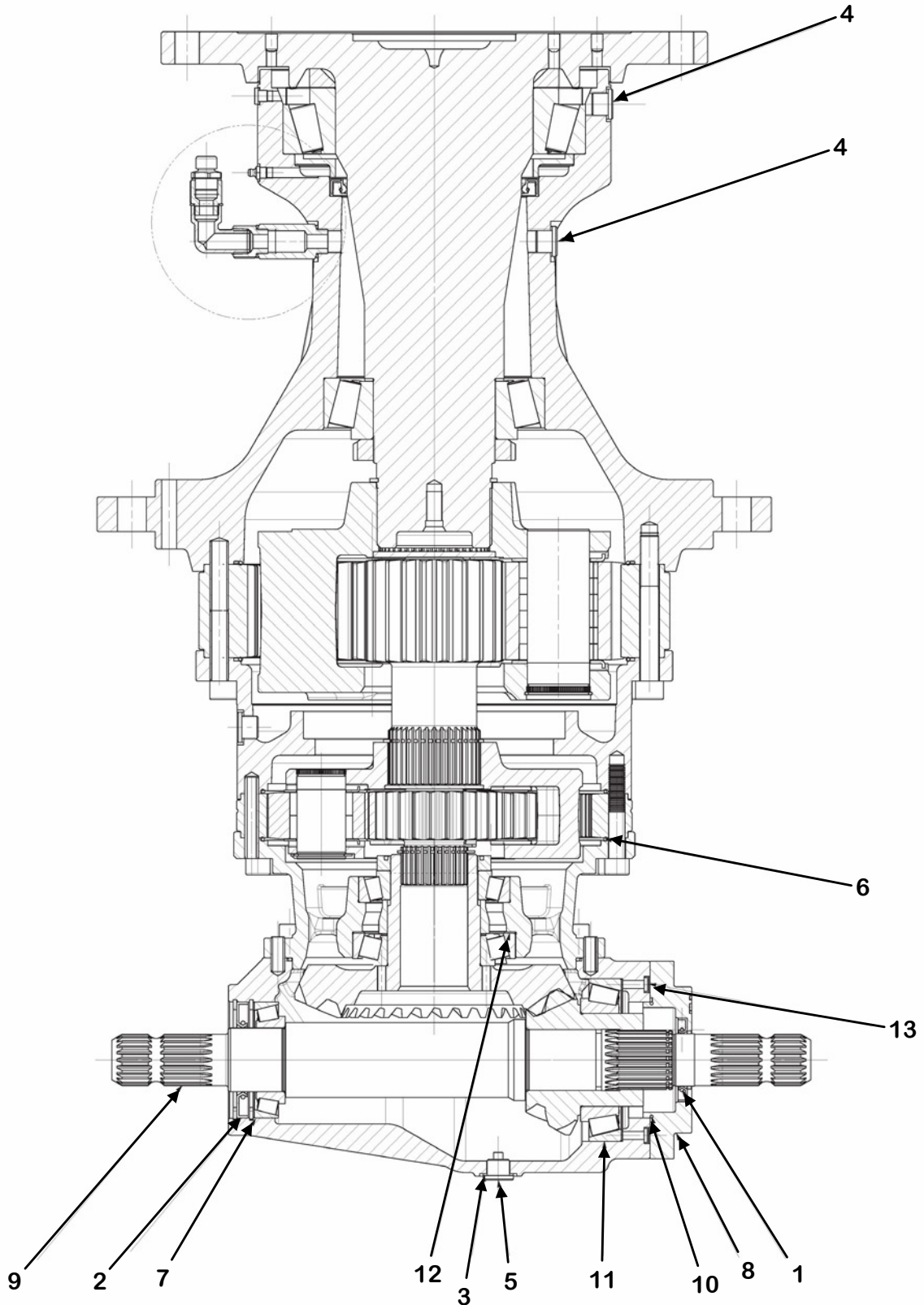

119-30-24.3-2

KEY	PART NUMBER	QTY	DESCRIPTION
0	119-30-24.3-2	3	3003 Series Planetary Gearbox
1	119-P-CI-4	1 Per	Oil Seal
2	119-P-CI-5	1 Per	Oil Seal
3	119-P-CI-6	1 Per	Washer
4	119-P-CI-7	4 Per	1/2" Plug
5	119-P-CI-8	1 Per	1/2" Magnetic Plug
6	119-P-CI-10	1 Per	O-Ring
7	119-P-CI-21	1 Per	Shim Kit
8	119-P-CI-25	1 Per	Cover
9	119-P-CI-26	1 Per	1-3/4" Shaft
10	119-P-CI-29	1 Per	O-Ring
11	119-P-CI-30	1 Per	Bearing
12	119-P-CI-32	2 Per	Shim Kit
13	119-P-CI-33	2 Per	Plug

PLANETARY GEARBOX OIL SYSTEM

Front

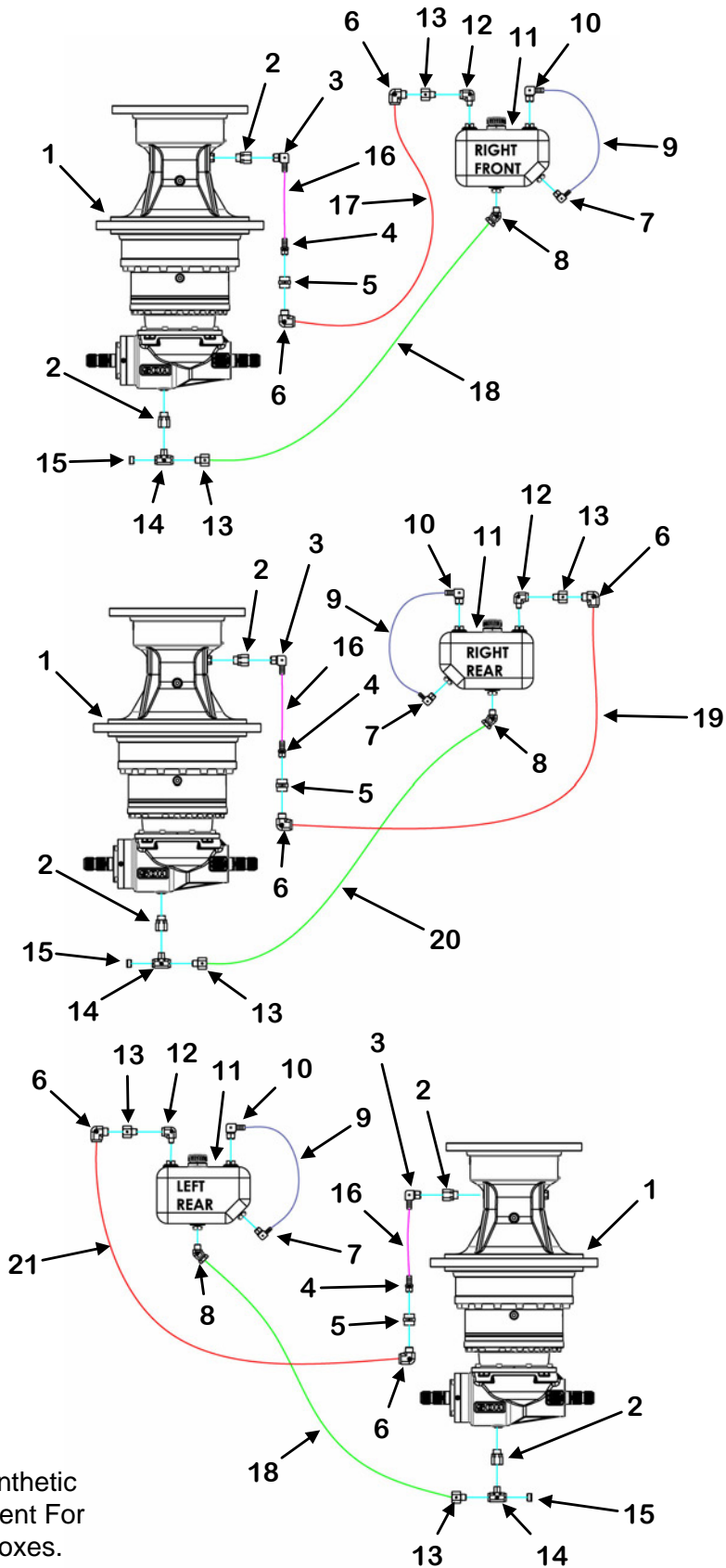

Use #48-0081 Synthetic ISO220 or Equivalent For Planetary Gearboxes.

Rear

FM-F3-0017-1

KEY	PART NUMBER	QTY	DESCRIPTION	MIXER MODEL
1	See Page 122	3	3003 Series Planetary Gearbox	1460
2	155-PB08-08	6	Straight Adapter	1460
3	55-0406	3	90° 1/2" Hose Barb	1460
4	55-0410	3	Straight 1/2" Hose Barb	1460
5	55-0039	3	Straight Adapter	1460
6	55-0082	6	90° Fitting	1460
7	55-0419	3	90° 3/8" Hose Barb	1460
8	155-1503-08-12	3	45° Adapter	1460
9	155-06-7-15	3	3/8" x 15" Clear PVC Hose	1460
10	55-0401	3	90° 3/8" Hose Barb	1460
11	952-0005	3	2-1/2 Gallon Plastic Tank With Vented Cap	1460
12	155-5502-06-08	3	90° Adapter	1460
13	155-5405-08-12	6	Straight Adapter	1460
14	155-5604-08-08-08	3	Tee	1460
15	155-5406-HP-08	3	Hex Plug	1460
16	155-08-6-13	3	1/2" x 13" Hose	1460
17	155-12-82-1	1	3/4" x 82" Hose Assembly	1460
18	155-12-93-1	2	3/4" x 93" Hose Assembly	1460
19	155-12-110-1	1	3/4" x 110" Hose Assembly	1460
20	155-12-105-1	1	3/4" x 105" Hose Assembly	1460
21	155-12-106-1	1	3/4" x 106" Hose Assembly	1460

PLANETARY GREASE COMPONENTS

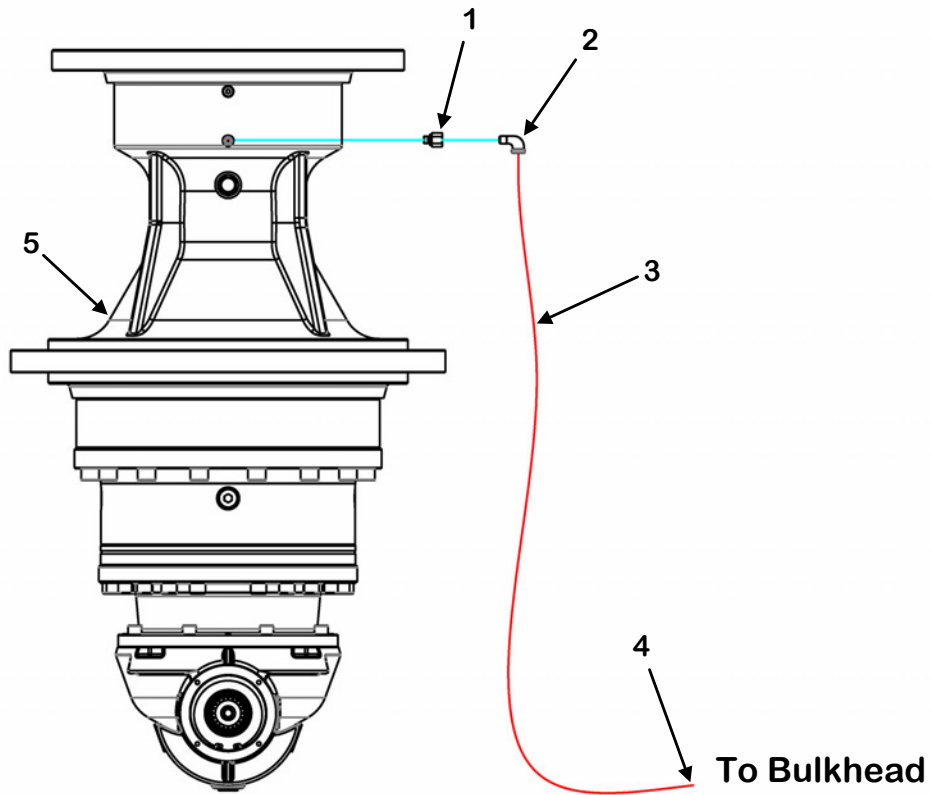

FM-F3-0018-1

KEY	PART NUMBER	QTY	DESCRIPTION	MIXER MODEL
1	155-PB2-2	3	Straight Fitting	1460
2	30-0020	3	1/8" NPT 90° Elbow	1460
3	155-02R7-88-1-1	1	Front Planetary 1/8" x 88" Hose	1460
	155-02R7-111-1-1	1	Middle Planetary 1/8" x 111" Hose	1460
	155-02R7-111-1-1	1	Rear Planetary 1/8" x 111" Hose	1460
4	30-0001	3	1/4"-28 Straight Grease Fitting	1460
	155-2GK-NUT	3	Bulkhead Adapter Nut	1460
5	See Page 122	3	3003 Series Planetary Gearbox	1460

PRIMARY PTO DRIVE SHAFT

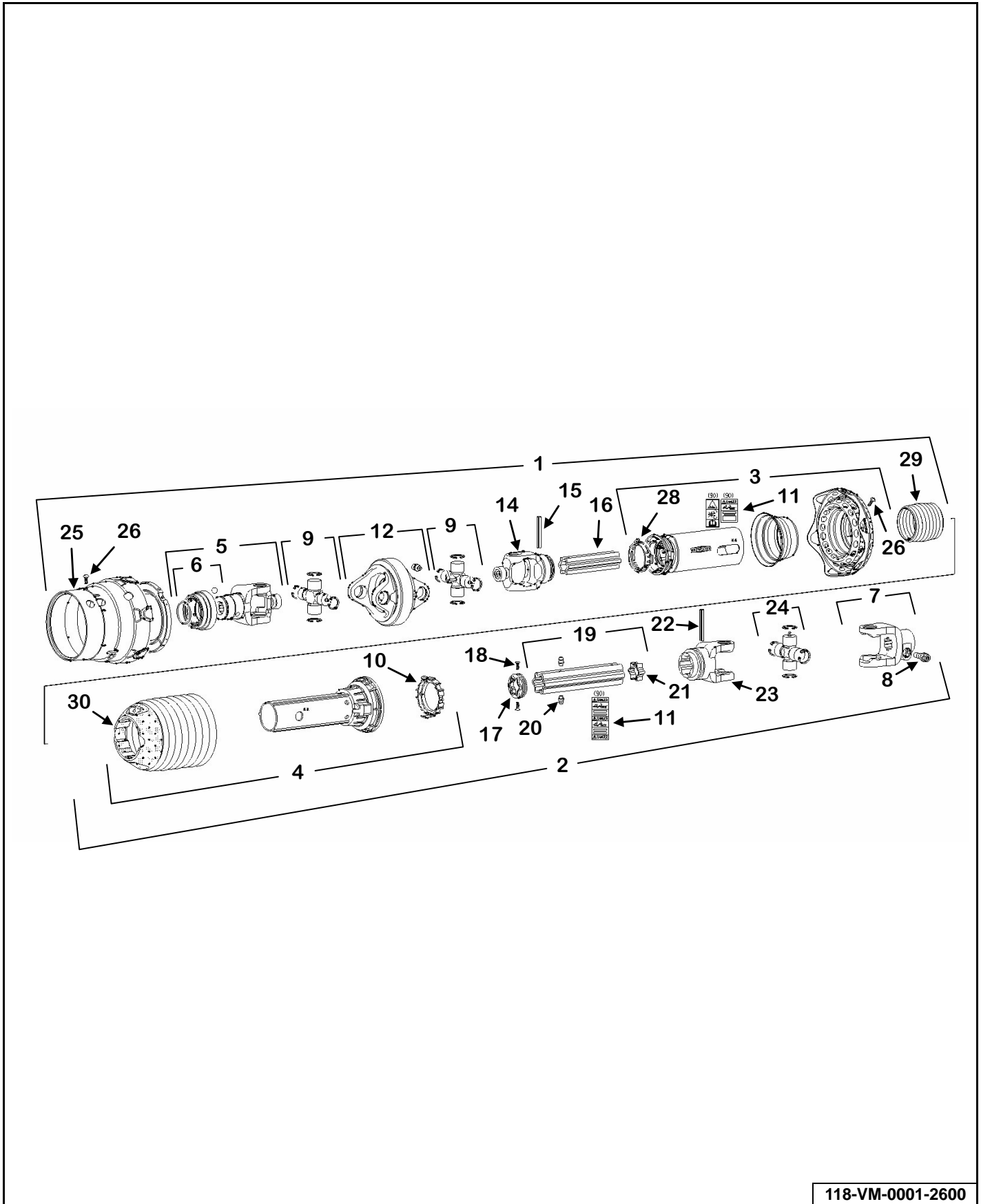

118-VM-0001-2600

KEY	PART NUMBER	QTY	DESCRIPTION
0	118-VM-0001-2600	1	1-3/4"-20 Spline PTO Complete
1	118-VM-0001-2600-1	1	Tractor PTO Half
2	118-VM-0001-2600-2	1	Implement PTO Half
3	118-2600-1	1	Outer Guard Half
4	118-2600-2	1	Inner Guard Half
5	118-2600-3	1	Yoke
6	118-2600-4	1	Lock
7	118-2600-5	1	Yoke With Lock
8	918-0410-2-1-1	1	Clamping Cone
9	118-2600-6	2	Cross & Bearing Kit Complete
	118-2600-7	2	Zerk
	118-2600-8	2	Hose
10	118-2600-23	1	Bearing Ring
11	118-2600-24	1	Instruction Manual With Set Of Decals
12	118-2600-9	1	Double Yoke
13	918-0208-1-2	1	Zerk
14	118-2600-10	1	Inboard Yoke
15	918-0208-1-6	1	Spring Type Straight Pin
16	118-2600-11	1	Hardened Tube Profile
17	118-2600-12	1	Seal Ring For Outer Profile
18	118-2600-13	2	Screw
19	118-2600-14	1	Profile Tube With Zerk
20	918-0208-1-12	2	Zerk
21	118-2600-15	1	Plug
22	118-2600-16	1	Spring Type Straight Pin
23	118-2600-17	1	Inboard Yoke
24	118-2600-18	1	Cross & Bearing Kit Complete
	118-2600-7	1	Zerk
25	118-2600-19	1	Guard Cone
26	918-0208-2-9	9	Screw
27	118-2600-20	1	Bearing Ring
28	918-0208-2-4	1	Bearing Ring
29	118-2600-21	1	Cover
30	118-2600-22	1	Guard Cone

PRIMARY PTO DRIVE SHAFT (OPTIONAL)

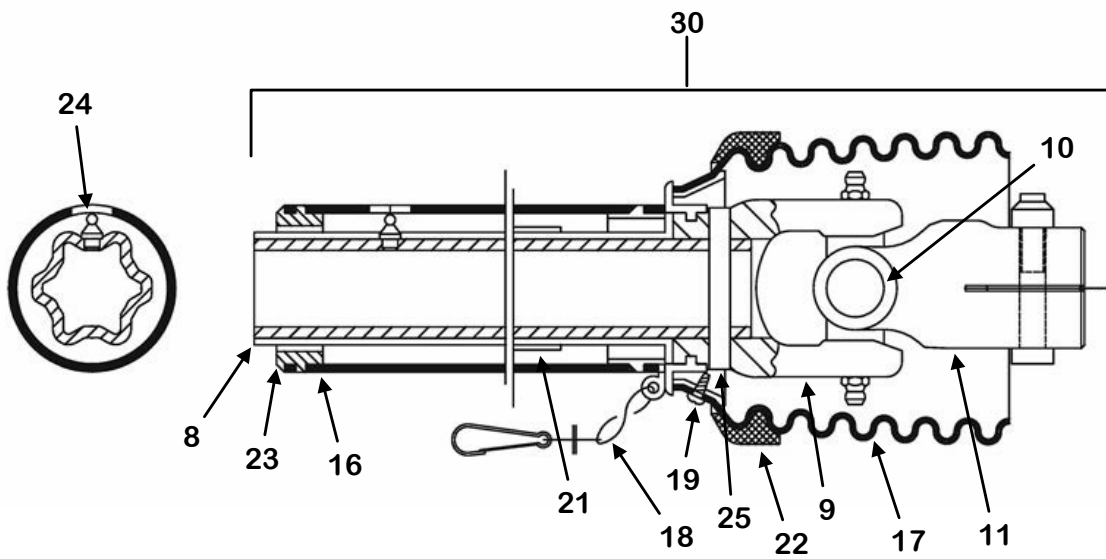
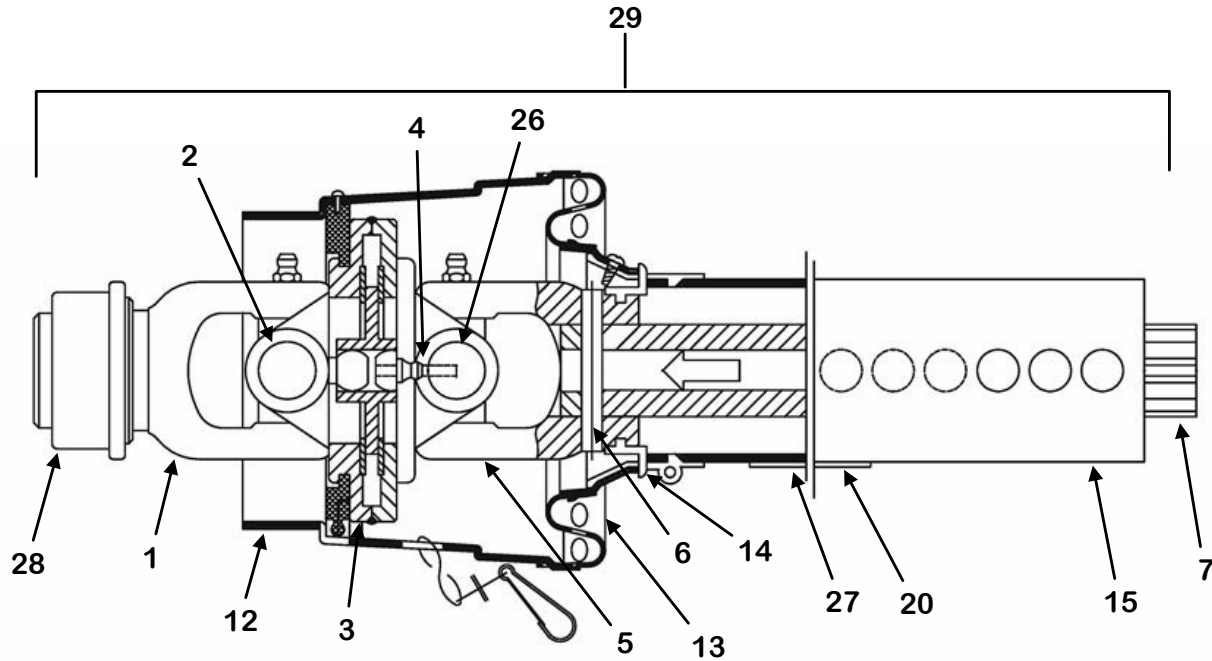

118-VM-0024-55

KEY	PART NUMBER	QTY	DESCRIPTION
0	No Longer Used	1	See Page 128 For PTO Complete Replacement
1	918-0512-1-1	1	Yoke ASG (Includes Item 28)
2	918-0511-1-2	1	Cross & Bearing Kit
3	918-0511-1-3	1	Double Yoke (Includes Item 4)
4	918-0208-1-2	1	Zerk
5	918-0511-1-5	1	Inboard Yoke
6	918-0308-1-5	1	Spring Pin, 10 x 75
7	118-VM-0024-55-3	1	Inner Profile
8	118-VM-0024-55-4	1	Outer Profile (Includes Items 21 & 24)
9	618-0201-2-2	1	Inboard Yoke
10	118-VM-0010-25-2	1	Cross & Bearing Kit
11	118-VM-0010-25-1	1	Yoke 1-3/4"-20 SPL
12	618-0202-1-11	1	CV Guard & Bearing Assembly (Includes Item 19)
13	918-0212-1-5	1	Flex Net & Guard Assembly (Includes Item 19)
14	918-0208-2-4	2	Bearing Ring SC25
15	118-VM-0024-55-5	1	Guard Tube Outer (Includes Item 20)
16	118-VM-0024-55-6	1	Guard Tube Inner
17	118-VM-0024-55-7	1	Guard Cone, 7 Rib (Includes Item 19)
18	918-0208-2-7	2	Restraint Chain
19	918-0208-2-9	10	Screw
20	918-0208-2-8	1	Decal Outer
21	918-0208-1-10	1	Decal Inner
22	618-0202-2-8	1	Reinforcing Collar
23	618-0202-1-10	1	Support Bearing
24	618-0208-1-12	1	Zerk
25	618-0202-2-5	1	Spring Pin, 10 x 90
26	918-0511-1-4	1	Cross & Bearing Kit
27	918-0308-2-6	1	Decal, Lubrication
28	918-0210-1-1-1	1	ASG Collar Kit
29	118-VM-0024-55-1	1	Tractor Half Shaft
30	118-VM-0024-55-2	1	Implement Half Shaft

FRONT DISCHARGE SECONDARY PTO DRIVE SHAFT

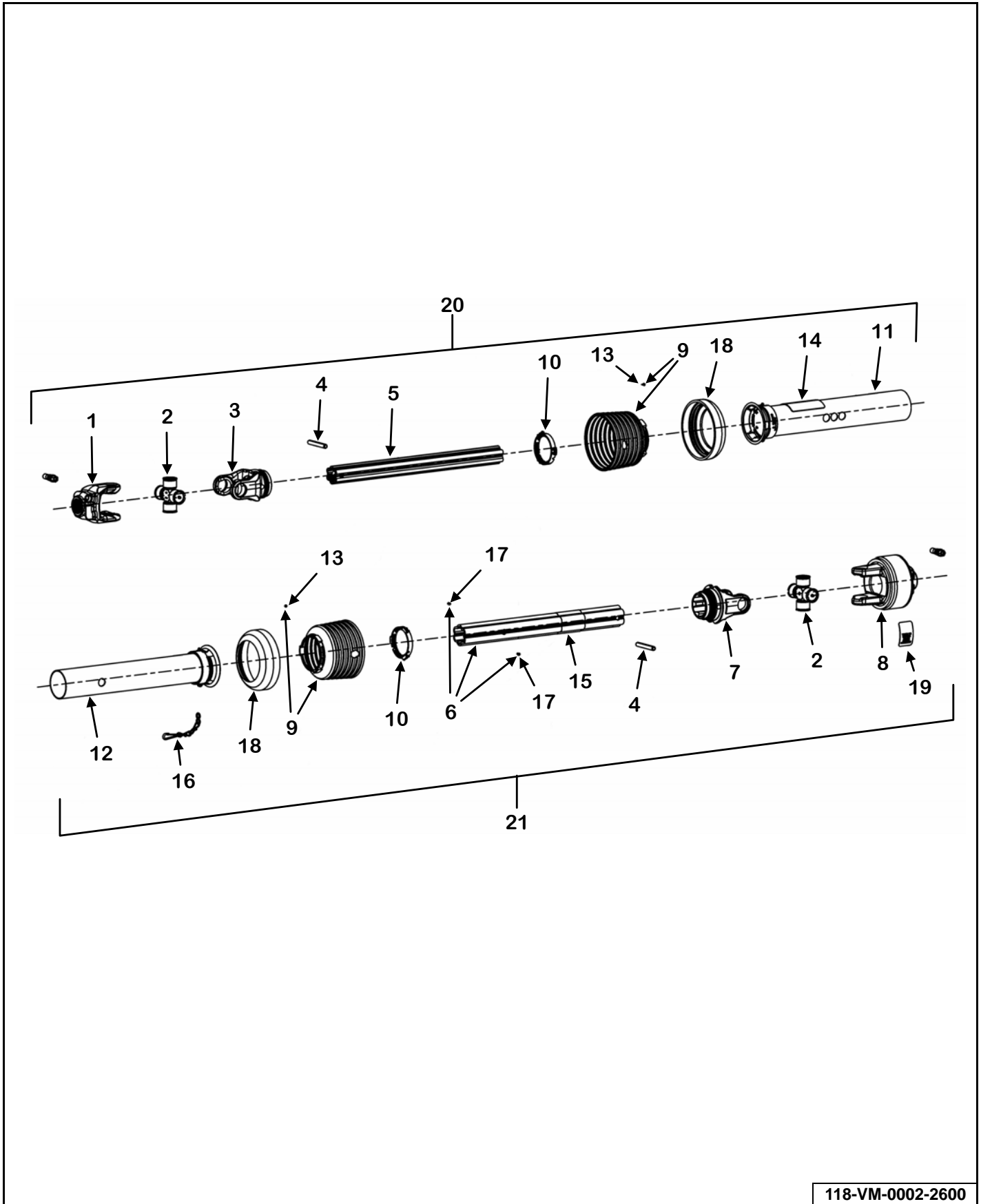

118-VM-0002-2600

KEY	PART NUMBER	QTY	DESCRIPTION
0	118-VM-0002-2600	1	1-3/4"-20 Spline PTO Complete
1	118-2600-5	1	Yoke
2	118-2600-26	2	Cross & Bearing Kit
3	118-2600-27	1	Inboard Yoke
4	118-2600-16	2	Spring Pin
5	118-2600-37	1	Inner Profile
6	118-2600-38	1	Outer Profile
7	118-2600-30	1	Inboard Yoke
8	See Page 138	1	Cutout Clutch
9	118-2600-32	2	Guard Cone
10	118-2600-33	2	Bearing Ring
11	118-2600-40	1	Guard Tube Outer
12	118-2600-41	1	Guard Tube Inner
13	918-0208-2-9	2	Screw
14	918-0208-2-8	1	Decal Outer
15	918-0208-1-10	1	Decal Inner
16	918-0208-2-7	1	Restraint Chain
17	918-0208-1-12	2	Zerk
18	118-2600-36	2	Reinforcing Collar
19	918-0208-2-10	1	Decal
20	118-VM-0002-2600-1	1	Power Shift Transmission Half
21	118-VM-0002-2600-2	1	Planetary Half

SIDE/QUAD DISCHARGE SECONDARY PTO DRIVE SHAFT

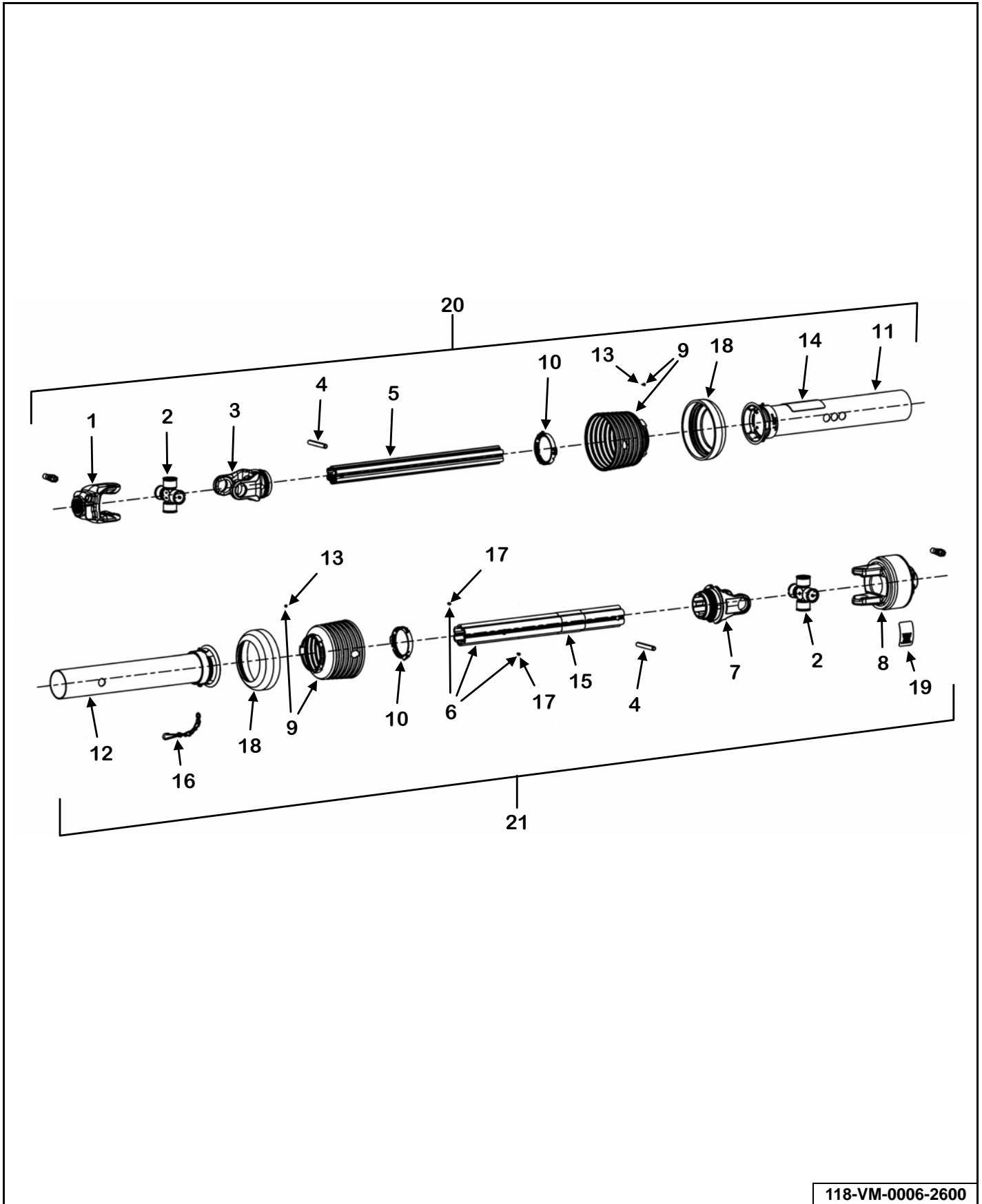

118-VM-0006-2600

KEY	PART NUMBER	QTY	DESCRIPTION
0	118-VM-0006-2600	1	1-3/4"-20 Spline PTO Complete
1	118-2600-5	1	Yoke
2	118-2600-18	2	Cross & Bearing Kit
3	118-2600-27	1	Inboard Yoke
4	118-2600-16	2	Spring Pin
5	118-2600-42	1	Inner Profile
6	118-2600-43	1	Outer Profile
7	118-2600-30	1	Inboard Yoke
8	See Page 139	1	Cutout Clutch
9	118-2600-45	2	Guard Cone
10	118-2600-33	2	Bearing Ring
11	118-2600-46	1	Guard Tube Outer
12	118-2600-47	1	Guard Tube Inner
13	918-0208-2-9	2	Screw
14	918-0208-2-8	1	Decal Outer
15	918-0208-1-10	1	Decal Inner
16	918-0208-2-7	1	Restraint Chain
17	918-0208-1-12	2	Zerk
18	118-2600-36	2	Reinforcing Collar
19	918-0208-2-10	1	Decal
20	118-VM-0006-2600-1	1	Power Shift Transmission Half
21	118-VM-0006-2600-2	1	Planetary Half

INTERMEDIATE PTO DRIVE SHAFT

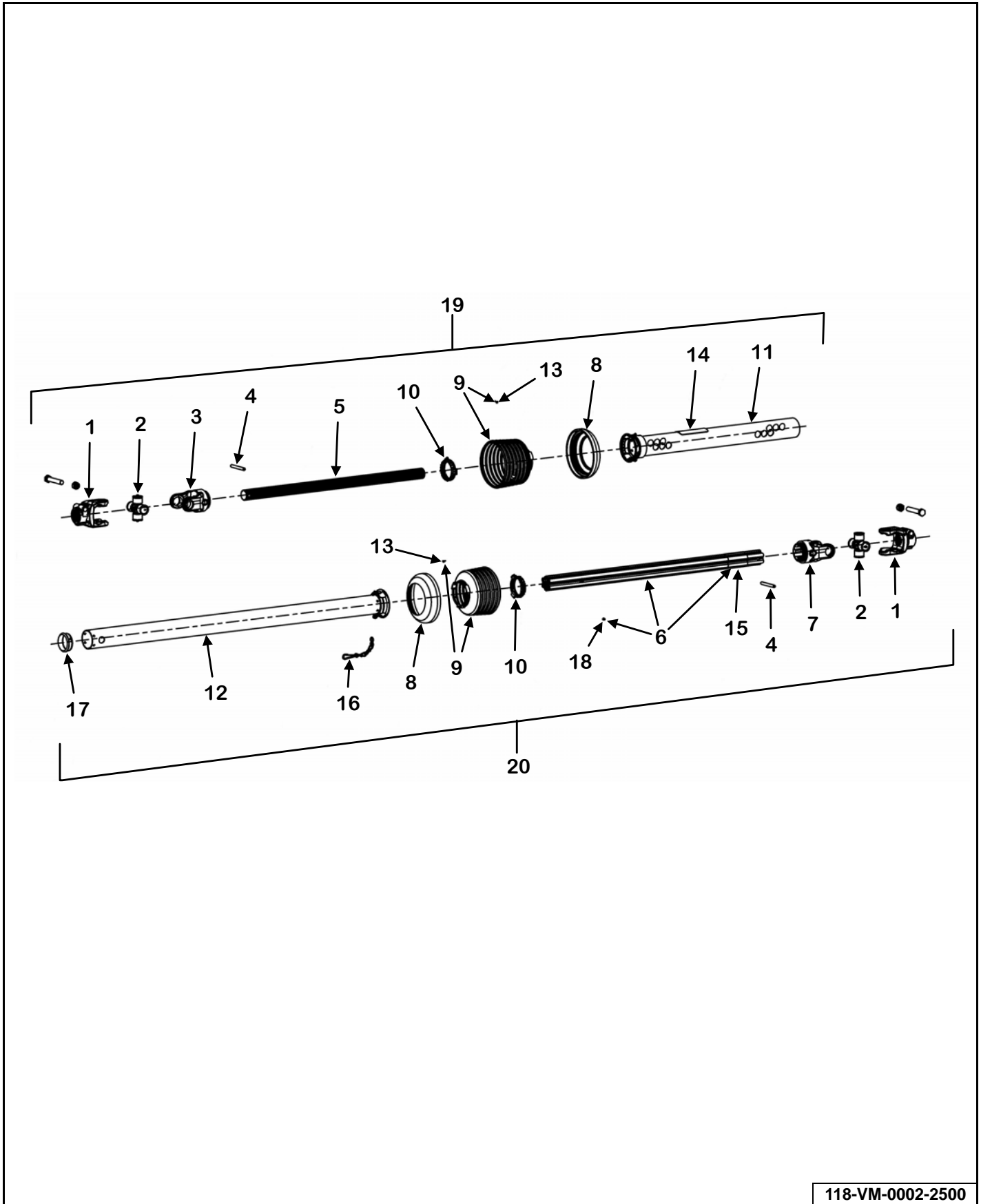

118-VM-0002-2500

KEY	PART NUMBER	QTY	DESCRIPTION
0	118-VM-0002-2500	2	2500 Series PTO Complete
1	118-VM-0010-25-1	2	Yoke
2	118-VM-0010-25-2	2	Cross & Bearing Kit
3	618-0202-2-2	1	Inboard
4	618-0202-2-5	2	Spring Pin
5	118-2500-10	1	Inner Profile
6	118-2500-11	1	Outer Profile
7	618-0201-2-2	1	Inboard Yoke
8	618-0202-2-8	2	Reinforcing Collar
9	118-VM-0024-55-7	2	Guard Cone
10	918-0208-2-4	2	Bearing Ring
11	118-2500-12	1	Guard Tube Outer
12	118-2500-13	1	Guard Tube Inner
13	918-0208-2-9	2	Screw
14	918-0208-2-8	1	Decal Outer
15	918-0208-1-10	1	Decal Inner
16	918-0208-2-7	1	Restraint Chain
17	618-0202-1-10	1	Support Bearing
18	918-0208-1-12	1	Zerk
19	118-VM-0002-2500-1	1	Tractor PTO Half
20	118-VM-0002-2500-2	1	Implement PTO Half

FRONT DOOR CUTOUT CLUTCH

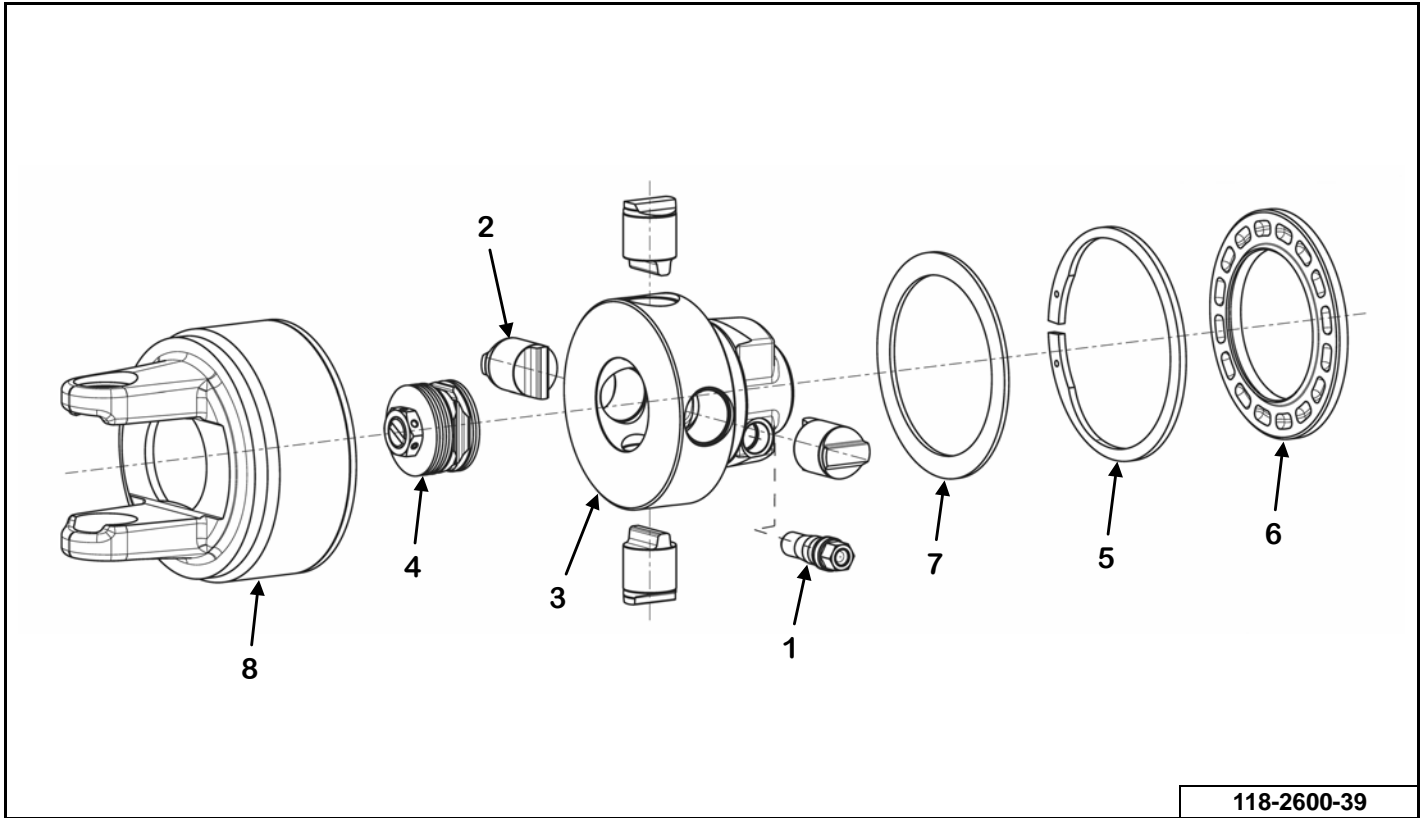

118-2600-39

KEY	PART NUMBER	QTY	DESCRIPTION	MIXER MODEL
0	118-2600-39	1	Cutout Clutch Complete Assembly	1460
1	918-0410-2-1-1	1	Clamp Cone Assembly	1460
2	918-0308-2-2-4	4	Cam	1460
3	118-VM-0021-55-1-1	1	Hub	1460
4	118-2600-39-1	1	Spring Pack	1460
5	118-2600-44-2	1	Retaining Ring	1460
6	918-0208-2-3-7	1	Sealing Ring	1460
7	918-0208-2-3-5	1	Washer	1460
8	118-2600-44-3	1	Housing	1460

SIDE/QUAD DOOR CUTOUT CLUTCH

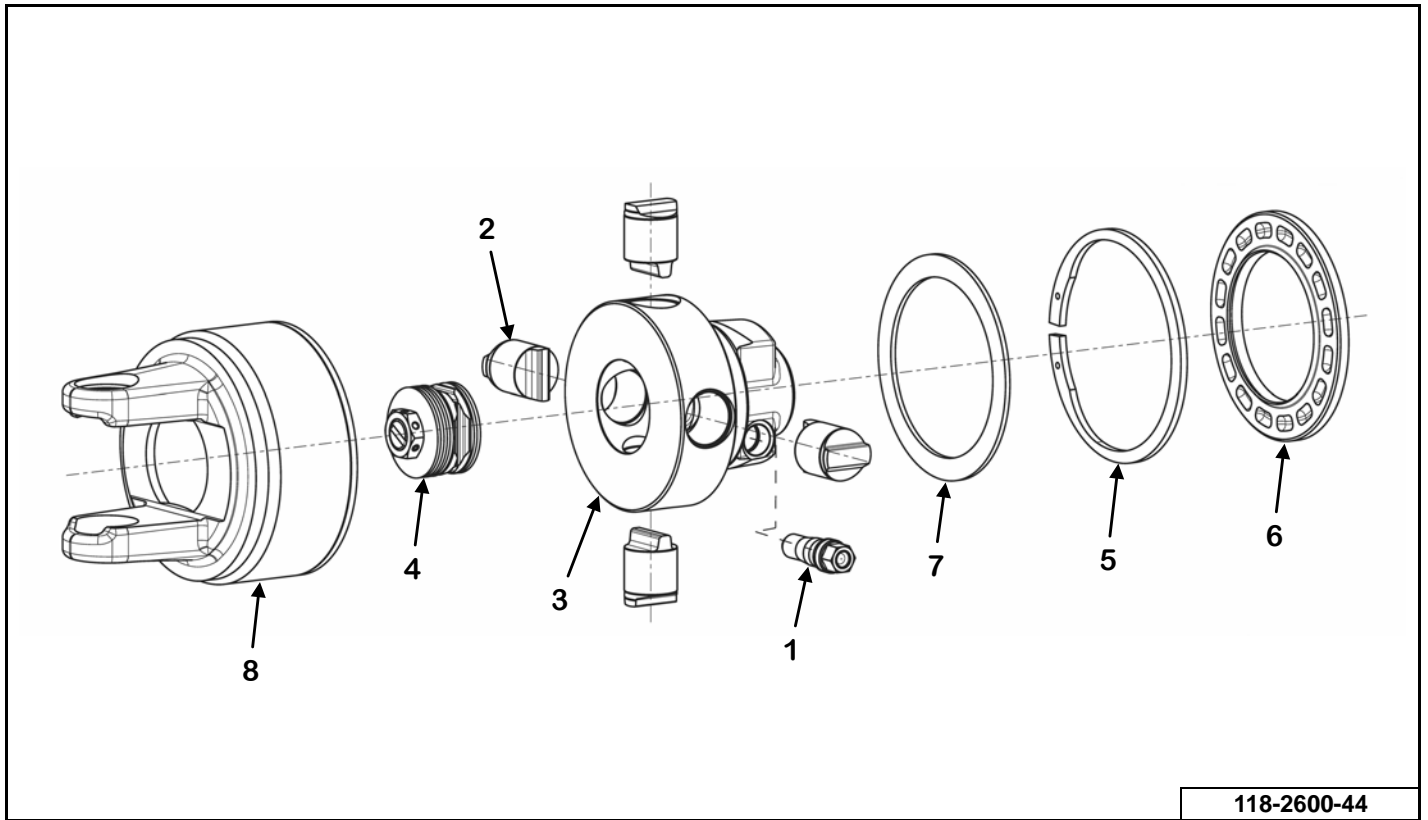

118-2600-44

KEY	PART NUMBER	QTY	DESCRIPTION	MIXER MODEL
0	118-2600-44	1	Cutout Clutch Complete Assembly	1460
1	918-0410-2-1-1	1	Clamp Cone Assembly	1460
2	918-0308-2-2-4	4	Cam	1460
3	118-VM-0021-55-1-1	1	Hub	1460
4	118-2600-44-1	1	Spring Pack	1460
5	118-2600-44-2	1	Retaining Ring	1460
6	918-0208-2-3-7	1	Sealing Ring	1460
7	918-0208-2-3-5	1	Washer	1460
8	118-2600-44-3	1	Housing	1460



10.0 OPTIONAL PARTS

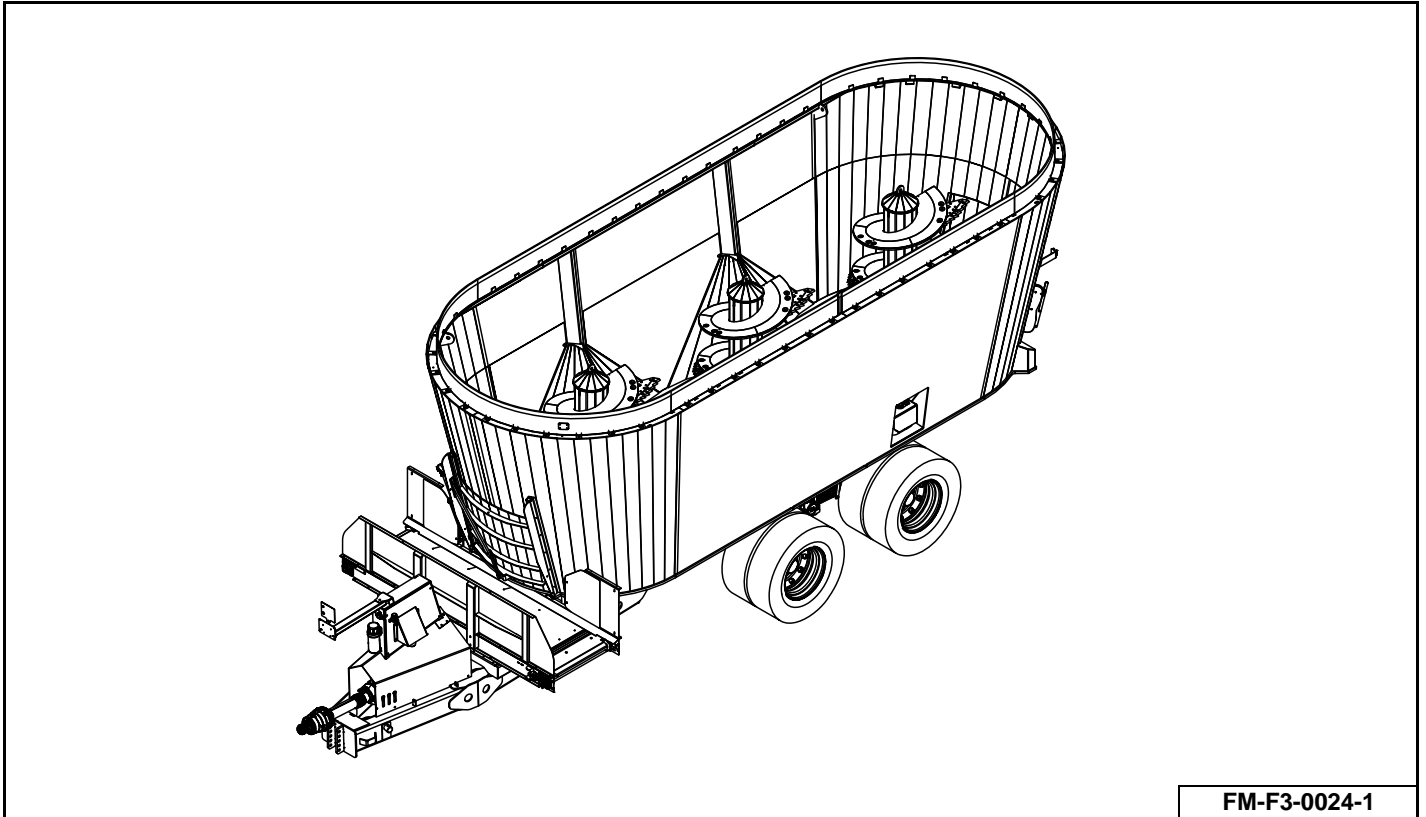

FM-F3-0024-1

KEY	DESCRIPTION	PAGE #
1	CAPACITY EXTENSION	142
2	SIDE DOOR HANGING WEIGHT ASSEMBLY	143
3	REMOTE SCALE MOUNT	144
4	RUBBER SIDE DOOR CHUTE ASSEMBLY	146
5	CONVEYOR HANGING WEIGHT ASSEMBLY	148
6	CONVEYOR DEFLECTOR ASSEMBLY	148
7	POWER MAGNET	150
8	FRONT PLANETARY OIL COOLING SYSTEM	152
	MIDDLE PLANETARY OIL COOLING SYSTEM	154
	REAR PLANETARY OIL COOLING SYSTEM	156
9	QUAD DOOR INDEPENDENT DOOR CONTROL	158

CAPACITY EXTENSION

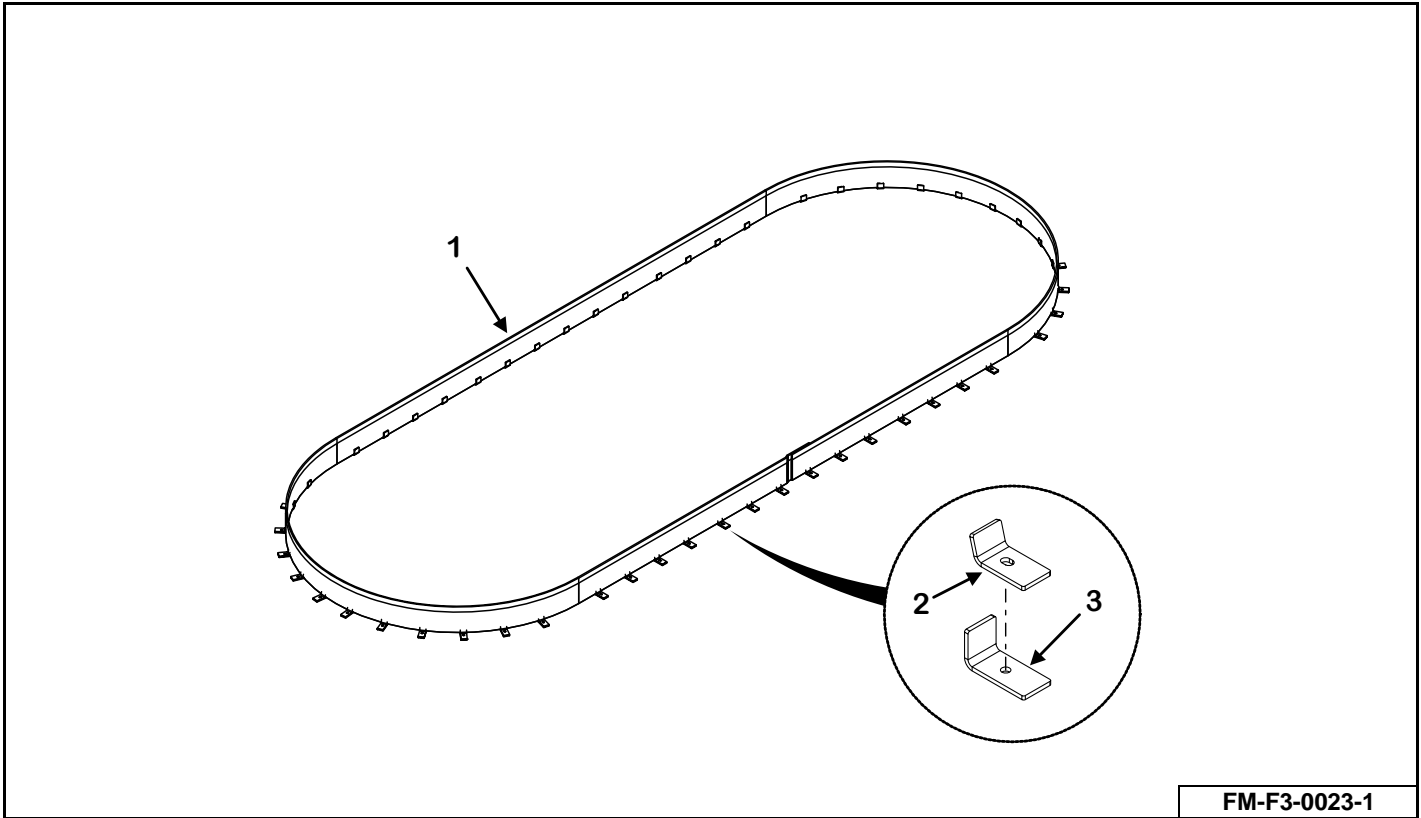

FM-F3-0023-1

KEY	PART NUMBER	QTY	DESCRIPTION	MIXER MODEL
0	F3A-1460-CE-8	1	8" Capacity Extension Assembly	1460
	F3A-1460-CE-10	1	10" Capacity Extension Assembly	1460
	F3A-1460-CE-12	1	12" Capacity Extension Assembly	1460
1	MN11-14-0001	1	8" Capacity Extension .460" x 8" x 62 FT	1460
	MN11-14-0002	1	10" Capacity Extension .460" x 10" x 62 FT	1460
	MN11-14-0007	1	12" Capacity Extension .460" x 12" x 62 FT	1460
	805-0038-Z	4	3/8" Flat Washer	1460
	815-3816-Z	2	3/8"-16 Nylon Insert Lock Nut	1460
	851-3816-1.5Z	2	3/8"-16 x 1-1/2" Grade 5 Machine Bolt	1460
2	MN2-10-0006-9	52	Upper Mount Bracket	1460
3	MN2-10-0006-8	52	Lower Mount Bracket	1460
NS	805-0050-Z	52	1/2" Flat Washer	1460
	814-5013-Z	52	1/2"-13 Indented Lock Nut	1460
	851-5013-1.75Z	24	1/2"-13 x 1-3/4" Grade 5 Machine Bolt	1460
	851-5013-4.5Z	28	1/2"-13 x 4-1/2" Grade 5 Machine Bolt	1460

SIDE DOOR HANGING WEIGHT ASSEMBLY

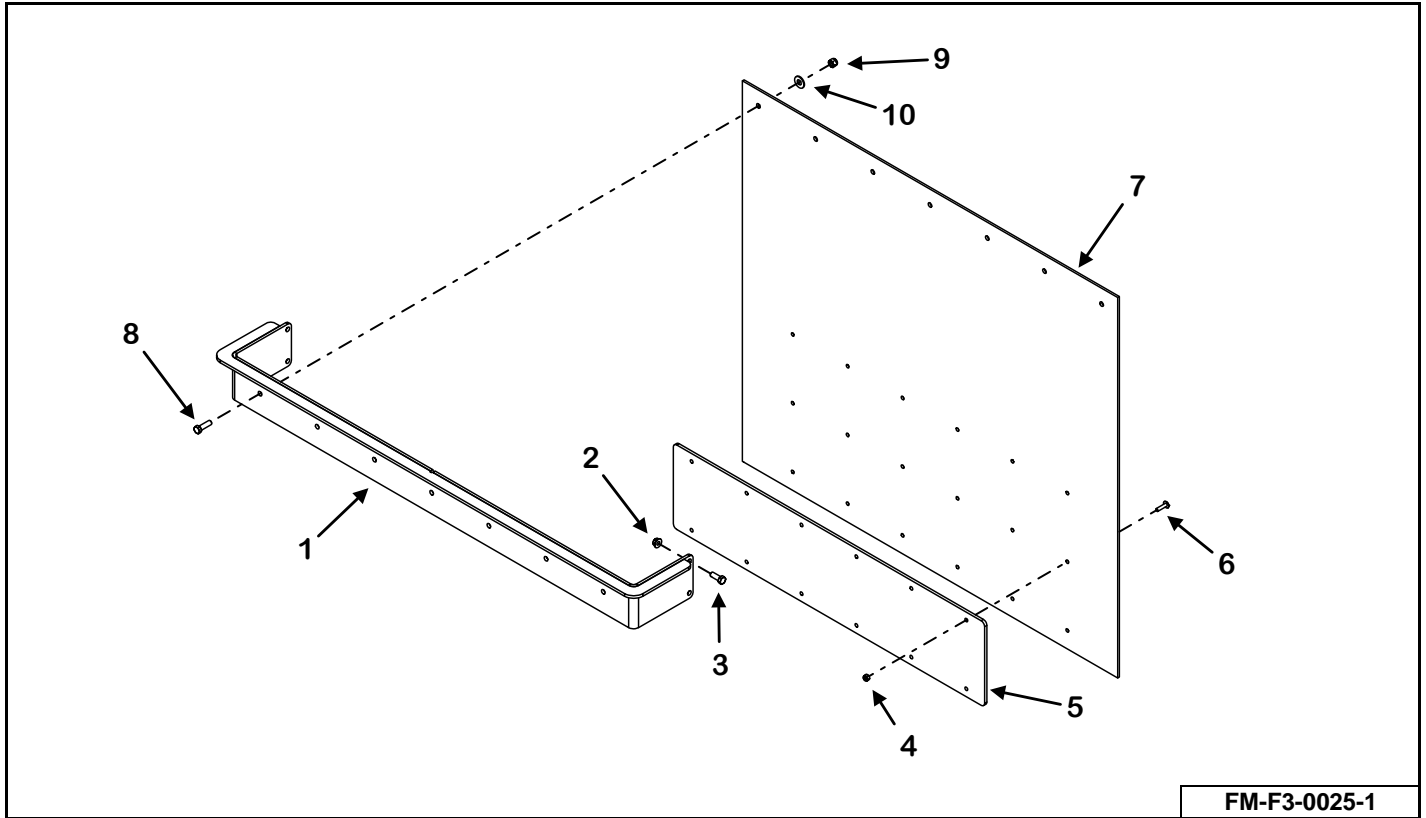

KEY	PART NUMBER	QTY	DESCRIPTION
0	F3A-HDB-43-SL	AR	Clad Tuff 43" Belt Deflector (Front Left / Rear Right Doors)
	F3A-HDB-45-SR	AR	Clad Tuff 45" Belt Deflector (Front Right / Rear Left Doors)
	F3A-HDBS-43-SL	AR	Steel Plate 43" Belt Deflector (Front Left / Rear Right Doors)
	F3A-HDBS-45-SR	AR	Steel Plate 45" Belt Deflector (Front Right / Rear Left Doors)
1	MN11-14-0005-1	1	Door Flap Mount Weldment (Front Left / Rear Right Doors)
	MN11-14-0006-1	1	Door Flap Mount Weldment (Front Right / Rear Left Doors)
2	810-3816-Z	4	3/8"-16 Spin Lock Nut
3	851-3816-1Z	4	3/8"-16 x 1" Hex Cap Screw
4	815-2520-Z	18	1/4"-20 Nylon Insert Lock Nut (Clad Tuff)
	815-2520-Z	12	1/4"-20 Nylon Insert Lock Nut (Steel Plate)
5	M11-10-0031-5	1	Clad Tuff Hanging Weight
	M11-10-0031-4	1	Steel Plate Hanging Weight
6	850-2520-1.25Z	18	1/4"-20 x 1-1/4" Carriage Bolt (Clad Tuff)
	802T-2520-1Z	12	1/4"-20 x 1" Truss Head Machine Screw (Steel Plate)
7	M11-10-0031-3	1	Door Flap Belt
8	851-3816-1.25Z	7	3/8"-16 x 1-1/4" Hex Cap Screw
9	815-3816-Z	7	3/8"-16 Nylon Insert Lock Nut
10	805-0038-Z	7	3/8" Flat Washer

REMOTE SCALE MOUNT

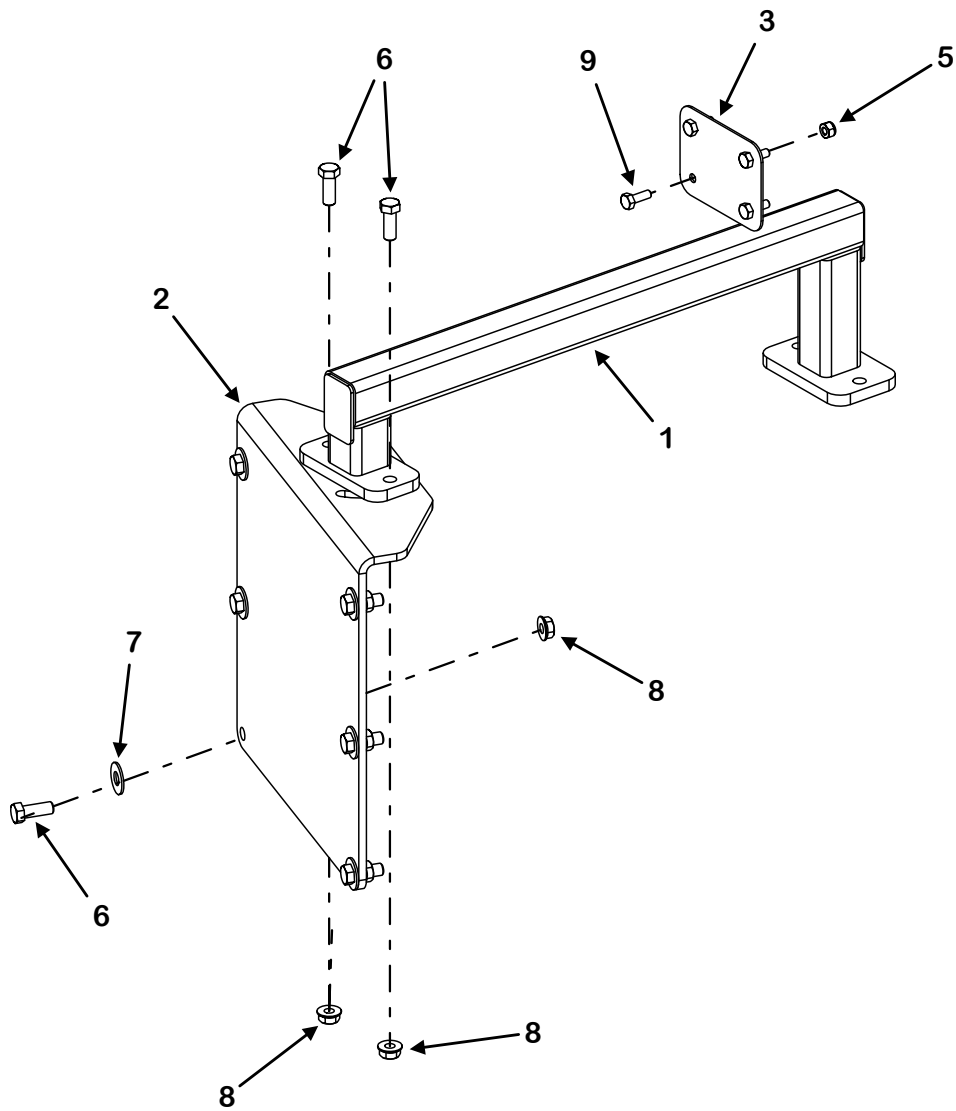

FM-ML-0043-1

KEY	PART NUMBER	QTY	DESCRIPTION	MIXER MODEL
0	VMSCM-405180	1	Remote Display Kit RD400 With TR Kit & 33' Cable/Visor	1460
	VMSCM-405200	1	Remote Display Kit RD400 With 33' Cable/Visor	1460
	VMSCM-407227	1	Remote Display Kit RD250 With 25' Cable	1460
1	M9-1-10-0001	1	Remote Scale Mount Bracket Weldment	1460
2	M9-1-10-0002	1	Remote Scale Mount Bracket	1460
3	M9-1-10-0003	1	Remote Scale Mount Belt Gusset	1460
4	58-0010-405180	1	RD4000 Remote Display Kit W/TR-33' Cable/Visor	1460
	58-0010-405200	1	RD4000 Remote Display Kit W/33' Cable/Visor	1460
5	815-2520-Z	4	1/4"-20 Nylon Insert Lock Nut	1460
6	851-3816-1Z	8	3/8"-16 x 1" Grade 5 Machine Bolt	1460
7	805-0038-Z	6	3/8" Flat Washer	1460
8	810-3816-Z	8	3/8" Spin Lock Nut	1460
9	851-2520-.75Z	4	1/4"-20 x 3/4" Grade 5 Machine Bolt	1460
NS	58-0010-1	1	Remote Cable, Y-Harness For Dual Remote	1460 (Optional)

RUBBER SIDE DOOR CHUTE ASSEMBLY

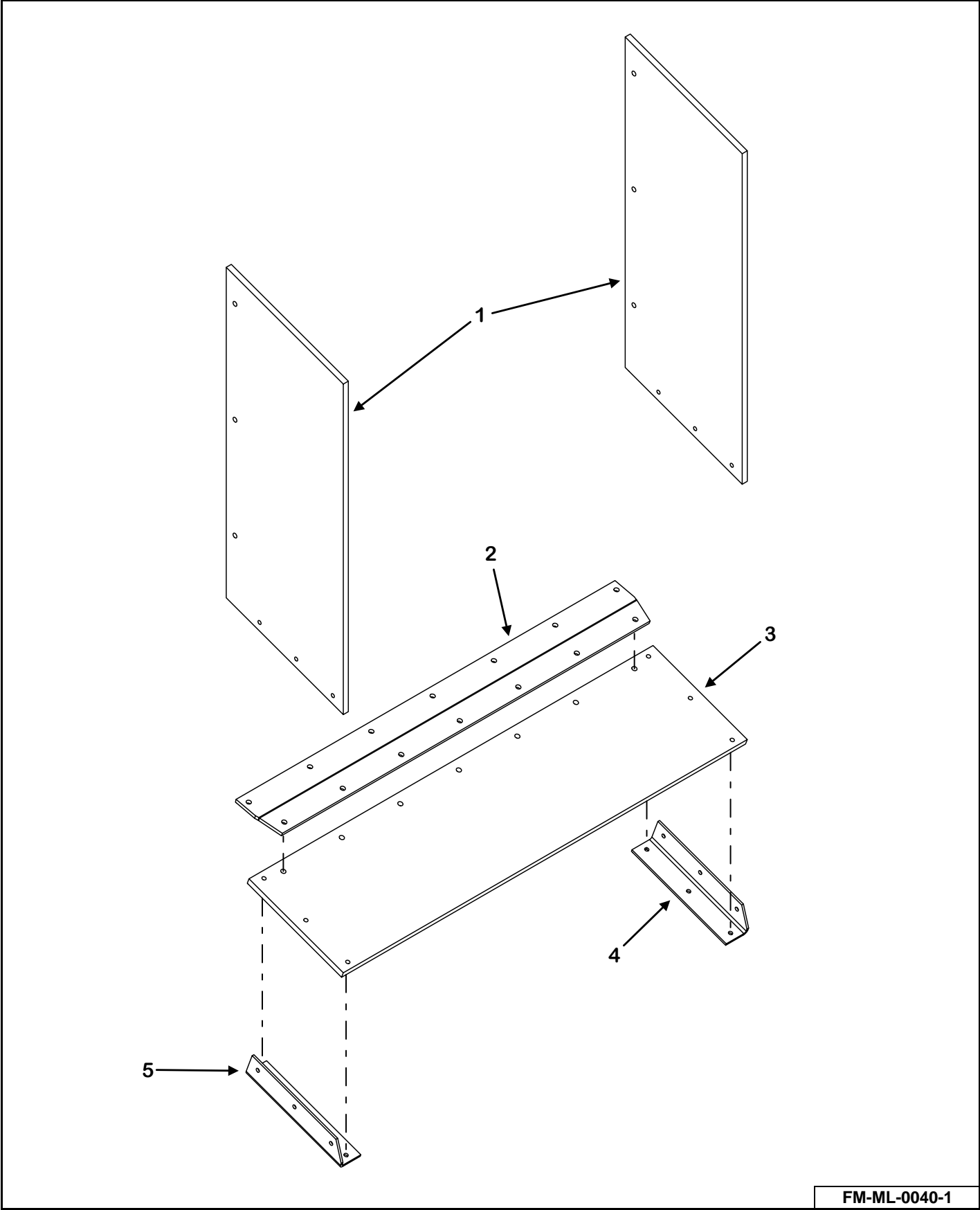

FM-ML-0040-1

KEY	PART NUMBER	QTY	DESCRIPTION	MIXER MODEL
0	F3A-SDBC-12-L	1	12" Front Left & Rear Right Side Door Belt Chute	1460
	F3A-SDBC-12-R	1	12" Front Right & Rear Left Side Door Belt Chute	1460
1	MN11-1-0016-1	2	Chute Side Belt (12" Belt Chute)	1460
2	MN11-1-0016-5	1	Front Left & Rear Right Side Door Belt Chute Mount	1460
	MN11-1-0017-2	1	Front Right & Rear Left Side Door Belt Chute Mount	1460
3	MN11-1-0016-2	1	Front Left & Rear Right Chute Bottom Belt	1460
	MN11-1-0017-1	1	Front Right & Rear Left Chute Bottom Belt	1460
4	MN11-1-0016-4	1	Chute Corner Right Side Bracket (Facing Door)	1460
5	MN11-1-0016-3	1	Chute Corner Left Side Bracket (Facing Door)	1460
NS	802T-2520-1Z	12	1/4"-20 x 1" Truss Head Machine Screw	1460
NS	802T-3118-1.25Z	20	5/16"-18 x 1-1/4" Truss Head Machine Screw	1460
NS	805-0025-Z	12	1/4" Flat Washer	1460
NS	805-0031-Z	13	5/16" Flat Washer	1460
NS	810-3118-Z	7	5/16"-18 Spin Lock Nut	1460
NS	815-2520-Z	12	1/4"-20 Nylon Insert Lock Nut	1460
NS	815-3118-Z	13	5/16"-18 Nylon Insert Lock Nut	1460

CONVEYOR HANGING MAGNET & WEIGHT ASSEMBLY

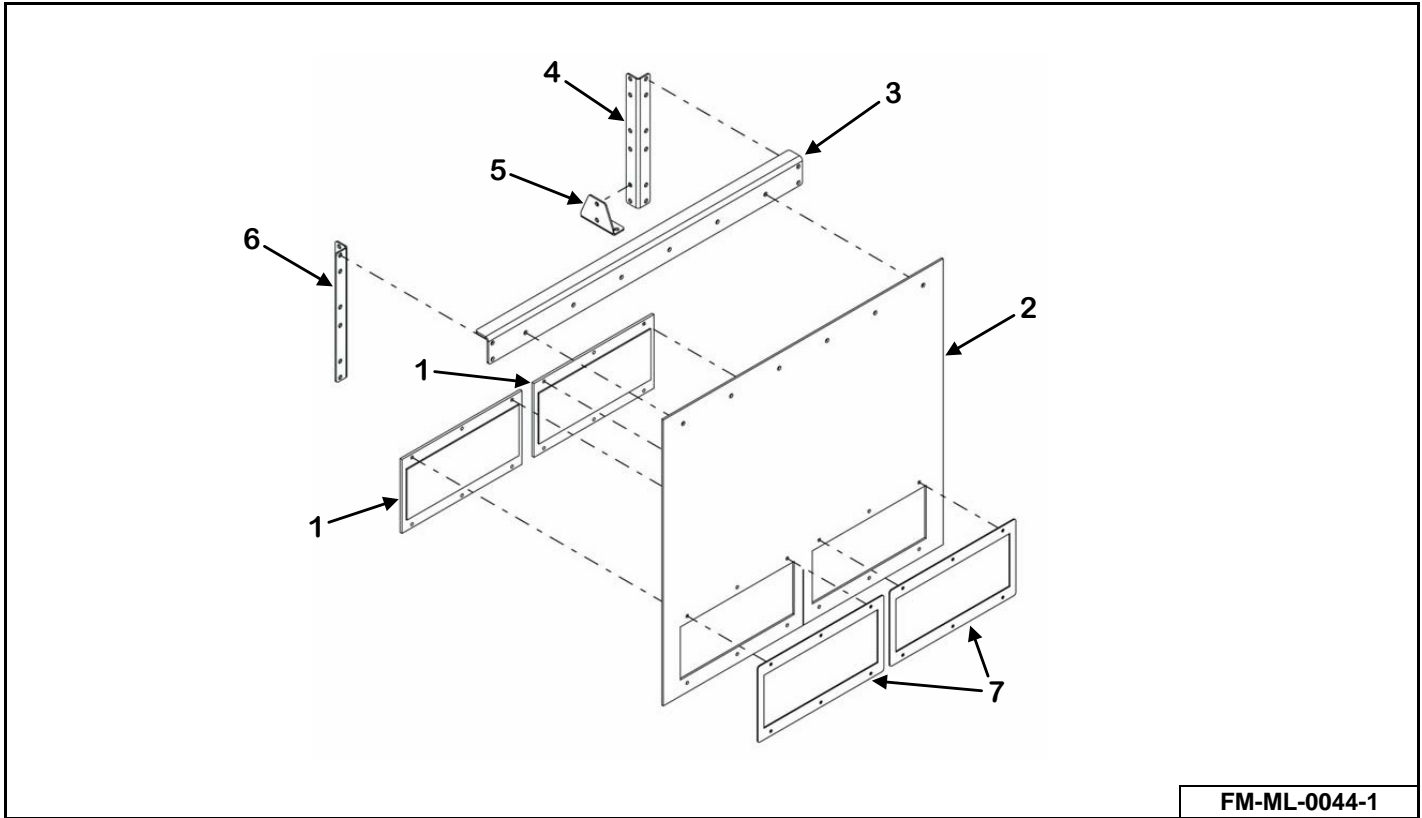

CONVEYOR DEFLECTOR ASSEMBLY

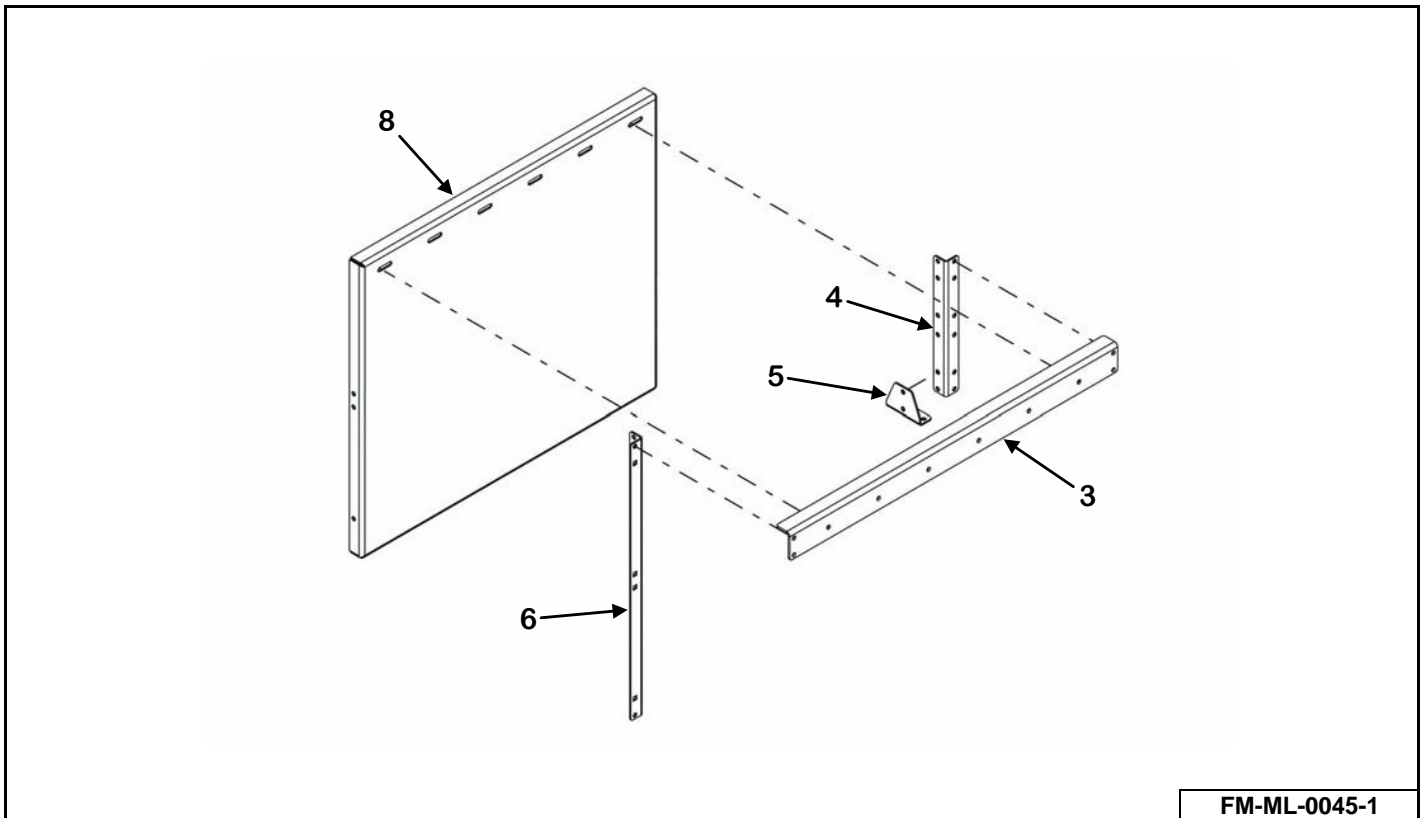

KEY	PART NUMBER	QTY	DESCRIPTION	MIXER MODEL
0	VAML-HMB-F	1	Hanging Magnet Kit For Left / Right Discharge (Front Flat Belt Conveyor)	1460
	VAML-HDB-F	1	Hanging Weight Kit For Left/Right Discharge (Front Flat Belt Conveyor)	1460
	VAML-DBD-F	1	Deflector Kit For Left/Right Discharge (Front Flat Belt Conveyor)	1460
1	M11-1-0004	2	15" Hanging Magnet	1460
	M11-1-0026	2	15" Hanging Weight Plate	1460
2	M11-1-0003-4	1	Magnet Belting	1460
3	M11-1-0003-1	1	Hanging Magnet Mount (Front Flat Belt Conveyor)	1460
4	M11-1-0003-2	1	Magnet Mount Rear Support Upright (Front Flat Belt Conveyor)	1460
5	M11-1-0003-3	1	Magnet Support Mount	1460
6	M11-7-0002	1	Magnet Mount Front Support Upright (Front Flat Belt Conveyor)	1460
7	M11-1-0003-4-1	2	Hanging Magnet/Weight Backer Plates	1460
8	M11-1-0003-5	1	Deflector Plate (Belt Conveyor Only)	1460

POWER MAGNET

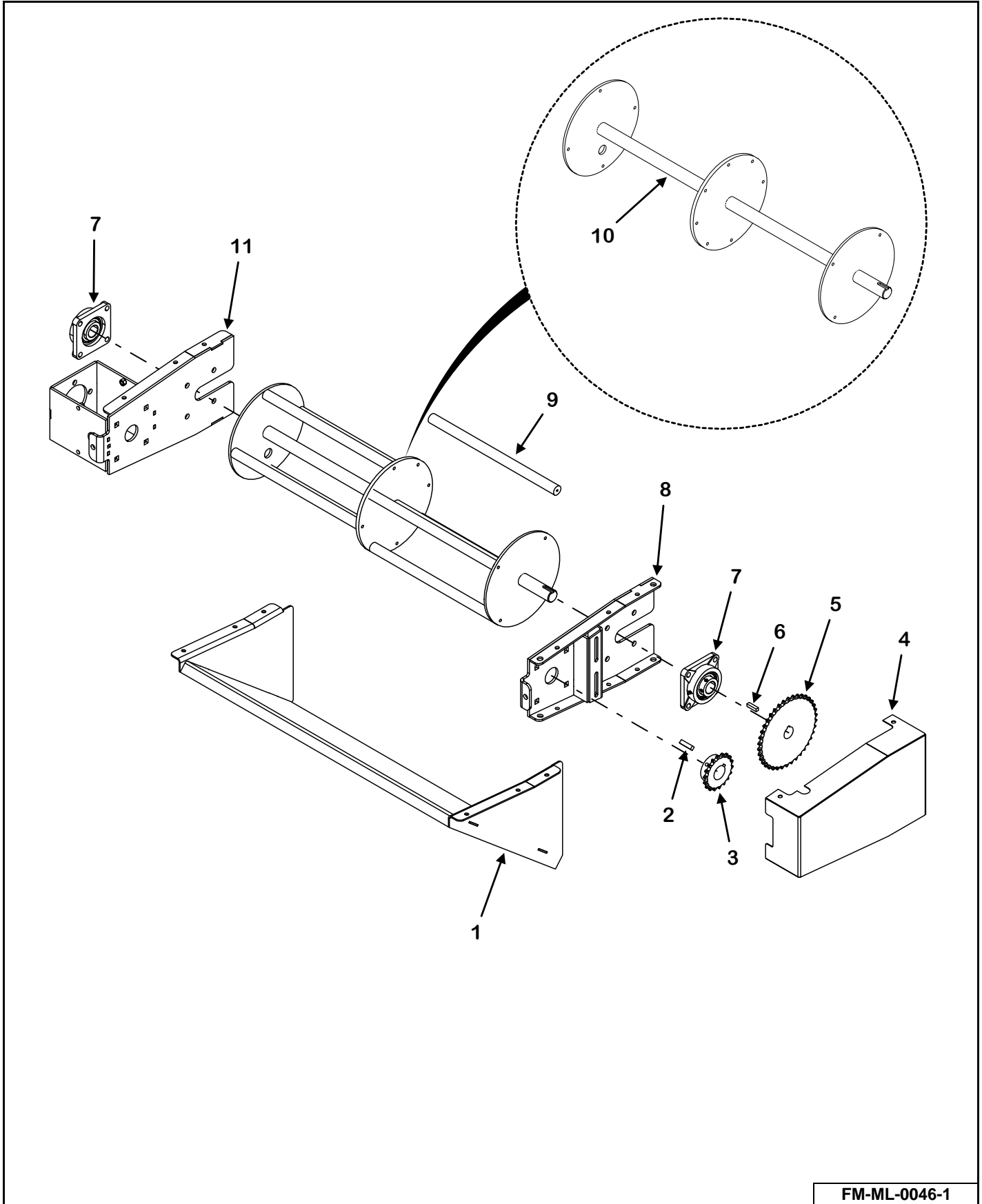

FM-ML-0046-1

KEY	PART NUMBER	QTY	DESCRIPTION	MIXER MODEL
0	VAML-PRM-FDI- KIT	1	Medium/Large Family Power Magnet Flat Conveyor Kit	1460
1	M3-1-10-0028	1	Deflector Weldment	1460
2	35-0010	1	3/8" x 3/8" x 1-1/2" Square Key	1460
3	110-50B18-1.5-1	1	50B18 1-1/2" Sprocket	1460
4	M3-1-10-0029-1	1	Shield Weldment	1460
5	110-50B38-1.25-1	1	50B38 1-1/4" Sprocket	1460
6	35-0030-H	1	5/16" x 5/16" x 1-1/4" Square Key	1460
7	14-0101	2	1-1/4" 4-Bolt Bearing	1460
8	M3-1-10-0025	1	Bearing Mount Weldment	1460
9	M3-1-8-0020-4	8	Magnet Tube	1460
10	M3-1-8-0020-1	1	Spinner Weldment	1460
11	M3-1-10-0026	1	Motor Mount Weldment	1460

FRONT PLANETARY OIL COOLING SYSTEM

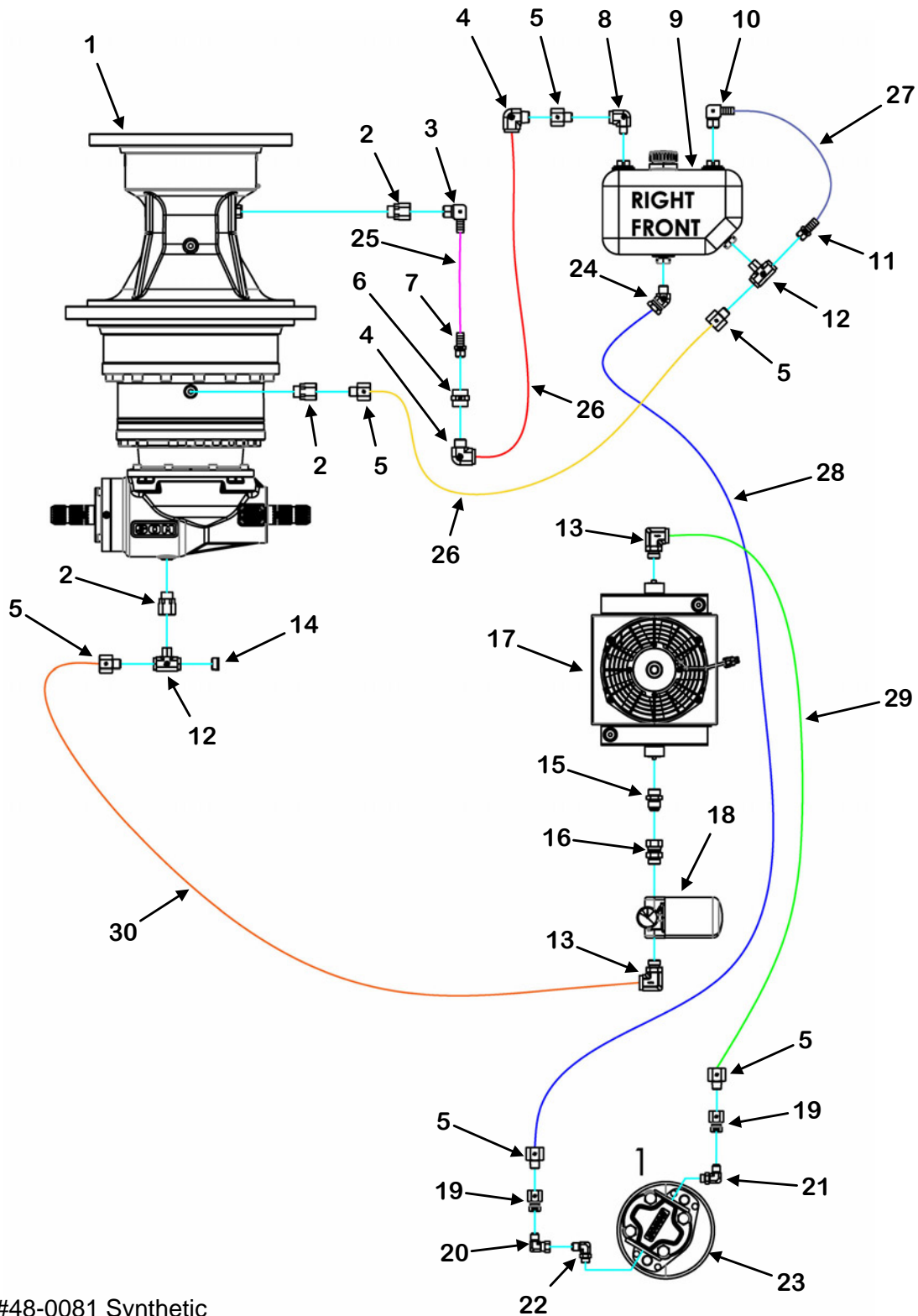

Use #48-0081 Synthetic ISO220 or Equivalent For Planetary Gearboxes.

FM-F3-0019-1

KEY	PART NUMBER	QTY	DESCRIPTION	MIXER MODEL
1	See Page 122	1	3003 Series Planetary Gearbox	1460
2	155-PB08-08	3	Straight Adapter	1460
3	55-0406	1	90° 1/2" Hose Barb	1460
4	55-0082	2	90° Fitting	1460
5	155-5405-08-12	6	Straight Adapter	1460
6	55-0039	1	Straight Adapter	1460
7	55-0410	1	Straight 1/2" Hose Barb	1460
8	155-5502-06-08	1	90° Fitting	1460
9	952-0005	1	2-1/2 Gallon Plastic Tank With Vented Cap	1460
10	55-0401	1	90° 3/8" Hose Barb	1460
11	55-0412	1	Straight 3/8" Hose Barb	1460
12	155-5604-08-08-08	2	Tee	1460
13	955-3708	2	90° Fitting	1460
14	155-5406-HP-08	1	Hex Plug	1460
15	155-6400-12-12	1	Straight Coupler	1460
16	155-6402-12-12	1	Straight Coupler	1460
17	155-OC-D10-1	1	Heat Exchanger	1460
18	55-0376	1	Filter Assembly	1460
	55-0376-1	1	Filter Element	1460
	55-0376-2	1	Visual Indicator	1460
19	155-6506-8-8	2	Straight Coupler	1460
20	155-6500-08-08	1	90° Fitting	1460
21	155-6801-08-06	1	90° Fitting	1460
22	155-6801-08-08	1	90° Fitting	1460
23	55-0440	1	Honor 1A Series Gear Pump	1460
24	155-1503-08-12	1	45° Fitting	1460
25	155-08-6-13	1	1/2" x 13" Hose	1460
26	155-12-82-1	2	3/4" x 82" Hose Assembly	1460
27	155-06-7-15	1	3/8" x 15" Clear PVC Hose	1460
28	155-12-196-1	1	3/4" x 196" Hose Assembly	1460
29	155-12-163-1	1	3/4" x 163" Hose Assembly	1460
30	155-12-38-3	1	3/4" x 38" Hose Assembly	1460

MIDDLE PLANETARY OIL COOLING SYSTEM

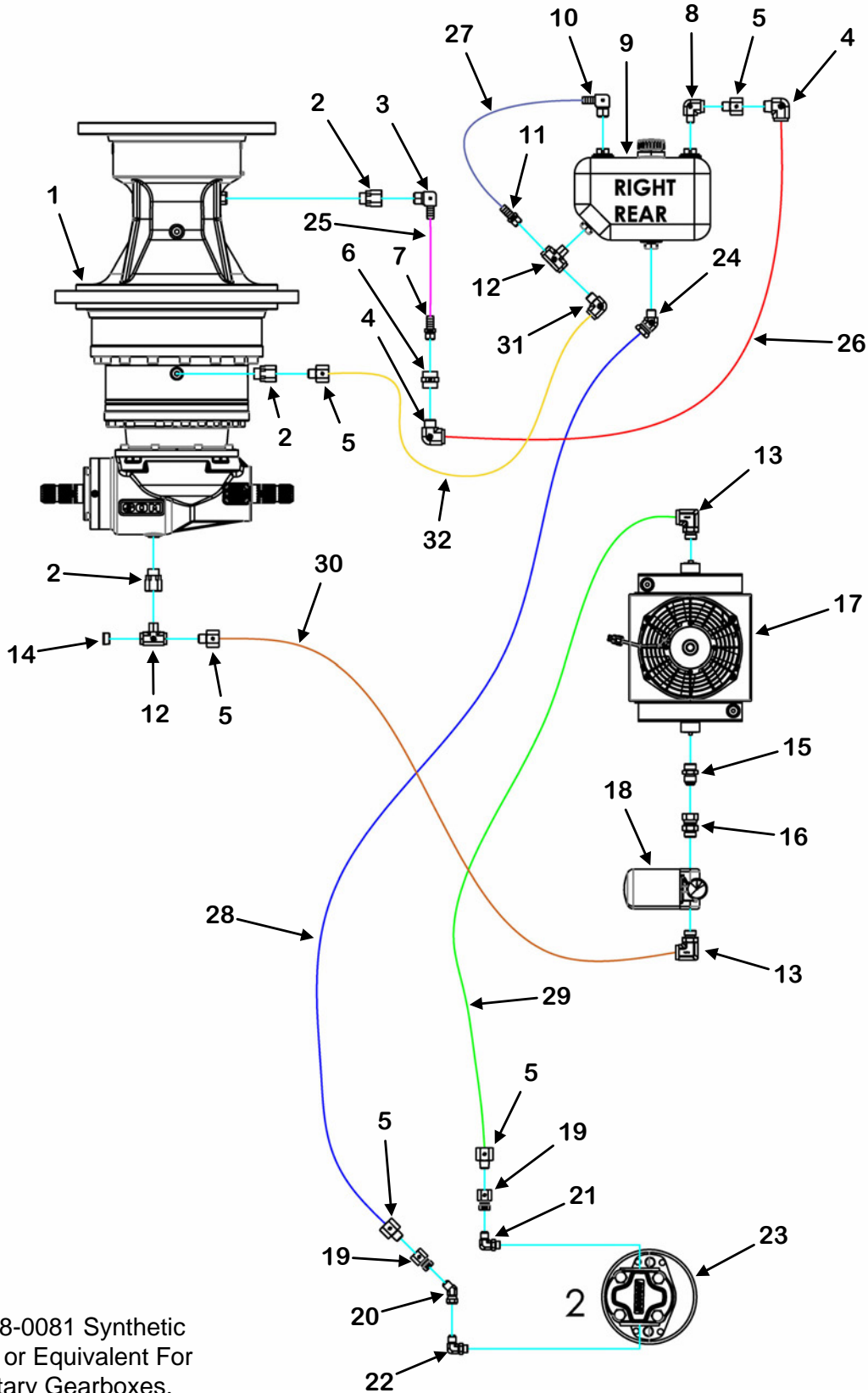

FM-F3-0020-1

KEY	PART NUMBER	QTY	DESCRIPTION	MIXER MODEL
1	See Page 122	1	3003 Series Planetary Gearbox	1460
2	155-PB08-08	3	Straight Adapter	1460
3	55-0406	1	90° 1/2" Hose Barb	1460
4	55-0082	2	90° Fitting	1460
5	155-5405-08-12	5	Straight Adapter	1460
6	55-0039	1	Straight Adapter	1460
7	55-0410	1	Straight 1/2" Hose Barb	1460
8	155-5502-06-08	1	90° Fitting	1460
9	952-0005	1	2-1/2 Gallon Plastic Tank With Vented Cap	1460
10	55-0401	1	90° 3/8" Hose Barb	1460
11	55-0412	1	Straight 3/8" Hose Barb	1460
12	155-5604-08-08-08	2	Tee	1460
13	955-3708	2	90° Fitting	1460
14	155-5406-HP-08	1	Hex Plug	1460
15	155-6400-12-12	1	Straight Coupler	1460
16	155-6402-12-12	1	Straight Coupler	1460
17	155-OC-D10-1	1	Heat Exchanger	1460
18	55-0376	1	Filter Assembly	1460
	55-0376-1	1	Filter Element	1460
	55-0376-2	1	Visual Indicator	1460
19	155-6506-8-8	2	Straight Coupler	1460
20	155-6502-08-08	1	45° Fitting	1460
21	155-6801-08-06	1	90° Fitting	1460
22	155-6801-08-08	1	90° Fitting	1460
23	55-0440	1	Honor 1A Series Gear Pump	1460
24	155-1503-08-12	1	45° Fitting	1460
25	155-08-6-13	1	1/2" x 13" Hose	1460
26	155-12-110-1	1	3/4" x 110" Hose Assembly	1460
27	155-06-7-15	1	3/8" x 15" Clear PVC Hose	1460
28	155-12-95-2	1	3/4" x 95" Hose Assembly	1460
29	155-12-46-1	1	3/4" x 46" Hose Assembly	1460
30	155-12-71-1	1	3/4" x 71" Hose Assembly	1460
31	155-5502-08-12	1	90° Fitting	1460
32	155-12-100-3	1	3/4" x 100" Hose Assembly	1460

REAR PLANETARY OIL COOLING SYSTEM

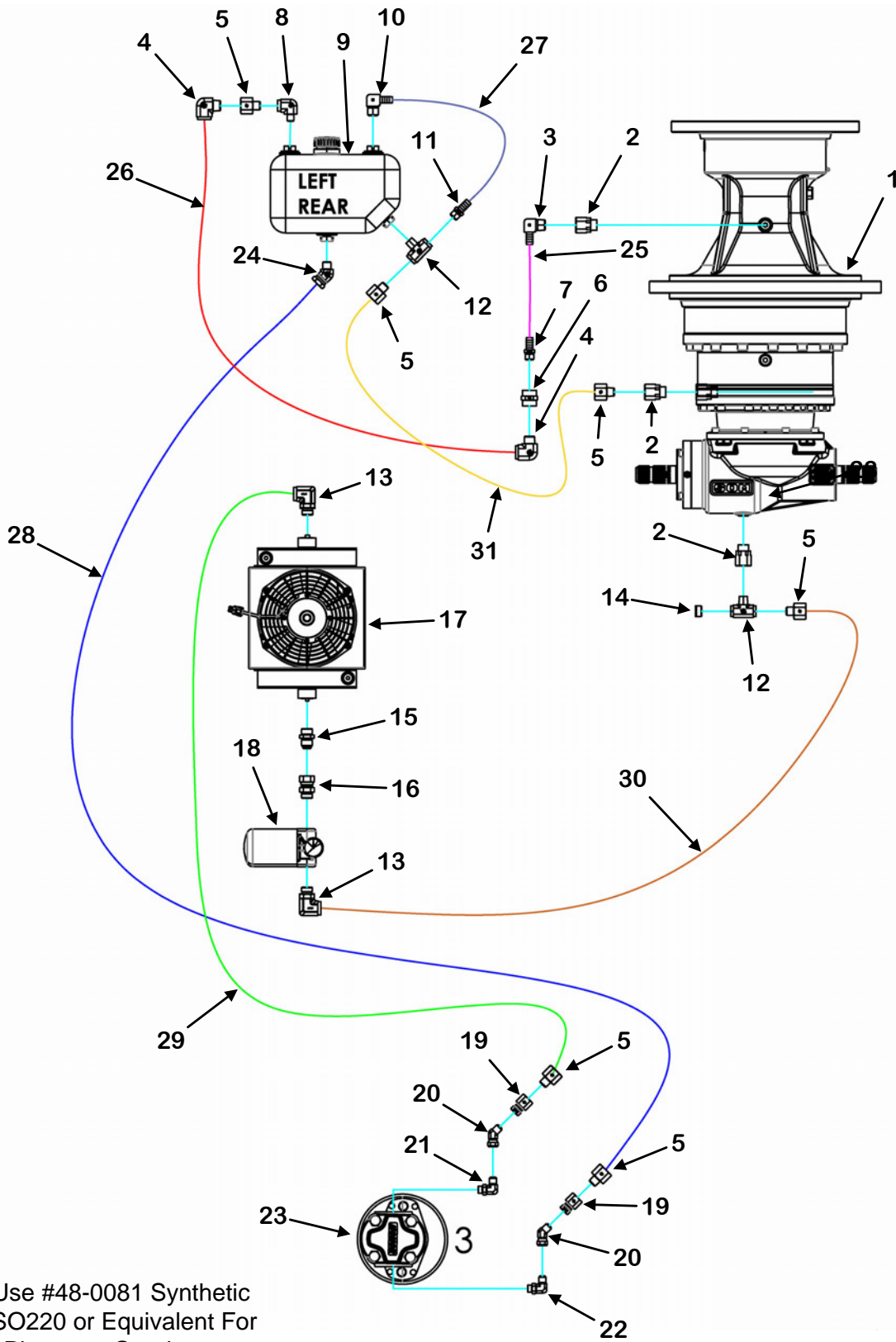

Use #48-0081 Synthetic ISO220 or Equivalent For Planetary Gearboxes.

FM-F3-0021-1

KEY	PART NUMBER	QTY	DESCRIPTION	MIXER MODEL
1	See Page 122	1	3003 Series Planetary Gearbox	1460
2	155-PB08-08	3	Straight Adapter	1460
3	55-0406	1	90° 1/2" Hose Barb	1460
4	55-0082	2	90° Fitting	1460
5	155-5405-08-12	6	Straight Adapter	1460
6	55-0039	1	Straight Adapter	1460
7	55-0410	1	Straight 1/2" Hose Barb	1460
8	155-5502-06-08	1	90° Fitting	1460
9	952-0005	1	2-1/2 Gallon Plastic Tank With Vented Cap	1460
10	55-0401	1	90° 3/8" Hose Barb	1460
11	55-0412	1	Straight 3/8" Hose Barb	1460
12	155-5604-08-08-08	2	Tee	1460
13	955-3708	2	90° Fitting	1460
14	155-5406-HP-08	1	Hex Plug	1460
15	155-6400-12-12	1	Straight Coupler	1460
16	155-6402-12-12	1	Straight Coupler	1460
17	155-OC-D10-1	1	Heat Exchanger	1460
18	55-0376	1	Filter Assembly	1460
	55-0376-1	1	Filter Element	1460
	55-0376-2	1	Visual Indicator	1460
19	155-6506-8-8	2	Straight Coupler	1460
20	155-6502-08-08	2	45° Fitting	1460
21	155-6801-08-06	1	90° Fitting	1460
22	155-6801-08-08	1	90° Fitting	1460
23	55-0440	1	Honor 1A Series Gear Pump	1460
24	155-1503-08-12	1	45° Fitting	1460
25	155-08-6-13	1	1/2" x 13" Hose	1460
26	155-12-106-1	1	3/4" x 106" Hose Assembly	1460
27	155-06-7-15	1	3/8" x 15" Clear PVC Hose	1460
28	155-12-108-3	1	3/4" x 108" Hose Assembly	1460
29	155-12-49-1	1	3/4" x 49" Hose Assembly	1460
30	155-12-38-3	1	3/4" x 38" Hose Assembly	1460
31	155-12-84-2	1	3/4" x 84" Hose Assembly	1460

QUAD DOOR INDEPENDENT DOOR CONTROLS

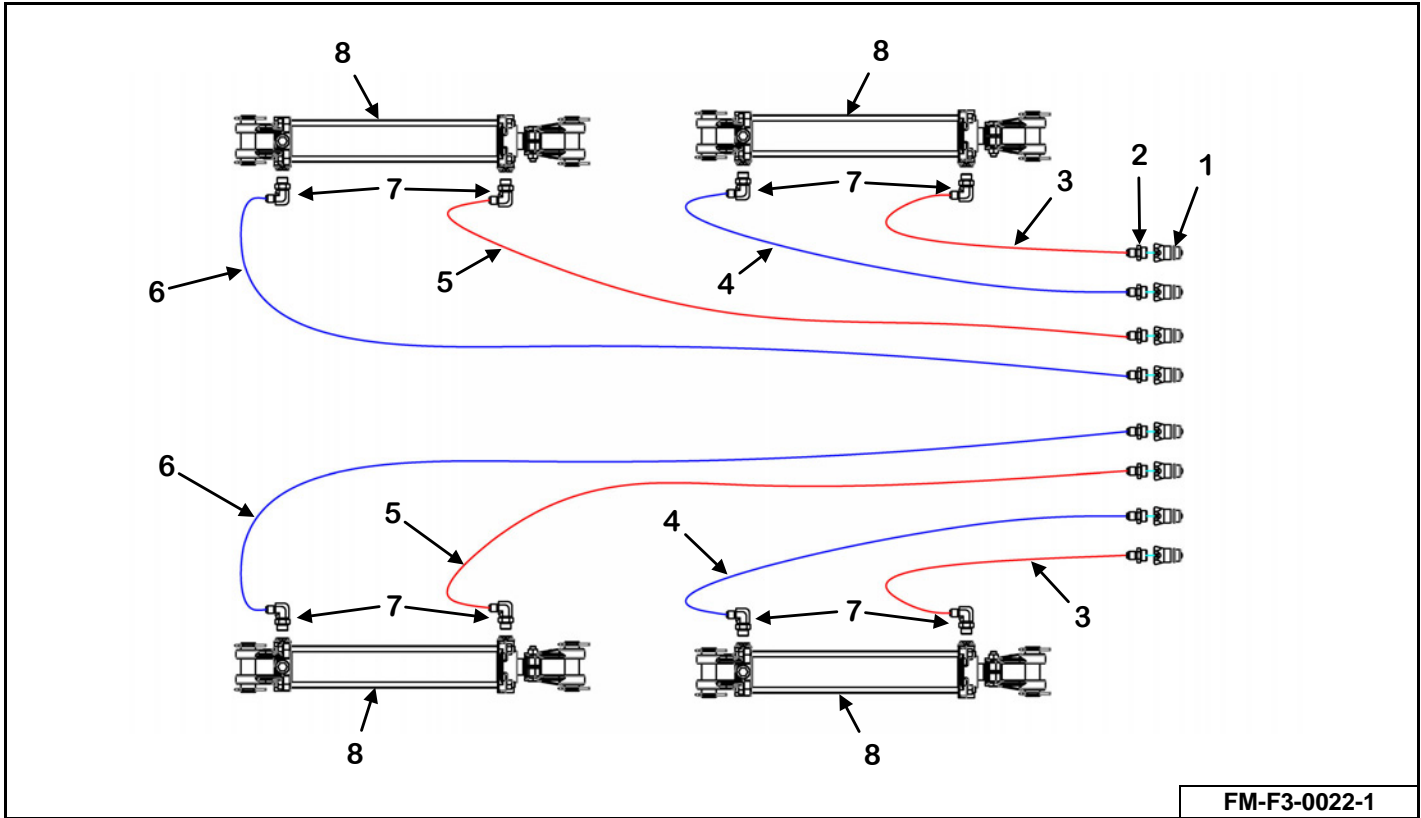

KEY	PART NUMBER	QTY	DESCRIPTION	MIXER MODEL
0	F3A-IDC-Q	1	Independent Door Control	1460
1	155-8010-15	8	#8 ORB Male Tip 1/2" Body Size	1460
2	155-6400-6-8	8	#6 JIC Male, #8 ORB Male Straight Connector	1460
3	155-04R17-240-1	2	1/4" x 240" Hose Assembly	1460
4	155-04R17-227-1	2	1/4" x 227" Hose Assembly	1460
5	155-04R17-459-1	2	1/4" x 459" Hose Assembly	1460
6	155-04R17-444-1	2	1/4" x 444" Hose Assembly	1460
7	155-6801-6-8	8	#6 JIC Male, #8 ORB Male Adjustable 90°	1460
8	See Page 106	1	2-1/2" x 12" x 1-1/8" Hydraulic Cylinder	1460

11.0 SPECIFICATIONS

1460 DIMENSIONS	
	1460
Overall Length - Side Door / Front Door	398" / 398"
Mixing Chamber Length	311.2"
Overall Height - Tire Option Used	315/80R-22.5
Overall Height - Base Machine	138.7"
Overall Height - 8" Belt Extensions	144.5"
Overall Height - 12" Belt Extensions	148.5"
Tread Width	110.5"
Transport Width - Front Chain Conveyor	119.2"
Max Discharge Reach - Front Chain Cross Conveyor - Flat	12.25" (Max)
Max Discharge Reach - Front Belt Cross Conveyor - Flat	6.25" (Max)
Max Discharge Reach - Side Slide Tray (Quad Door)	0"
Max Discharge Reach - Side Belt Extension (Quad Door)	6"
Max Discharge Height - Front Cross Conveyor - Flat Chain/Belt	40.25"
Max Discharge Height - Side Belt Extension	24.65"

1460 SPECIFICATIONS	
	1460
Mixing Capacity - No Extension	1460 Cu. Ft.
Mixing Capacity - 8" Extensions	1580 Cu. Ft.
Mixing Capacity - 12" Extensions	1659 Cu. Ft.
Unit Weight - Front Discharge - lbs (Option Sensitive)	N/A
Unit Weight - Side Discharge - lbs (Option Sensitive)	N/A
Maximum Net Load - lbs	52,000
Auger Qty.	3
Auger Diameter	93"
Auger Speed - Standard / High Speed	22 / 39 RPM
Auger - Flighting Thickness	3/4"
Auger - Overlap	6"
Auger - Knives - Adjustable - Per Auger	7
Planetary Drive	Straight-Drive Comer 3003
Transmission Drive	2-Speed Power Shift (Wireless Shift)
PTO Drive	1-3/4" 1000 RPM
Drive Protection	Torque-Disconnect
Discharge Door Opening - Front	46" x 40"
Discharge Door Opening - Side	42" x 40"
Discharge Door Opening - Rear	46" x 40"
Discharge Conveyor Width - Front Chain/Belt	36"
Discharge Flat Front Shiftable Chain Cross Conveyor Length	119"
Discharge Flat Front Shiftable Belt Cross Conveyor Length	107"
Tub / Trailer - Floor Thickness	1"
Tub / Trailer - Sidewall Thickness	3/8"
Tub / Trailer - Trailer or Subframe	Tandem Duals
Tub / Trailer - Spindle Diameter	5-1/2"
Tub / Trailer - Scale System	8-Point
Tongue Weight - % Gross	~10%
Tractor Requirement - PTO HP	250
Empty Weight - lbs	43,500

FEATURES	
	1460
Stainless Lined, High Wear Auger Flighting	STD
Knives-Adjustable - 7	STD
Articulating Ag Hitch	STD
Hay Stops	STD
Platform	STD
Jack Stand	STD
Torque Disconnect PTO's	STD
Power Shift Transmission (Electric Shift)	STD
Straight Drive	N/A
Heavy-Duty Gearboxes	STD

OPTIONS	
	1460
Planetary Cooling System & Filtration	OPT
54" Stainless Side Liners	OPT
Safety Chain / SMV	OPT
Capacity / Belt Extension (8" or 12")	OPT
Incline Conveyors (Flat Front Conveyor Only)	OPT
Scale System / Remote Indicators	OPT
Additional Knife Kits - 10	OPT
Magnets	OPT



**Manufactured by:
Meyer Manufacturing
Corporation**

674 W. Business Cty Rd A

Dorchester, WI 54425

Phone. 1-800-325-9103

Fax: 715-654-5513

Email: parts@meyermfg.com

Website: www.meyermfg.com