

PB-MIXER-L-19



FORMULA MIXER

F815 • F815P • F815C • F1015P • F1015C •
F1015 • F1215

Owner/Operator's Manual
&
Parts Book

Starting 2019 Model Year



8/13/2024

1.0 IMPORTANT INFORMATION

The mixer serial number plate is located on the front left hand side of the mixing tub.

The trailer serial number plate is located on the left hand side of the trailer hitch.

Please enter the model, serial number and additional information in the space provided for future reference.



**Mixer Body
Serial Number**

Model No. _____

Mixer Serial No. _____

Trailer Serial No. _____

Date of Purchase _____

Dealership _____

Dealership Phone No. _____



**Trailer
Serial Number**

Always use your serial number when requesting information or when ordering parts.

HOW TO READ THE SERIAL NUMBER

MIXER

EXAMPLE: 19VM0815201

Model Year / Vertical Mixer / Model / Sequence Of Build



19



VM



0815



201

TRAILER

EXAMPLE: VMT19201

Vertical Mixer Trailer / Model Year / Sequence Of Build



VMT



19



201

Meyer Manufacturing Corporation
674 W. Business Cty Rd A
Dorchester, WI 54425
Phone: 1-800-325-9103
Fax: 715-654-5513
Email: parts@meyermfg.com
Website: www.meyermfg.com



2.0 PRE-DELIVERY & DELIVERY CHECK LIST

MEYER MANUFACTURING CORPORATION

Phone: 715-654-5132 • Toll-Free: 1-800-325-9103 • P.O. Box 405 • Dorchester, WI 54425

This Pre-Delivery & Delivery Check List must be gone through by the Selling Party and the Customer to validate the Owner's Registration Form.

PRE-DELIVERY CHECK LIST

After the new Meyer Mixer has been completely set-up, check to be certain it is in correct running order before delivering it to the customer.

The following is a list of points to inspect:

Check off each item as you have made the proper adjustments and found the item operating satisfactorily. Any adjustments made, MUST be according to specifications defined in this manual.

- All shields and guards are in place and securely fastened.
- All PTO shields turn freely.
- All bolts and other fasteners are secure and tight.
- All mechanisms operate trouble free.
- All grease fittings have been lubricated, gear boxes filled to proper levels and all roller chains are oiled. Refer to 8.2 LUBRICATION.
- Conveyor Belt or Chain are at proper tension. Refer to 8.3 ADJUSTMENTS.
- All stop/tail/turn lights work properly.
- All decals are in place and legible.

DELIVERY CHECK LIST

The following check list is an important reminder of valuable information that MUST be passed on to the customer at the time the unit is delivered.

Check off each item as you explain it to the customer.

- Explain to the customer that pre-delivery check list was fully completed.
- Give customer the Owner & Operator's Manual. Instruct to read and completely understand its contents BEFORE attempting to operate the mixer.
- Explain and review with customer the new Meyer implement manufacturer's warranty.
- Show the customer where to find the serial number on the implement.
- Explain and review with the customer the 5.1 SAFETY PRECAUTIONS.
- Explain and review with customer the proper "Start-up and Operating Procedures" sections of this manual.
- Demonstrate the PTO Shaft Locking Device and proper PTO shaft storage. Also, demonstrate proper hydraulic hose storage and tip holder used to keep system clean from contaminants.
- Explain that regular lubrication and proper adjustments are required for continued proper operation and long life of the mixer. Review with the customer the 8.2 LUBRICATION and 8.3 ADJUSTMENTS sections of this manual.
- Explain the importance of conveyor chain or belt tension, and the need to watch and tighten during the break-in period.
- Fully complete this PRE-DELIVERY & DELIVERY CHECK LIST with the customer.



3.0 INTRODUCTION

Congratulations on your purchase of a new Meyer farm equipment product. Undoubtedly you have given much consideration to your purchase and we're proud that you have selected Meyer. Pride in craftsmanship, engineering and customer service have made Meyer products the finest in the farm equipment industry today.

There is no substitute for quality. That is why thousands of people like you have purchased Meyer farm equipment. They felt it was the best equipment to serve their farming needs, now and in years to come. We ask that you follow our policy of "safety first", and we strongly suggest that you read through the "Owner / Operator's Manual & Parts Book" before operating your Meyer farm equipment. Meyer Manufacturing Corporation wants to thank you for not compromising quality. We are determined to offer excellence in customer service as well as provide you with the very best value for your dollar.

Sincerely,

All Employees of

MEYER MANUFACTURING CORPORATION

When the PTO is referred to, it means power take-off from the tractor.

The formula mixer may be referred to as mixer, implement, equipment or machine in this manual.



IMPORTANT: You are urged to study this manual and follow the instructions carefully. Your efforts will be repaid in better operation and service as well as a savings in time and repair expense. Failure to read this manual and understand the machine could lead to serious injury. If you do not understand instructions in this manual, contact either your dealer or Meyer Manufacturing Corp. at Dorchester, WI 54425.



WARRANTY: At the front of this manual is an "Owner's Registration Form". Be sure your dealer has completed this form and promptly forwarded a copy to Meyer Manufacturing to validate the manufacturer's warranty. The product model and serial number are recorded on this form and on the inside of the front cover for proper identification of your Meyer implement by your dealer and the manufacturer when ordering repair parts. The mixer serial number plate is located on the front left hand side of the mixing tub. The trailer serial number plate is located on the left hand side of the hitch.



REPAIR PARTS: At the back of this manual is the repair parts section. All replacement parts are to be obtained from or ordered through your Meyer dealership. When ordering repair parts, refer to the parts section and give complete information including quantity, correct part number, detailed description and even model number and serial number of the implements which needs repair parts.

Manufacturer's Statement: Meyer Manufacturing Corporation reserves the right to make improvements in design, or changes in specifications at any time, without incurring any obligation to owners of units previously sold. This supersedes all previous published instructions.



4.0 MANUFACTURER'S WARRANTY

04/2014

MEYER FORMULA MIXER

- I The "Owner's Registration Form" must be completed in full and promptly returned to Meyer Mfg. Corp. for this warranty to become both valid and effective. All warranties on New Meyer Mixers shall apply only to the original retail customer from an authorized Meyer Mfg. Corp. dealership.
- II This warranty shall not apply to any Meyer Mixer which has been subjected to misuse, negligence, alteration, accident, incorrect operating procedures, has been used for an application not designed for or pre-authorized by Meyer in writing, has had the serial numbers altered, or which shall have been repaired with parts other than those obtained through Meyer Mfg. Corp. Meyer is not responsible for the following: Depreciation or damage caused by normal wear, lack of reasonable and proper maintenance, failure to follow the operator's manual recommendations or normal maintenance parts and service. Meyer is not responsible for rental of replacement equipment during warranty repairs, damage to a power unit (including but not limited to a truck or tractor), loss of earnings due to equipment down time, or damage to equipment while in transit to or from the factory or dealer.
- III Meyer Mfg. Corp. warrants New Meyer Mixer to be free from defects in material and workmanship under recommended use and maintenance service, as stated in the operator's and parts manuals, as follows:
 - A. Meyer Mfg. Corp. will repair or replace F.O.B. Dorchester, WI, as Meyer Mfg. Corp. elects, any part of a new Meyer Mixer which is defective in material or workmanship:
 - i Without charge for either parts or labor during the first (1) year from purchase date to the original retail customer.
 - B. In addition to the above basic warranty, Meyer Mfg. Corp. will repair or replace F.O.B. Dorchester, WI as Meyer Mfg. Corp. elects:
 - i Any part of the following which is defective in material or workmanship (not neglect to recommended use and service) with a "pro-rated" charge for parts only (not labor) during the stated time period from date of purchase to the original retail customer. 1st year 100%, 2nd year 100%, 3rd year 50%, 4th year 25%, 5th year 10%
 - a. The Formula Mixer Planetary Gearbox. Meyer Part #'s 119-1680-13.5-1, 119-1680-24.18-1, 119-18-13.92-1, 119-21-25.57-1, 119-32-24.8-1.
- IV COMMERCIAL USE: Coverage as in paragraph III.A.i. only, except warranty coverage is for (90) days for parts and labor to the original commercial retail customer.
- V Repairs eligible for labor warranty must be made by Meyer Mfg. Corp. or an authorized Meyer dealership. The original retail customer is responsible for any service call and/or transportation of the mixer to the dealership or the factory for warranty service.
- VI Except as stated above, Meyer Mfg. Corp. shall not be liable for injuries or damages of any kind or nature, direct, consequential, or contingent, to persons or property. This warranty does not extend to loss of crop or for any other reasons.
- VII No person is authorized to give any other warranties or to assume any other obligation on Meyer Mfg. Corp.'s behalf unless made or assumed in writing by Meyer Mfg. Corp. This warranty is the sole and exclusive warranty which is applicable in connection with the manufacture and sale of this product and Meyer Mfg. Corp.'s responsibility is limited accordingly.

Purchased Product Warranty:

This warranty does not apply to component parts not manufactured by Meyer such as but not limited to wheels, tires, PTO shafts, clutches, hydraulic cylinders, scales, etc.



TABLE OF CONTENTS

1.0	IMPORTANT INFORMATION	2
2.0	PRE-DELIVERY & DELIVERY CHECK LIST	3
3.0	INTRODUCTION	5
4.0	MANUFACTURER'S WARRANTY	7
5.0	SAFETY	15
5.1	SAFETY PRECAUTIONS	16
5.2	SAFETY SIGNS	18
5.3	SHUTOFF & LOCKOUT POWER	24
5.3.1	SHUTOFF & LOCKOUT POWER RECOMMENDATIONS	24
6.0	PRE-OPERATION	25
6.1	STATIC INSPECTION	25
6.2	LIGHT HOOK-UP	26
6.3	HYDRAULIC HOOK-UP	26
6.4	PTO DRIVELINE OPTION	27
6.5	TRACTOR DRAWBAR SETUP	28
6.6	HITCHING TO TRACTOR	29
6.6.1	JACK STORAGE	29
6.7	START-UP AND SHUT-DOWN	30
6.7.1	START-UP	30
6.7.2	SHUT-DOWN	30
6.8	OPERATIONAL CHECKS	31
6.8.1	CONTROLS	32
6.8.1.1	STOP & SHIFT GEARBOX	32
6.8.1.2	POWER SHIFT TRANSMISSION	32
6.9	TRANSPORTING	33
6.9.1	SAFETY CHAIN	34
6.9.2	TRACTOR TOWING SIZE REQUIREMENTS	35
6.9.3	BRAKE INFORMATION (OPTIONAL)	35
6.9.3.1	PEDAL OPERATED HYDRAULIC BRAKES	35
6.10	OPTIONAL EQUIPMENT	35

TABLE OF CONTENTS

7.0	OPERATION	37
7.1	GENERAL	37
7.1.1	MATERIAL.....	38
7.1.2	CUTOUT CLUTCH	38
7.2	LOADING	39
7.2.1	LOADING SEQUENCE	40
7.3	MIXING.....	40
7.4	PLATFORM OPERATION.....	41
7.5	FOLDING LADDER	41
7.6	UNLOADING	42
7.7	UNHOOKING THE TRACTOR.....	43
7.8	HAY STOP ADJUSTMENT	44
7.8.1	HAY STOP LOCK BOLT	44
7.9	MIXER TROUBLESHOOTING GUIDE.....	45
8.0	MAINTENANCE	47
8.1	GENERAL	47
8.2	LUBRICATION	47
8.2.1	DAILY LUBRICATION	48
8.2.2	EVERY 8 HOURS.....	50
8.2.3	MONTHLY LUBRICATION	51
8.2.4	EVERY 40 HOURS.....	52
8.2.5	FIRST 50 HOURS	52
8.2.6	EVERY 250 HOURS.....	52
8.2.7	SEMIANNUALLY OR EVERY 500 - 600 HOURS (WHICHEVER IS FIRST)	53
8.2.8	ANNUALLY	53
8.2.9	ANNUALLY OR EVERY 1000 HOURS (WHICHEVER IS FIRST)	54
8.2.10	ANNUALLY OR EVERY 2000 HOURS (WHICHEVER IS FIRST)	54
8.2.11	EVERY TWO YEARS OR WHEN DISCOLORED.....	54
8.2.12	EVERY 5000 HOURS.....	54
8.2.13	GREASE HUBS.....	55
8.2.14	GEARBOX/TRANSMISSION OIL & FILTER CHANGE PROCEDURES	55
8.2.14.1	PLANETARY GEARBOX	56
8.2.14.2	STOP & SHIFT GEARBOX (IF EQUIPPED).....	57
8.2.14.3	POWER SHIFT TRANSMISSION (IF EQUIPPED).....	58

TABLE OF CONTENTS

8.3	ADJUSTMENTS.....	59
8.3.1	SIDE DISCHARGE CONVEYOR	60
8.3.2	BELT CONVEYOR TENSION	60
8.3.3	TRACKING	61
8.3.4	FRONT DISCHARGE CONVEYOR - CHAIN.....	63
8.3.5	AUGER SCRAPER PLATE	63
8.3.6	AUGER TIMING	63
8.3.7	STOP & SHIFT DRIVELINE ALIGNMENT	64
8.3.8	PTO CUTOUT CLUTCH CONNECTION	65
8.3.9	KNIVES	65
8.3.9.1	KNIFE REMOVAL	65
8.3.9.2	ADDING KNIVES	65
8.3.9.3	KNIFE PLACEMENT.....	65
8.3.9.4	KNIFE POSITION	66
8.3.9.5	REPLACING DAMAGED OR WORN KNIVES	66
8.3.10	BRAKE ADJUSTMENT (IF EQUIPPED)	66
8.3.11	WHEEL BEARING PRELOAD	66
8.4	FASTENER TORQUE SPECIFICATIONS.....	67
8.4.1	GENERAL TORQUE SPECIFICATIONS	67
8.4.2	WHEEL TORQUE	69
8.4.3	HUB TORQUE.....	69
8.5	ELECTRICAL	70
8.5.1	POWER SHIFT REMOTE CONTROL PROGRAMMING.....	70
8.5.1.1	REMOTE TROUBLESHOOTING.....	71
8.5.2	DIGITAL SCALE INDICATOR	71
8.6	BRAKES (OPTIONAL)	72
8.6.1	BRAKE BLEEDING	72
8.7	WHEELS AND TIRES	73
8.7.1	WHEEL INSTALLATION	73
8.7.2	TIRE INFLATION.....	73
8.7.3	IMPLEMENT TIRES	74
8.8	STORING THE IMPLEMENT	75
8.9	RETURN THE IMPLEMENT TO SERVICE	75

TABLE OF CONTENTS

9.0 REPAIR PARTS	77
STOP & SHIFT LIGHTS	79
POWER SHIFT LIGHTS	80
POWER SHIFT LIGHTS	80
WEIGH BAR WIRING DIAGRAM	82
STOP & SHIFT ELECTRICAL SYSTEM	84
STOP & SHIFT WIRING SCHEMATIC	84
POWER SHIFT ELECTRICAL SYSTEM	86
POWER SHIFT ELECTRICAL SYSTEM	86
POWER SHIFT JUNCTION BOX	88
POWER SHIFT JUNCTION BOX	89
SINGLE AXLE TRAILER	90
SINGLE AXLE TRAILER (CONT'D)	92
TANDEM AXLE TRAILER	94
TANDEM AXLE TRAILER (CONT'D)	96
TANDEM AXLE TRAILER (CONT'D)	98
STOP & SHIFT PTO SHROUD	100
POWER SHIFT PTO SHROUD	100
75-0219 HUB ASSEMBLY	102
75-0217 OIL BATH HUB ASSEMBLY	103
75-0218 OIL BATH HUB ASSEMBLY	104
MIXER	106
FRONT FLAT & INCLINE BASE BELT CONVEYOR	108
FRONT FLAT & INCLINE BASE BELT CONVEYOR (CONT'D)	110
FRONT FLAT & INCLINE BASE BELT CONVEYOR (CONT'D)	112
FRONT FLAT & INCLINE BASE BELT CONVEYOR (CONT'D)	114
FRONT FLAT BELT CONVEYOR HYDRAULIC SCHEMATIC	116
FRONT INCLINE BELT CONVEYOR	118
FRONT INCLINE BELT CONVEYOR (CONT'D)	120
FRONT INCLINE BELT CONVEYOR (CONT'D)	122
FRONT INCLINE BELT CONVEYOR (CONT'D)	124
FRONT LH INCLINE BELT CONVEYOR HYDRAULIC SCHEMATIC	126
FRONT RH INCLINE BELT CONVEYOR HYDRAULIC SCHEMATIC	126
FRONT INCLINE BELT CONVEYOR STOP	128
FRONT FLAT & INCLINE CHAIN CONVEYOR ASSEMBLY	130
FRONT FLAT & INCLINE CHAIN CONVEYOR ASSEMBLY (CONT'D)	132
FRONT FLAT CONVEYOR	134

TABLE OF CONTENTS

FRONT INCLINE CONVEYOR.....	134
FLAT CHAIN CONVEYOR HYDRAULIC SCHEMATIC	136
FRONT DISCHARGE INCLINE CHAIN CONVEYOR HYDRAULIC SCHEMATIC	138
FRONT DISCHARGE INCLINE CHAIN CONVEYOR HYDRAULIC SCHEMATIC	140
SIDE DISCHARGE BELT CONVEYOR	142
SIDE DISCHARGE BELT CONVEYOR (CONT'D)	144
SIDE DISCHARGE BELT CONVEYOR (CONT'D)	146
SIDE DISCHARGE CHAIN CONVEYOR	148
SIDE DISCHARGE CHAIN CONVEYOR (CONT'D)	150
SIDE DISCHARGE INCLINE BELT & CHAIN CONVEYOR HYDRAULIC SCHEMATIC.....	152
DOOR.....	154
OPTIONAL REAR DOOR HYDRAULIC SCHEMATIC FOR FRONT DOOR & SIDE DOOR MOD- ELS	156
DOOR HYDRAULIC SCHEMATIC FRONT / LEFT / RIGHT / DUAL LEFT & RIGHT DOOR.	157
LADDER	158
VIEWING PLATFORM.....	160
AUGER	162
AUGER (CONT'D).....	164
STOP & SHIFT DRIVELINE	166
STOP & SHIFT DRIVELINE (CONT'D)	168
POWER SHIFT DRIVELINE.....	170
815 / 1015 / 1015P STOP & SHIFT GEARBOX.....	172
815 / 1015 / 1015P STOP & SHIFT GEARBOX (CONT'D)	174
815P / 815C / 1015P / 1015C / 1215 STOP & SHIFT GEARBOX	176
815P / 815C / 1015P / 1015C / 1215 STOP & SHIFT GEARBOX (CONT'D)	178
815P / 815C / 1015P / 1015C / 1215 STOP & SHIFT GEARBOX (CONT'D)	180
815 / 1015 / 1215 POWER SHIFT TRANSMISSION (EXTERNALS).....	182
POWER SHIFT TRANSMISSION (INTERNALS).....	184
2100 SERIES PLANETARY	186
3200 SERIES PLANETARY	188
STOP & SHIFT PLANETARY GEARBOX OIL SYSTEM	190
POWER SHIFT PLANETARY GEARBOX OIL SYSTEM	192
STOP & SHIFT GEARBOX OIL SYSTEM.....	194
STOP & SHIFT GEARBOX OIL SYSTEM.....	194
POWER SHIFT TRANSMISSION OIL COOLING SYSTEM	196
LARGE MIXER 1-3/8-21 SPLINE X 1-3/4-20 SPLINE PTO DRIVE SHAFT	198
LARGE MIXER 1-3/8-21 SPLINE X 1-3/4-20 SPLINE PTO DRIVE SHAFT (OPTIONAL).....	200

TABLE OF CONTENTS

POWER SHIFT 1-3/4-20 SPLINE X 1-3/4-20 SPLINE PTO DRIVE SHAFT	202
POWER SHIFT 1-3/4-20 SPLINE X 1-3/4-20 SPLINE PTO DRIVE SHAFT	204
1-3/4-20 SPLINE X 1-3/4-20 SPLINE 2500 SERIES DRIVELINE	206
DOUBLE UNIVERSAL JOINT W/CUTOUT CLUTCH	207
YOKE CUTOUT CLUTCH	208
CUTOUT CLUTCH	209
1-3/4-20 SPLINE X 1-3/4-20 SPLINE DRIVESHAFT	210
10.0 OPTIONAL PARTS	211
HAY RETAINING RING	212
8" CAPACITY EXTENSION	213
TIP OFF FRONT INCLINE DISCHARGE (CHAIN ONLY) & SIDE DISCHARGE.....	214
SIDE DISCHARGE SLIDE TRAY	215
SLIDE TRAY HYDRAULIC SCHEMATIC	216
DRUM BRAKE ASSEMBLY	217
HAND/FOOT BRAKE CONTROL ACTUATOR ASSEMBLY	218
SINGLE AXLE HYDRAULIC BRAKE SCHEMATIC	220
TANDEM HYDRAULIC BRAKE SCHEMATIC	221
REMOTE SCALE MOUNT	222
RUBBER SIDE DOOR CHUTE ASSEMBLY	224
CONVEYOR HANGING MAGNET & WEIGHT ASSEMBLY	226
CONVEYOR DEFLECTOR ASSEMBLY	226
POWER MAGNET	228
11.0 SPECIFICATIONS.....	231
NOTES	234
12.0 MAINTENANCE RECORDS	235

5.0 SAFETY

The Meyer implement is manufactured with operator safety in mind. Located on the implement are various safety signs to aid in operation and warn of danger or caution areas. Pay close attention to all safety signs on the implement.

Carefully follow the operating and maintenance instructions in this manual and all applicable safety laws. Failure to follow all safety procedures may result in serious injury or death.

Before attempting to operate this implement, read and study the following safety information. In addition, make sure that every individual who operates or works with the implement, whether family member or employee, is familiar with these safety precautions.

Meyer Mfg. Corp. provides guards for exposed moving parts for the operator's protection; however, some areas cannot be guarded or shielded in order to assure proper operation. The operator's manual and safety signs on the implement itself warn you of dangers and must be read and observed closely!



Safety Alert Symbol

This symbol is used to call attention to instructions concerning personal safety. Be sure to observe and follow these instructions. Take time to be careful!



DANGER

The signal word **DANGER** on the machine and in the manual identifies a hazardous situation which, if not avoided, WILL result in death or serious injury.



WARNING

The signal word **WARNING** on the machine and in the manual indicates a potentially hazardous situation which, if not avoided, COULD result in serious injury or death.



CAUTION

The signal word **CAUTION** on the machine and in the manual indicates a potentially hazardous situation which, if not avoided, MAY result in minor or moderate injury. It may also be used to alert against unsafe practices.

IMPORTANT

This notice identifies procedures which must be followed to avoid damage to the machine.

Danger, Warning, Caution, and instructional decals and plates are placed on the equipment to protect anyone working on or around this machine, as well as the components of the machine. All personnel operating or maintaining this equipment must familiarize themselves with all Danger, Warning, Caution, and instructional decals and plates.

5.1 SAFETY PRECAUTIONS

 **CAUTION**



All individuals who will operate this implement must read and completely understand this Owner / Operator's and Parts Manual. Operator must receive instructions before operating the machine. Untrained operators can cause injury or death.

- DO NOT allow anyone to operate, service, inspect or otherwise handle this equipment until all operators have read and understood all of the instructional materials in this Operator's And Parts Manual and have been properly trained in its intended usage.
- For an operator to be qualified, he or she must not use drugs or alcohol which impair alertness or coordination while working. An operator who is taking prescription drugs must get medical advice to determine if he or she can safely operate a machine and the equipment.
- Make sure all personnel can READ and UNDERSTAND all safety signs.
- DO NOT allow minors (children) or inexperienced persons to operate this equipment.
- DO NOT operate until all shields and guards are in place and securely fastened.
- DO NOT step up on any part of the equipment that is not designated as a ladder or viewing platform at any time.
- DO NOT adjust, clean or lubricate while the equipment is in motion.
- Inspect when first delivered and regularly thereafter; that all connections and bolts are tight and secure before operating.
- Know how to stop operation of the equipment before starting it!
- Make certain everyone is clear of the equipment before applying power.
- Keep hands, feet and clothing away from moving parts. Loose or floppy clothing should not be worn by the operator.
- Observe all applicable traffic laws when transporting on public roadways (where legal to do so). Check local laws for all highway lighting and marking requirements.
- Shut off and lock out power before adjusting, servicing, maintaining or clearing an obstruction from this machine. Refer to 5.3 SHUTOFF & LOCKOUT POWER.
- Always enter curves or drive up or down hills at a low speed and at a gradual steering angle.
- Never allow riders on either tractor / truck or equipment.
- Keep tractor / truck in a lower gear at all times when traveling down steep grades.
- Stay away from overhead power lines. Electrocution can occur without direct contact.
- Use only properly rated undercarriage and tires.

Safety Precautions For Tractor Towed Units:

- Do not exceed 20 mph (32 kph). Reduce speed on rough roads and surfaces.
- Always install a SMV emblem on pull-type equipment when transporting on roadways and keep clean and bright.
- Always yield to oncoming traffic in all situations and move to the side of the road so any following traffic may pass.
- Comply with state and local laws governing highway safety and movement of machinery on roadways.

Safety Precautions For Hydraulic System:

- Check hydraulic tubes, hoses and fittings for damage and leakage. Never use hands to check for leaks. Hydraulic tubes and hoses must be properly routed and have adequate support and secure clamps. Tighten or replace any parts that show leakage.
- Always clean fluid spills. Do not use gasoline or diesel fuel for cleaning parts. Use commercial nonflammable solvents.

5.2 SAFETY SIGNS

CAUTION

Read all safety signs on the implement and in this manual. Keep all safety signs clean and replace any damaged or missing safety signs before operating the equipment. Do not remove any safety signs. Safety signs are for operator protection and information.

FRONT OF IMPLEMENT

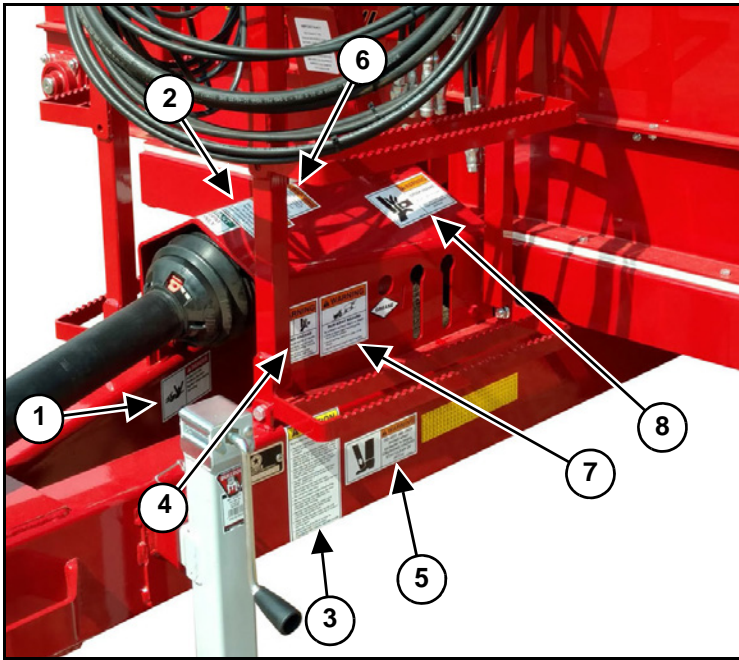

PART NO. 46-3600-2
(Located On Trailer Frame Underneath Housing)



PART NO. 46-3600-9

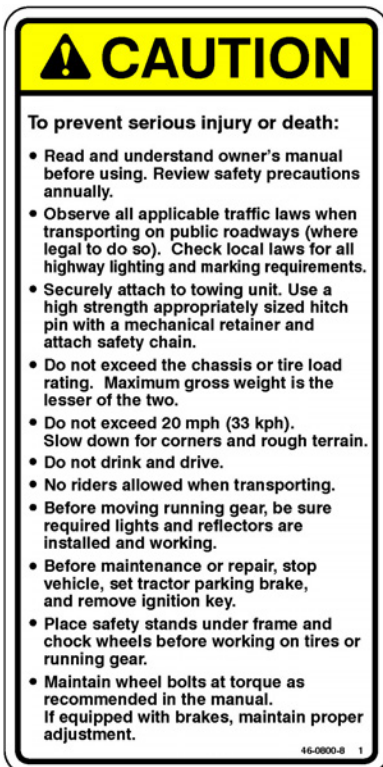

PART NO. 46-0800-8



PART NO. 46-0800-6



PART NO. 46-0800-7



PART NO. 46-3600-6



PART NO. 46-0004-2

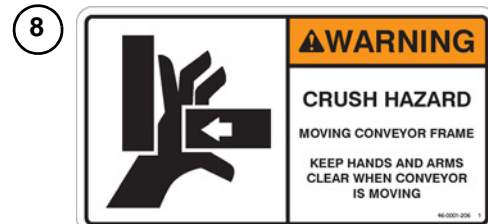

PART NO. 46-0001-2

FRONT OF IMPLEMENT

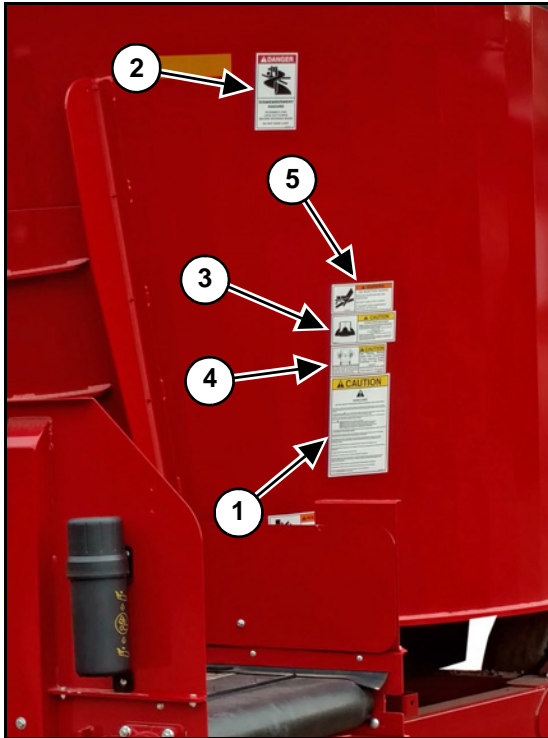

1

⚠ CAUTION



SAFETY FIRST

Do Not Operate This Machine Without Reading These Instructions!

Meyer Manufacturing Corporation provides guards for exposed moving parts for the operator's protection; however, some areas cannot be guarded or shielded in order to ensure proper operation. The operator's manual and safety signs on the equipment itself warn you of hazards and must be read and observed closely!

The safety alert symbol  is used to call attention to instructions concerning personal safety. Be sure to observe and follow these instructions. Take time to be careful!

⚠ SAFETY PRECAUTIONS

DO NOT allow anyone to operate, service, inspect or otherwise handle this equipment until all operators have read and understood all of the instructional materials in the operator's and parts manual and have been properly trained in its intended usage.

DO NOT operate until all shields and guards are in place and securely fastened.

DO NOT step up on any part of the equipment that is not designated as a seat, ladder, or viewing platform at any time. Never allow riders on either tractor / truck or equipment.

Ensure the machine is and will remain in the OFF condition before adjusting, servicing, maintaining, or clearing an obstruction from this machine.

PTO OPTIONS: The tractor PTO **MUST** match the implement PTO. **NEVER USE PTO ADAPTERS.** PTO shield **MUST** be in place and rotate freely. Always run PTO in a straight line to avoid an accident due to PTO damage.

Know how to stop operation of the equipment before starting it! Make certain everyone is clear of the equipment before applying power. Make certain everyone stays clear of the discharge opening while operating.

Keep hands, feet, and clothing away from moving parts. Loose or floppy clothing should not be worn by the operator.

Observe all applicable traffic laws when transporting on public roadways (where legal to do so). Check local laws for all highway lighting and marking requirements.

Keep all safety signs clean and replace any damaged or missing safety signs before operating the equipment. **DO NOT** remove any safety signs. If any safety signs become damaged or lost, call your local Meyer dealer or Meyer factory direct 1-800-325-9103 for replacement. Always use **GENUINE MEYER** replacement parts.

46-0001-22 1

PART NO. 46-0001-22

2

⚠ DANGER



DISMEMBERMENT HAZARD

DISCONNECT AND LOCK OUT POWER BEFORE ENTERING MIXER

DO NOT HAND LOAD

46-0001-213 1

PART NO. 46-0001-213

3

⚠ CAUTION

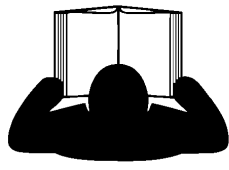

TO PREVENT SERIOUS INJURY OR DEATH

- DO NOT start, operate, or work on this machine without first carefully reading and thoroughly understanding the entire contents of the operators manual. (Require the same of all personnel who will operate this machine.)
- If operators manual is lost, contact your nearest Meyer Dealership or write or call:

MEYER MFG., CORP.
P.O. BOX 405 • Dorchester, WI 54425-0405
Phone 1-800-325-9103

 Please give your name, address, phone number, model and serial number of your machine. A manual will be furnished.
- If you have any questions about operation or adjustments, and maintenance of this machine, contact your Meyer Dealership or Meyer Mfg., Corp. before starting or continuing the operation of this machine.

46-0001-35 1

PART NO. 46-0001-35

4

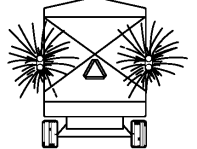

⚠ CAUTION

Use Flashing Warning Lights when transporting on **ALL** highways (public roadways) at **ALL** times.

EXCEPT WHEN PROHIBITED BY LAW!

(Check w/local law enforcement)

46-0001-62 1

By all State and Federal laws, implement lights do not replace the SMV (Slow-Moving Vehicle) Identification Emblem. All towed agricultural vehicles must display SMV Emblems when traveling LESS than 20 mph (32 kph).

PART NO. 46-0001-62

5



⚠ WARNING

OIL INJECTION HAZARD

RELIEVE PRESSURE BEFORE SERVICING.

DO NOT CHECK WITH HANDS.

IF INJURED SEEK EMERGENCY MEDICAL ATTENTION.

46-8500-7 1

PART NO. 46-8500-7

FRONT OF IMPLEMENT

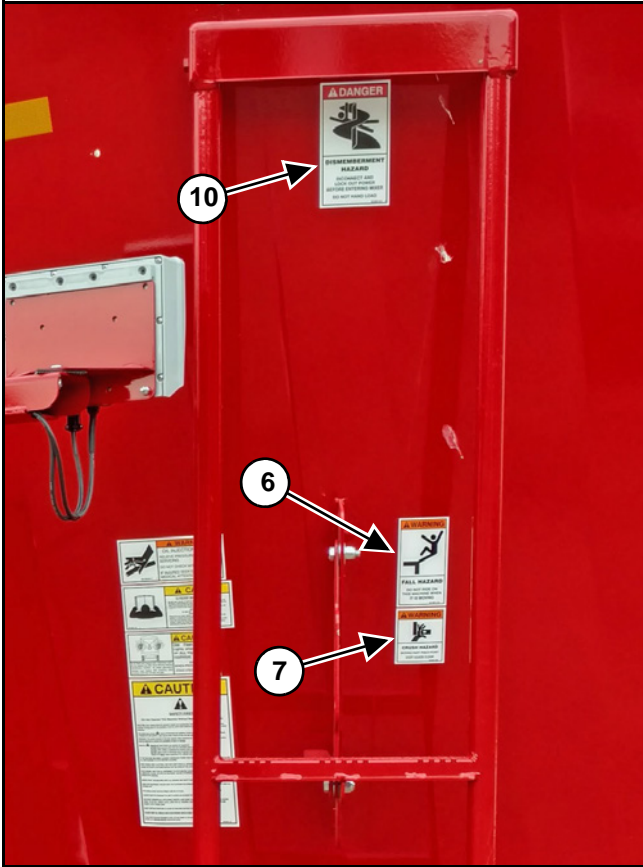

PART NO. 46-0001-210



PART NO. 46-0001-205



PART NO. 46-0001-213

LEFT SIDE OF IMPLEMENT



PART NO. 46-0001-211
(Located Under Mixing Tub)



PART NO. 46-0001-212
(Behind Belting - Not Shown)



PART NO. 46-0001-206
(Both Sides On Some Models)



PART NO. 46-8500-7

RIGHT SIDE OF IMPLEMENT

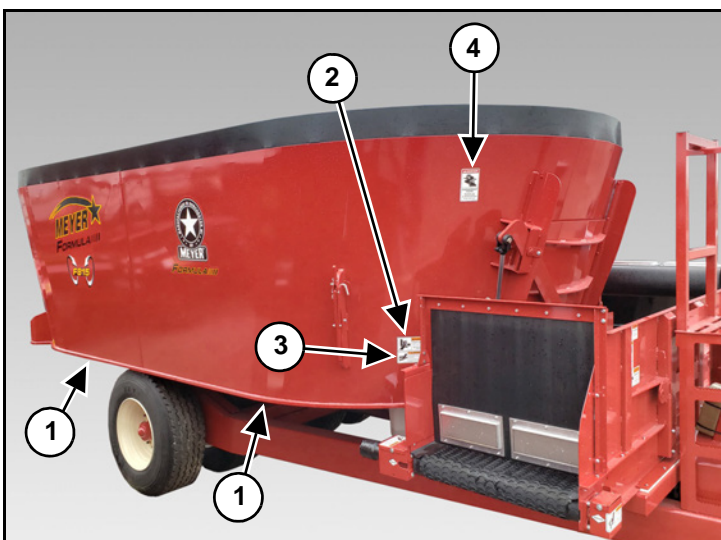

PART NO. 46-0001-213

LEFT SIDE OF IMPLEMENT

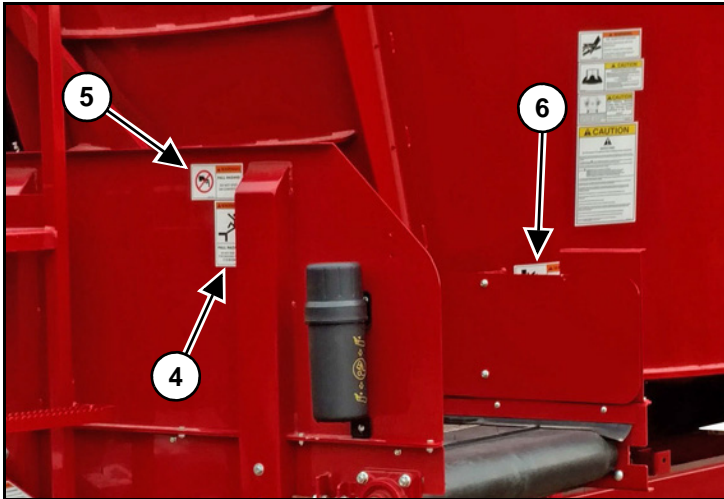

PART NO. 46-0001-4
(Located On Top Of Shield - Not Shown)

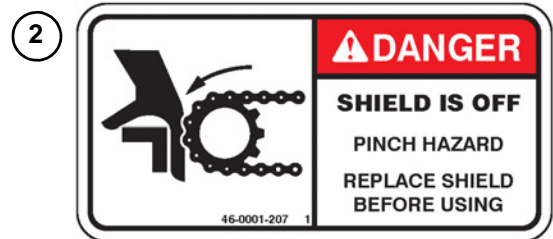

PART NO. 46-0001-207
(Located Under Shield - Not Shown)

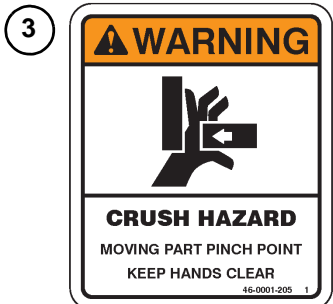

PART NO. 46-0001-205



PART NO. 46-0001-210



PART NO. 46-0001-209

RIGHT SIDE OF IMPLEMENT

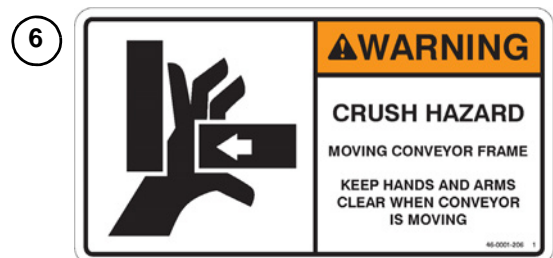
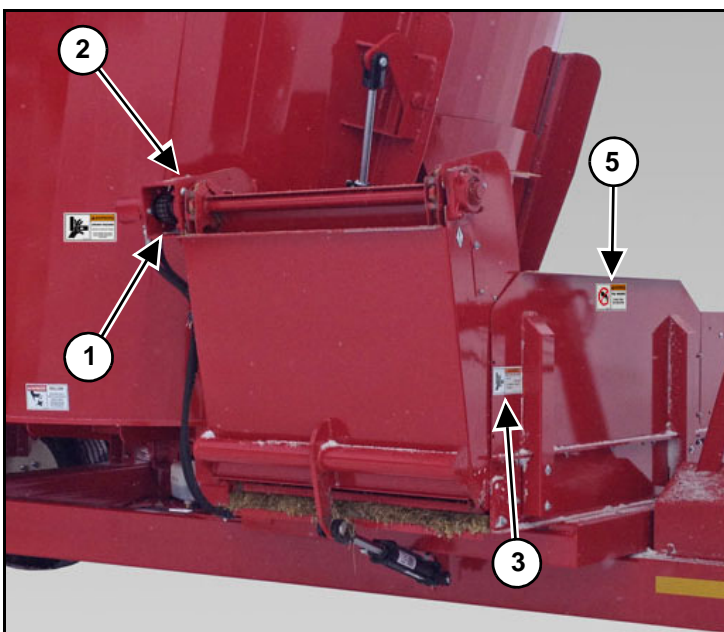

PART NO. 46-0001-206
(Both Sides On Some Models)

BACK OF IMPLEMENT

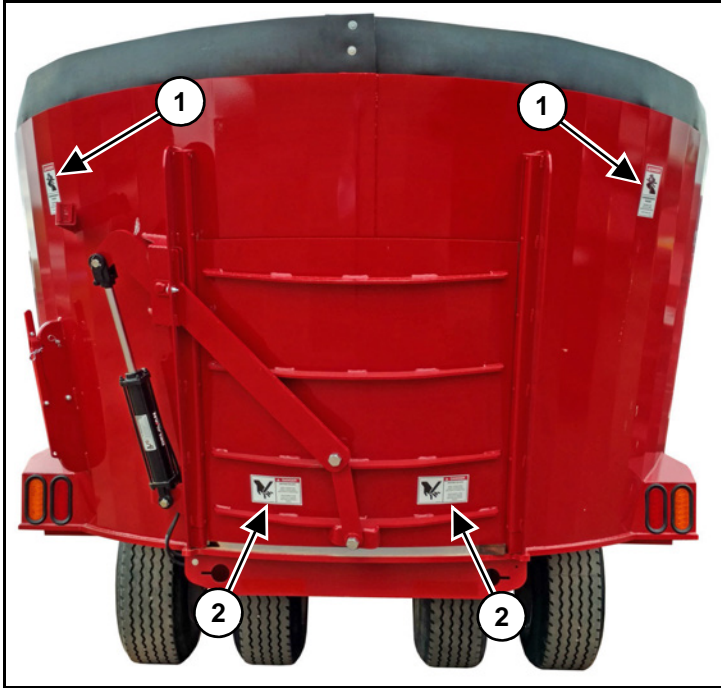

PART NO. 46-0001-213

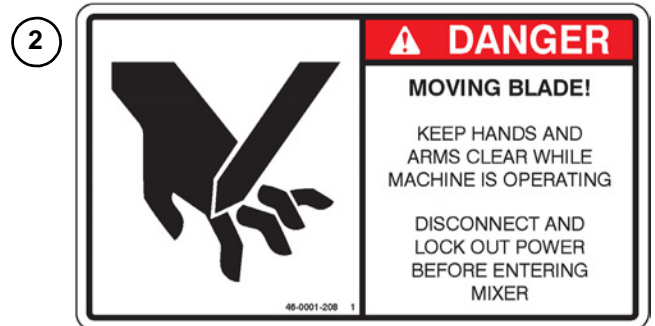

PART NO. 46-0001-208

SIDE DOOR CONVEYOR (OPTION)

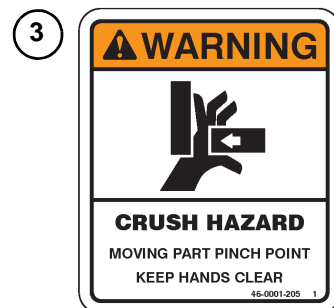
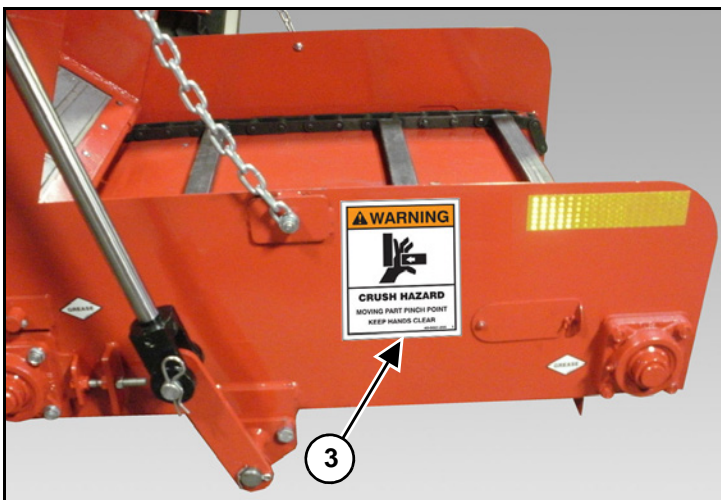

PART NO. 46-0001-205

5.3 SHUTOFF & LOCKOUT POWER



CAUTION

Any individual that will be adjusting, servicing, maintaining, or clearing an obstruction from this machine needs to ensure that this machine stays safely OFF until the adjustment, service, or maintenance has been completed, or when the obstruction has been cleared, and that all guards, shields, and covers have been restored to their original position. The safety of all individuals working on or around this machine, including family members, are affected. The following procedure will be referred to throughout this manual, so be familiar with the following steps.

5.3.1 Shutoff & Lockout Power Recommendations

1. Think, Plan and Check

- a. **THINK** through the entire procedure and identify all the steps that are required.
- b. **PLAN** what personnel will be involved, what needs to be shut down, what guards/shields need to be removed, and how the equipment will be restarted.
- c. **CHECK** the machine over to verify all power sources and stored energy have been identified including engines, hydraulic and pneumatic systems, springs and accumulators, and suspended loads.

2. **Communicate** - Let everyone involved, including those working on or around this machine, that work is being done which involves keeping this machine safely “OFF”.

3. **Power Sources**

- a. **LOCKOUT** - Shut off engines and take the key, or physically lock the start/on switch or control. Disconnect any power sources which are meant to be disconnected (i.e. electrical, hydraulic, and PTO of pull-type units).
- b. **TAGOUT** - Place a tag on the machine noting the reason for the power source being tagged out and what work is being done. This is particularly important if the power source is not within your sight and/or will need to be isolated for a longer period of time.

4. **Stored Energy** - Neutralize all stored energy from its power source. Ensure that this machine is level, set the parking brake, and chock the wheels. Disconnect electricity, block movable parts, release or block spring energy, release pressure from hydraulic and pneumatic lines, and lower suspended parts to a resting position.

5. **Test** - Do a complete test and personally double check all of the above steps to verify that all of the power sources are actually disconnected and locked out.

6. **Restore Power** - When the work has been completed, follow the same basic procedures, ensuring that all individuals working on or around this machine are safely clear of the machine before locks and tags are removed and power is restored.

IMPORTANT

It is important that everyone who works on this equipment is properly trained to help ensure that they are familiar with this procedure and that they follow the steps outlined above.

This manual will remind you when to SHUTOFF & LOCKOUT POWER.

6.0 PRE-OPERATION



Always keep all shields and guards in place and securely fastened. Keep hands, feet and clothing away from moving components.



DO NOT allow anyone to operate, service, inspect or otherwise handle this implement until all operators have read and understand all of the instructional materials in this Owner / Operator's and Parts Manual and have been properly trained in its intended usage.

Verify that the implement is securely hitched to the tractor/truck.

Verify that all electrical/hydraulic connections and bolts/hardware are tight and securely fastened before operating the implement.

Wear safety glasses to prevent eye injury when any of the following conditions exist:

- When fluids are under pressure.
- Flying debris or loose material is present.
- Tools are being used.

6.1 STATIC INSPECTION



Hydraulic fluid escaping under pressure can have sufficient force to cause injury. Keep all hoses and connections in good serviceable condition.

Before operating the mixer for the first time and each time thereafter, check the following items:

1. Check that all safety signs are in good and legible condition.
2. Inspect the mixer for proper adjustments. Refer to Section 8.3 ADJUSTMENTS.
3. Check that all lubrication has been completed. Refer to Section 8.2 LUBRICATION.
4. Make sure that all guards and shields are in place, secured and functioning as designed.
5. Check condition of all hydraulic components for leaks and electrical cords and cables for wear. Repair or replace as required.
6. Check the planetary gearbox and stop & shift gearbox reservoir (If Equipped) for proper oil level. Check power shift transmission sight glass (If Equipped) for proper oil level. Refer to Section 8.2 LUBRICATION.
7. Check for and remove any foreign objects in the mixing chamber and discharge opening.
8. Be sure that there are no tools laying on or in the mixer.
9. Verify that all electrical and hydraulic connections are tight and secure before operating.
10. Check that all hardware is in place and is tight.
11. Watch for any worn or cracked welds. If found, have qualified personnel repair immediately or replacement is necessary.
12. Check all bearings. Replace as needed.
13. Inspect any wear items. i.e.: Knives, scrapers, kicker wear plate. Replace as required.
14. Inspect the tires for excessive wear or damage and inflate to the recommended pressure. Refer to Section 8.7 WHEELS AND TIRES.
15. Inspect the condition of axles, o-beams, spindles, and safety lighting. Repair or replace as required.
16. Check that the brakes are clean and clean them if necessary.(Brake Option Only) Refer to Section 8.6 BRAKES (OPTIONAL).

6.2 LIGHT HOOK-UP

NOTE: The lighting system provided is intended for being transported by an agricultural tractor.

Ensure that lights and indicators are clean and in good working order. When attaching to a towing vehicle other than a tractor always check lighting for proper operation as wiring may vary. Connect to the standardized 7-pin socket located at the back of the tractor.

Models	Color	Function	SAE Terminal	SAE Connector
All	White	Ground	1	
Power Shift Model Only (Prior to SN 22VM1215203)	Blue	Temperature Control Box Ground	1	
Power Shift Model Only (SN 22VM1215203 & Later)	White	J-Box Ground	1	
All		Not Used	2	
All	Yellow	Left Turn & Hazard	3	
All		Not Used	4	
All	Green	Right Turn & Hazard	5	
All	Brown	Tail Lights	6	
Stop & Shift		Auxiliary Power	7	
Power Shift Model Only (Prior to SN 22VM1215203)	Red	Temperature Control Box	7	
Power Shift Model Only (SN 22VM1215203 & Later)	Black	J-Box	7	

NOTE: The brake wire should only be connected to the #4 terminal if the #4 terminal on the tractor is confirmed to be a brake light terminal. If the tractor does not have a brake light terminal, cap / seal off the end of the brake wire of the implement (secure to other wires).

6.3 HYDRAULIC HOOK-UP



Hydraulic fluid escaping under pressure can have sufficient force to cause injury. Keep all hoses and connections in good serviceable condition.

Whenever working on any part of the hydraulics, safely relieve hydraulic pressure before starting.

IMPORTANT

Do not exceed maximum PSI or a motor failure could result.

Pull Type: Requires 25 GPM @ 3000 PSI.

Call the factory if additional information is needed.

Note: The PTO horsepower and/or hydraulic requirements may not reflect adequate tractor size for towing the machine.

6.4 PTO DRIVELINE OPTION



Do not operate without PTO guard on implement and tractor. Maintain PTO drive shaft guard in good operating condition. Replace them if damaged and not turning freely.



Shutoff and lockout power before adjusting, servicing, maintaining, or clearing an obstruction from this machine. Refer to section 5.3 SHUTOFF & LOCKOUT POWER.

The tractor half of the PTO drive shaft assembly must be locked securely to the tractor output shaft and the implement half of the PTO drive shaft assembly must be locked securely to the implement driveline.

See the PTO Installation, Service, and Safety Instruction Manual for additional PTO details. For a replacement manual, call the factory at 1-800-325-9103.

See the ADMA Safety Manual for further safety situations and precautions, ensure all operators become familiar with it. For a replacement manual, call the factory at 1-800-325-9103.

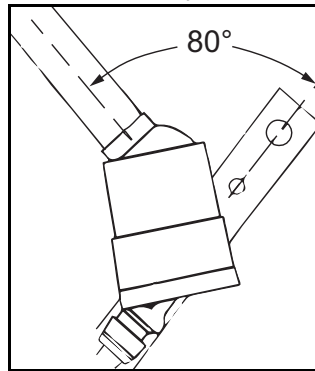

IMPORTANT

Do not exceed the maximum 80° turning angle on the constant velocity PTO driveline. Exceeding the turning angle will damage the constant velocity “center housing” and exerts excessive pressures on the PTO input center shaft and related bearings.

6.5 TRACTOR DRAWBAR SETUP

Do not operate 1000 RPM implements at 540 RPM. No PTO adapter should be used to alter speed or geometry.

Set the tractor drawbar to conform to the standard dimensions as shown. An improperly located hitch point may cause damage to the universal joints of the PTO drive shaft. This will ensure that the PTO drive shaft will not be over extended.

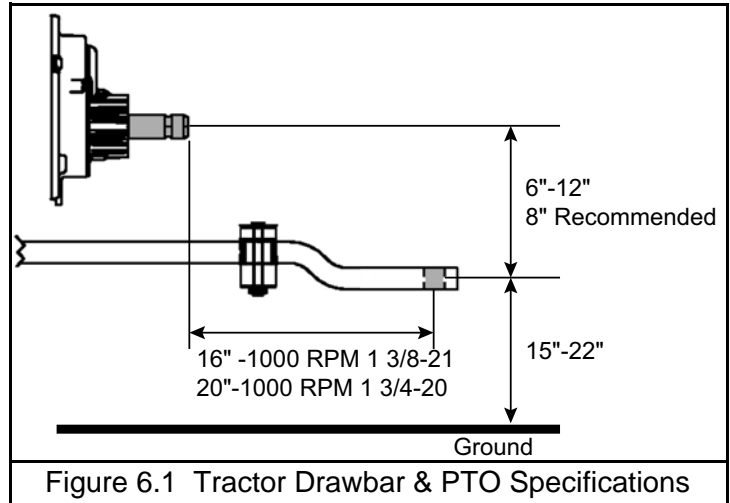

An improperly positioned hitch point may cause damage to the universal joints of the PTO drive shaft. Conforming to the standard 16" or 20" drawbar & PTO relationship will ensure that the PTO drive shaft will not become over-extended.

With initial hook-up to your implement test PTO travel by turning equipment in both directions observing the minimum (A) and maximum (B) travel dimensions.

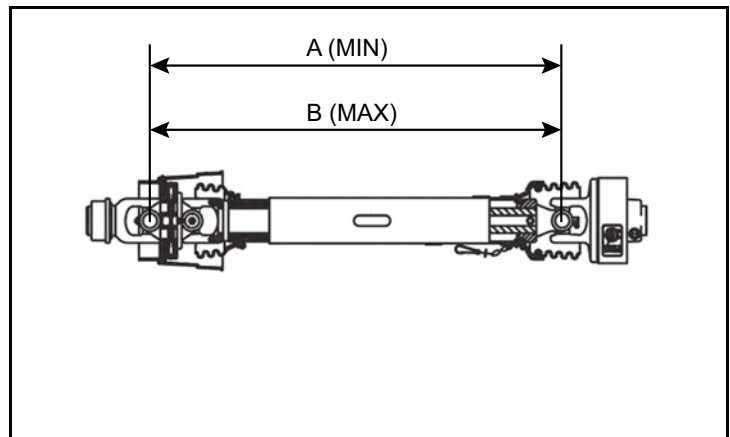

PTO PART NUMBER	A	B
118-VM-0024-55	38.19"	50.98"
118-VM-0023-55	38.19"	50.98"

6.6 HITCHING TO TRACTOR



Do not allow anyone to stand between the tongue or hitch and the tractor when backing up to the implement.

Before hitching to the tractor, make sure that there is sufficient ballast on the front axle of the tractor.

Depending on conditions, the ballast weight needs to be adjusted to optimize tractor drive. The front axle load must never, under any circumstances, be less than 20% of the tractor's unladen weight.

Move to the operator's position, start the engine and release the parking brake.

Move the tractor in front of the mixer. Slowly move the tractor backwards towards the mixer and align the drawbar with the implement's hitch.

Note: Lower or raise the mixer jack to properly align the drawbar and hitch.

Fasten the forage box hitch to the tractor drawbar with a properly sized hitch pin with safety retainer. (Reference ANSI/ASABE AD6489-3 Agricultural vehicles - Mechanical connections between towed and towing vehicles - Part 3: Tractor drawbar.) (See your Trailer / Chassis manual for further details.)

Before operation and after hitching the tractor to the implement, connect the hydraulic hoses and light cord to the tractor. Connect any optional equipment as needed.

6.6.1 Jack Storage

After hitching the mixer or the tractor.

Using the handle, raise the jack off the ground and remove the pin. Move the jack to the storage mount (Item 1) located on the back left hand side of the mixing tub. Reinstall the pin to lock the jack into the transport position.

Note: Keeping jack stored in proper position will keep it from getting damaged during transportation.

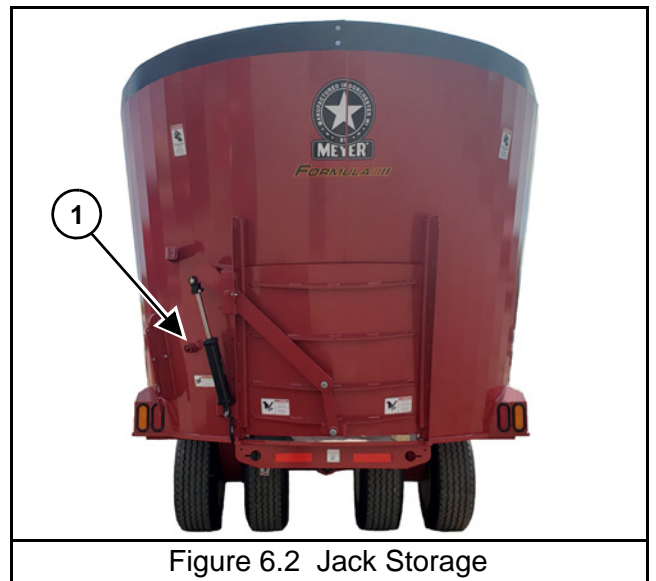

Figure 6.2 Jack Storage

6.7 START-UP AND SHUT-DOWN



WARNING

Disengage electric/ hydraulic power, engage the machine's parking brake, stop the engine and make sure all moving components are completely stopped before connecting, disconnecting, adjusting or cleaning this equipment.

Always keep all shields and guards in place and securely fastened.

Keep hands, feet and clothing away from moving components.



CAUTION

Shutoff and lockout power before adjusting, servicing, maintaining, or clearing an obstruction from this machine. Refer to section 5.3 SHUTOFF & LOCKOUT POWER.

DO NOT allow anyone to operate, service, inspect or otherwise handle this implement until all operators have read and understand all of the instructional materials in this Owner / Operator's and Parts Manual and have been properly trained in its intended usage.

Before operating the implement, look in all directions to ensure there are no bystanders, especially small children, in the work area.

6.7.1 Start-Up

1. Be sure there is no one inside the mixer and the mixer is empty.
2. Enter the tractor and start the engine.
3. Set the parking brake.
4. Check to see that the discharge door is closed.
5. Slowly engage the PTO and operate at idle speed.
6. Bring PTO RPM up to its rated RPM.

6.7.2 Shut-Down

1. Disengage the PTO.
2. Turn off conveyor, if equipped.
3. Fully lower all doors.
4. Raise slide trays or conveyors, if equipped.
5. Park the mixer on a flat, level surface.
6. Engage the parking brake, stop the engine and exit the tractor.

6.8 OPERATIONAL CHECKS



Always keep all shields and guards in place and securely fastened. Keep hands, feet and clothing away from moving components.



Shutoff and lockout power before adjusting, servicing, maintaining, or clearing an obstruction from this machine. Refer to section 5.3 SHUTOFF & LOCKOUT POWER.

DO NOT allow anyone to operate, service, inspect or otherwise handle this implement until all operators have read and understand all of the instructional materials in this Owner / Operator's and Parts Manual and have been properly trained in its intended usage.

Before operating the implement, look in all directions to ensure there are no bystanders, especially small children, in the work area.



Once PTO has been disengaged and a change of auger speed has been selected, allow at least 5 seconds for the stop & shift gearbox to complete the shift process before engaging PTO.

Before running material through the mixer for the first time and each time thereafter, follow these steps:

1. Follow the Start-Up procedure section 6.7.1 Start-Up.
2. Raise and lower the door several times.
3. Lower and raise mixer slide trays or conveyors, if equipped.
4. Operate the mixer augers and conveyors, if equipped, for approximately 5-10 minutes. If mixer is equipped with a stop & shift gearbox or power shift transmission:

Stop & Shift Gearbox: Stop the tractor PTO. Once the PTO has completely stopped, shift the stop & shift gearbox to high. Wait 5 seconds. Engage the tractor PTO and bring RPM back up to operating speed for the last minute of test run time.

Power Shift Transmission: Shift the power shift transmission into high for the last minute of test run time.

5. Follow the Shut-Down procedure section 6.7.2 Shut-Down.
6. Check drive components to be sure components are not abnormally hot.
7. Check all hydraulic components for leaks.
8. Adjust and lubricate equipment as needed. See Section 8.3 ADJUSTMENTS and Section 8.2 LUBRICATION.

6.8.1 Controls

6.8.1.1 Stop & Shift Gearbox

IMPORTANT

Once PTO has been disengaged and a change of auger speed has been selected, allow at least 5 seconds for the stop & shift gearbox to complete the shift process before engaging PTO.

A control box is provided with the mixer. There is a single 2-position switch, one position to shift to “Low” (Item 1) and one to shift to “High” (Item 2). Mixers equipped with a stop & shift gearbox will automatically begin the shift process after selecting a different speed and the PTO has stopped to prevent damage to the gearbox. Once PTO has been disengaged and a change of auger speed has been selected, allow at least 5 seconds before engaging PTO.



Figure 6.3 815/1015/1215 Control Box

6.8.1.2 Power Shift Transmission

A remote control is provided with the mixer. There are 2 switches, one to shift to “Low” (Key 1) and one to shift to “High” (Key 2). The power shift transmission will only shift to “High”, once selected, if the PTO RPM is at 650RPM. The “High” speed light (Key 3) will light up indicating the power shift transmission is in “High” speed.



Figure 6.4 Remote



Figure 6.5 “High” Speed Indicator Light

6.9 TRANSPORTING

CAUTION

- DO NOT allow anyone to operate, service, inspect or otherwise handle this implement until all operators have read and understand all of the instructional materials in this Owner/ Operator's and Parts Manual and have been properly trained in its intended usage.
 - Before operating the implement, look in all directions to ensure there are no bystanders, especially small children, in the work area.
 - No riders allowed when transporting.
 - Do not drink and drive.
 - Before moving, be sure required lights and reflectors are installed and working.
 - Before maintenance or repair, stop vehicle, set parking brake, and remove ignition key.
 - Place safety stands under frame and chock wheels before working on tires or chassis.
 - Maintain wheel bolts at torque as recommended in the manual.
 - If equipped with brakes, maintain proper adjustment.
-

CAUTION

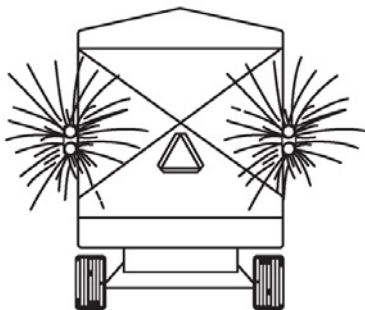

PULL-TYPE UNITS

- Use flashing warning lights when transporting on ALL highways (public roadways) at ALL times (Tractor towed models) EXCEPT WHEN PROHIBITED BY LAW! (Check w/local law enforcement).
 - Adhere to all state and federal laws. Implement lights do not replace the SMV (Slow-Moving Vehicle) identification emblem. All towed agricultural vehicles must display SMV emblems when traveling LESS than 20 mph (32 kph).
 - Check for traffic constantly. Be sure you can see that no one is attempting to pass you and that all traffic is sufficiently clear from you before making any turns.
 - Securely attach to towing unit. Use a high strength appropriately sized hitch pin with mechanical retainer and attach safety chain.
 - Do not exceed 20 mph (32 kph). Slow down for corners and rough terrain.
-

WARNING



- Shift to lower gear before going down steep grades
 - Avoid traveling on slopes or hills that are unsafe
 - Keep towing vehicle in gear at all times
 - Never exceed a safe travel speed (may be less than 20 MPH)
-

WARNING

You must observe all applicable traffic laws when transporting on public roadways. Check local laws for all highway lighting and marking requirements.

(Tractor Powered) Do not tow at speeds in excess of 20 mph.

IMPORTANT

Verify that the rear discharge door is in the closed position before traveling on roadways.

If you will travel on public roads and it is legal to do so, you must know all rules governing such operation. This will include lighting and brake requirements in addition to traffic rules.

Note: *An optional highway lighting package is available to assist in meeting these requirements. See your Meyer dealer for details.*

6.9.1 Safety Chain

The chain must be of adequate size to hold the weight of the loaded implement.

Note: *If using a grab hook at the end(s) of the chain to secure the chain to itself, a hook latch (Item 1) must be installed.*

The length of the safety chain is not to be any longer than necessary to turn without interference. If any chain links or attachment hardware are broken or stretched, repair before using. Store chain so it does not corrode or become damaged. Do not use this chain for other implements because the strength and length of the chain may not be adequate. Identify this chain for use on this particular implement.

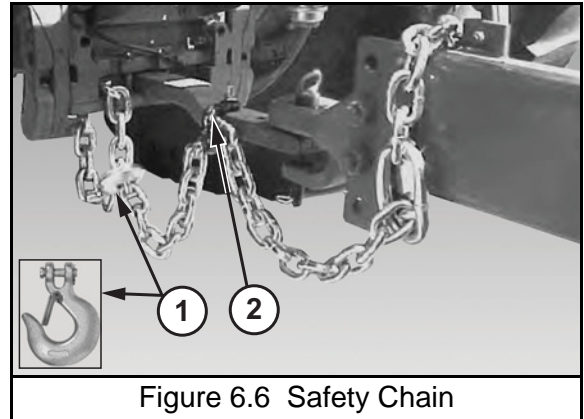

Figure 6.6 Safety Chain

Note: *Do not use the intermediate support (Item 2) as the attaching point.*

IMPORTANT

If you do not have a safety chain, or a replacement safety chain is needed, see your local Meyer dealer and do not operate on public roads until you are able to travel with the safety chain properly installed.

6.9.2 Tractor Towing Size Requirements

Use the following charts to help calculate the minimum tractor weight when towing without implement brakes. The minimum tractor weight, up to 20 mph (33 kph) needs to be two thirds of the box Gross Weight (GW). Gross Weight is calculated by the empty weight of the box and undercarriage combined added to the Load Weight. Then take the Gross Weight and multiply it by 0.667 and you will get the Minimum Required Weight of the Tractor. A tractor with this recommended weight for your machine is normally adequate for towing the loaded machine under average conditions.

Note: *Implement Loaded Weight x 0.667 = Minimum Tractor Weight Up to 20 mph*

Model	MAXIMUM IMPLEMENT GROSS WEIGHT (LBS)	MINIMUM TRACTOR WEIGHT UP TO 20 MPH (LBS)

6.9.3 Brake Information (Optional)

A brake system is recommended for any mixer operated on public roads and may be a requirement.

6.9.3.1 Pedal Operated Hydraulic Brakes



At no time should the brake system be used as a parking brake. With loss of hydraulic pressure, the brakes will lose their holding power.

This brake system is a one hose system. The single hydraulic hose must be connected to the tractor remote pedal port.

Applying The Brakes - Gradually apply the tractor brake pedal to apply the brakes.

Releasing The Brakes - Release the tractor brake pedal to release the brakes.

6.10 OPTIONAL EQUIPMENT

Refer to scale indicator (Item 1) manufacturer’s operators manual for operation.

See 8.5.2 Digital Scale Indicator for additional scale maintenance information.

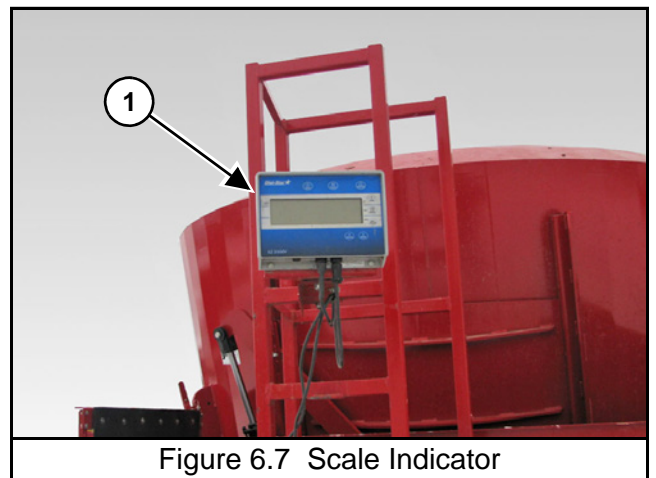
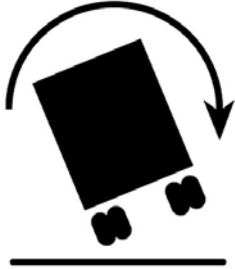

Figure 6.7 Scale Indicator



7.0 OPERATION

CAUTION



- **DO NOT** allow anyone to operate, service, inspect or otherwise handle this implement until all operators have read and understand all of the instructional materials in this Owner/ Operator's and Parts Manual and have been properly trained in its intended usage.
- **Before operating the implement, look in all directions to ensure there are no bystanders, especially small children, in the work area.**
- **Do not climb or step on any part of the implement at any time.**
- **Turn on level ground. Slow down when turning.**
- **Go up and down slopes, not across them.**
- **Keep the heavy end of the machine uphill.**
- **Do not overload the machine.**
- **Check for adequate traction.**

7.1 GENERAL

IMPORTANT

Always operate at the rated PTO speed but **DO NOT EXCEED THE RATED PTO SPEED**. If the mixer is operated faster than the rated PTO speed the strain on the drive train and mixer is greatly increased.

Do not force hay into the auger with loader or any other device.

Be aware of the overall size of the mixer to allow clearance through doorways.

The mixer is designed for blending dairy and beef rations. The mixer performance can vary according to the difference in material, loading sequence, mixing speed and unloading methods. The following guidelines should be understood before operating the mixer.

A new mixer will need an initial run-in period to polish the augers and mixer sides to achieve correct material movement inside the mixer. Until the unit is polished inside the user may experience material spillage, dead spots, or increased horsepower requirements. The load size may need to be reduced until the unit is polished inside.

7.1.1 Material



Never hand feed material into mixer while it is running. Augers may cut or grab hands, clothing or material being loaded. Always stop the tractor's engine before hand loading materials.

Some feed materials will need to be processed alone in the mixer before they can be efficiently mixed with other feed materials.

- Large square or round bales of alfalfa
- Large square or round bales of high moisture content
- Large square or round bales of long mixed grasses, wheat or oat hay
- Large square or round bales of crop residue such as straw or soybean stubble
- Very light and bulky feed material

NOTE: Always remove any twine, net or plastic wrap from bales before loading into mixer.

7.1.2 Cutout Clutch

The clutch is designed to limit the amount of torque transferred to the machine through the driveline. If excessive torque is developed the clutch will disengage. A loud ratcheting sound will be heard and the transfer of power to the machine will be disrupted. This may occur when mixing or unloading a heavy mix or if an obstruction has lodged within the mixer. This is to protect the driveline from damage. To re-engage the machine, simply shut down the PTO and allow the driveline to come to a stop. The PTO can then be re-engaged to restart the mixer. The cutout clutch will either re-engage upon shut down of the PTO or just before it comes to a complete stop.

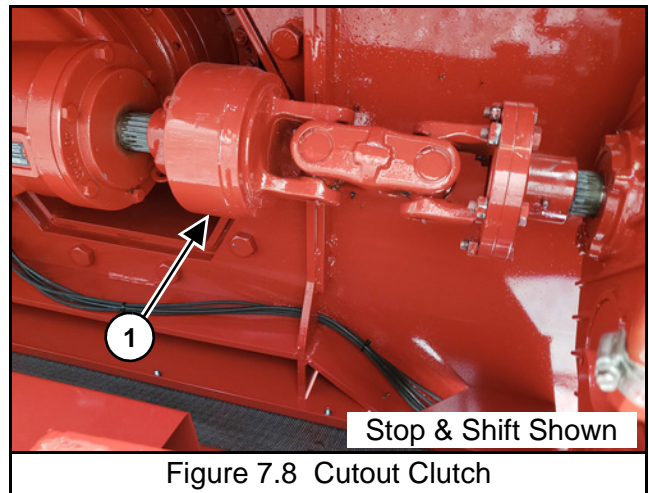

Figure 7.8 Cutout Clutch

7.2 LOADING



DO NOT ENTER MIXING CHAMBER WHILE MIXER IS RUNNING! Shutoff and lockout power before attempting to clear an obstruction or to perform work inside the mixing chamber. Refer to section 5.3 SHUTOFF & LOCKOUT POWER.



Be aware of power lines and other overhead obstructions when loading with a telescopic arm or loader.



Shutoff and lockout power before adjusting, servicing, maintaining, or clearing an obstruction from this machine. Refer to section 5.3 SHUTOFF & LOCKOUT POWER.

Comply with the safety instructions stipulated in the User Manuals for the operation / handling equipment used for loading the mixer.

Do not climb or step onto the platform or ladder before the parking brake has been applied.

When loading from a raised bay or platform, adopt the necessary measures (safety rails, etc.) to avoid people or equipment from falling into the machine.



Overloading may cause failure of axles, tires, structural members, hitches, loss of vehicle control. **DO NOT** exceed maximum gross weight.

NOTE: *Overloading can have detrimental effects on the integrity of the implement and it's safe use. Overloading will void warranty and increase risk to the operator's safety. Always be aware of your gross weight.*

Before loading, especially in freezing weather, make sure the augers are free to rotate and the discharge door moves freely up and down.

MATERIAL	LBS / CU.FT.
Soybeans	47 lbs.
Cotton Seed (Dry)	20 lbs.
Corn (Shelled)	45 lbs.
Corn Silage	30 lbs.
Haylage	20 lbs.
Sawdust	17 lbs.

NOTE: *Maximum Gross Weight is the lesser value between the implement or tires.*

MODEL	MAXIMUM MIXER GROSS WEIGHT	TOTAL NET WEIGHT (LBS)	CU. FT. CAPACITY**

** Struck capacity, heaped loads significantly increase weight.

When loading material into the mixer with an end-loader, dump the material into the center of the mixer.

1. Be sure that mixer is parked on a level surface.
2. The tractor should be straight in line with the mixer.
3. Completely close the mixer discharge door(s).
4. Set hay stops according to the instructions in this manual. See section 7.8 HAY STOP ADJUSTMENT.
5. Enter the tractor and start the engine.
6. Engage the PTO / hydraulics.
7. Set the tractor engine to operate at approximately 3/4 of rated PTO speed.
8. Load baled hay into the center of the mixer.
9. Allow mixer enough time to process the bale before adding other ingredients (4-10 minutes).

NOTES:

- *Processing of long stem forages will continue as other materials are added and mixed. Be careful not to over process these materials before adding other ingredients.*
- *Mixers equipped with a stop & shift gearbox or power shift transmission can process roughages in “Low” or “High” depending on how fast the bale needs to be processed. Mix all other materials in “Low”.*

7.2.1 Loading Sequence

IMPORTANT

Load all ingredients as quickly as possible. Allow a final mix time of 3-7 minutes, or whenever the load looks consistently mixed.

Never load long stem bales last. They will not be processed or mixed into the ration and may cause unloading difficulties or spillage.

NOTE: *The loading sequence could vary.*

The following is an example of a typical loading sequence:

1. Load and process long stemmed materials.
2. Load haylage and corn silage.
3. Load minerals, proteins and other small quantity ingredients.
4. Load grains, wet and dry commodities, etc.
5. Load all liquid fats, water and other liquids. Always load liquids at the center of the mixing chamber.

7.3 MIXING



DO NOT ENTER MIXING CHAMBER WHILE MIXER IS RUNNING!
Shutoff and lockout power before attempting to clear an obstruction or to perform work inside the mixing chamber. Refer to section 5.3 SHUTOFF & LOCKOUT POWER.

IMPORTANT

Always operate at the rated PTO speed but **DO NOT EXCEED THE RATED PTO SPEED.** If the mixer is operated faster than the rated PTO speed the strain on the drive train and mixer is greatly increased.

Do not force hay into the auger with loader or any other device.

Normal mixing speed is 3/4 to full rated PTO speed. Time available to mix, thoroughness of the mix, and ingredients are all factors that must be considered when deciding on when and how fast to operate the mixer.

7.4 PLATFORM OPERATION

Park the tractor on a flat, level surface.

Engage the parking brake.

NOTE: Always maintain a three-point contact at all times when getting on and off the ladder. Use the ladder rails and steps when climbing the ladder.

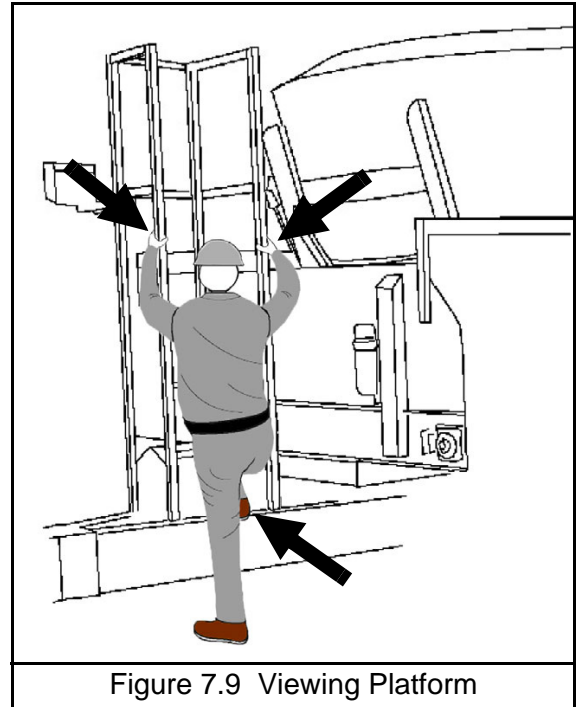

Figure 7.9 Viewing Platform

7.5 FOLDING LADDER

To unfold the ladder, release latch (Item 1) and pull ladder fully out (Item 2). To return ladder to storage position, pull ladder out to “unlock” it and guide the ladder support back up to its original position. Replace latch.

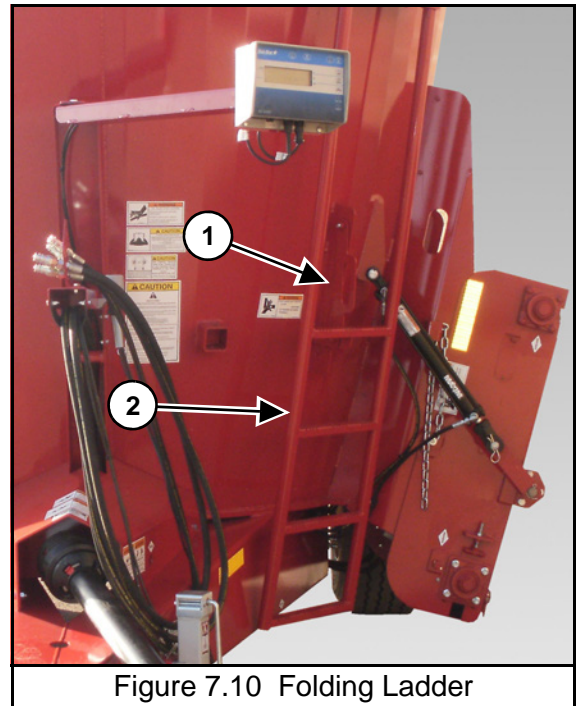

Figure 7.10 Folding Ladder

7.6 UNLOADING



DANGER

DO NOT ENTER MIXING CHAMBER WHILE MIXER IS RUNNING! Shutoff and lockout power before attempting to clear an obstruction or to perform work inside the mixing chamber. Refer to section 5.3 SHUTOFF & LOCKOUT POWER.



CAUTION

Shutoff and lockout power before adjusting, servicing, maintaining, or clearing an obstruction from this machine. Refer to section 5.3 SHUTOFF & LOCKOUT POWER.

IMPORTANT

Once PTO has been disengaged and a change of auger speed has been selected, allow at least 5 seconds for the stop & shift gearbox to complete the shift process before engaging PTO.

NOTE: Unload the mixed ration within a short time of mixing. A fully loaded mixer which is bounced over rough terrain or allowed to settle will require more horsepower during start-up.

1. Enter the tractor, start the engine, release the parking brake.
2. Move the tractor and mixer to the unloading area.
3. Be sure that mixer is parked on a level surface.
4. The tractor should be straight in line with the mixer.
5. Shift front sliding conveyor into working position or lower slide tray / conveyor (if equipped).

NOTE: Mixers equipped with a power shift transmission will automatically shift to low if the PTO RPM drops below 600 RPM while in "High".

6. For mixers equipped with a stop & shift gearbox, shift the gearbox into "Low" to ease the start of a full load for unloading.
7. Engage the PTO.
8. Set the tractor engine to operate at approximately 1/2 of rated PTO speed.
9. Open discharge door slowly to adjust the amount of material to be discharged. Adjust door height or conveyor speed for desired flow of feed.
10. After the load begins to discharge, increase the tractor RPM to full rated PTO speed to ensure fast and thorough clean out while driving forward along the discharge path.
11. During the unloading process, the mixer can be shifted into "High". See section 6.8.1 Controls for more details. This will help remove any feed remaining on the augers and assist in keeping an even flow until the mixer is empty.
12. When finished unloading, reduce engine speed to idle and disengage the PTO / hydraulics.
13. Move the mixer forward, away from the unloaded material.
14. Close the discharge door.
15. Shift front sliding conveyor into storage position or raise slide tray / conveyor (if equipped).
16. Park the mixer on a flat, level surface.
17. Engage the parking brake, stop the engine and exit the tractor.

7.7 UNHOOKING THE TRACTOR



Keep hands, legs and feet from under tongue and hitch until jack is locked into place.

Jack is not designed to support the implement when it is loaded.

1. Park the implement on level ground. Put the tractor controls in neutral, set the parking brake, and turn the engine off before dismounting.
2. Place wheel chocks in front and in back of the implement wheels on opposite sides to prevent the implement from rolling after the tractor is unhooked.
3. Disconnect the PTO drive shaft.
4. Remove the hydraulic hose ends from the tractor hydraulic ports and secure the hose ends in the key slot holes on the front of the mixer to keep them clean.
5. Remove the light cords and any optional equipment connections.
6. Remove the jack from the storage mount and reinstall the jack on the hitch tongue. Crank the jack down until the hitch lifts off the tractor drawbar.
7. Remove the hitch pin.
8. Unhook safety chain from tractor drawbar and intermediate support.
9. Slowly drive the tractor away from the implement.

7.8 HAY STOP ADJUSTMENT

CAUTION

DO NOT adjust the hay stops while the mixer is running. Moving feed inside the mixer can make the hay stop move suddenly causing injury to the person making the adjustment.

IMPORTANT

Never operate the mixer without the hay stop lock bolt installed.

7.8.1 Hay Stop Lock Bolt

The hay stop lock bolt (Item 1) prevents the hay stop from rotating past the intended range of operation. If the hay stop and the positioning pin (Item 2) are removed, the hay stop could contact the moving auger and cause damage to the hay stop and auger.

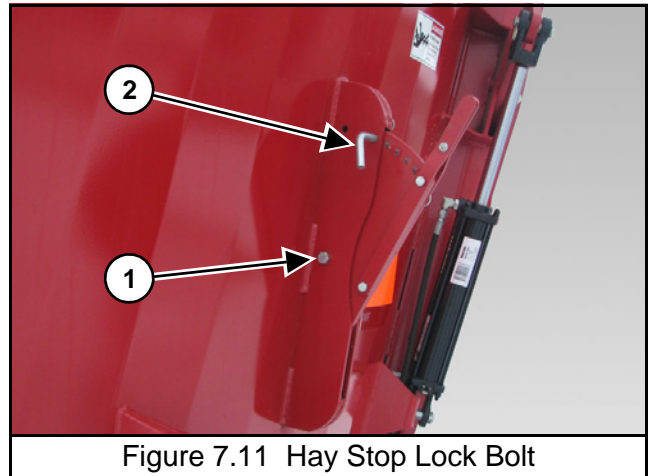

Figure 7.11 Hay Stop Lock Bolt

Position	Setting	Material
A	High	Light And Bulky Material (Dry Grasses)
B	Medium High	Alfalfa Bales And Other Forages
C	Neutral	Unrestrained Movement Of Feed
D	Medium Low	Heavier Rations
E	Low	Aggressive Cutting

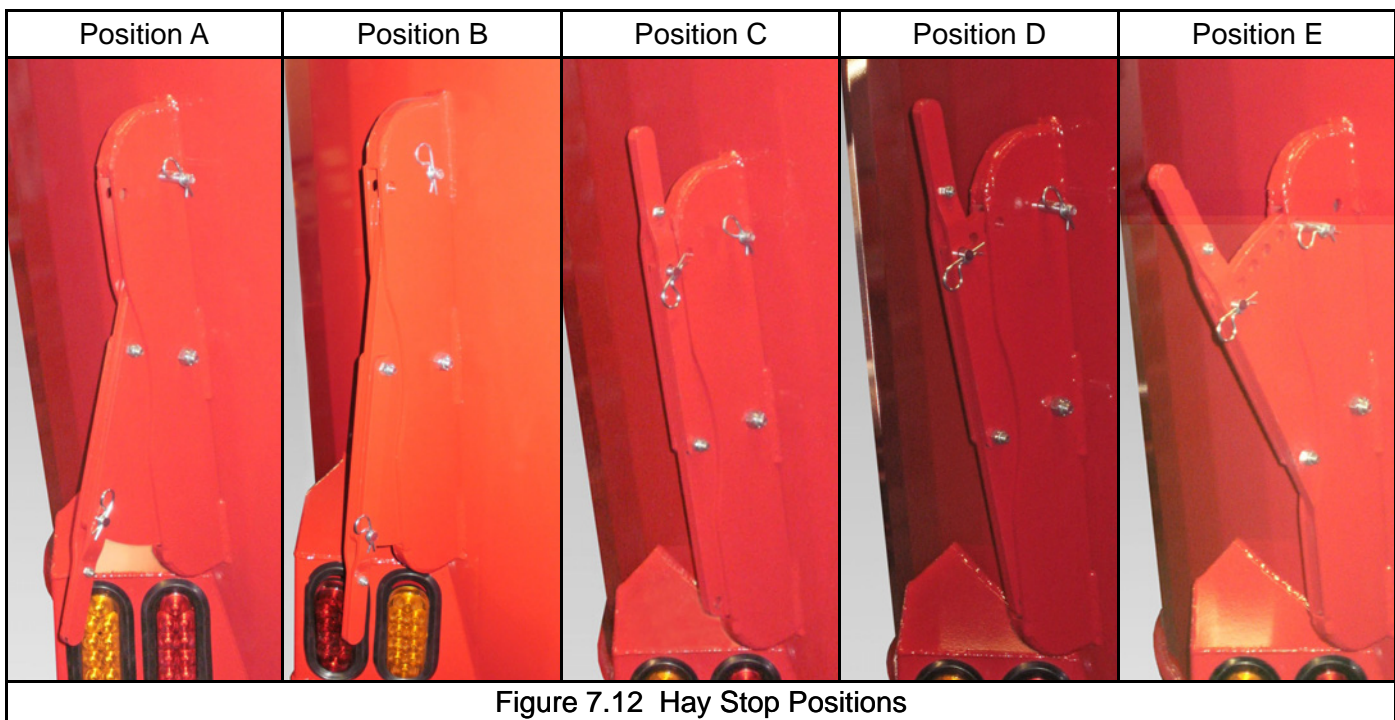

Figure 7.12 Hay Stop Positions

7.9 MIXER TROUBLESHOOTING GUIDE

PROBLEM	POSSIBLE SOLUTIONS
Forage Is Cut Too Short	<ul style="list-style-type: none"> • Reduce the initial processing time. • Adjust hay stops to a less aggressive or neutral position. • Reduce total loading time. • Reduce the mixer RPM to limit aggressiveness in processing. • Modify the knife type, quantity, setting or placement. • Shift stop & shift gearbox or power shift transmission into “Low”.
Spillage Is Occurring	<ul style="list-style-type: none"> • Reduce Load Size. • Reduce tractor and/or mixer RPM. • Make sure machine is level. • The load size may need to be reduced until the unit is polished inside. • Adjust hay stops to a less aggressive or neutral position. • Adjust knives to a less aggressive position. • If spillage still occurs, the optional side extensions or hay retention ring may need to be installed.
Requiring High Horsepower	<ul style="list-style-type: none"> • Reduce load size. • Adjust hay stops to a less aggressive or neutral position. • The load size may need to be reduced until the unit is polished inside. • Modify the knife type, quantity, setting, or placement. • Shift mixer into “Low”.
Dead Spots	<ul style="list-style-type: none"> • The load size may need to be reduced until the unit is polished inside. • The auger scraper may need to be adjusted. (See Section 8.3.5 Auger Scraper Plate)
Digital Scale Indicator	<ul style="list-style-type: none"> • Refer to scale manufacturer’s operator manual for operation and maintenance. • Some scale drift may occur after the scale is turned on but should level out within 10 to 15 minutes. • Temperature changes may also cause some drifting.
Planetary Reservoir Is Overflowing or Stop & Shift Reservoir Is Overflowing (If Equipped)	<ul style="list-style-type: none"> • Check oil level when cold. • Clean breather. • Make sure hoses are not kinked or clogged. • Change oil.



8.0 MAINTENANCE

8.1 GENERAL



CAUTION

Shutoff and lockout power before adjusting, servicing, maintaining, or clearing an obstruction from this machine. Refer to section 5.3 SHUTOFF & LOCKOUT POWER.

IMPORTANT

When welding do not allow electrical current to flow through bearings, roller chains, or scale weigh bars. Ground the welder directly to the part being welded. Always disconnect the power cord from scale indicator before welding.

8.2 LUBRICATION



CAUTION

Shutoff and lockout power before adjusting, servicing, maintaining, or clearing an obstruction from this machine. Refer to section 5.3 SHUTOFF & LOCKOUT POWER.

IMPORTANT

Fluid such as hydraulic fluid, grease, etc., must be disposed of in an environmentally safe manner. Some regulations require that certain spills and leaks on the ground must be cleaned in a specific manner. See local, state and federal regulations for the correct disposal.

NOTES:

- *Use a grease type that is composed of a high quality lithium complex or better, unless otherwise stated. We recommend using a #1 grade in colder temperatures or a #2 grade in warmer temperatures.*
- *We recommend using a 4-jaw grease coupling to allow greasing of both imperial and metric style grease fittings.*
- *Over lubrication is a major cause of bearing failures. Please lubricate conservatively when unsure of bearing requirements.*
- *Do not mix synthetic and mineral oils.*

8.2.1 Daily Lubrication

Check the planetary gearbox oil levels daily to prevent abnormal component wear. Add new oil to the planetary reservoir tank (See 8.2.14.1 Planetary Gearbox) if the oil level is not at the oil reservoir mark (Item 1).

Check for any oil leaks. If leaks occur, correct the source of the leak.

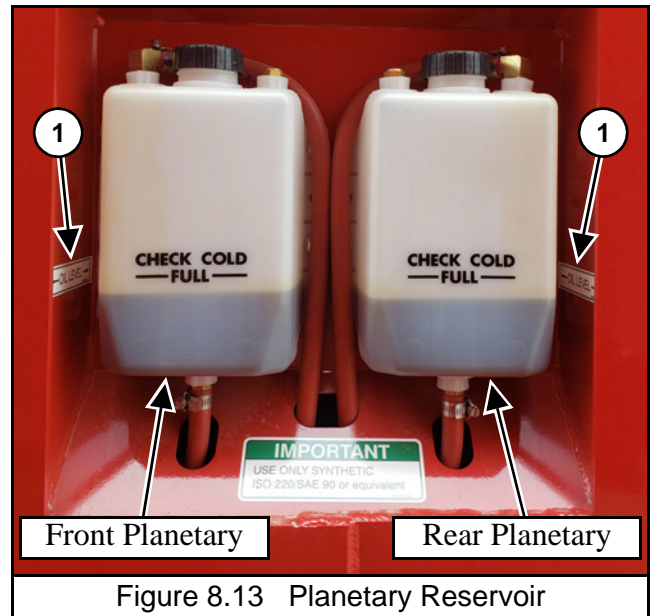

Check the stop & shift gearbox oil level daily to prevent abnormal component wear (If Equipped). Add new oil to the reservoir tank (Item 2) (See 8.2.14.2 Stop & Shift Gearbox (If Equipped)) if the oil level is not at the oil reservoir mark.

Check for any oil leaks. If leaks occur, correct the source of the leak



Check the power shift transmission oil level daily to prevent abnormal component wear. Add new oil to the transmission (If Equipped). Add new oil to the power shift transmission (See 8.1.14.3 Automatic Transmission (If Equipped)) if the oil level is not at the sight glass (Item 3).

Check for any oil leaks. If leaks occur, correct the source of the leak.

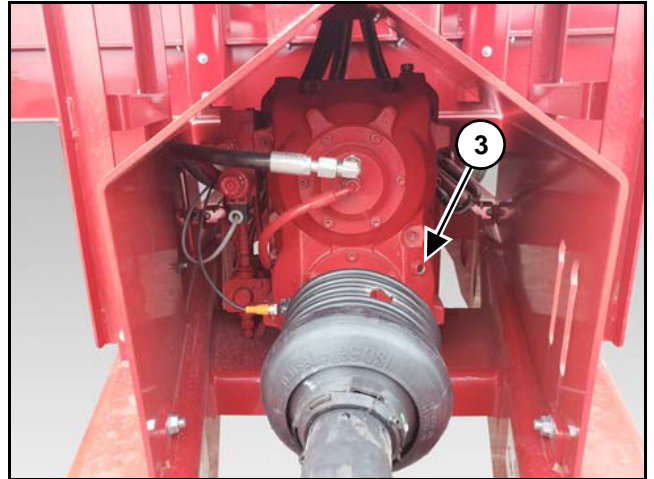

Figure 8.15 Power Shift Transmission Sight Glass

Check the oil level in each oil bath wheel hub (Item 4) (If Equipped). The oil should be 1/2" high in the sight glass (Item 5). If low, add EP80/90 gear lube through the pop out rubber plug (Item 6) at the center of the hub.

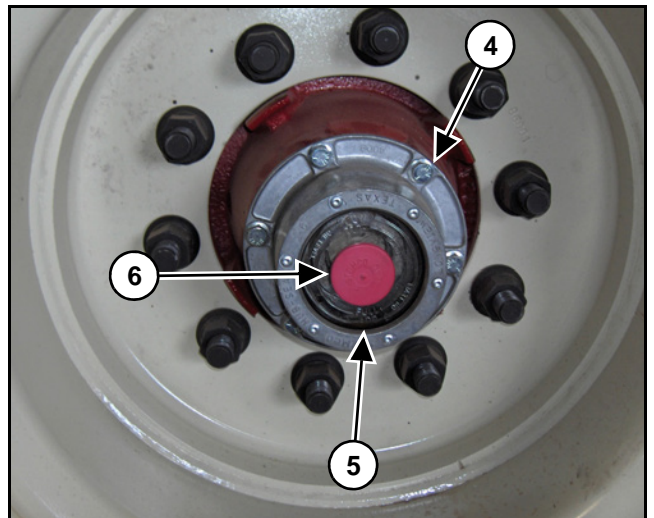
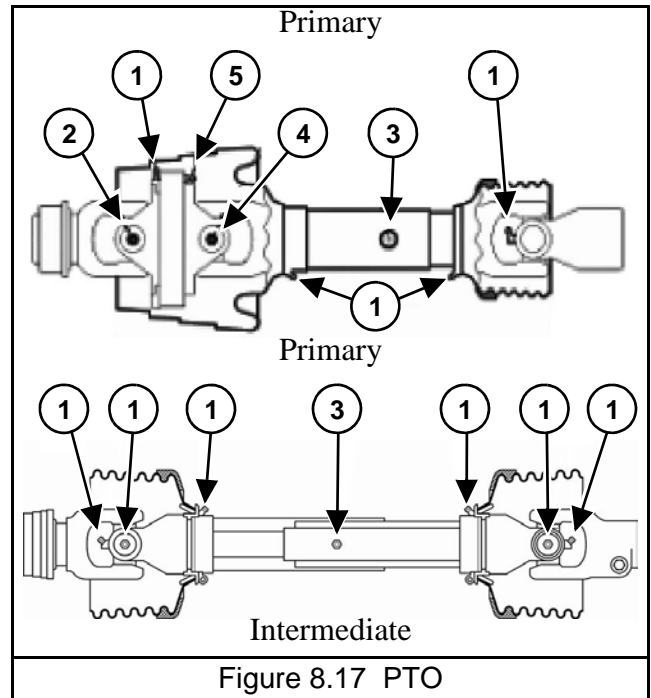

Figure 8.16 Oil Bath Wheel Hub

8.2.2 Every 8 Hours

Grease all PTO driveline zerks

1. Grease PTO locations every 8 hours.
2. Lubricate the outer CV cross kit with about 5 pumps of grease every 8 hours.
3. Grease telescoping members until it adequately covers the sliding members every 8 hours. Take apart occasionally to make sure adequate lubrication is being added. Take apart each season to be cleaned with solvent and re-coated with grease before re-assembling.
4. Lubricate the inner CV cross kit with about 15 pumps of grease every 8 hours.
5. Lubricate the double yoke with about 10 pumps of grease every 8 hours.



Grease all universal joints (Item 6) and the slide (Item 7).

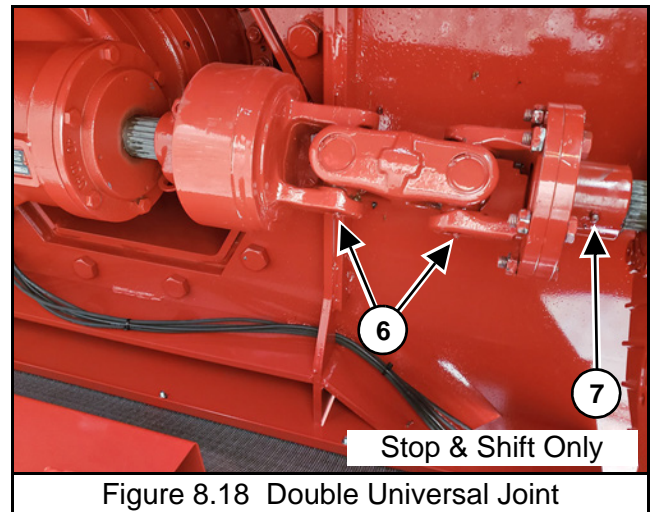

8.2.3 Monthly Lubrication

Grease the hubs through the zerk (Item 1) in each hub (If Equipped). Be careful not to over grease and force the seal out of the back side of the hub.

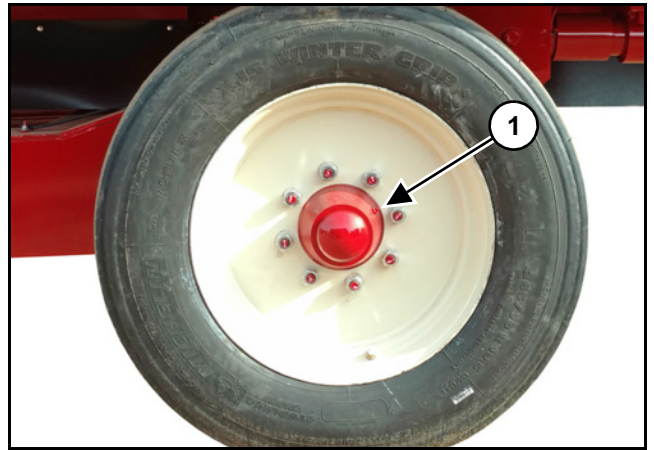

Figure 8.19 Grease Lubricated Wheel Hub

Grease the tandem inner / outer bearings (Item 2) (If Equipped).

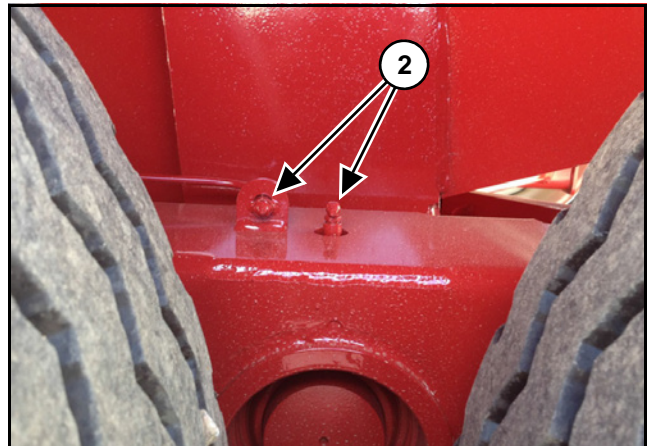

Figure 8.20 Tandem Trailer Inner/Outer Bearing

Clean out under chain return shield (Item 3) (If Equipped).

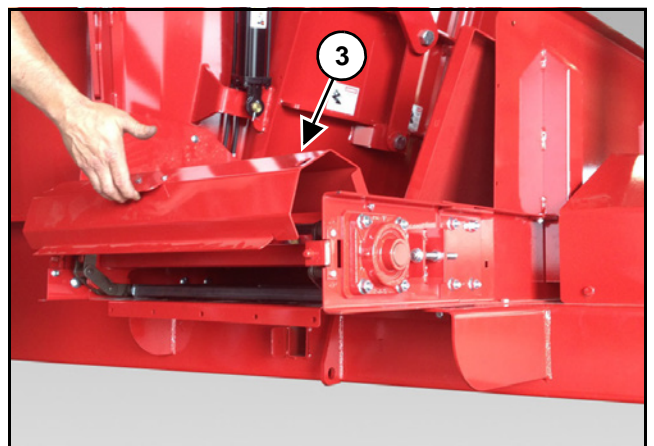

Figure 8.21 Front Chain Conveyor Return

Grease weigh bar mounts (If mounts are equipped with grease zerks).

8.2.4 Every 40 Hours

Oil door pivots (Item 1).

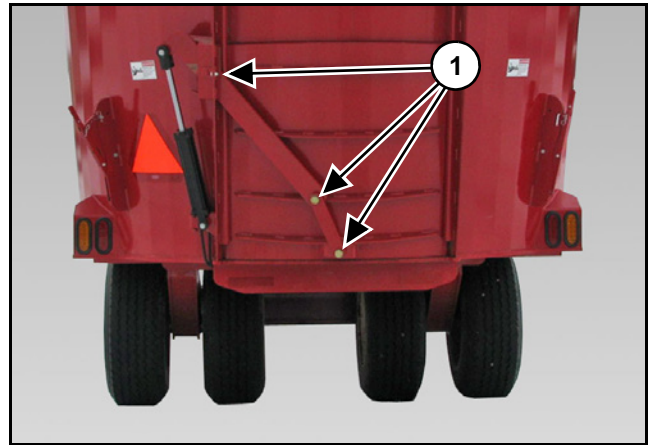

Figure 8.22 Door Pivots

8.2.5 First 50 Hours

First oil change in the planetaries (See 8.2.14.1 Planetary Gearbox).

First oil change in the stop & shift gearbox (If Equipped). (See 8.2.14.2 Stop & Shift Gearbox (If Equipped))

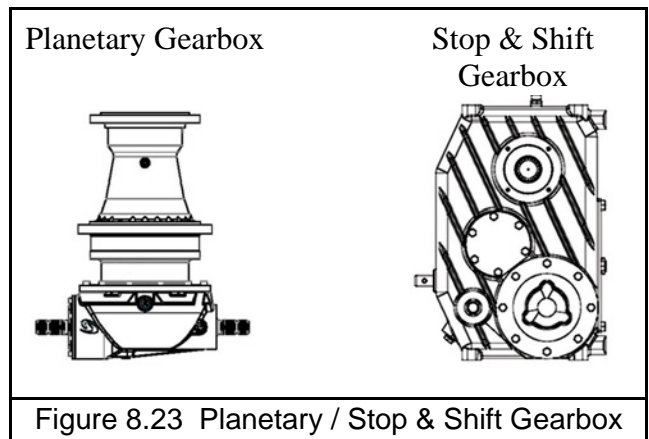

Figure 8.23 Planetary / Stop & Shift Gearbox

8.2.6 Every 250 Hours

NOTES:

- *The number of input bearings will vary depending upon your model mixer.*
- *Shielding has been removed for illustration purposes only.*

Grease all input bearings with 1 pump of grease (Item 1). Be careful not to over grease.

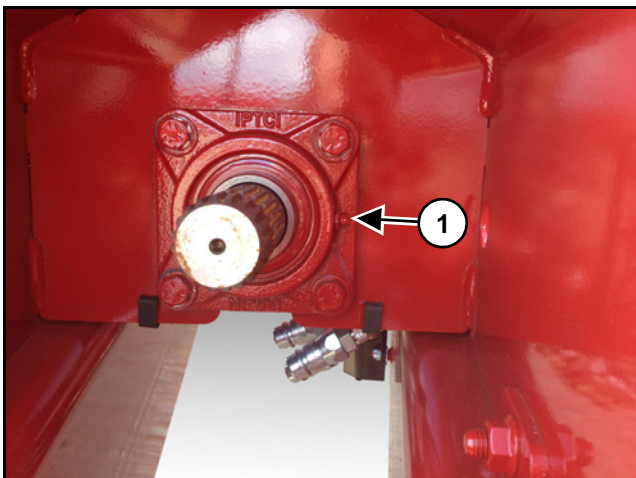

Figure 8.24 Front Input Shaft Bearing

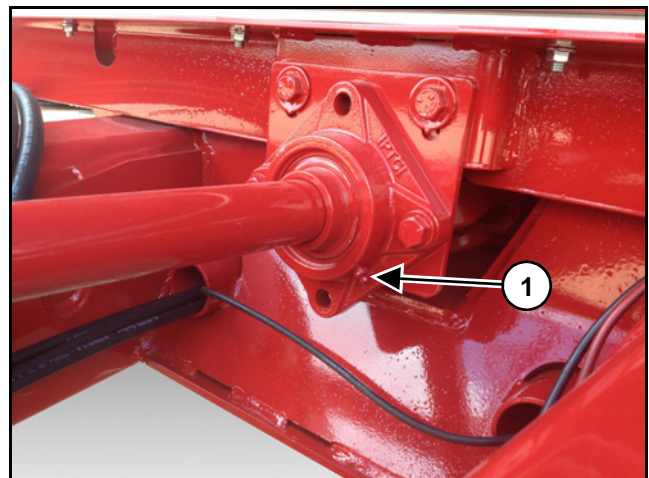
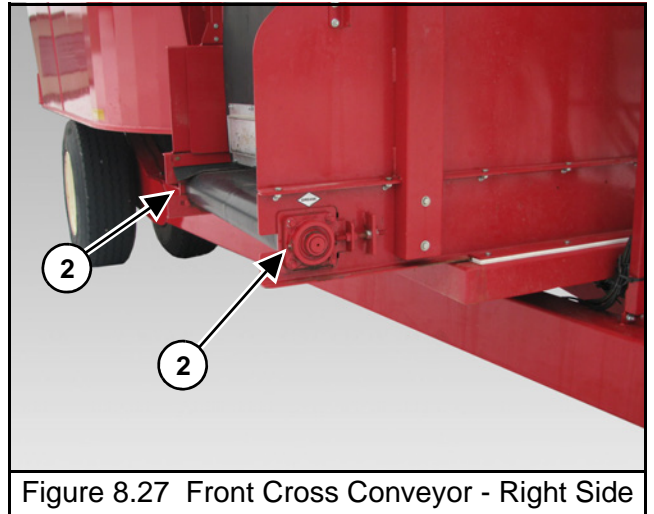
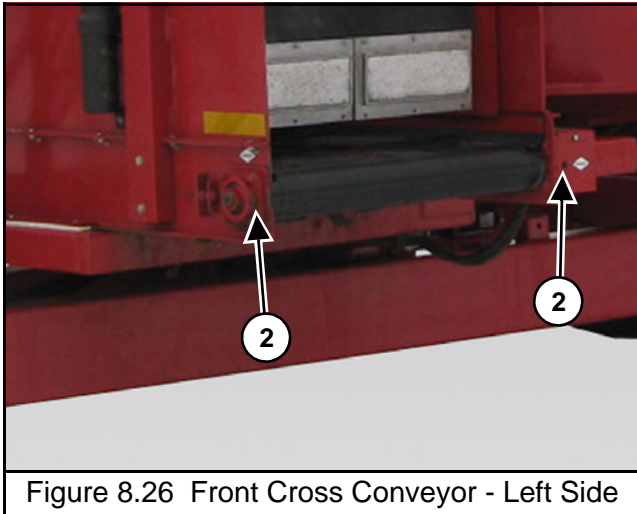
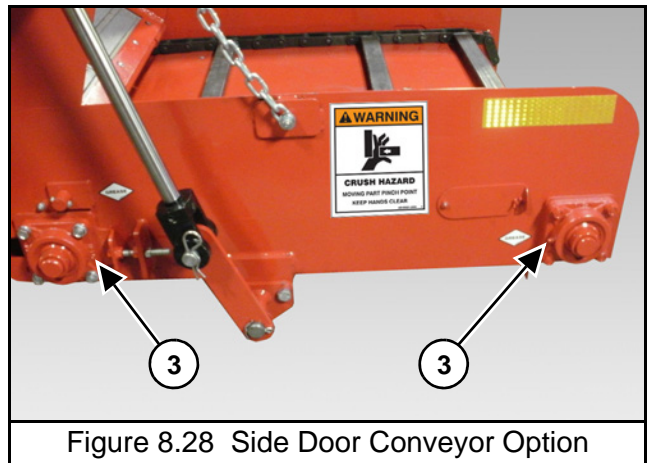

Figure 8.25 Rear Input Shaft Bearing

Grease the four (4) front cross conveyor bearings (Item 2) (If Equipped).



Grease the four (4) side door conveyor bearings (Item 3) (both sides) (If Equipped).



8.2.7 Semiannually or Every 500 - 600 Hours (Whichever Is First)

Change oil in the stop & shift gearbox (If Equipped). (See 8.2.14.2 Stop & Shift Gearbox (If Equipped))

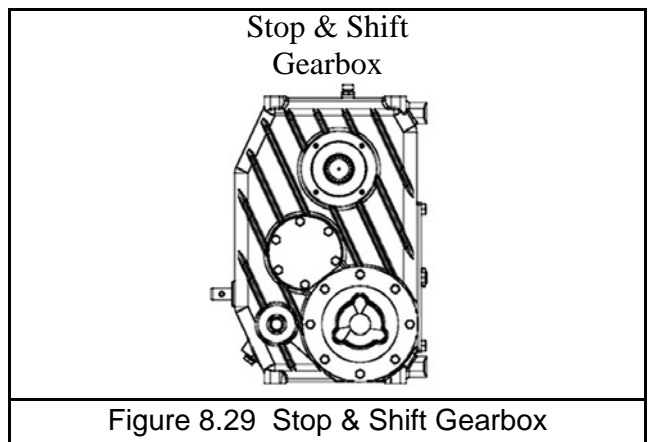

8.2.8 Annually

Clean and repack the grease lubricated wheel hubs with axle grease (If Equipped). (See 8.2.13 Grease Hubs)

8.2.9 Annually or Every 1000 Hours (Whichever Is First)

Change the power shift transmission oil and filter (If Equipped). (See 8.1.14.3 Automatic Transmission (If Equipped))

(Filter Element Part Number: 119-Z-01-1)

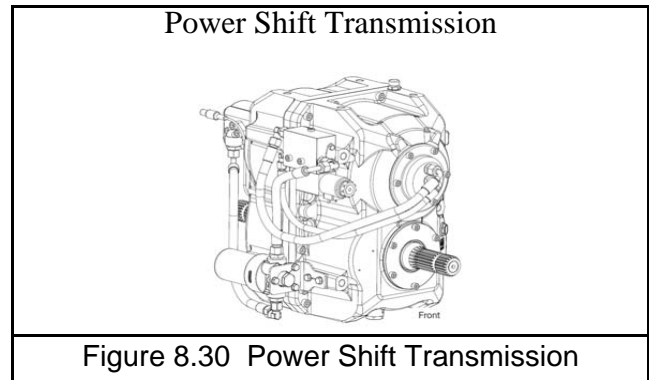

8.2.10 Annually or Every 2000 Hours (Whichever Is First)

Change oil in the planetary gearboxes. (See 8.2.14.1 Planetary Gearbox)

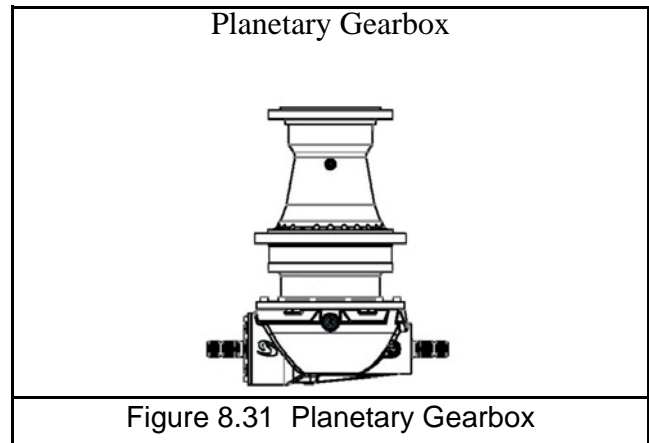

8.2.11 Every Two Years or When Discolored

Drain oil from wheel hubs (Item 1) and refill with EP80/90 oil every two years or if oil becomes discolored from water or other contamination (If Equipped).

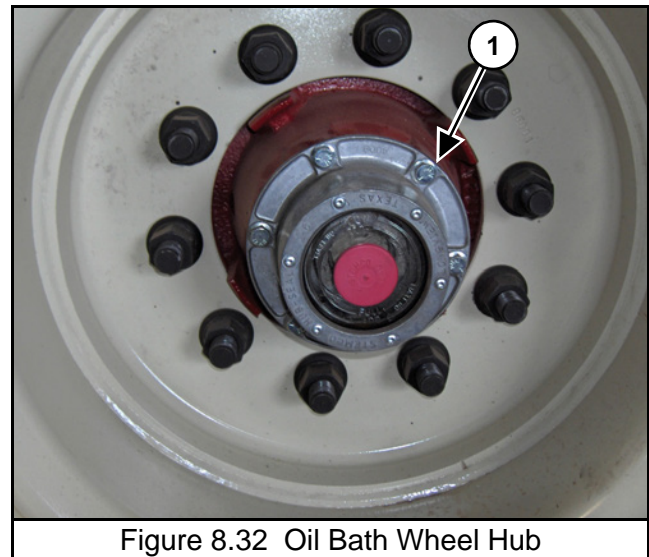

8.2.12 Every 5000 Hours

Replace all planetary bearings.

Change external planetary O-rings.

Check the extent of wear on all planetary gears.

8.2.13 Grease Hubs

- Use a pressure packer to pack the bearing cones with grease by forcing grease into the cavities between the rollers and cage from the large end of the cone. If a pressure packer is not available, pack the bearings by hand.
- Apply a light coat of grease to the spindle bearing journals.
- Pack the area of the hub between the two bearings with grease up to the smallest diameter of the bearing cups. Remove excess grease.
- Install and tighten the hub retention hardware. Apply a light coat of approved NLGI 1 or 2 grease to the hubcap interior and across the face of the outer locknut. This will indicate that NLGI 1 or 2 grease was used, as well as help prevent corrosion of these parts.

8.2.14 Gearbox/Transmission Oil & Filter Change Procedures



Shutoff and lockout power before adjusting, servicing, maintaining, or clearing an obstruction from this machine. Refer to section 5.3 SHUTOFF & LOCKOUT POWER.



Fluid such as hydraulic fluid, grease, etc., must be disposed of in an environmentally safe manner. Some regulations require that certain spills and leaks on the ground must be cleaned in a specific manner. See local, state and federal regulations for the correct disposal.

NOTES:

- *In order to avoid sludge deposits, change the oil while the gear unit is still warm.*
- *For an effective oil change, the unit should be flushed with a liquid detergent recommended by the lubricant supplier.*
- *The mixer should be level when changing gearbox oil.*

8.2.14.1 Planetary Gearbox

Draining

- Place a container of sufficient capacity under the gearbox (Item 4). Remove the planetary reservoir (Item 2) cap (Item 3).
- Drain the planetary by removing the drain plug (Item 5).
- After the planetary is completely drained, reinstall the drain plug.

Filling

Filling with an oil pump:

(Call the factory to purchase an oil pump kit, Part #: VA-OP.)

- Loosen the hose clamp and detach the lower hose (Item 1) on the reservoir (Item 2). Unbolt the reservoir and lay so the top hose and reservoir are below the lower hose used for filling (Item 1).
- Connect oil pump to the lower hose (Item 1) and fill with oil until the reservoir (Item 2) fills with approximately 2 quarts of oil. Discard this oil if it is dirty.
- Reattach the lower reservoir hose (Item 1) with the hose clamp.
- Bolt the reservoir back in place.
- Fill the reservoir to the oil level mark (Item 6) and reinstall the cap (Item 3).

NOTE: See Planetary Lubrication Specifications table for oil type and approximate capacities.

- Inspect the reservoir breather, make sure it is not plugged, and check for leaks.

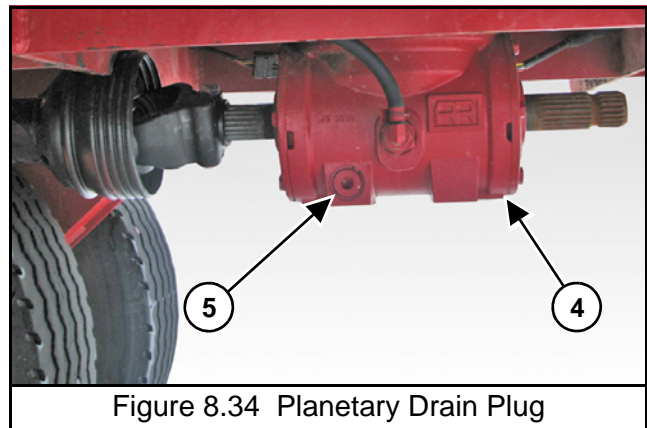
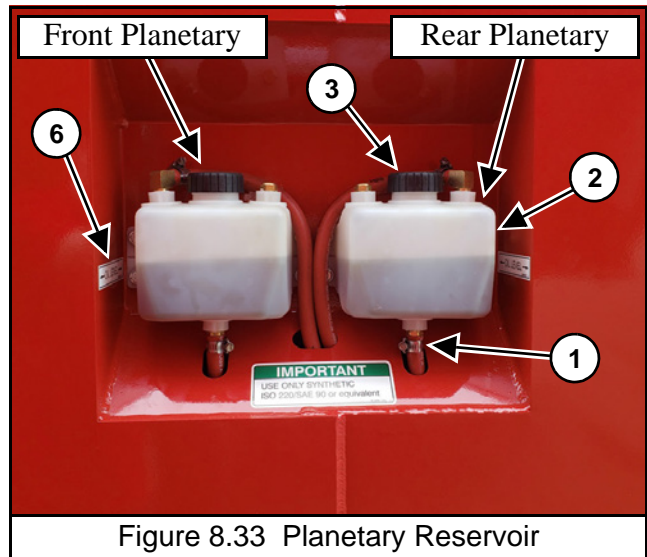

PLANETARY LUBRICATION SPECIFICATIONS				
Model	Part Number	Description	Oil Type	Capacity Per Planetary (Including Reservoir) (Approximate)
815 / 1015	119-21-25.67-1	2100 Planetary 25.67:1	Synthetic ISO 220 Or Equivalent	18.5 Quart
815P / 1015P / 1015C / 1215	119-32-24.8-1	3200 Planetary 24.8:1	Synthetic ISO 220 Or Equivalent	24.3 Quarts

8.2.14.2 Stop & Shift Gearbox (If Equipped)

IMPORTANT Check the gearbox oil levels regularly to prevent abnormal component wear. Add oil to the reservoir tank if oil level is not at the oil level mark.

Draining

- Place a container of sufficient capacity under the gearbox.
- Drain the unit by removing the plug from the bottom of the gearbox.
- After the unit is completely drained, reinstall the plug.

Filling

- Remove reservoir filler cap (Item 1) and fill with oil to the oil level mark (Item 2).

NOTE: See *stop & shift Gearbox Lubrication Specifications table for oil type and approximate capacities.*

- Replace reservoir filler cap.
- Inspect the reservoir breather, make sure it is not plugged, and check for leaks.

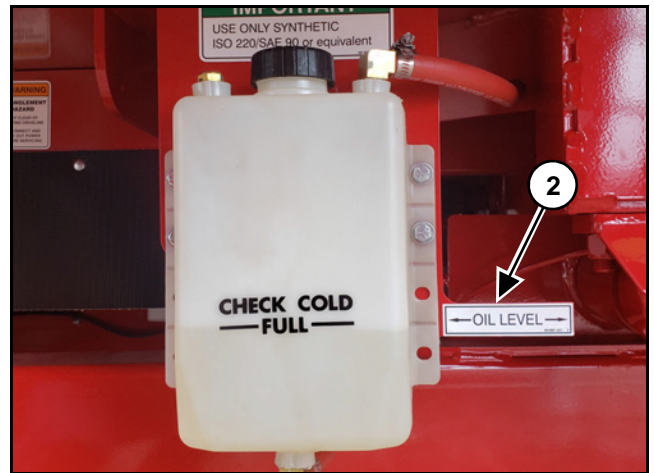

Figure 8.35 Stop & Shift Gearbox Reservoir

STOP & SHIFT GEARBOX LUBRICATION SPECIFICATIONS				
Model	Part Number	Description	Oil Type	Capacity (Including Reservoir) (Approximate)
815 / 1015	119-2SP-1.0-1.5-6	1.0:1 / 1.5:1	Synthetic ISO 220 Or Equivalent	10.5 Quart
1015P (Prior to SN 21VM1015205)	119-2SP-1.0-1.5-6	1.0:1 / 1.5:1	Synthetic ISO 220 Or Equivalent	10.5 Quart
815P / (1015P SN 21VM1015205 & Later) / 1015C / 1215	119-2SP-1.0-1.5-9	1.0:1 / 1.5:1	Synthetic ISO 220 Or Equivalent	14 Quarts

8.2.14.3 Power Shift Transmission (If Equipped)

IMPORTANT

Check the transmission oil levels regularly to prevent abnormal component wear. Add oil to the transmission if oil level is not at the oil level mark.

Draining

- Be sure the mixer is positioned on level ground/surface.
- Place a container of sufficient capacity under the transmission.
- Drain the unit by removing the plug from the bottom of the transmission.
- After the unit is completely drained, reinstall the plug.

Filter Replacement

- Remove filter housing (Item 1).
- Remove old filter.
- Lubricate the O-ring with clean oil.
- Apply aluminum paste or another suitable lubricant to the threads of the filter head and bowl.
- Place the new filter element carefully onto the element spigot.
- Screw the filter bowl on fully and then unscrew by a quarter of a turn.

Filling

- Remove breather/filler plug (Item 2).
- Fill transmission until the oil level has reached the sight glass (Item 3).

NOTE: See Power Shift Transmission Lubrication Specifications table for oil type and approximate capacities.

- Replace the breather/filler plug.
- Run the transmission with no load for a few minutes, switching from low to high gear several times.
- Check the oil level and add if necessary.
- Inspect the breather, make sure it is not plugged, and check for leaks.

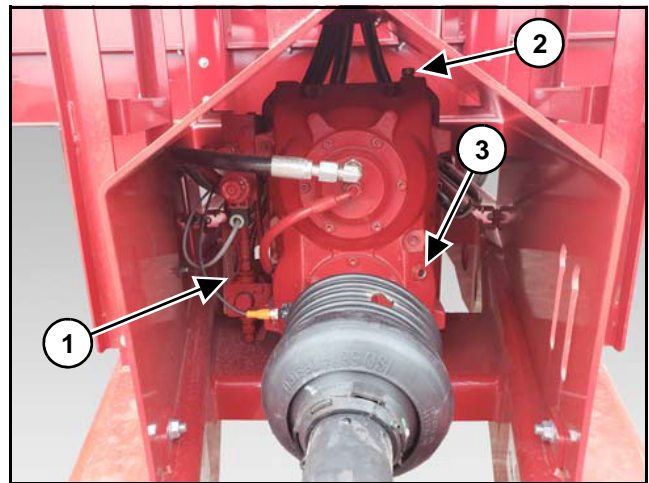

Figure 8.36 Power Shift Transmission

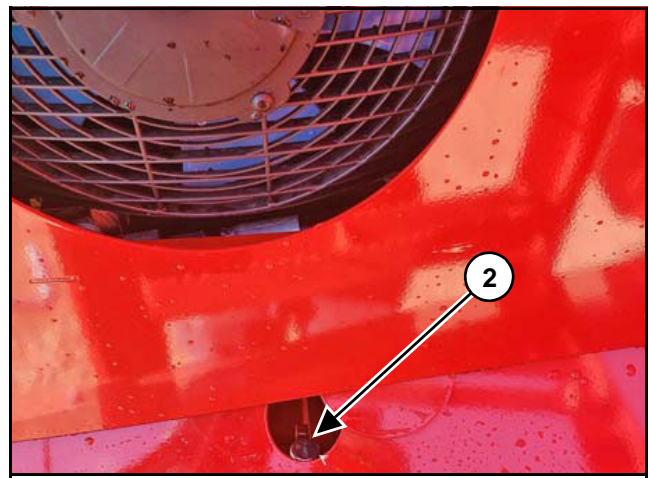

Figure 8.37 Transmission Breather/Fill Plug

POWER SHIFT TRANSMISSION LUBRICATION SPECIFICATIONS				
Model	Part Number	Description	Oil Type	Capacity (Including Radiator & Filter) (Approximate)
815P / 815C / 1015P / 1015C / 1215	119-2SP-1.0-1.8-1	1.05:1 / 1.83:1	See Approved Fluid Table	6.2 Quarts Without Cooler Drained 8.2 Quarts With Cooler Drained

POWER SHIFT TRANSMISSION FLUID (ATF) OIL						Revision: 00 Latest Update: 07-2017	
Supplier:	Product Name:	Viscosity @40°C:	Viscosity @100°C:	Viscosity Index:	Pour Point:	STATUS	
						Recommended	Approved
AGCO	AGCO POWER FLUID 411 ATF SAE 5W-20	35	7.2	174	-48°C		X
CASTROL	CASTROL TRANSMAX DEX III Multi-Vehicle	35	7.2	175	-46°C	X	X
CASTROL	CASTROL TRANSMAX Z	38	7.2	170	-66°C		X
CHEVERON	TEXACO TEXAMATIC 7045E	34	7.4	194	-51°C		X
EXXONMOBIL	MOBIL Multi-Vehicle ATF	34	7.4	193	-54°C		X
EXXONMOBIL	MOBIL DELVAC SYNTHETIC ATF	39	7.3	168	-54°C		X
KUWAIT PETROLEUM	Q8 Auto 15	36	8.0	200	-48°C		X
PETRONAS	TUTELLA TRANSMISSION G/E	37	7.6	180	-48°C		X
SHELL	SHELL SPIRAX S4 ATF HDX	33	7.2	189	-48°C		X
SHELL	SHELL SPIRAX S6 ATF VM	34	7.4	185	-48°C		X
TOTAL	TOTAL FLUIDE XLD FE	34	7.1	181	-51°C		X
TOTAL	TOTAL FLUIDE G3	33	7.1	N/A	-45°C		X
TOTAL	TOTAL ELFMATIC G3	33	7.1	N/A	-45°C		X
TOTAL	TOTAL FLUIDE AT42	34	7.7	207	-51°C		X
VALVOLINE	HEAVY DUTY ATF PRO	36	7.2	172	-50°C		X
ATF-Oil With The Defined Specifications		<38	>7.0	>170	<-45°C		X

8.3 ADJUSTMENTS



Shutoff and lockout power before adjusting, servicing, maintaining, or clearing an obstruction from this machine. Refer to section 5.3 SHUTOFF & LOCKOUT POWER.

If work must be done inside the mixer, put a protective cover over the auger knives to avoid injury. The hopper and flighting may be slippery. Use caution when stepping on or standing inside the mixer.

8.3.1 Side Discharge Conveyor

To adjust tension of the chain, loosen the inner nut (Item 1) and either tighten or loosen the outer nut (Item 2) as needed. Count the number of turns you are adjusting so you can adjust the other end. Once you have proper tension, re-tighten the inner nut (Item 1) on both sides.

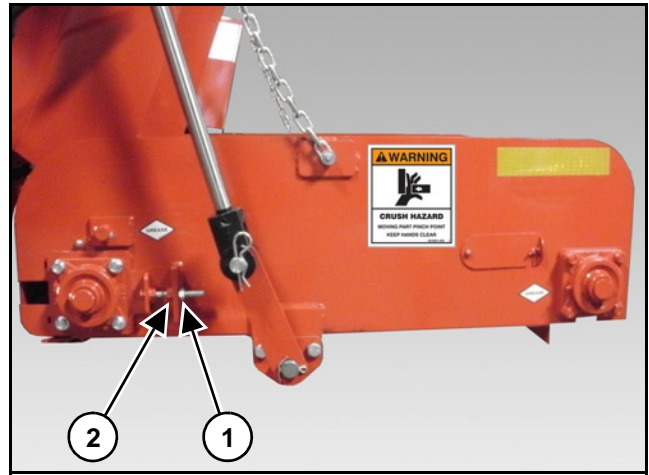

Figure 8.38 Side Discharge Conveyor

8.3.2 Belt Conveyor Tension

IMPORTANT

Check belt tension often. Belts can tighten with use.
Overtightening can cause damage to belt.

Front Conveyor:

Tension the belt (Item 1) so as the belt is flush with the bottom radius (Item 2) of conveyor side rails.

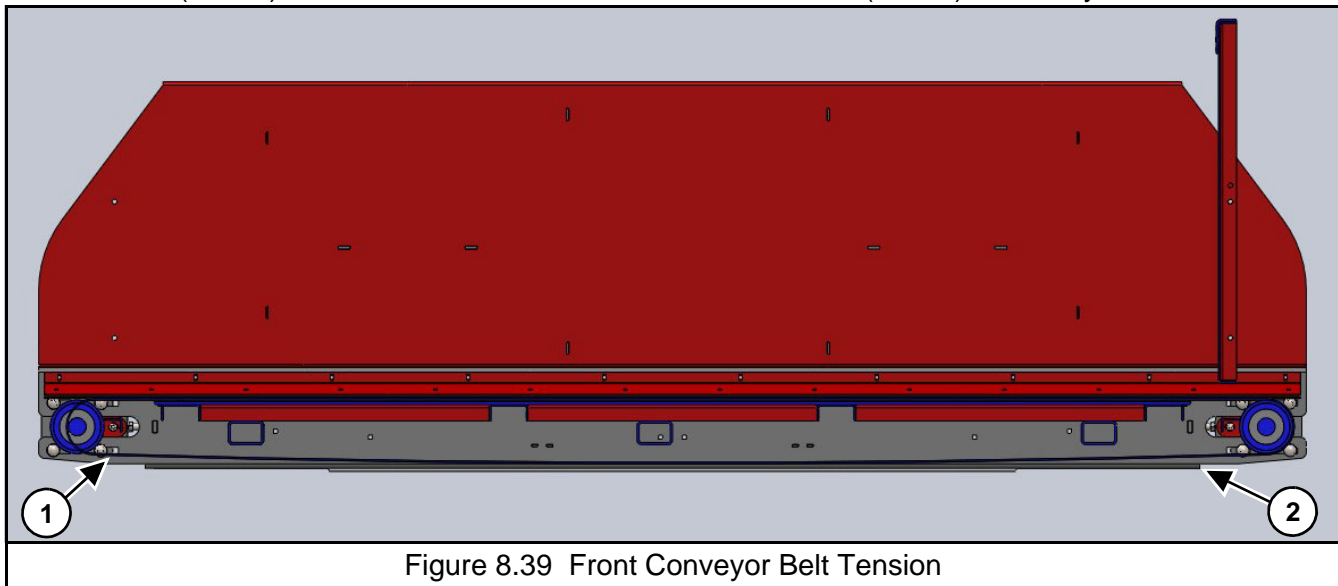

Figure 8.39 Front Conveyor Belt Tension

Incline/Side Discharge Conveyor:

Tension the belt (Item 3) so as the midpoint between both rollers sags $7/8$ " lower than at the rollers (Item 4).

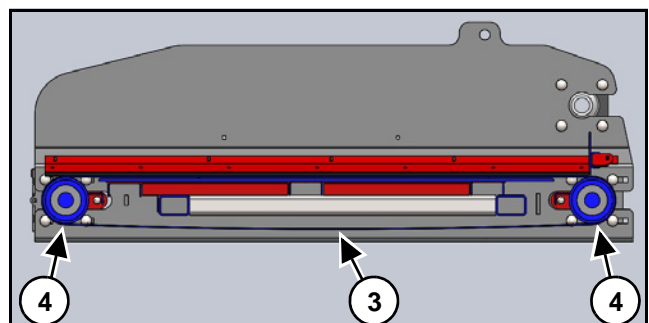

Figure 8.40 Incline/Side Conveyor Belt Tension

8.3.3 Tracking

NOTE: *The primary discharge side for the two motor flat conveyor is the side that is used for discharge the most.*

Step 1: Loosen the lock nuts (Item 1) holding the four bearings to the conveyor. Loosen the tightener nuts (Item 2) on all adjuster locations. Do not loosen the scraper bolts (Item 3).

Step 2: Locate the primary discharge side of the conveyor.

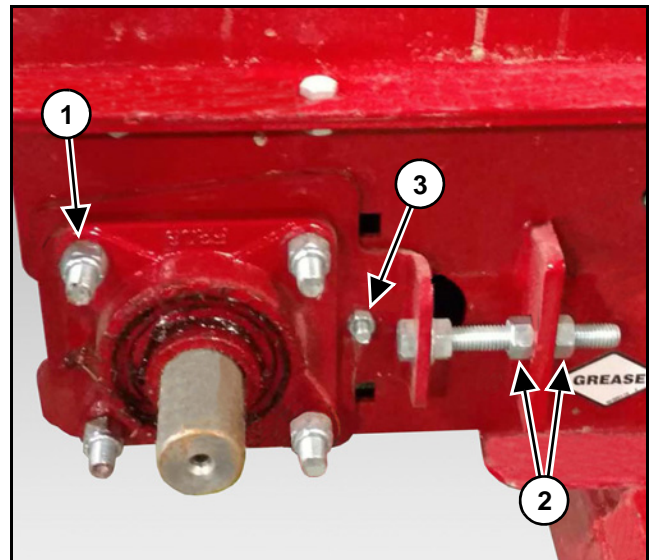

Figure 8.41 Conveyor Adjusters

Step 3: Set the primary side as follows:

Use the primary side adjusters to remove at least half of the belts slack. Measure, as shown below, until both sides of the drive pulley shaft (Item 4) are set at exactly the same from the end of the conveyor frame (Item 5).

Step 4: Once the primary drive pulley is set and square, tighten the lock nuts on both primary drive pulley bearings. Lock both adjusters on the primary drive pulley.

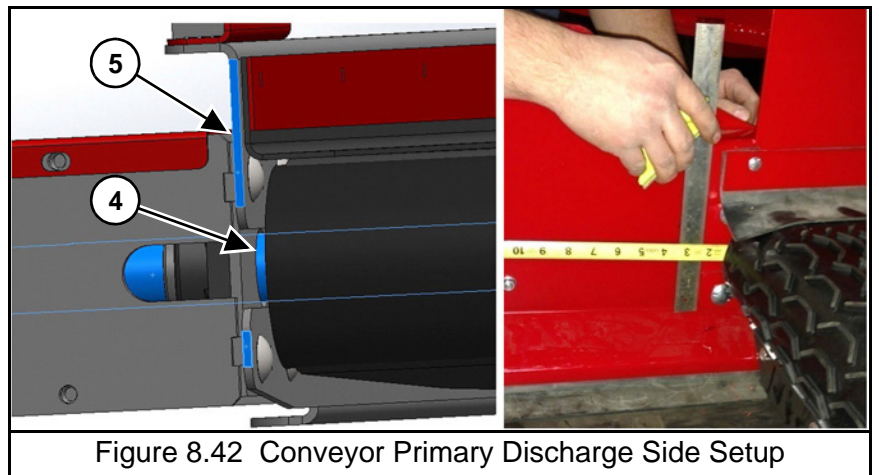

Figure 8.42 Conveyor Primary Discharge Side Setup

Step 5: With the primary discharge drive pulley set, move to the other side of the conveyor. Start to evenly tighten the belt by alternating sides on the non-primary discharge pulley adjusters. Tighten until the lowest hanging part of the belt is flush with the bottom of the conveyor frame. Once the belt is tight (Do not over tighten belt), measure the distance from the non-primary discharge shaft to the end of the conveyor frame, same as shown in Step 3. Do that for both shaft ends of the non-primary discharge pulley.

Step 6: Take the shortest measurement from either end and set both ends of the non-primary discharge pulley to the same measurement.

NOTE: *If you run out of adjustment on the non-primary side, repeat Step 3 and remove more slack from the belt using the primary side.*

Step 7: With the belt tightened as shown in section 8.3.2 Belt Conveyor Tension and the non-primary discharge pulley square with the conveyor frame, tighten the adjuster lock nuts for both non-primary discharge pulley bearings.

Step 8: Run the mixer conveyor for 2-3 minutes (both directions for front flat conveyors) at full RPM. If you notice the belt walking to the left or right while looking at the primary discharge end of the conveyor, stop the conveyor. Check your measurements to make sure both primary and non-primary discharge pulleys are square with the conveyor frame. If the conveyor pulleys are square but the belt continues to walk, use the images below to unlock and tighten the corresponding non-primary discharge pulley bearing adjuster (See Below). Continue to slightly adjust and run the conveyor until the belt stops walking.

NOTE: If the center *v* of the belt is completely out of the pulley groove, you may have to loosen both non-primary pulley adjusters to center the belt. Re-tighten to your measurement used in Step 6 before adjusting the conveyor as shown below.

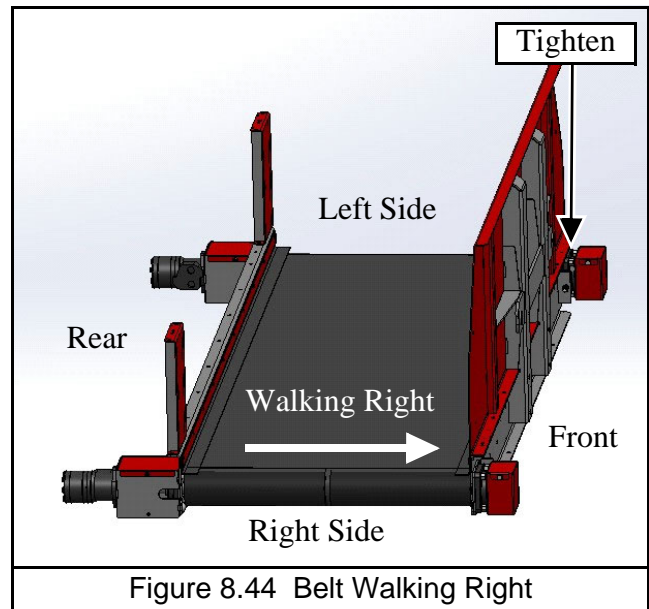
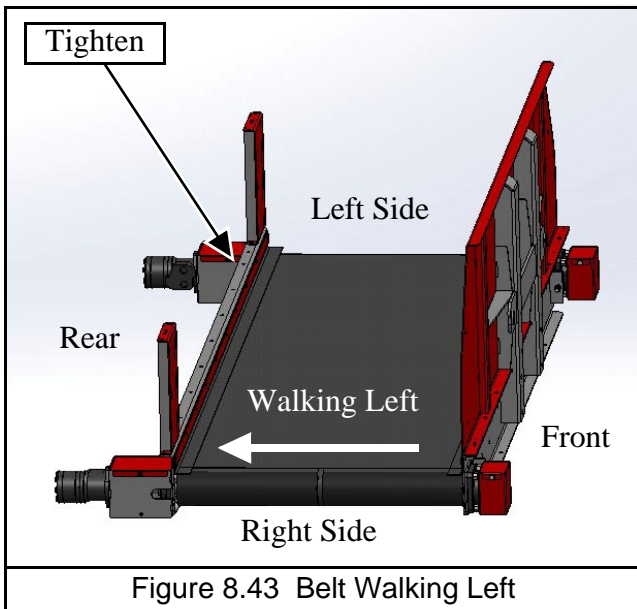

NOTE: Both images are viewed as if the conveyor is a right primary discharge.

Step 9: With the belt conveyor tracking properly, make sure all bearing bolts are tight and adjusters are locked.

Step 10: Watch the conveyor when discharging your feed ration to make sure the belt doesn't slip. If the belt is slipping, evenly tighten the non-primary discharge side. Run and check belt alignment. Repeat as necessary.

Step 11: Watch the conveyor when discharging your feed ration to make sure the belt doesn't slip. If the belt is slipping, evenly tighten the non-primary discharge side. Run and check belt alignment. Repeat as necessary.

NOTE: If you run out of adjustment on the non-primary side, repeat Step 3 and remove more slack from the belt using the primary side.

8.3.4 Front Discharge Conveyor - Chain

To adjust tension of the chain, loosen the inner nut (Item 1) and either tighten or loosen the outer nut (Item 2) as needed. Count the number of turns you are adjusting so you can adjust the other end. Once you have proper tension, re-tighten the inner nut (Item 1) on both sides.

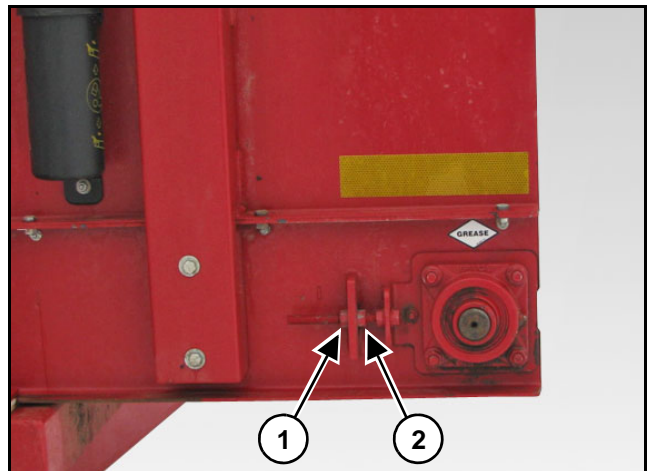

Figure 8.45 Chain Conveyor Adjusters

8.3.5 Auger Scraper Plate

Check the auger scraper monthly for proper clearance with the side panel. Locate the closest point along the augers rotation that the scraper comes to the baffles. Adjust the scraper to a 1/16" from the located closest point as shown in the image.

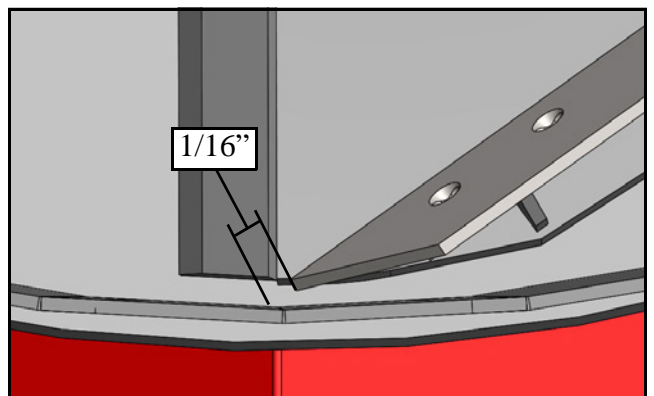

Figure 8.46 Auger Scraper Plate

8.3.6 Auger Timing

Auger timing is critical. Whenever disconnecting the PTO connecting the two planetaries, it is critical that the front leading edge be 225° from the rear leading edge when the rear leading edge is pointing to the front auger.

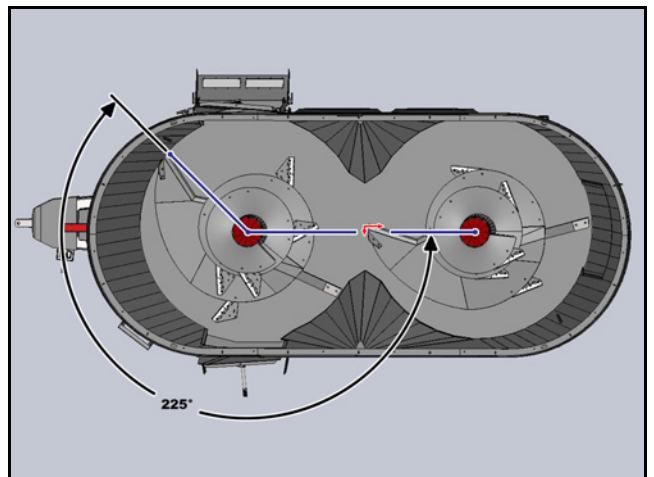

Figure 8.47 Auger Timing

8.3.7 Stop & Shift Driveline Alignment

Alignment of the driveline is very important. If the driveline is not properly aligned, a vibration noise could start occurring.

In order to properly align the drive shaft joints:

- Find the split in the yoke on the PTO (Item 1) and the split in the yoke on the Universal Joint (Item 2) before the 2-speed gearbox (Item 3) or planetary.
- These two splits should be installed so that they are in-line with each other as shown in the images below.
- You will notice the bolts holding the joints to the shaft are parallel.
- To adjust remove the bolt on the PTO yoke, adjust to align as shown, and re-tighten the bolt.
- Loosen the bolts that attach the bearing directly in front of the 2-speed gearbox (Item 4). With the bearing loose, rotate the shaft an entire revolution to ensure it doesn't bind. With the shaft rotating freely, tighten the bearing (Item 4) hardware.

NOTE: Mixer needs to be empty in order to rotate input shaft.

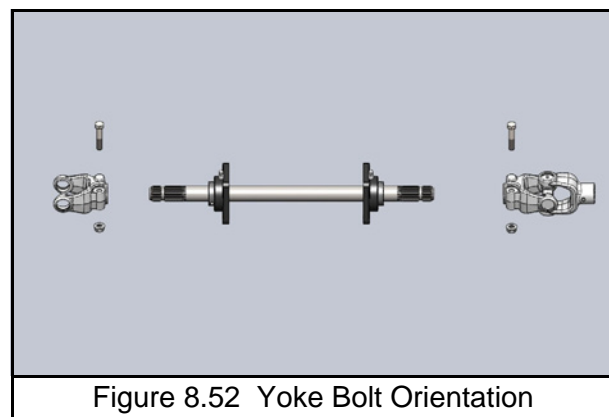
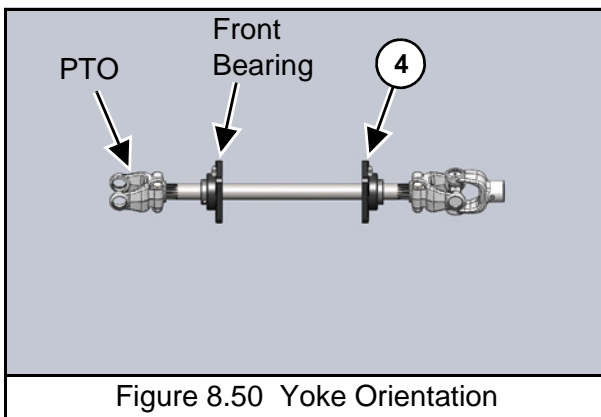
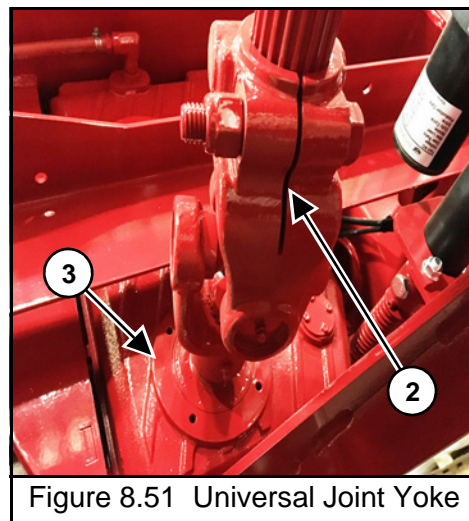
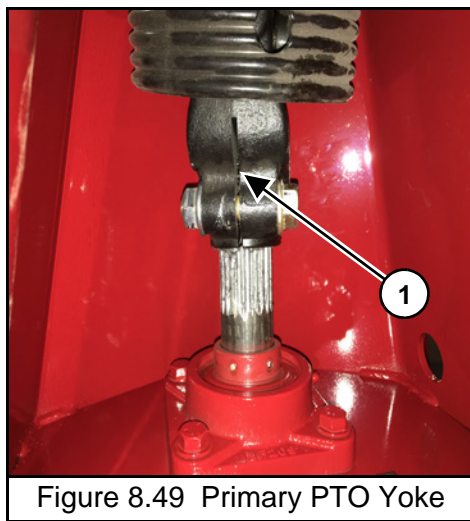
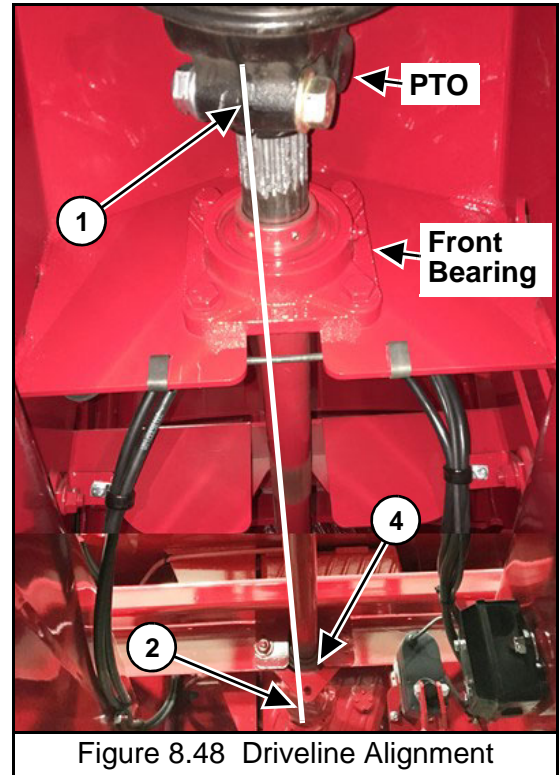

8.3.8 PTO Cutout Clutch Connection

The cutout clutch end of the PTO driveline must always be attached to the implement. The PTO driveline is equipped with a 1-3/4" x 20 spline on the implement half for attaching to the spreader. Remove the M17-hexagon bolt from the splined hub and slide the PTO onto the implement splined input shaft. Install the hexagon bolt (Item 1) through the hub being sure the bolt is falling into the groove on the splined shaft. Torque tight using a metric size M17 6-point socket and torque down to 75 ft. lbs. A M17 6-POINT METRIC SOCKET MUST BE USED AS ROUNDING OF HEXAGON BOLT AND INACCURACY OF TORQUE SETTINGS COULD OCCUR.

If removal of the M-17 hexagon bolt is necessary, use the same M-17 6-point socket and loosen bolt 1/2 turn. Insert a 1/4" drift punch in the hole on the opposite side of the hexagon bolt and tap to loosen the seated portion of the bolt from the splined hub. Loosen in 1/4 turn increments and tapping to loosen. After bolt seat has been released, remove the bolt. If bolt is not unseated, damage to the hexagon bolt will occur.

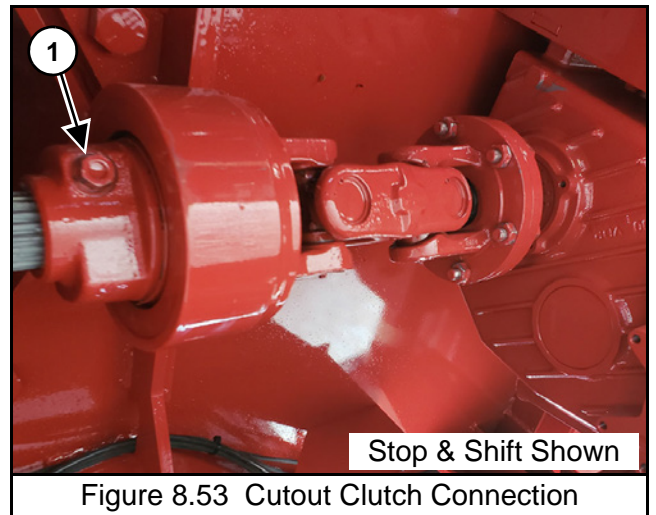

8.3.9 Knives

Knives are designed and intended for processing and mixing rations that include long stem forages.

NOTE: Some rations may require adding or removing knives, or changing knife position to obtain the desired result.

8.3.9.1 Knife Removal

Individual knives may be removed from the auger if the ration does not include hay or includes very small amounts of small square bale hay or tub ground hay. Removing knives will decrease the aggressive cutting action on the stem length of the ration and may also reduce horsepower requirements.

8.3.9.2 Adding Knives

If the hay in your ration is not being processed enough or fast enough extra knives may be ordered through your dealer. Adding extra knives will help break down and process materials faster, but may increase the horsepower required to process and mix.

8.3.9.3 Knife Placement

The placement of knives towards the bottom of the auger will process the forage faster and make the stem length shorter but may require more horsepower. Placement of knives higher on the auger will assist in breaking up bales faster after initial loading.

8.3.9.4 Knife Position

“Out” Position

When the knives are in the “out” position they tend to move the long stem hay and lighter bulky materials best in the early stages of processing and mixing. This setting may result in feed spillage in certain materials. Knives placed in this setting are very aggressive in processing feed and will also cause an increase in horsepower requirement.

“In” Position

When the knives are in the “in” position they will slow down the long stem hay and lighter bulky materials in the early stages of processing and mixing. Less spillage will occur due to clearance between the knives. This setting is more desirable for heavy rations with long run time and where over processing can occur. Knives placed in this position are less aggressive in processing feed and will reduce the horsepower requirement.

8.3.9.5 Replacing Damaged or Worn Knives

When knives become worn and rounded on the leading edge their efficiency is greatly reduced. This results in longer processing times and increased horsepower requirements. Refer to your parts manual and contact your Meyer MFG dealer for replacement part ordering.

8.3.10 Brake Adjustment (If Equipped)

Properly support wheel end to adjust the brakes with the tire assembly removed.

Excessive actuator travel (over one inch) is a sign that the brakes need to be adjusted. Jack wheel/tire off of the ground and rotate tire in the forward direction. The brake adjustment nut is located through a slot at the bottom of the backing plate. Insert brake tool or screwdriver into slotted hole with handle up and bit against the adjusting wheel, pull down on handle and rotate drum in forward direction while tightening. When you can no longer rotate drum in the forward direction, then loosen the large nut on the back side of the brake cluster, located at the 12 o'clock position, one turn, do not take nut completely off, just loosen to allow anchor pin to realign. Take dead blow hammer and tap on brake drum several times around the perimeter, now re-tighten the large anchor pin nut. Back off adjuster twenty clicks (notches) for two-wheel brake systems and fifteen clicks (notches) for four wheel brake systems, and back off shoe adjuster 10-15 clicks. If there is one spot where the wheel drags just slightly, this is acceptable. As soon as the brake linings are burnished (this requires several braking stops) the brakes will then be set correctly.

8.3.11 Wheel Bearing Preload

1. Chock all four wheels or hitch to tractor with engine off, key removed and parking brake set. Jack empty mixer off ground and support with adequate jack stands.
2. Push back and forth on each wheel assembly. If play is detected, bearings need adjusting.
3. If adjusting bearings, it is suggested the bearings be repacked as described previously.
4. Remove hub cap and remove cotter pin from spindle nut.
5. Tighten spindle nut to remove all play. It should be snug and slight drag can be felt while rotating the wheel.
6. If the cotter pin hole in the spindle does not line up with the notch in spindle nut, back off the spindle nut only enough to line up. Reinstall cotter pin. If cotter pin is damaged, replace it.
7. Replace hub cap and lower wheel to the ground.

8.4 FASTENER TORQUE SPECIFICATIONS



Shutoff and lockout power before adjusting, servicing, maintaining, or clearing an obstruction from this machine. Refer to section 5.3 SHUTOFF & LOCKOUT POWER.

After an initial break in period approximately four months and periodically thereafter, ALL bolts and nuts should be checked to ensure that recommended torque values are being maintained.

8.4.1 General Torque Specifications



DO NOT use these values if a different torque value or tightening procedure is given for a specific application. Torque values listed are for general use only and include a + or - 10% variance. Check tightness of fasteners periodically. DO NOT use air powered wrenches.

Head Marking	Grade and Material	Nominal Size Range (inches)
 No Markings	Grade 2 Low or medium carbon steel	1/4" thru 3/4" Over 3/4" thru 1-1/2"
 3 Radial Lines	Grade 5 Medium carbon steel, quenched and tempered	1/4" thru 1" Over 1" thru 1-1/2"
 6 Radial Lines	Grade 8 Medium carbon alloy steel, quenched and tempered	1/4" thru 1-1/2"
 A325	Grade A325 Carbon or Alloy Steel with or without Boron	1/2" thru 1-1/2"
Stainless markings vary. Most stainless is non-magnetic	18-8 Stainless Steel alloy with 17-19% Chromium and 8-13% Nickel	All Sizes thru 1"

Figure 8.55 SAE Bolt Grade

Head Marking	Class and Material	Nominal Size Range (mm)
 8.8	Class 8.8 Medium carbon steel, quenched and tempered	All Sizes below 16mm 16mm - 72mm
 10.9	Class 10.9 Alloy steel, quenched and tempered	5mm - 100mm
 12.9	Class 12.9 Alloy steel, quenched and tempered	1.6mm - 100mm
Stainless markings vary. Most stainless is non-magnetic. Usually stamped A-2.	A-2 Stainless Steel alloy with 17- 19% chromium and 8-13% nickel	All Sizes thru 20mm

Figure 8.54 Metric Bolt Grade

SAE				
	Grade 5, 5.1 & 5.2		Grade 8 & 8.2	
Size (inches)	Lubricated (lb-ft)	Dry (lb-ft)	Lubricated (lb-ft)	Dry (lb-ft)
1/4	7	9	10	12.5
5/16	15	18	21	26
3/8	26	33	36	46
7/16	41	52	58	75
1/2	63	80	90	115
9/16	90	115	130	160
5/8	125	160	160	225
3/4	225	280	310	400
7/8	360	450	500	650
1	540	675	750	975
1-1/8	675	850	1075	1350
1-1/4	950	1200	1500	1950
1-3/8	1250	1550	2000	2550
1-1/2	1650	2100	2650	3350

METRIC								
	Class 4.8		Class 8.8 & 9.8		Class 10.9		Class 12.9	
Size (mm)	Lubricated (lb-ft)	Dry (lb-ft)	Lubricated (lb-ft)	Dry (lb-ft)	Lubricated (lb-ft)	Dry (lb-ft)	Lubricated (lb-ft)	Dry (lb-ft)
M6	3.5	4.5	6.5	8.5	9.5	12	11.5	14.5
M8	8.5	11	16	20	24	30	28	35
M10	17	21	32	40	47	60	55	70
M12	29	37	55	70	80	105	95	120
M14	47	60	88	110	130	165	150	109
M16	73	92	140	175	200	225	240	300
M18	100	125	195	250	275	350	325	410
M20	140	180	275	350	400	500	460	580
M22	190	250	375	475	540	675	625	800
M24	250	310	475	600	675	850	800	1000
M27	360	450	700	875	1000	1250	1150	1500
M30	490	625	950	1200	1350	1700	1600	2000
M33	675	850	1300	1650	1850	2350	2150	2750
M36	850	1075	1650	2100	2350	3000	2750	3500

8.4.2 Wheel Torque

BOLT/STUD SIZE	SOCKET SIZE	PRESS FORMED WHEEL CENTER	BOLT TYPE	HEAVY DUTY WHEEL CENTER
3/4"	1-1/8" / 1-1/2"	N/A	Flange Nut	378 lb-ft
5/8"	15/16" / 1-1/16"	100 lb-ft	Bevel or Flange Nut	160 lb-ft

8.4.3 Hub Torque

1. Torque the spindle nut while rotating the hub to seat the bearings using the Seat Bearings torque value for your specific hub listed in the table below.
2. Loosen spindle nut.
3. Re-torque the spindle nut to the Final Torque.
4. Install cotter pin. If the nut isn't aligned with the cotter pin hole, back the nut off to closest position that does. **Do Not** back the nut off more than 30° from Final Torque position.

MEYER PART #	MODELS	SEAT BEARINGS	FINAL TORQUE
75-0219	815/1015	75 lb-ft	45 lb-ft
75-0217	1215	105	65
75-0218	1215 (Brake Trailer)		

8.5 ELECTRICAL

8.5.1 Power Shift Remote Control Programming

1. Apply a temporary 12 Volt positive (Key 1) and negative (Key 2) source to the receiver.
2. Locate the push button labeled "PROGRAM" on the receiver. Press and hold this button until the red LED next to the program button illuminates (approximately 3 seconds). The receiver is now in the remote program mode. Release the button. At this point all previously programmed remotes are erased from the receiver's memory.

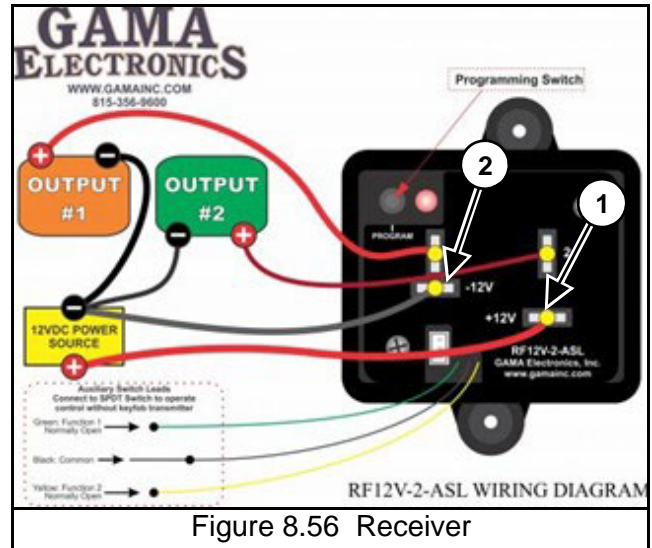

3. **Single Remote:** Press and release either button on the remote once and verify that the red program LED extinguishes and blinks once.

- Multiple Remotes:** For the first remote being programmed press and release either button once, then once on the second remote, once on the third remote, once on the fourth remote etc. The receiver will not respond to remotes that have been previously programmed. The first remote that is programmed determines the receiver's relay operating mode.
4. The receiver will return to normal mode if no remote buttons are pressed for 5-seconds. The red LED on the receiver will blink rapidly, then extinguish. The receiver is now in the normal mode of operation. Test remote by pressing either button. The red program LED on the receiver should stay on until the button on the remote is released.
5. This completes the programming instructions. The receiver will retain its programming even when power is removed.
6. Remove the temporary 12 Volt positive (Key 1) and negative (Key 2) source to the receiver.



8.5.1.1 Remote Troubleshooting

If your RF remote control system does not work out of the box, stops working or functions intermittently please take the following steps to resolve common issues. Please note that you must be 2-3 feet away from the receiver when operating the transmitter. Operating within 2-3 feet may result in no operation or intermittent operation.

1. Recharge your remote.
 - The remote can activate during shipping and drain the battery.
 - The remote can be charged using a micro USB cable and any standard USB outlet or charger. Plug the micro USB into the connector located on the bottom of the remote.

NOTE: When the transmitter is plugged into a USB outlet/charger the LED backlights will slowly fade on and then fade off while the unit is charging. Once the transmitter has reached a full charge, the LEDs will extinguish and remain off.

2. Check the voltage supply at the receiver.
 - The receiver is designed to function at 10VDC-15VDC. Voltage on the (+) and (-) terminals on the control should be within this range.
3. Reprogram the remote.
 - If the system is non-functional, try to reprogram the remote. The program may not have taken during the programming process, or the program button may have been pressed. If the program button is pressed the memory of the remote(s) programed to the receiver are erased.
4. Listen and look for functionality on the receiver.
 - The LED that is used for programming the system will illuminate when the receiver is activated. You will also hear a “click” when the internal relays engage. If you can see the LED illuminate and you hear the relay “click” the issue is most likely in the wiring or device being controlled.

8.5.2 Digital Scale Indicator

Refer to scale indicator (Item 1) manufacturer’s operators manual for maintenance.

NOTE: Some scale drift may occur after the scale is turned on but should level out within 10 to 15 minutes. Temperature changes may also cause some drifting.

JUNCTION BOX WIRING						
	FUNCTION	WEIGH BAR WIRING			MONITOR WIRING	
		DIGISTAR	WEIGH-TRONIX	DYNAMICA GENERALE	STANDARD	WEIGH-TRONIX*
1	+SIG	WHITE	WHITE	GREEN	WHITE	WHITE
2	-SIG	GREEN	RED	WHITE	GREEN	RED
3	+EX	RED	GREEN	RED	RED	GREEN
4	-EX	BLACK	BLACK	BLACK	BLACK	BLACK
5	SHIELD	TRANSP	ORANGE	BLUE	TRANSP	TRANSP

*WEIGH-TRONIX MONITOR WITH WEIGH-TRONIX WEIGH BARS ONLY 46-0001-199 2

Figure 8.58 Weigh Bar Wiring Diagram

Scale Set Up Numbers

Digistar Monitors	
SET UP #	CALIBRATION #
146060	36753

Weigh-Tronix Monitors	
CONFIGURE #	CUSTOM #
98300	35910

8.6 BRAKES (OPTIONAL)



WARNING

Any corrosive materials (saltwater, fertilizers) are destructive to metals. To properly maintain the life of the brake system flushing with a high pressure water hose is recommended. After washing be sure to grease actuator bearings (slides) and oil all moving parts. At the end of season it is recommended that the brake drums be removed and cleaned inside. Flush wheel bearings being careful not to contaminate the brake system with lube. Readjust the brakes.

IMPORTANT

Before using any equipment equipped with brakes the operation of the brakes should be checked. Brake linings should be replaced before the rivets or support plates come in contact with the wheel drum. Perform all necessary maintenance before using equipment.

Check and test the brakes before intensive use and every three months thereafter. Check the brake wear and the clearance between the brake linings and the drum visually. It is probable that the linings are worn when the brake travel has increased significantly. If the linings are worn to the minimum thickness, replace with new.

8.6.1 Brake Bleeding

Before bleeding brakes, fill the system with DOT 3 hydraulic brake fluid. Using a vacuum type brake bleeder (this type of brake bleeder is available at your local automotive store) follow manufacturer's directions for bleeding.

Install bleeder hose on first wheel cylinder to be bled, if tandem bleed rear axles first. Have loose end of hose submerged in a glass container of brake fluid to observe bubbling. By working the manual hand pump, you will draw the air out of the brake lines filling it with fluid.

By loosening the bleeder screw located in the wheel cylinder one turn, the system is open to the atmosphere through the passage drilled in the screw. When the bubbling stops in the glass container close the bleeder screw securely. Follow the same procedure at each wheel cylinder being sure to maintain the master cylinder fluid level at least one half full of brake fluid. After all wheels are bled fill the master cylinder to 3/8" below the full level.

8.7 WHEELS AND TIRES

8.7.1 Wheel Installation



These instructions are not complete. Read and follow all procedures in user's guide to wheels and rims by "The Maintenance Council" #T0410. If you have questions call Walther Eng. & Mfg. company inc. (937) 743-8125.

- Clean adjoining surfaces.
- Start nuts to bring wheel and brake drum (If Equipped) flush to hub mounting surface.
- Avoid brake drum (If Equipped) and/or wheel binding on hub.
- Install remaining wheel nuts. Torque to 50 ft-lbs, then re-torque to required full torque (See 8.4.2 Wheel Torque).
- Re-torque wheel nuts after 50-100 miles.
- Check wheel nut torque every 10,000 miles and re-torque as necessary.

8.7.2 Tire Inflation

TIRE SIZE	PSI
385/65R x 22.5	100
245/70R x 19.5	100
380/60R x 16.5	73
380/55R x 16.5	73
435/50 x 19.5	100
12.5L-15	52

If tires are to operate for any length of time on roads or other hard surfaces and the draft load is not great, it is advisable to increase the pressure in the tire to the maximum recommendation in order to reduce the movement of the tread bars that causes excessive wiping action.

Inflation pressures should be checked at least every week. Recommended inflation pressures based on total load on tires should be used. For accurate inflation use a special low-pressure gauge with one-pound gradations. Gauges should be checked occasionally for accuracy. Always use sealing valve caps to prevent loss of air.

8.7.3 Implement Tires

Agricultural tires are designed to carry a specified load at a specified inflation pressure when mounted on a specified width rim. When these conditions are met, the deflection of the tire carcass is in the optimum range and maximum tire performance can be expected. If this combination of design factors is altered for any reason, tire performance will be reduced.

Tire Overload or Under Inflation

Tire overload or under inflation have the same effect of over-deflecting the tire. Under such conditions the tread on the tire will wear rapidly and unevenly, particularly in the shoulder area. Radial cracking in the upper sidewall area will be a problem. With under inflated drive tires in high torque applications sidewall buckles will develop leading to carcass breaks in the sidewall. While an under inflated drive tire may pull better in some soil conditions, this is not generally true and not worth the high risk of tire damage that such an operation invites.

Over Inflation

Over inflation results in an under-deflected tire carcass. The tread is more rounded, concentrates tread wear at the centerline area. Traction is reduced in high torque service because ground contact of the tread shoulder area is reduced and the harder carcass, with reduced flexing characteristics, does not work as efficiently. The tightly stretched overinflated carcass is more subject to weather checking and impact break damage.

Pressure Adjustments Required - Slow Speed Operation

Higher tire loads are approved for intermittent service operations at reduced speed. Under such conditions inflation pressure must be increased to reduce tire deflection and assure full tire service life. See 8.7.2 Tire Inflation for proper inflation.

Use of Proper Width Rims

If tires are mounted on rims of incorrect width, the following conditions can result:

- Use of a wider rim results in flattening of the tread face. This feature may improve traction in loose soil conditions. In hard soils, however, the flatter tread penetrates less effectively and tractive effort is reduced. Additional stresses concentrated in the shoulder area tend to increase the rate of shoulder tread wear. By spacing the tire beads farther apart the sidewalls are forced to flex in an area lower than normal and this can result in circumferential carcass breaks and/or separation.
- Use of a narrower rim brings potential mounting problems because the rim shield or flange cover molded into most drive tire designs tends to interfere with the seating of the tire beads on a narrow rim. Once mounted on a narrow rim, the tire shield applies undue pressure on the rim flange, with possible tire sidewall separation or premature rim failure at the heel radius. On a narrow rim the tread of the tire is rounded. As with the over-inflated tire tread wear will be concentrated in the center area of the tread and traction in the field will be reduced.

Roading Of Farm Implement Tires

- Tractor tires operate most of the time in field conditions where the lugs can penetrate the soil, and where all portions of the tread make contact with the ground. In operating on hard roads with low inflation pressure there is an undesirable distortion of the tire during which the tread bars squirm excessively while going under and coming out from under the load. On highly abrasive or hard surfaces, this action wipes off the rubber of the tread bars or lugs and wears them down prematurely and irregularly.
- Farm tractor and implement tires are designed for low-speed operations not exceeding 25 miles per hour. If tractors or implements are towed at high speeds on the highway high temperatures may develop under the tread bars and weaken the rubber material and cord fabric. There may be no visible evidence of damage at the time. Later a premature failure occurs which experience shows was started by the overheated condition that developed when the unit was towed at a high speed.

Care And Storage Of Tractor And Implement Tires

- All tires should be stored indoors in a cool, dark, dry area free from drafts. Both heat and light are sources of oxidation on the tire surfaces - a result of which is crazing and weather checking. Tires should never be stored on oily floors or otherwise in contact with solvents, oil or grease. Further, tires should not be stored in the same area with volatile solvents. Such solvents are readily absorbed by rubber and will damage and weaken it.
- Tires should be stored away from electric motors, generators, arc welders, etc. since these are active sources of ozone. Ozone attacks rubber - to cause crazing and weather checking.
- Unmounted tires should be stored vertically on tread. If stored for an extended period, tires should be rotated periodically to reduce stress concentrations in the area of ground contact. Tires should not be stored flat and “stove piped” as they will become squashed and distorted, making mounting on the rim difficult - particularly for tubeless tires.
- Inflated tires mounted on rims should be stored under conditions noted above, with inflation pressure reduced to 10 PSI.

8.8 STORING THE IMPLEMENT

LOCKOUT / TAGOUT the machine / mixer. (See 5.3 SHUTOFF & LOCKOUT POWER)

Extended Storage

Sometimes it may be necessary to store your Meyer mixer for an extended period of time. Below is a list of items to perform before storage.

- Fully empty the material from the mixer. (See 7.6 UNLOADING)
- Thoroughly clean the mixer inside and outside.
- Remove all material build-up.
- Lubricate the equipment. (See 8.2 LUBRICATION)
- Inspect all mixer components for wear or damage. Repair and replace components as necessary.
- Make appropriate adjustments to equipment. (See 8.3 ADJUSTMENTS)
- Place hydraulic hoses and 7-pin connector in the storage brackets (if equipped).
- Inspect the hitch and all welds on the equipment for wear and damage.
- Check for loose hardware, missing guards, or damaged parts.
- Check for damaged or missing safety signs (decals). Replace if necessary.
- Touch up all paint nicks and scratches to prevent rusting.
- Place the equipment in a dry protected shelter.
- Place the equipment flat on the ground.

8.9 RETURN THE IMPLEMENT TO SERVICE

After the Meyer mixer has been in storage, it is necessary to follow a list of items to return the equipment to service.

- Be sure all shields and guards are in place.
- Lubricate the equipment.
- Check tire pressure and that the lug nuts are tight.
- Connect to a tractor and operate equipment; verify all functions operate correctly.
- Check for leaks. Repair as needed.



9.0 REPAIR PARTS

WARNING

Before servicing this equipment, ensure that all personnel, including family members are familiar with the equipment and the safety hazards that are present, along with the safety practices that should be observed while working in this equipment.

CAUTION

Inspect the axles, o-beams, spindles, tires, hitches and all safety shielding, safety signs and safety lighting regularly. These parts if not watched closely, could pose potential injury or death. If any part is found in need of repair, follow the SHUTOFF & LOCKOUT POWER recommendations and have qualified personnel repair immediately.

CAUTION

Shutoff and lockout power before adjusting, servicing, maintaining, or clearing an obstruction from this machine. Refer to section 5.3 SHUTOFF & LOCKOUT POWER.

IMPORTANT

It is important that everyone who works on this equipment is properly trained to help ensure that they are familiar with this procedure and that they follow the steps outlined above. This manual will remind you when to SHUTOFF & LOCKOUT POWER.

At times, parts on this implement will become worn or damaged. Performing repairs on this implement can pose a risk of injury including death. To reduce risk, the party that will be doing the repair should be very knowledgeable of the implement and the equipment that they will be using to do the repair.

- Review the repair so that a plan can be put together and the proper equipment can be used to repair this implement safely and correctly.
- Personal safety equipment may include items such as safety glasses, protective footwear, hearing protection, gloves, fire retardant clothes, etc.

WARNING

Crushing Hazard:
Do Not work under suspended or blocked parts



- The use of hoists and/or supports may be needed to handle heavy components.
- If the implement is being repaired in the field, make sure the parking brake of the tractor is engaged, the implement is on solid and level ground.
- Welding and torching should be done by properly trained individuals who have proven their skills.

IMPORTANT

Call the factory for any additional details you may need to perform the repair. Some parts may come with instruction sheets to assist in the repair. Instruction sheets may be provided with the parts order. Otherwise, if available, instruction sheets can be e-mailed or faxed for your convenience. Call Meyer Manufacturing Corporation toll free at 1-800-325-9103 or email parts@meyermfg.com.

NOTE: Be environmentally friendly and dispose of any waste materials properly. Recycle when appropriate.



STOP & SHIFT LIGHTS

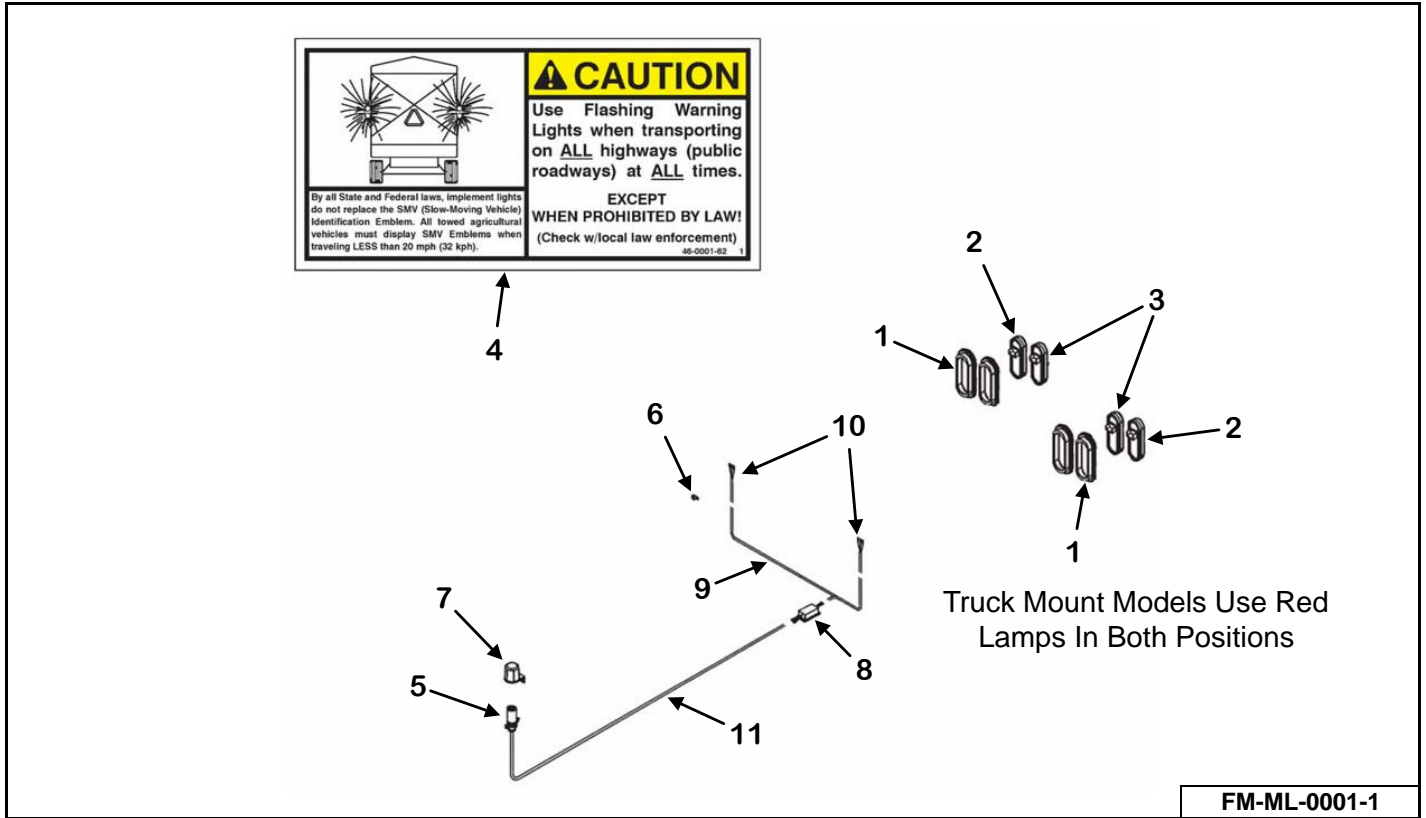

KEY	PART NUMBER	QTY	DESCRIPTION	MIXER MODEL
1	56-0082	4	6" Oval Grommet	815 - 1215
2	56-0081	2/0	6" Oval Amber LED Light	815 - 1215
3	56-0115	2/4	6" Oval Red LED Light	815 - 1215
4	46-0001-62	1	Caution Tail Light Decal	815 - 1215
5	56-0005-2	1	7-Contact Plug End Only	815 - 1215
6	56-0008	2	Harness Frame Clip	815 - 1215
7	56-0009	1	7-Way "Stor-A-Way" Plug Holder	815 - 1215
8	56-0084	1	LED Ag Enhancer Module (Trailer Mounts Only)	815 - 1215
9	56-0130-1	1	Y-Harness Less Light Plug Leads	815 - 1215
10	56-0130-2	2	Right/Left Light Pigtail Lead	815 - 1215
11	56-0209	1	Front Discharge 28' LED Light 6-Pin & 7-Pin Connector	815 - 1215
	56-0210	1	Side Discharge 24.5' LED Light 6-Pin & 7-Pin Connector	815 - 1215

POWER SHIFT LIGHTS

(SN 21VM1215205, 21VM1215206 & 22VM1215201)

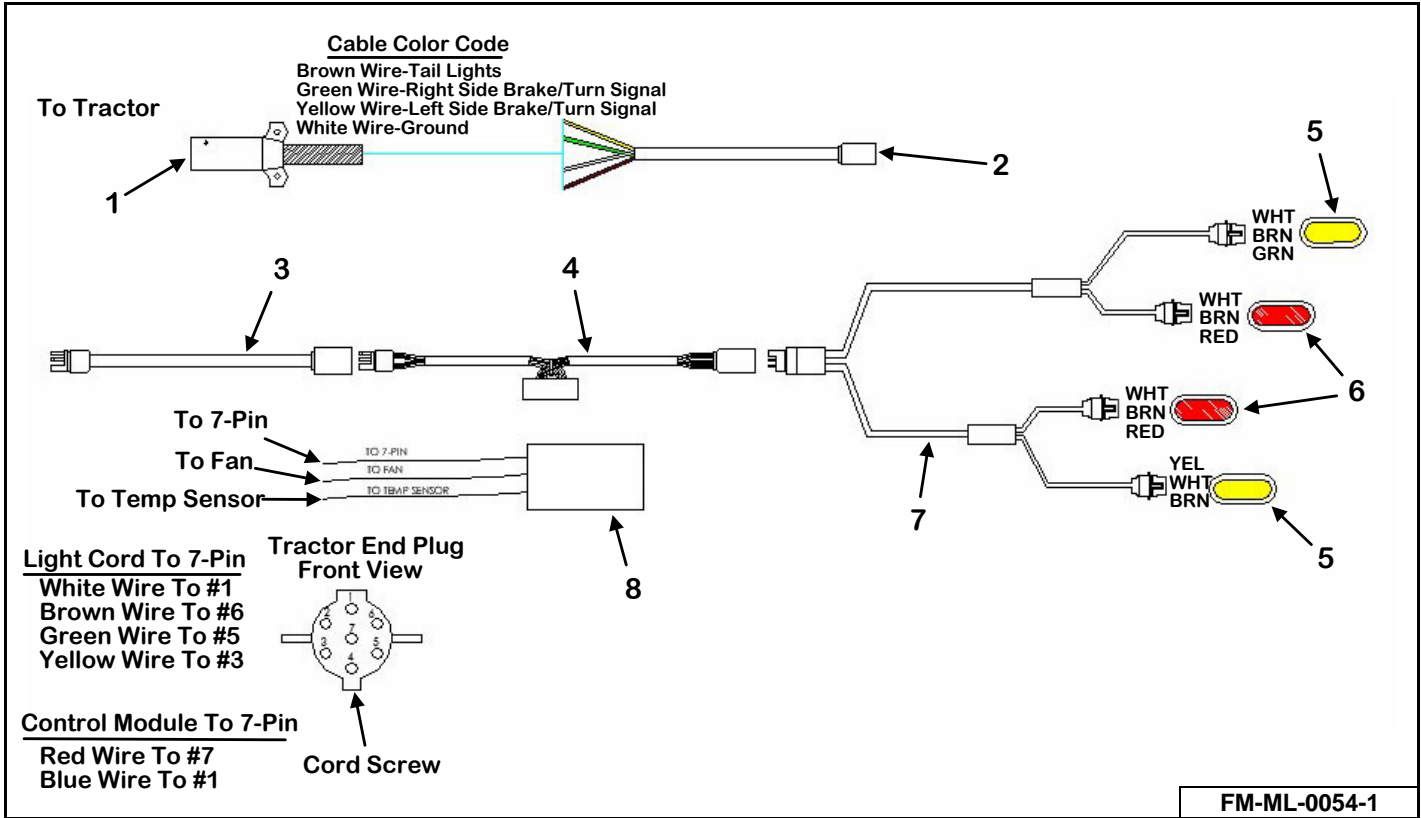

POWER SHIFT LIGHTS

(SN 22VM1215203 & LATER)

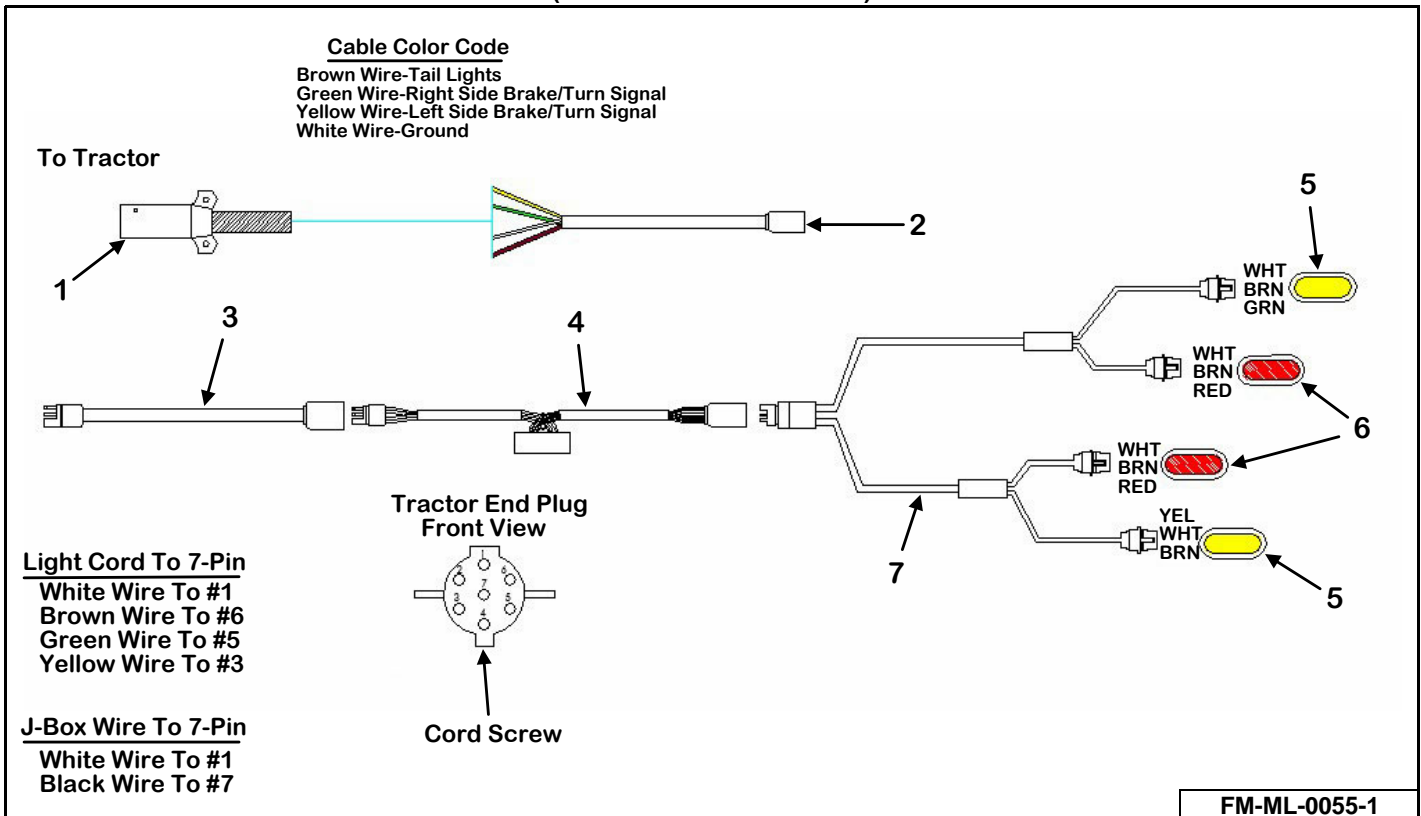

KEY	PART NUMBER	QTY	DESCRIPTION	MIXER MODEL
1	56-0005-4	1	7-Way Plug With Spring	815 - 1215
2	56-0306	1	Maxi-Seal Front Harness to 7-Pin	815 - 1215
3	56-0307	1	198" Maxi-Seal Harness Power Extension (Side Discharge)	815 - 1215
	56-0298	1	222" Maxi-Seal Harness Power Extension (Front Discharge)	815 - 1215
4	56-0284	1	Maxi-Seal Ag Module	815 - 1215
5	56-0081-AMP	2	6-1/2" Amber Clearance Light	815 - 1215
	56-0082	2	6-1/2" Oval Grommet	815 - 1215
6	56-0115-AMP	2	6-1/2" Red Clearance Light	815 - 1215
	56-0082	2	6-1/2" Oval Grommet	815 - 1215
7	56-0310	1	Maxi-Seal Rear Harness	815 - 1215
8	155-OC-TT07-1-1	1	Temperature Control Kit	815 - 1215

WEIGH BAR WIRING DIAGRAM

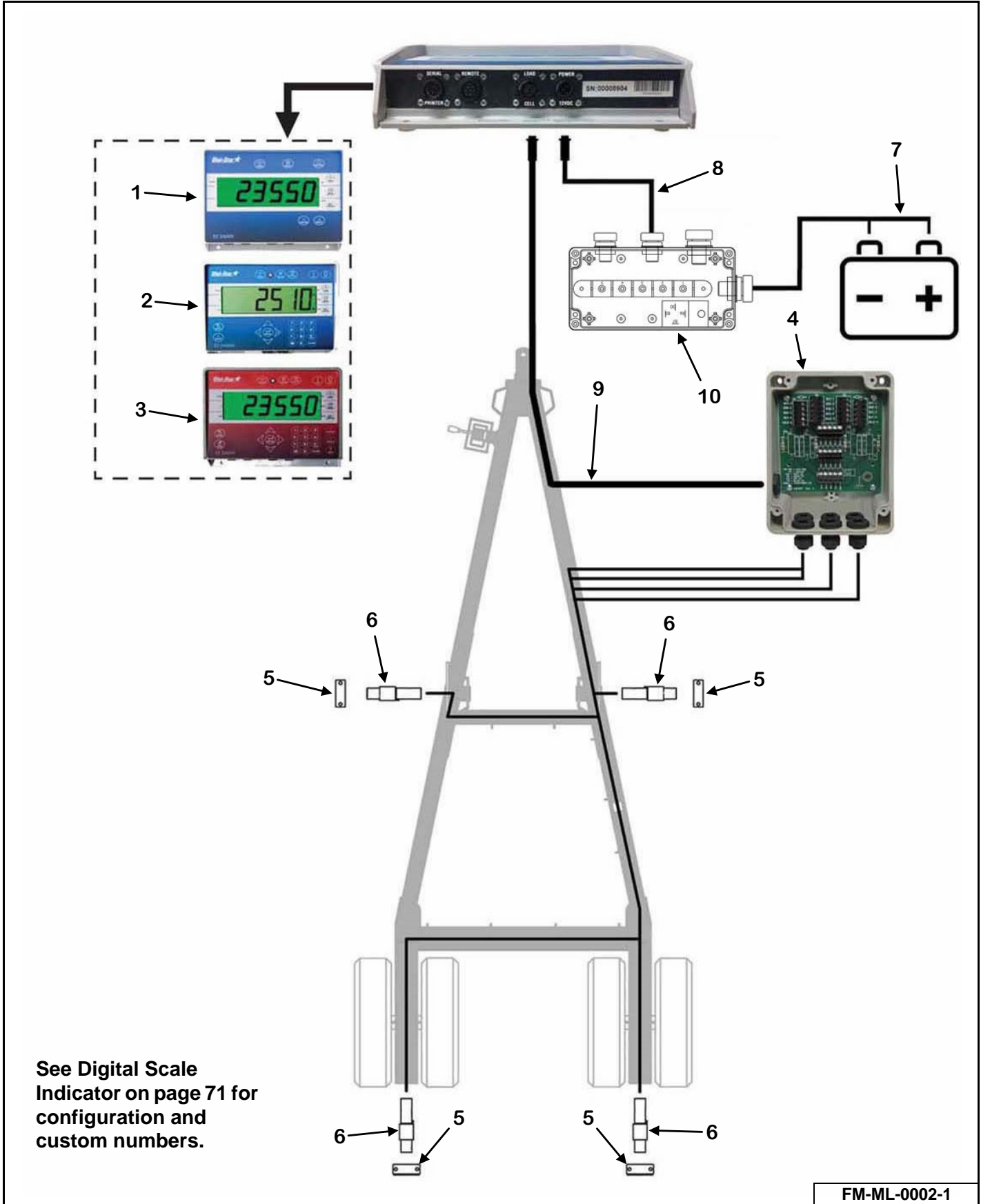

See Digital Scale Indicator on page 71 for configuration and custom numbers.

FM-ML-0002-1

KEY	PART NUMBER	QTY	DESCRIPTION	MIXER MODEL
1	58-0002-1057170-01	1	EZ2805 Scale Indicator Monitor	815 - 1215
	58-0002-281047	1	EZ2810 Scale Indicator Monitor	815 - 1215
2	58-0002-341047	1	EZ3410 Scale Indicator Monitor	815 - 1215
3	58-0002-361023	1	EZ3610 Scale Indicator Monitor	815 - 1215
4	58-0020	1	6 Point Mobil J-Box	815 - 1215
	58-0008	1	6 Point Mobil J-Box With Monitor Cable	815 - 1215
5	M9-1-8-0001	4	DB Bar Mount	815 - 1215
	881-7510-2.5Z	8	3/4"-10 x 2-1/2" Bolt	815 - 1215
6	58-0034-WT	4	2.875" x 14" Load Cell	815 - 1215
7	See Page 84	1	Stop & Shift Power Cord Assembly	815 - 1215
	See Page 86	1	Power Shift Power Cord Assembly	815 - 1215
8	58-0035-10	1	10' Power Cord	815 - 1215
9	58-0029	1	Junction Box To Monitor Cable 30'	815 - 1215
10	See Page 84	1	7-Terminal Enclosure Mixer (Stop & Shift Models)	815 - 1215
	See Page 86	1	Junction Box Assembly (Power Shift Models)	815 - 1215
NS	58-0002-410002	1	Pack RPM Sensor (No Extension Cable)	815 - 1215
NS	58-0002-408845	1	RPM Y-Alarm Cord	815 - 1215

STOP & SHIFT ELECTRICAL SYSTEM

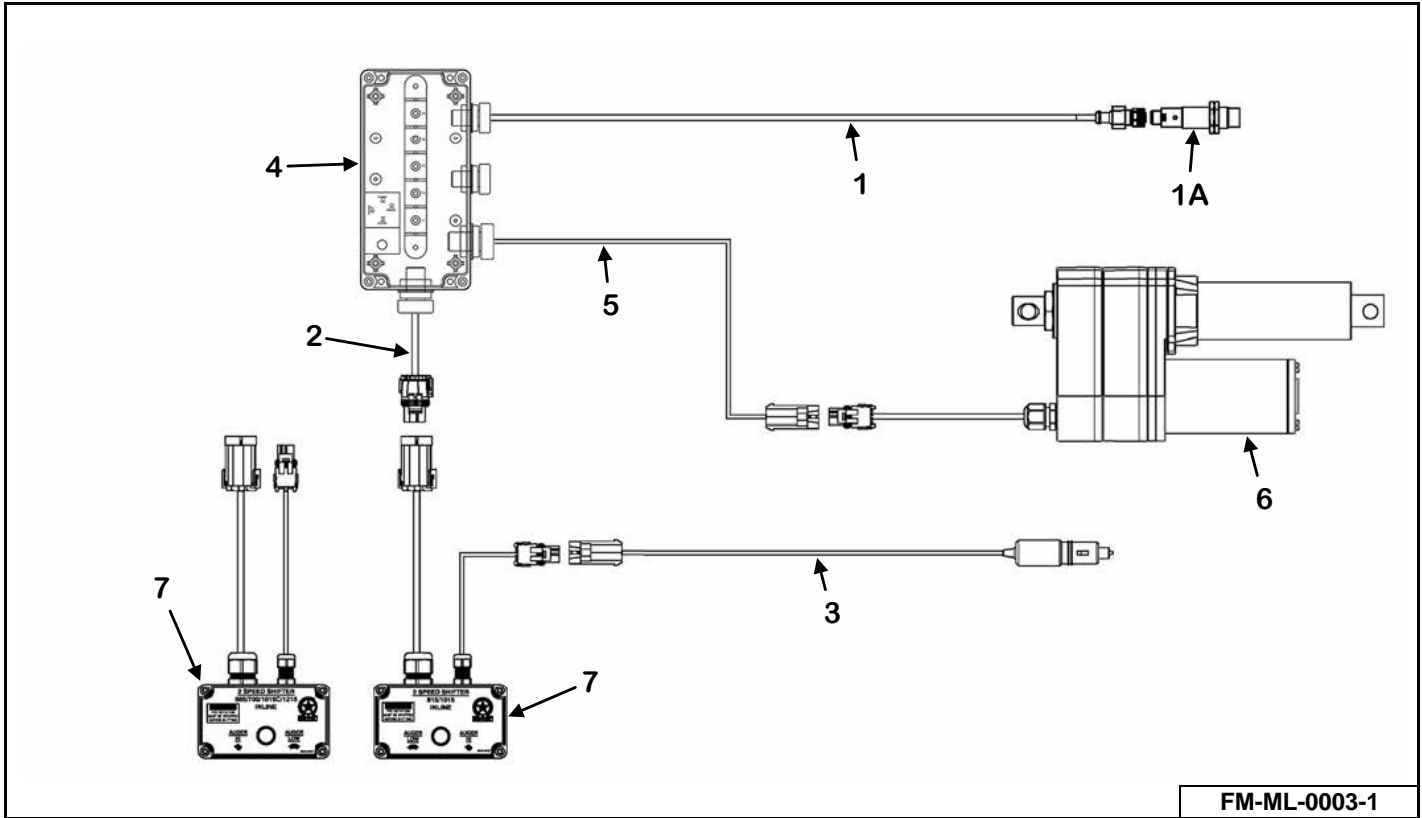

STOP & SHIFT WIRING SCHEMATIC

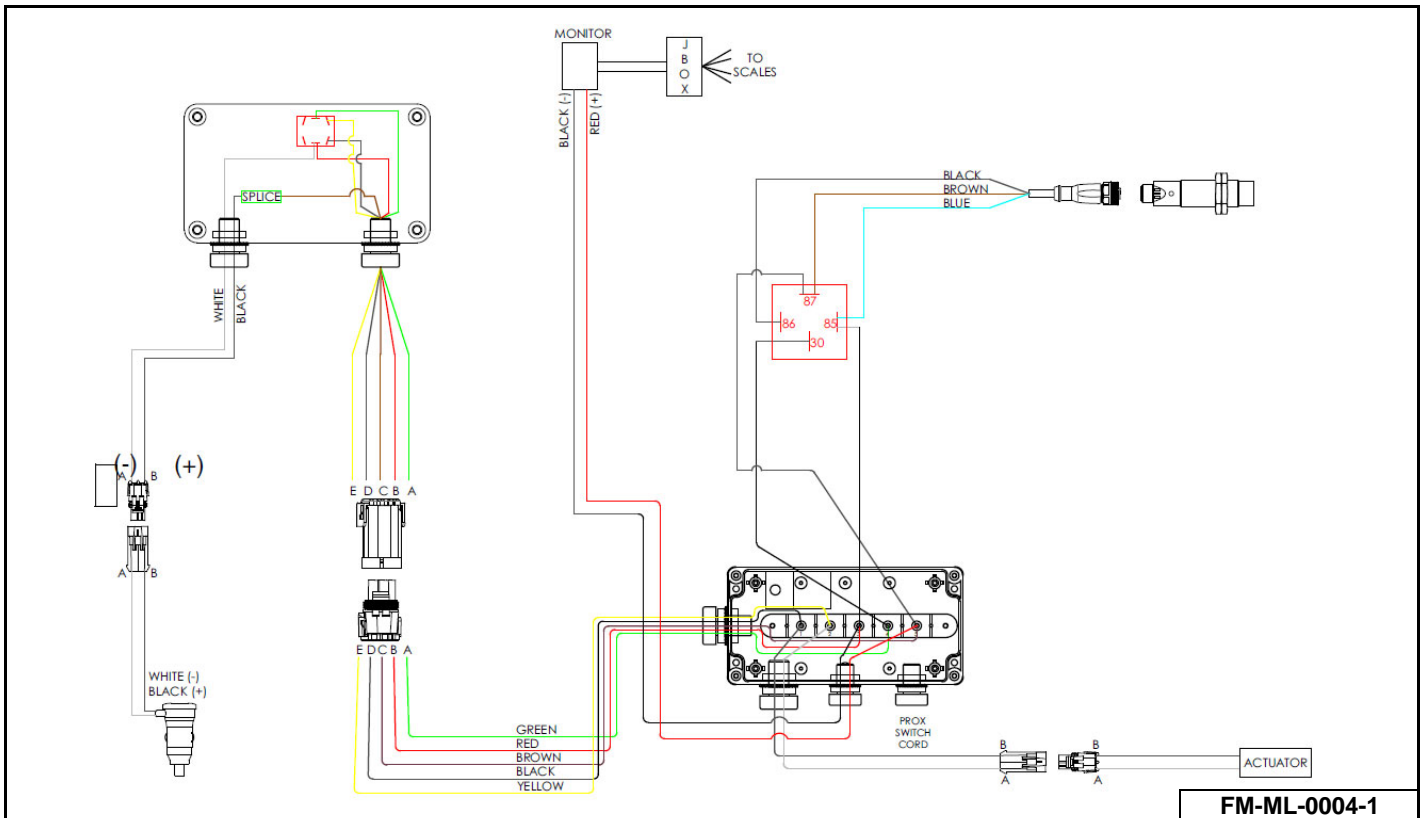

KEY	PART NUMBER	QTY	DESCRIPTION	MIXER MODEL
1	56-0202	1	Proximity Switch Assembly	815 - 1215
1A	56-0200-1	1	Proximity Switch	815 - 1215
2	56-0205	1	5-Wire Tractor to Junction Power Cord	815 - 1215
3	56-0204	1	2-Speed Power Cord Assembly	815 - 1215
	56-0136	1	3-Pin Aux Power Cord Assembly (Optional)	815 - 1215
	VA-BBL	1	Battery Box Package (Optional)	815 - 1215
	656-0001-2	1	10 Amp 250V Fuse	815 - 1215
4	56-0280	1	7-Terminal Enclosure	815 - 1215
	56-0200-3	1	Normally Open Relay	815 - 1215
5	56-0203	1	2-Speed Actuator Power Cord, Front Discharge	815 - 1215
	56-0223	1	2-Speed Actuator Power Cord, Side Discharge	815 - 1215
6	56-0123	1	12V Linear Actuator With Plug	815 - 1215
7	56-0283	1	2-Speed Control Box	815/1015
	56-0282	1	2-Speed Control Box ASM	815P/1015P/ 1015C/1215

POWER SHIFT ELECTRICAL SYSTEM
 (SN 21VM1215205, 21VM1215206 & 22VM1215201)

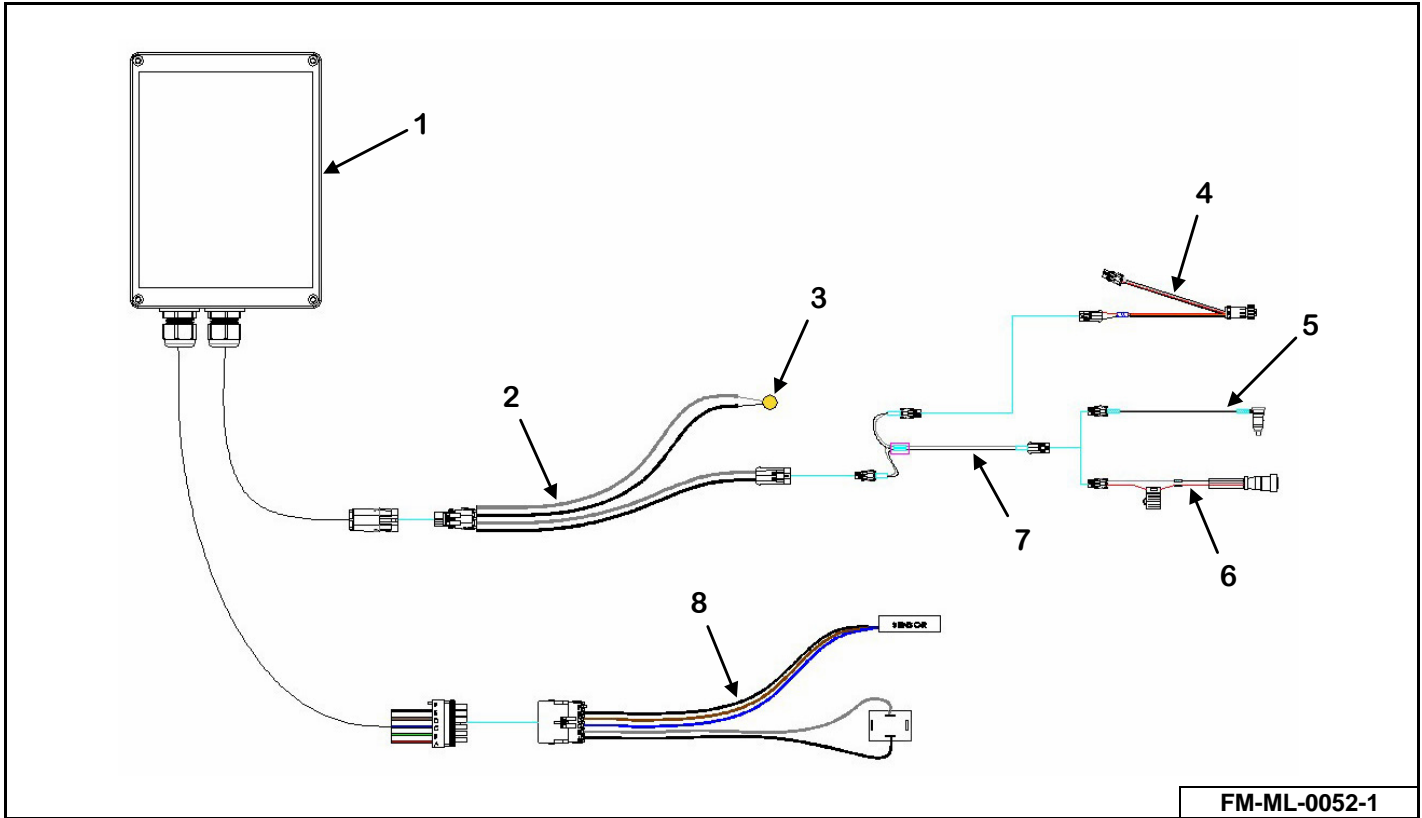

POWER SHIFT ELECTRICAL SYSTEM
 (SN 22VM1215203 & LATER)

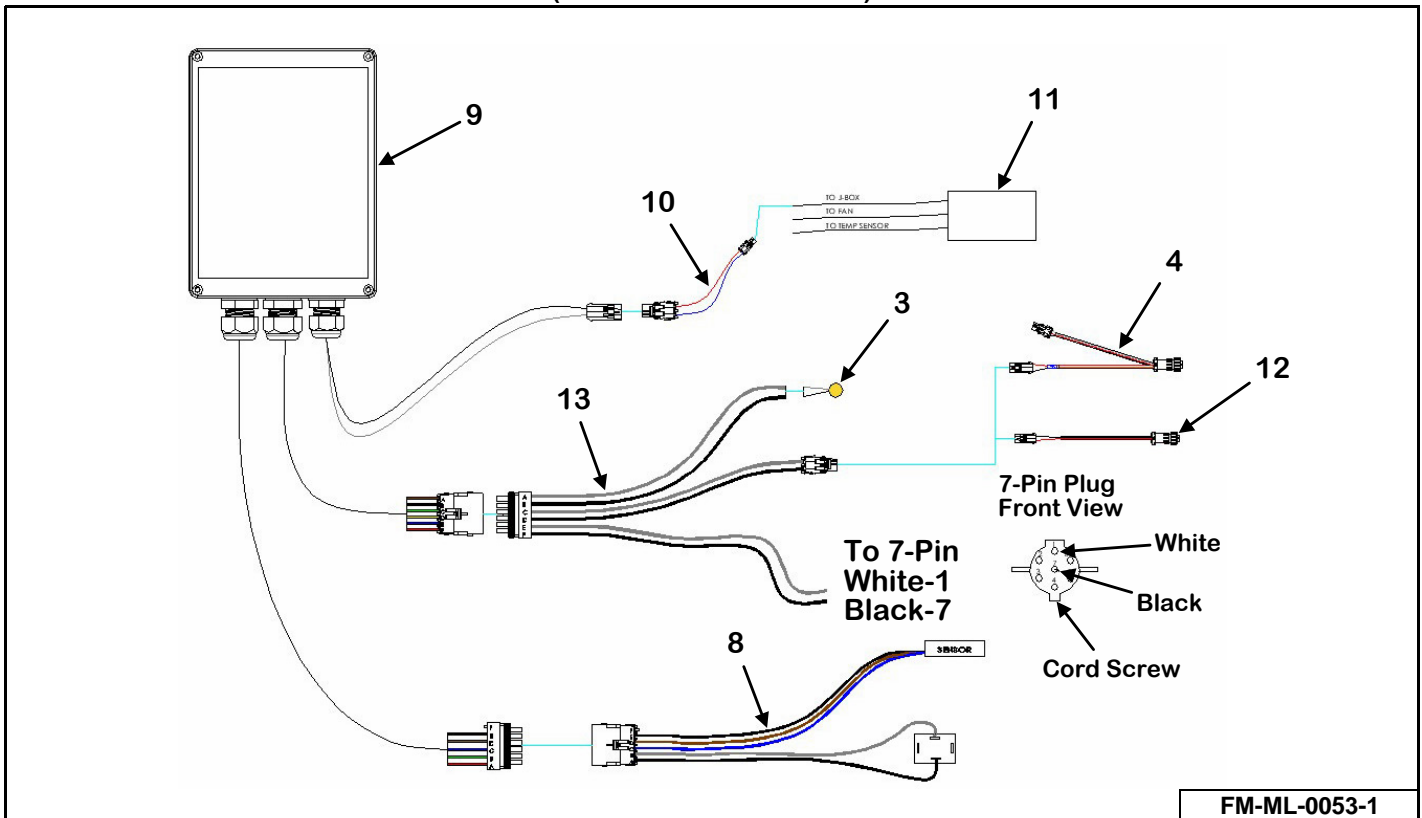

KEY	PART NUMBER	QTY	DESCRIPTION	MIXER MODEL
1	56-0385	1	Junction Box Assembly	815 - 1215
2	56-0386	1	Light/Power Harness Assembly	815 - 1215
3	56-0111-BT	1	Amber Light	815 - 1215
4	56-0381	1	Monitor Y-Harness (Optional)	815 - 1215
5	56-0360	1	12V Power Cord	815 - 1215
6	56-0361	1	3-Pin Power Cord	815 - 1215
7	56-0372	1	Y-Harness	815 - 1215
8	56-0375	1	Coil/Sensor Harness Assembly	815 - 1215
9	See Page 88	1	Junction Box Assembly (SN 22VM1215203 Through 2024 Model Year)	815 - 1215
	See Page 89	1	Junction Box Assembly (2025 Model Year & Later)	815 - 1215
10	56-0461	1	Fan Harness Assembly	815 - 1215
11	155-OC-TT07-1-1	1	Temperature Control Kit	815 - 1215
12	56-0459	1	No Rotational Counter Monitor Harness Assembly (Optional)	815 - 1215
13	56-0376	1	Light/Power Harness Assembly	815 - 1215

POWER SHIFT JUNCTION BOX
(SN 22VM1215203 Through 2024 Model Year)

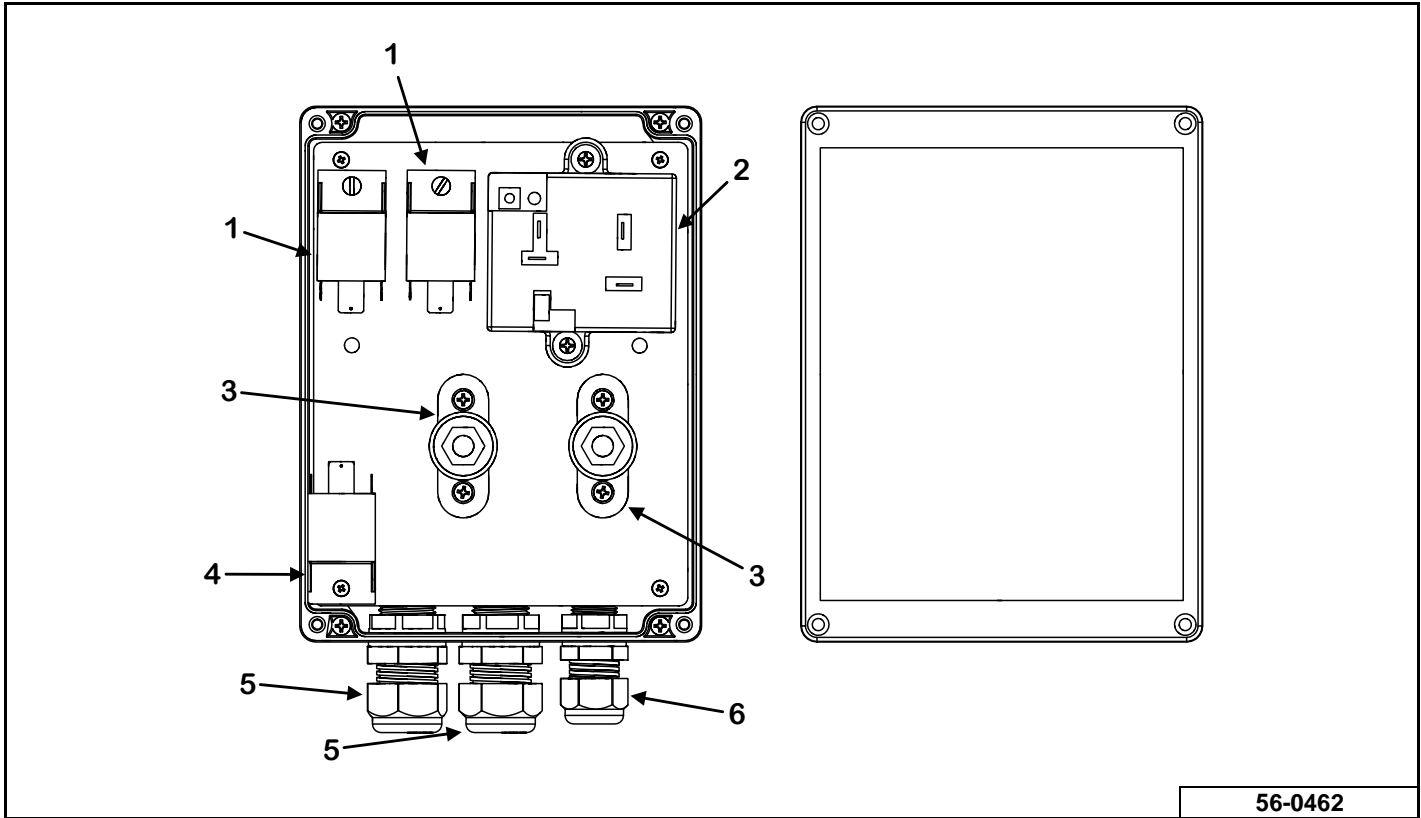

56-0462

KEY	PART NUMBER	QTY	DESCRIPTION	MIXER MODEL
0	56-0601	1	Junction Box Assembly	815 - 1215
1	56-0200-3	2	70A Relay	815 - 1215
2	56-0350	1	Remote Control Receiver Assembly	815 - 1215
3	56-0433	2	Junction Block Stud	815 - 1215
4	56-0428	1	30/50A Relay	815 - 1215
5	156-CG-08-2	2	Cord Grip	815 - 1215
6	156-CG-06-1	1	Cord Grip	815 - 1215

POWER SHIFT JUNCTION BOX
(2025 Model Year & LATER)

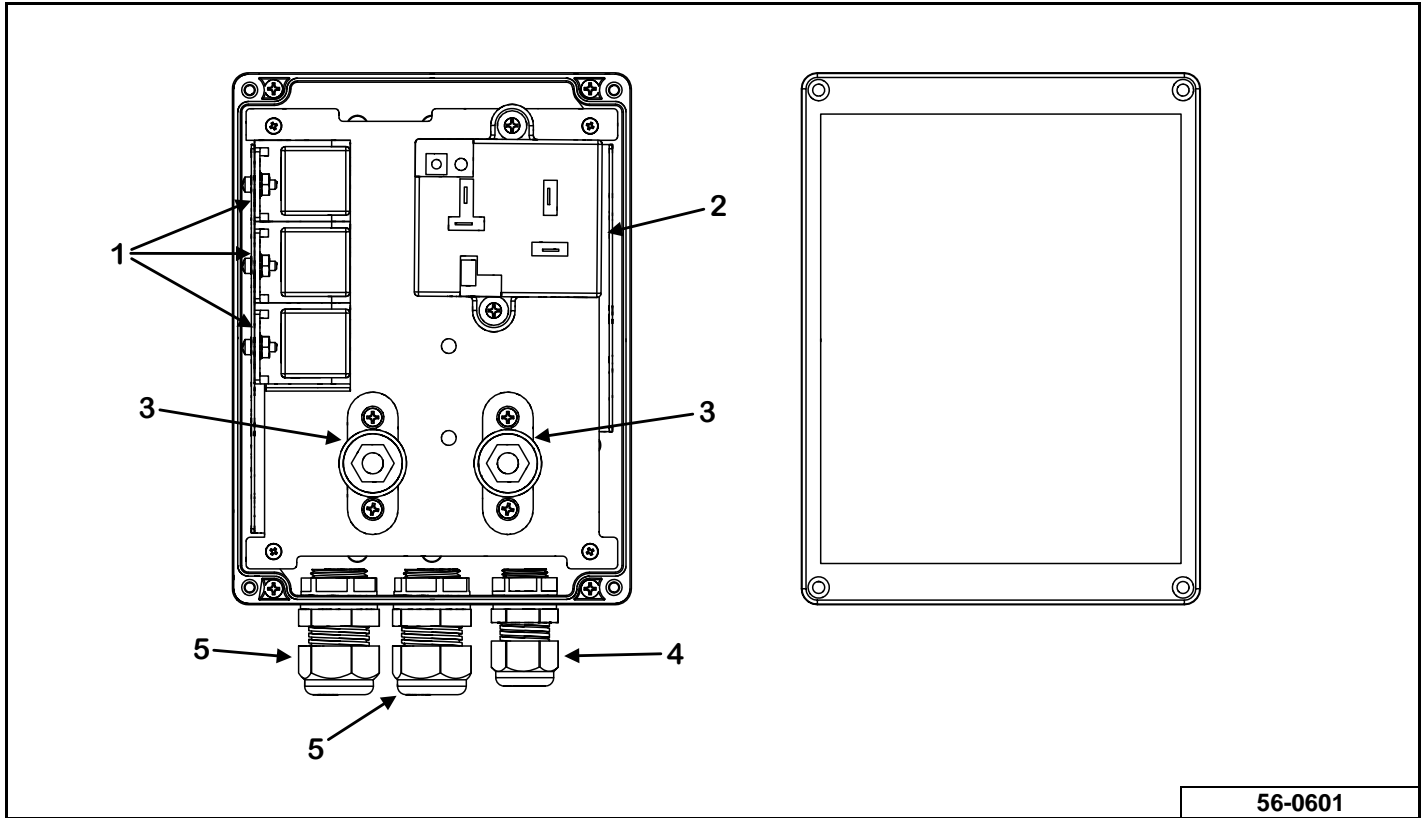

KEY	PART NUMBER	QTY	DESCRIPTION	MIXER MODEL
0	56-0601	1	Junction Box Assembly	815 - 1215
1	56-0501-2	3	50A Relay	815 - 1215
2	56-0350	1	Remote Control Receiver Assembly	815 - 1215
3	56-0433	2	Junction Block Stud	815 - 1215
4	156-CG-06-1	1	Cord Grip	815 - 1215
5	156-CG-08-2	2	Cord Grip	815 - 1215

SINGLE AXLE TRAILER

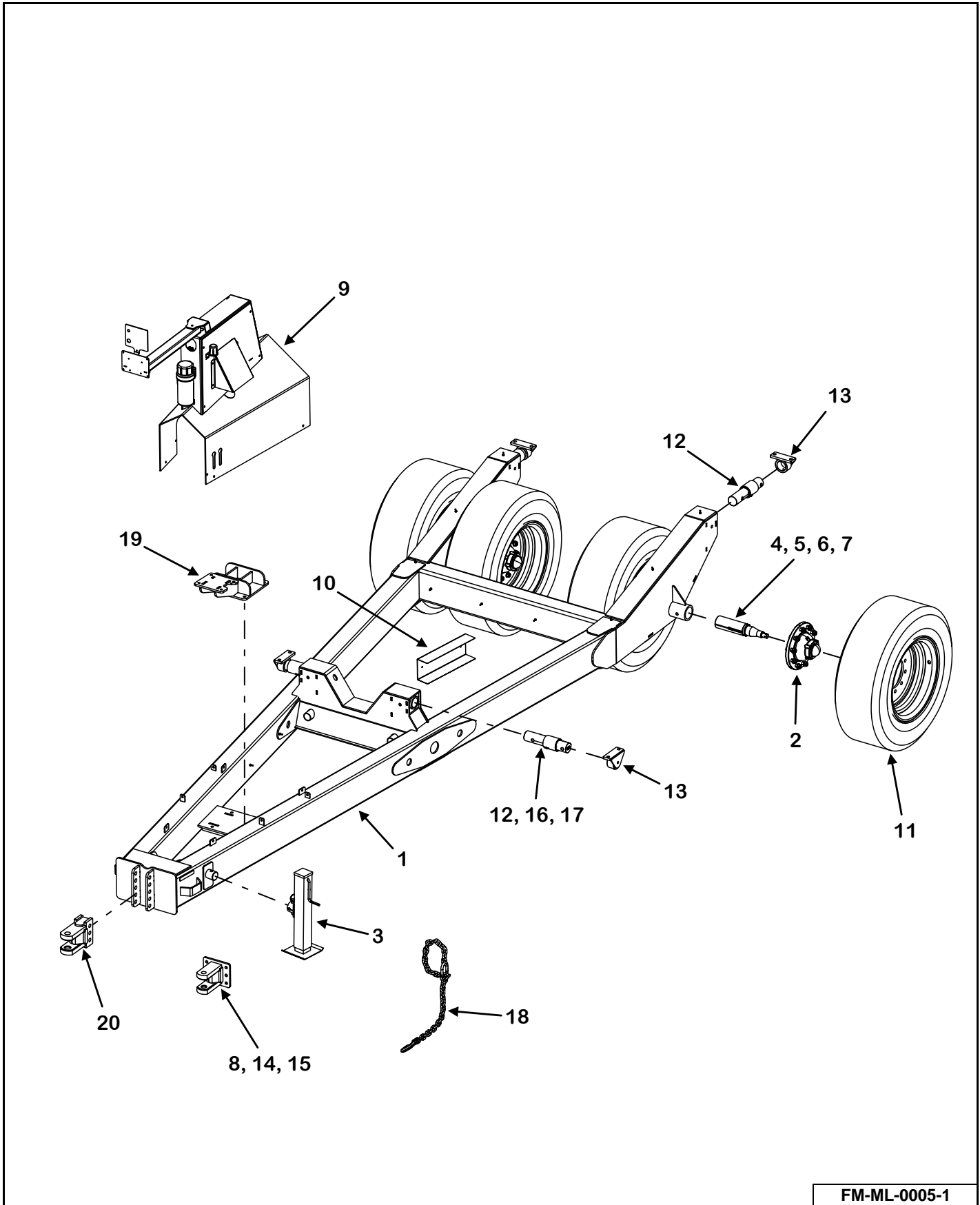

FM-ML-0005-1

KEY	PART NUMBER	QTY	DESCRIPTION	MIXER MODEL
1	M1-10-0012-1	1	Single Axle Trailer Frame Assembly (Side Discharge) (Stop & Shift Only)	815/1015
	M1-8-0006-1	1	Single Axle Trailer Frame Assembly (Front Discharge) (Stop & Shift Only)	815/1015
	M1-10-0025-1	1	Single Axle Trailer Frame Assembly (Side Discharge) (Power Shift Only)	815/1015
	M1-10-0024-1	1	Single Axle Trailer Frame Assembly (Front Discharge) (Power Shift Only)	815/1015
	M1-12-0005-1	1	Single Axle Trailer Frame Assembly (Side Discharge) (Stop & Shift Only)	1215
	M1-12-0001-1	1	Single Axle Trailer Frame Assembly (Front Discharge) (Stop & Shift Only)	1215
	M1-12-0029-1	1	Single Axle Trailer Frame Assembly (Side Discharge) (Power Shift Only)	1215
	M1-12-0027-1	1	Single Axle Trailer Frame Assembly (Front Discharge) (Power Shift Only)	1215
2	See Page 102	4	Hub, 15,000# Capacity	815/1015
	See Page 103	4	Oil Bath Hub, 20,000# Capacity	1215
	See Page 104	4	Oil Bath Hub, 22,500# Capacity (Brake Trailer)	1215
3	956-3804	1	10,000# Square Jack Without Mount Tube	815 - 1215
4	M1-8-0002-AS	4	Spindle, 3.475 x 12.75" With Nut, Washer, Cotter Pin	815/1015
	75-0116	4	Spindle, 4.474 x 16" With Nut, Washer, Cotter Pin	1215
	M1-12-0024-AS	4	Spindle, 4.464 x 18.5" With Nut, Washer, Cotter Pin, Brake Mounting Flange (Brake Trailer)	1215
5	75-0208-7	4	Spindle Washer	815/1015
	75-0213-12	4	Spindle Washer	1215
	75-0218-2	4	Spindle Washer (Brake Trailer)	1215
6	75-0208-8	4	Spindle Nut	815/1015
	75-0213-13	4	Spindle Nut	1215
	75-0218-4	4	Spindle Nut (Brake Trailer)	1215
7	823-25-3Z	4	Cotter Pin	815/1015
	75-0213-14	4	Cotter Pin	1215
	75-0218-3	4	Cotter Pin (Brake Trailer)	1215

SINGLE AXLE TRAILER (CONT'D)

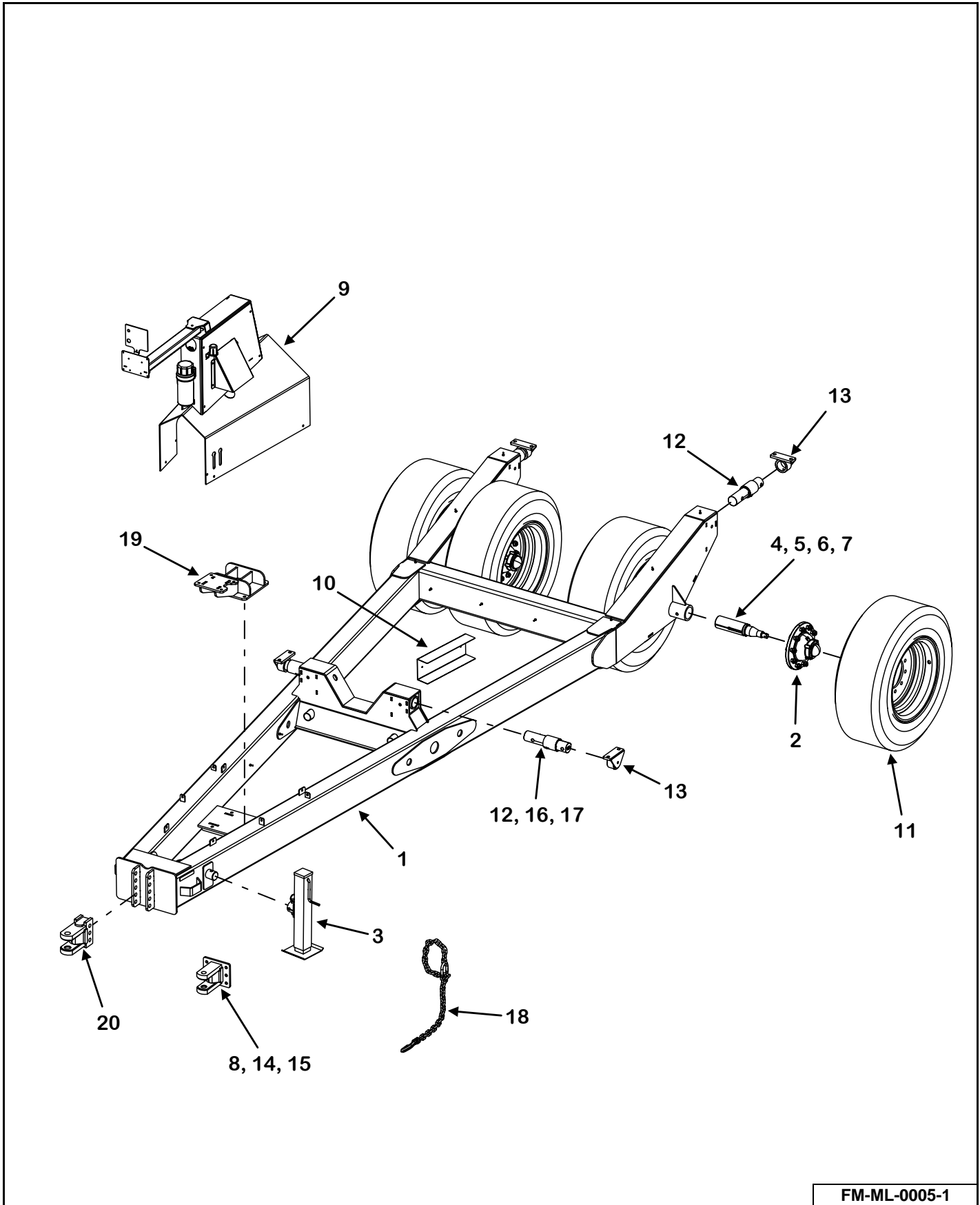

FM-ML-0005-1

KEY	PART NUMBER	QTY	DESCRIPTION	MIXER MODEL
8	M1-8-0010	1	Adjustable Hitch Front Plate	815 - 1215
9	See Page 100	1	PTO Shroud	815 - 1215
10	M11-7-0007	1	Load Cell Wire Storage Cover	815 - 1215
11	Call 1-800-325-9103	4	Tire & Wheel	815 - 1215
12	See Page 82	4	2.875" x 14" Load Cell	815 - 1215
13	See Page 82	4	DB Bar Mount	815 - 1215
14	881-7510-1.75Z	6	3/4"-10 x 1-1/2" Machine Bolt Grade 8	815 - 1215
15	822-0075-Z	6	3/4" Split Lock Washer	815 - 1215
16	851-7510-5.5Z	4	3/4"-10 x 5-1/2" Grade 5 M Bolt Zinc	815/1015
	851-7510-7Z	4	3/4"-10 x 7" Grade 5 M Bolt Zinc (Side Discharge)	1215
	851-7510-6Z	4	3/4"-10 x 6" Grade 5 M Bolt Zinc (Front Discharge)	1215
17	815-7510-Z	4	3/4"-10 Nylon Insert Lock Nut	815 - 1215
18	52-0051	1	Safety Chain, 40,000# Capacity	815/1015
	52-0052	1	Safety Chain, 60,000# Capacity	1215
19	M1-12-0028	1	Power Shift Transmission Mount (Power Shift Models Only)	815 - 1215
20	75-4054-1	1	Adjustable Hitch Front Plate (Power Shift Models Only)	815 - 1215

TANDEM AXLE TRAILER

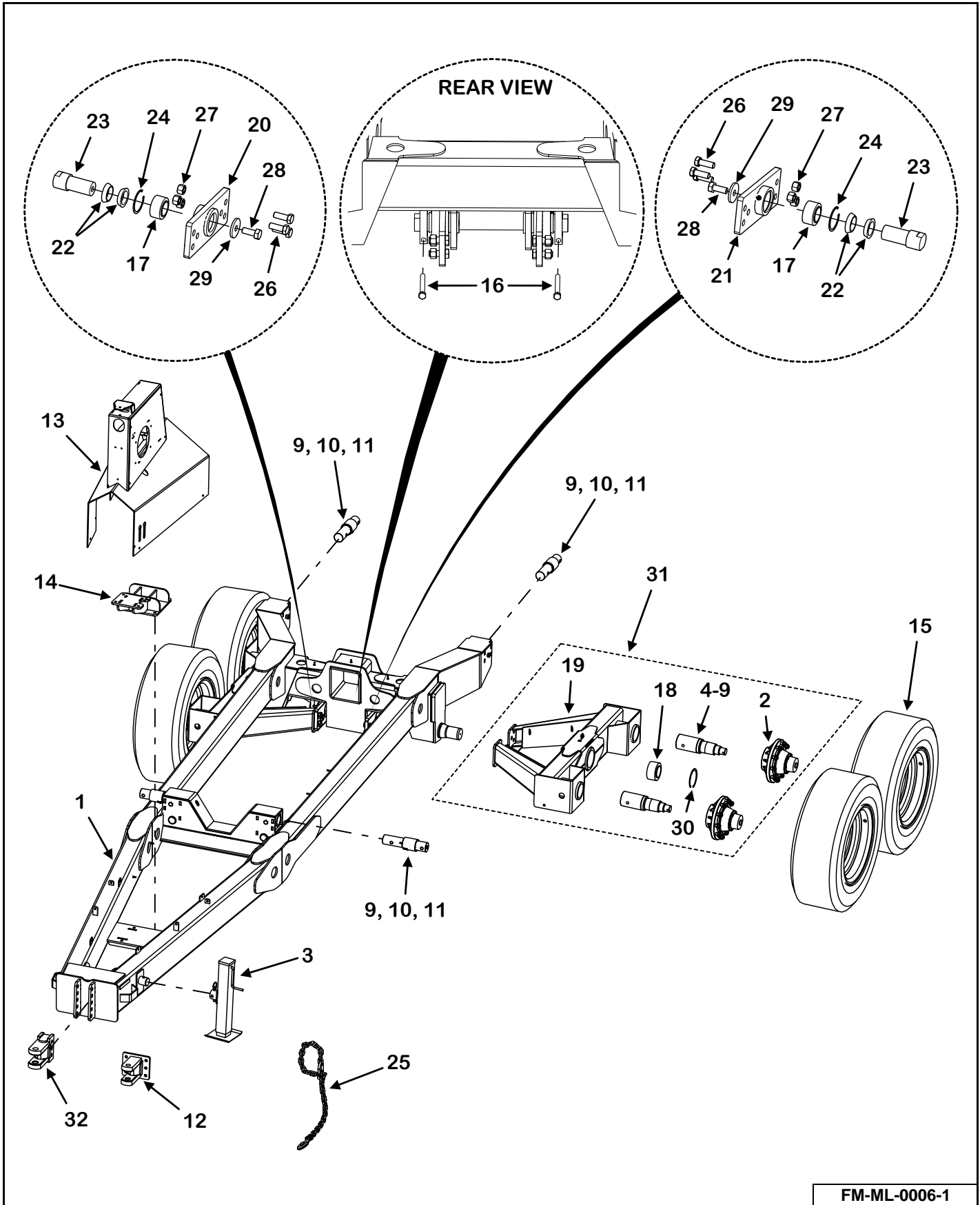

FM-ML-0006-1

KEY	PART NUMBER	QTY	DESCRIPTION	MIXER MODEL
1	M1-10-0016-1	1	Tandem Axle Trailer Frame Assembly (Side Discharge) (Stop & Shift Only)	815/1015
	M1-10-0022-1	1	Tandem Axle Trailer Frame Assembly (Front Discharge) (Stop & Shift Only)	815/1015
	M1-10-0026-1	1	Tandem Axle Trailer Frame Assembly (Side Discharge) (Power Shift Only)	815/1015
	M1-10-0028-1	1	Tandem Axle Trailer Frame Assembly (Front Discharge) (Power Shift Only)	815/1015
	M1-12-0013-1	1	Tandem Axle Trailer Frame Assembly (Side Discharge) (Stop & Shift Only)	1215
	M1-12-0020-1	1	Tandem Axle Trailer Frame Assembly (Front Discharge) (Stop & Shift Only)	1215
	M1-12-0031-1	1	Tandem Axle Trailer Frame Assembly (Side Discharge) (Power Shift Only)	1215
	M1-12-0030-1	1	Tandem Axle Trailer Frame Assembly (Front Discharge) (Power Shift Only)	1215
2	See Page 102	4	Hub, 15,000# Capacity	815/1015
	See Page 103	4	Oil Bath Hub, 20,000# Capacity	1215
3	956-3804	1	10,000# Square Jack With Storage Mount Tube	815 - 1215
4	75-0111-3-AS	4	Spindle, 3.480 x 16.219" With Nut, Washer, Cotter Pin	815/1015
	75-0116-2	4	Spindle, 4.474 x 15.50" With Nut, Washer, Cotter Pin	1215
	75-0117	4	Brake Spindle, 4.480 x 16.219" With Nut, Washer, Cotter Pin	1215
5	75-0208-7	4	Spindle Washer	815/1015
	75-0213-12	4	Spindle Washer	1215
	75-0208-7	4	Spindle Washer (Brake Trailer)	1215
6	75-0208-8	4	Spindle Nut	815/1015
	75-0213-13	4	Spindle Nut	1215
	75-0208-8	4	Spindle Nut (Brake Trailer)	1215
7	823-25-3Z	4	Cotter Pin	815/1015
	75-0213-14	4	Cotter Pin	1215
	823-25-3Z	4	Cotter Pin (Brake Trailer)	1215

TANDEM AXLE TRAILER (CONT'D)

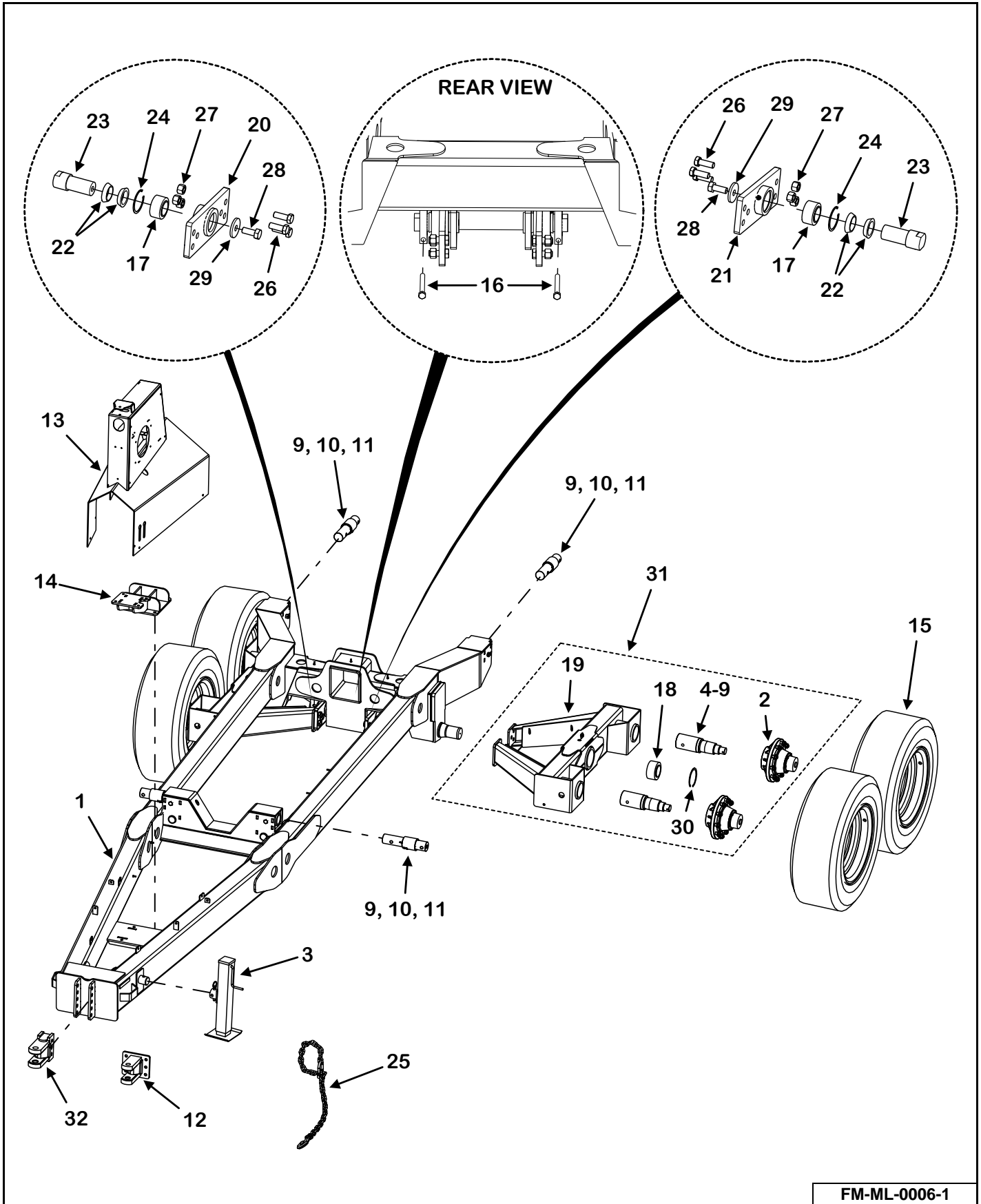

FM-ML-0006-1

KEY	PART NUMBER	QTY	DESCRIPTION	MIXER MODEL
8	851-7510-7Z	4	3/4-10 x 7" Bolt	815 - 1215
9	815-7510-Z	8	3/4-10 Nylon Insert Lock Nut	815 - 1215
10	881-7510-8Z	4	3/4"-10 x 8" Bolt	815 - 1215
11	See Page 82	4	2.875" x 14" Load Cell	815 - 1215
12	M1-8-0010	1	Adjustable Hitch Front Plate (Stop & Shift Models Only)	815 - 1215
	881-7510-1.75Z	6	3/4"-10 x 1-1/2" Machine Bolt Grade 8	815 - 1215
	822-0075-Z	6	3/4" Split Lock Washer	815 - 1215
13	See Page 100	1	PTO Shroud	815 - 1215
14	M1-12-0028	1	Power Shift Transmission Mount (Power Shift Models Only)	815 - 1215
15	Call 1-800-325-9103	4	Call Factory With Model Information	815 - 1215
16	881-7510-7Z	2	3/4"-10 x 7" Machine Bolt Grade 8	815 - 1215
	814-7510-Z	2	3/4"-10 Center Lock Nut	815 - 1215
17	114-VM-0002	2	Plain Spherical Bearing 2.5" ID Motion	815 - 1215
18	914-3822	2	Sealed Spherical Bearing 3" ID x 4.75" OD x 2.625"	815 - 1215
	114-VM-0003	2	Sealed Spherical Bearing 3.5" ID x 5.5" OD X 3.062"	1215
19	M1-10-0021-NHS	2	Tandem O-Beam Assembly (Including Key #'s 18 & 30)	815/1015
	M1-12-0010-NHS	2	Tandem O-Beam Assembly (Including Key #'s 18 & 30)	1215
	M1-12-0010B-NHS	2	Tandem Brake O-Beam Assembly (Including Key #'s 18 & 30)	1215
20	M1-12-0017	1	Right Tandem Inner Bearing Weldment With Grease Fittings	815 - 1215
21	M1-12-0018	1	Left Tandem Inner Bearing Weldment With Grease Fittings	815 - 1215
22	M1-10-0004-1-1	4	Tandem Inner Bearing Torque Collar	815 - 1215
23	M1-10-0004-1-2	2	Tandem Inner Bearing Pin	815 - 1215
24	33-0056	2	Internal Snap Ring Fits 3.938" ID Tube	815 - 1215
25	52-0051	1	Safety Chain, 40,000# Capacity	815/1015
	52-0052	1	Safety Chain, 60,000# Capacity	1215
26	851-1008-2.75Z	12	1"-8 x 2-3/4" Bolt	815 - 1215
27	884-1008	12	1"-8 Lock Nut	815 - 1215
28	881-1014-2.5Z	2	1"-14 x 2-1/2" Bolt (Torque to 500 ft./lbs. lubricated)	815 - 1215
29	M1-10-0004-1-3	2	Inner Bearing Washer	815 - 1215

TANDEM AXLE TRAILER (CONT'D)

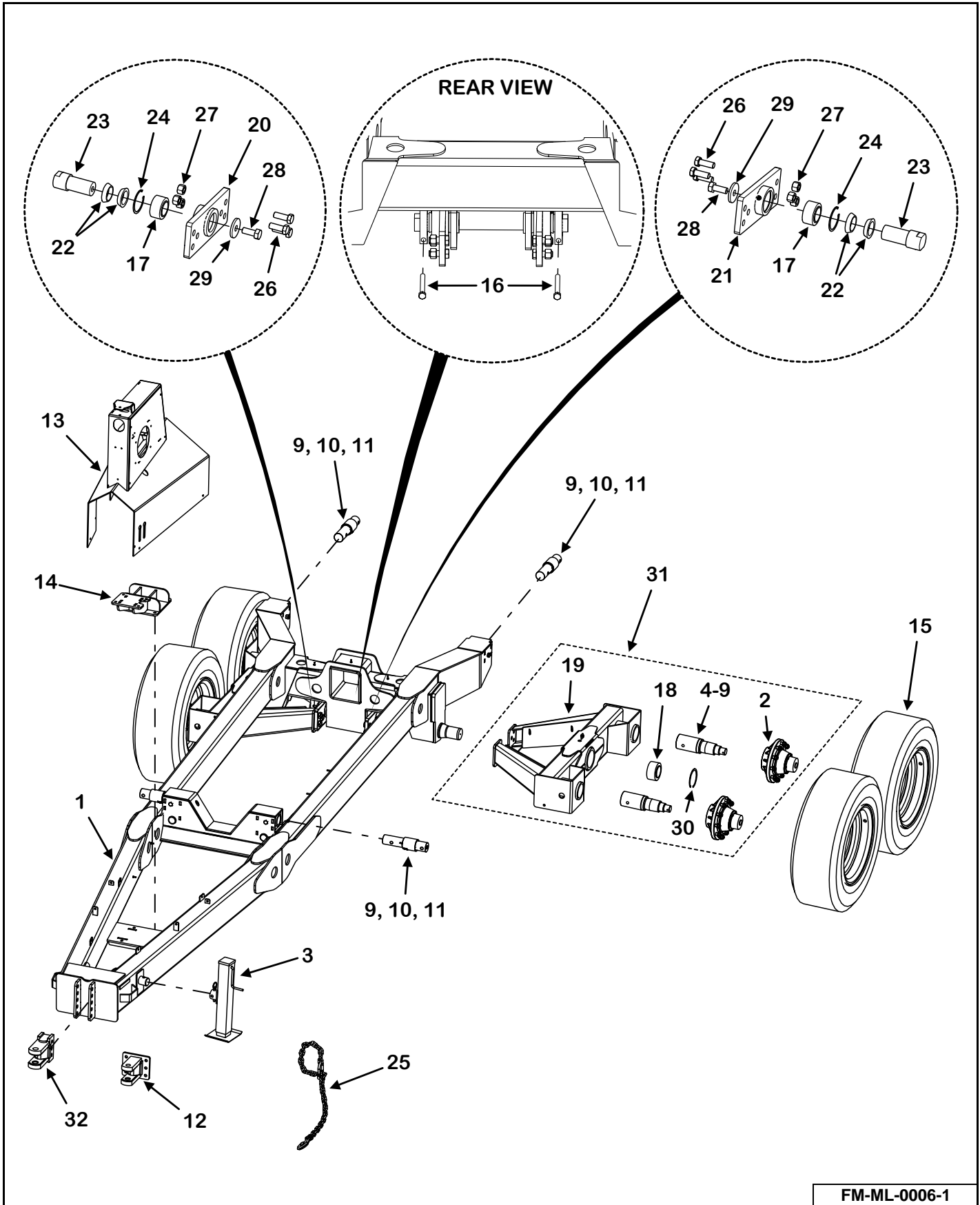

FM-ML-0006-1

KEY	PART NUMBER	QTY	DESCRIPTION	MIXER MODEL
30	33-0057	4	4-3/4" Internal Snap Ring	815/1015
	33-0058	4	5-1/2" Internal Snap Ring	1215
31	M1-10-0021-R	1	Right Tandem O-Beam Assembly (Including Key #'s 17, 20, 24, 26 & 27)	815/1015
	M1-10-0021-NHR	1	Right Tandem O-Beam Assembly Without Hubs (Including Key #'s 17, 20, 24, 26 & 27)	815/1015
	M1-10-0021-L	1	Left Tandem O-Beam Assembly (Including Key #'s 17, 21, 24, 26 & 27)	815/1015
	M1-10-0021-NHL	1	Left Tandem O-Beam Assembly Without Hubs (Including Key #'s 17, 21, 24, 26 & 27)	815/1015
	M1-12-0010-R	1	Right Tandem O-Beam Assembly (Including Key #'s 17, 20, 24, 26 & 27)	1215
	M1-12-0010-NHR	1	Right Tandem O-Beam Assembly Without Hubs (Including Key #'s 17, 20, 24, 26 & 27)	1215
	M1-12-0010-L	1	Left Tandem O-Beam Assembly (Including Key #'s 17, 21, 24, 26 & 27)	1215
	M1-12-0010-NHL	1	Left Tandem O-Beam Assembly Without Hubs (Including Key #'s 17, 21, 24, 26 & 27)	1215
	M1-12-0010B-R	1	Right Tandem Brake O-Beam Assembly With Brake Assemblies (Including Key #'s 17, 20, 24, 26 & 27)	1215
	M1-12-0010B- NHR	1	Right Tandem Brake O-Beam Assembly Without Hubs (Including Key #'s 17, 20, 24, 26 & 27)	1215
	M1-12-0010B-L	1	Left Tandem Brake O-Beam Assembly (Including Key #'s 17, 21, 24, 26 & 27)	1215
	M1-12-0010B- NHL	1	Left Tandem Brake O-Beam Assembly With Brake Assemblies (Including Key #'s 17, 21, 24, 26 & 27)	1215
32	75-4054-1	1	Adjustable Hitch Front Plate (Power Shift Models Only)	815 - 1215

STOP & SHIFT PTO SHROUD

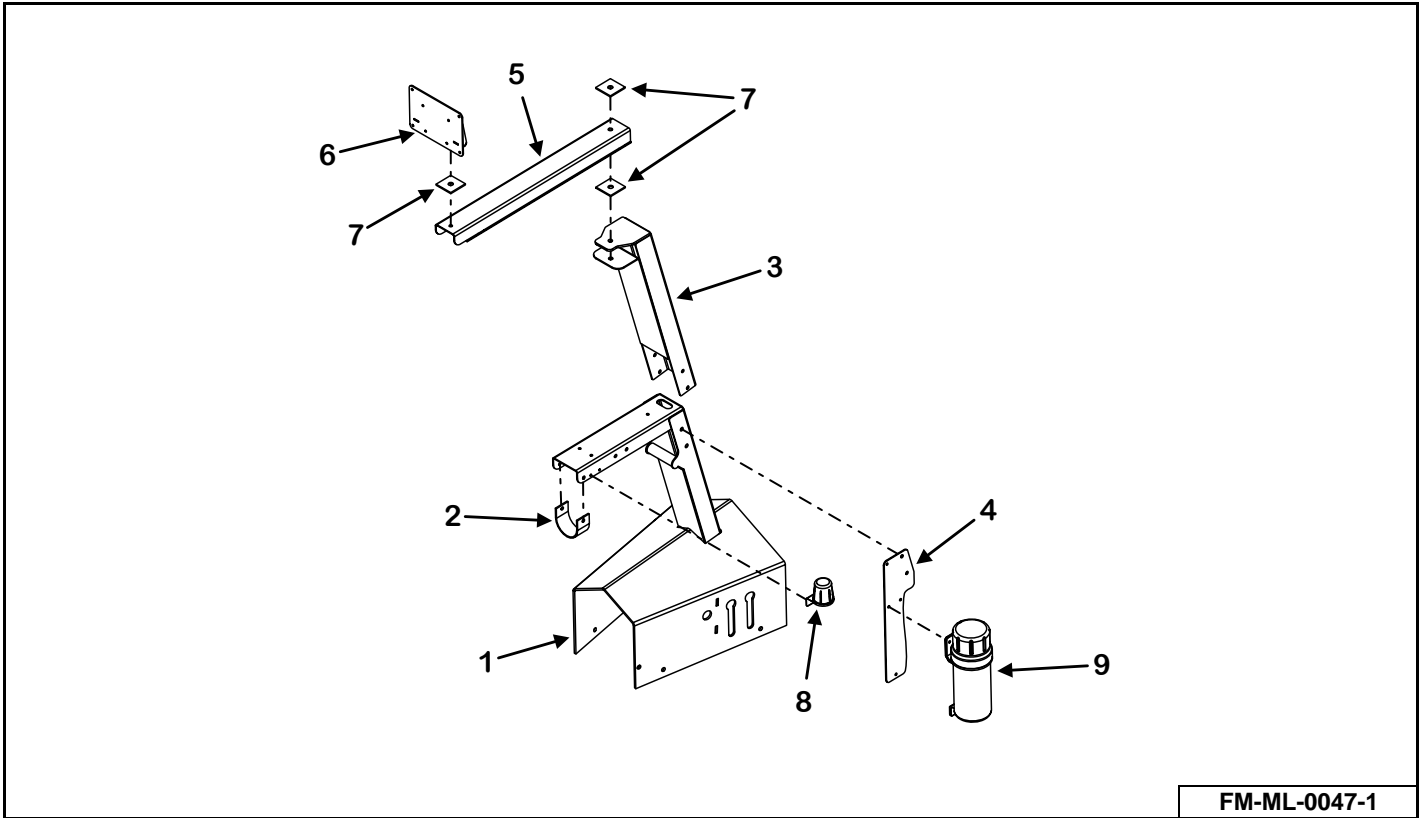

POWER SHIFT PTO SHROUD

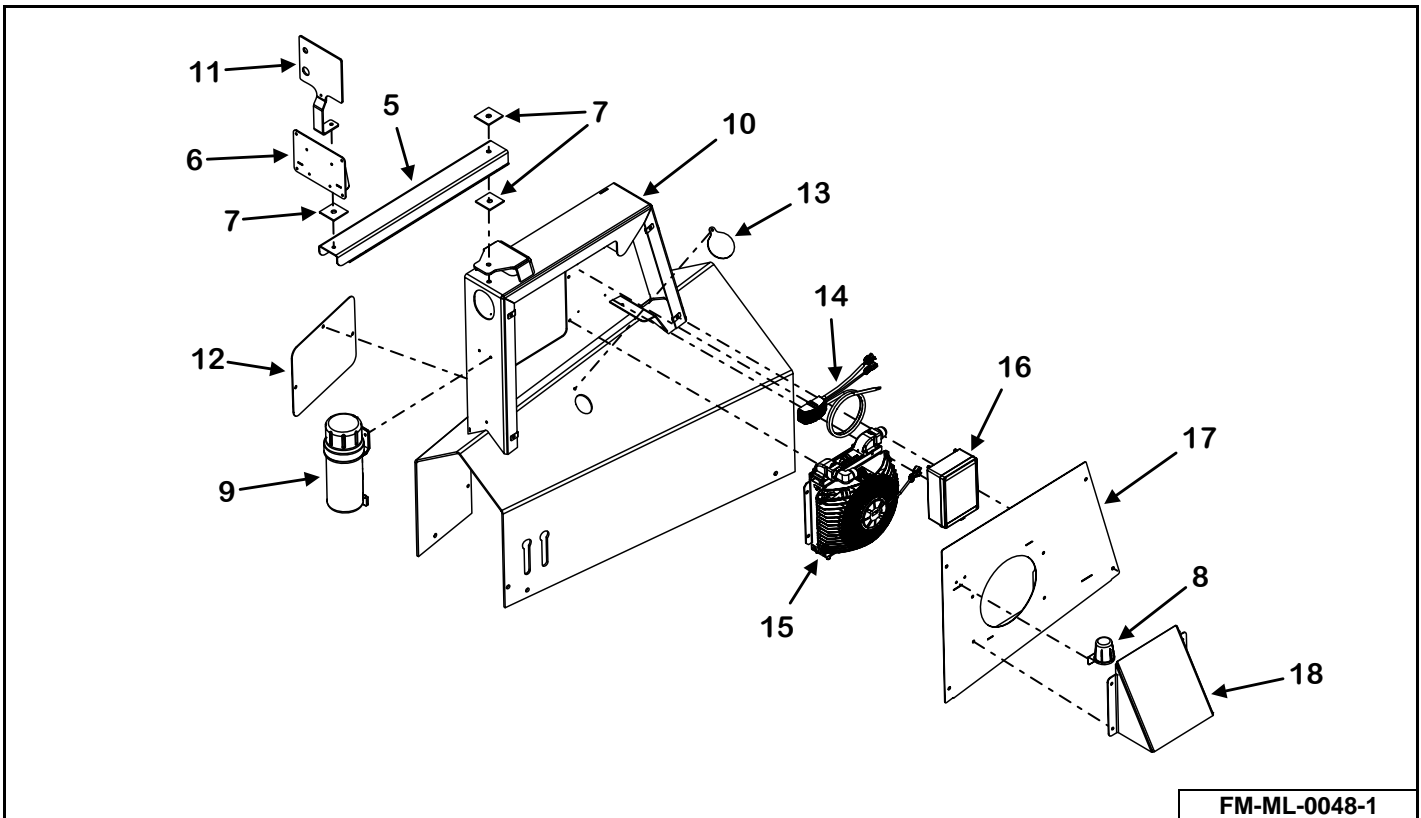

KEY	PART NUMBER	QTY	DESCRIPTION	MIXER MODEL
1	M8-1-8-0009	1	PTO Shroud (Side Discharge) (Single Axle Trailer)	815 - 1215
	M8-1-8-0003	1	PTO Shroud (Front Discharge) (Single Axle Trailer)	815 - 1215
	M8-10-0009-1	1	PTO Shroud (Front Discharge) (Tandem Axle Trailer)	815 - 1215
	M8-12-0001-1	1	PTO Shroud (Side Discharge) (Tandem Axle Trailer)	815 - 1215
2	M8-1-8-0006-7	1	Rubber Hose Holder	815 - 1215
3	M9-1-8-0007	1	Scale Mount Extension Weldment (Without Platform Only)	815 - 1215
4	M8-1-4-0004	1	Manual Holder Mount	815 - 1215
5	M9-1-4-0001	1	Load Display Pivot Arm (Without Platform Only)	815 - 1215
6	M9-1-8-0002	1	Scale Indicator Mount (Without Platform Only)	815 - 1215
7	M9-1-8-0004	3	Scale Arm Rubber Washer (Without Platform Only)	815 - 1215
8	56-0009	1	Plug Holder	815 - 1215
9	33-0060	1	Manual Holder	815 - 1215
10	M8-12-0006	1	PTO Shroud (Side Discharge) (Single Axle Trailer)	815 - 1215
	M8-12-0005	1	PTO Shroud (Front Discharge) (Single Axle Trailer)	815 - 1215
	M8-12-0008	1	PTO Shroud (Side Discharge) (Tandem Axle Trailer)	815 - 1215
	M8-12-0007	1	PTO Shroud (Front Discharge) (Tandem Axle Trailer)	815 - 1215
11	MN11-1-0002-3	1	Indicator Light Bracket	815 - 1215
12	MN11-1-0002-1	1	Filter Cover Plate	815 - 1215
13	925-0608-1-3	1	Shield Cover	815 - 1215
14	See Page 86	1	Temperature Control Kit	815 - 1215
15	See Page 86	1	12V Hydraulic Cooler	815 - 1215
16	See Page 86	1	Cooling Junction Box Assembly	815 - 1215
17	MN11-1-0004	1	Heat Exchanger Housing Cover Weldment	815 - 1215
18	MN11-1-0029	1	Cover	815 - 1215

75-0219 HUB ASSEMBLY

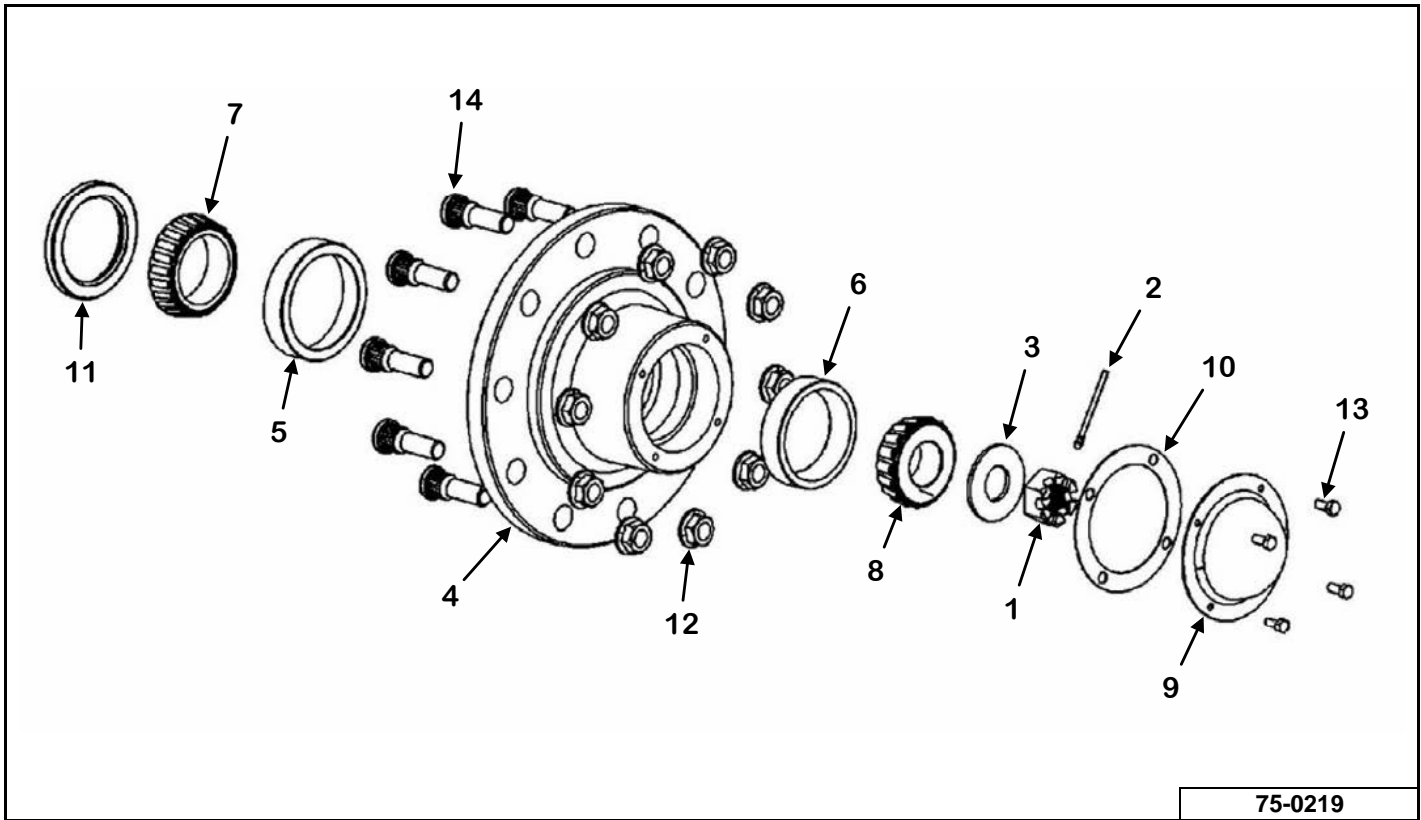

KEY	PART NUMBER	QTY	DESCRIPTION
0	75-0219	1	Hub Assembly
1	75-0208-8	1	Castle Nut
2	823-25-3Z	1	Cotter Pin
3	75-0208-7	1	Washer
4	75-0219-1	1	Hub with Bearing Races
5	75-0211-4	1	Inner Wheel Race
6	75-0208-5	1	Outer Wheel Race
7	75-0211-3	1	Inner Wheel Bearing Cone
8	75-0208-6	1	Outer Wheel Bearing Cone
9	75-0208-10	1	Hub Cap
10	75-0208-14	1	Hub Cap Gasket
11	75-0211-2	1	Grease Seal
12	75-0208-11	10	3/4"-16 Lug Nut-Flanged, Grade 8, Torque 378 ft/lbs
13	75-0208-13	4	Hex Bolt, 0.3125-18 x .75
14	75-0208-12	10	3/4"-16 Lug Bolt

75-0217 OIL BATH HUB ASSEMBLY

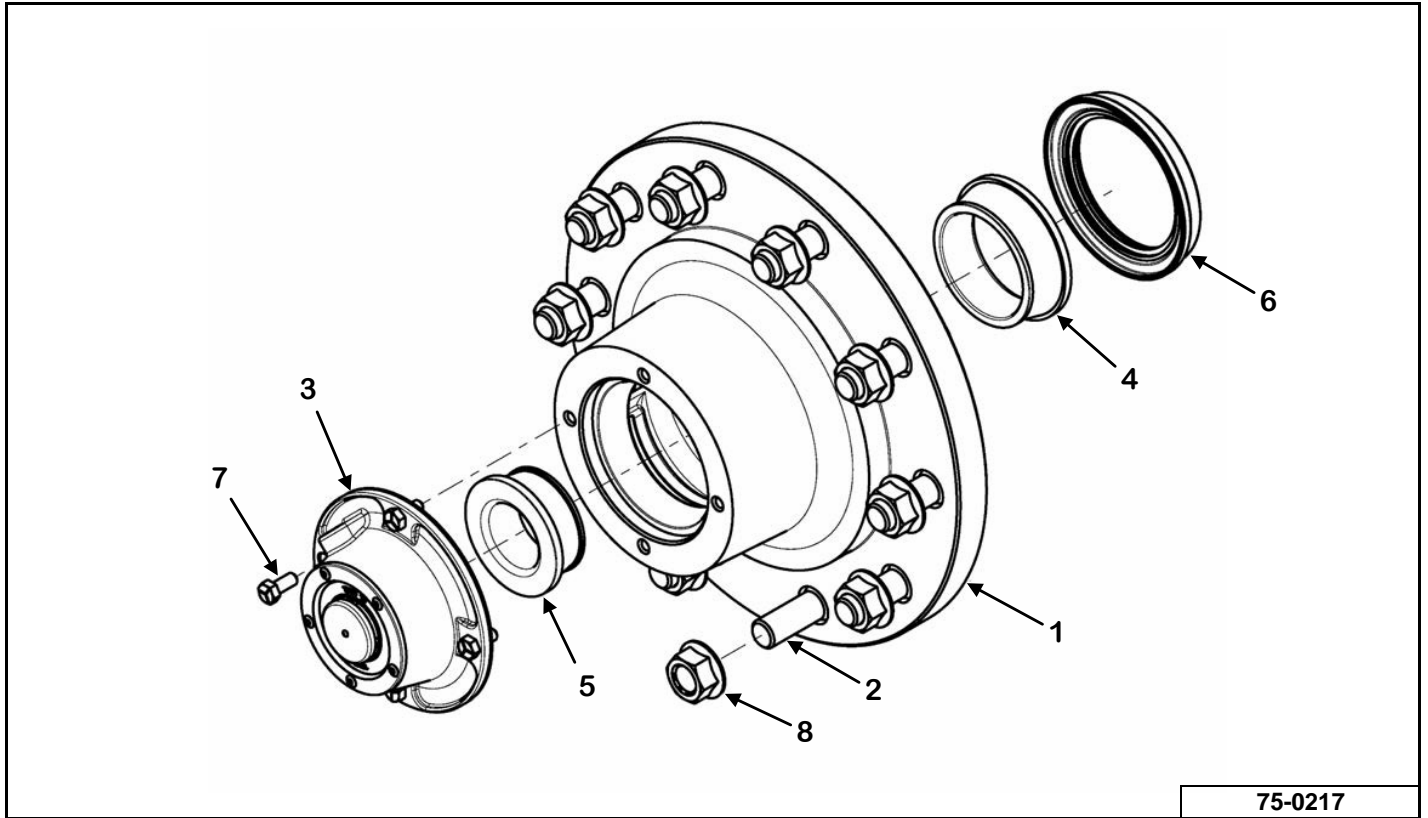

KEY	PART NUMBER	QTY	DESCRIPTION
0	75-0217	1	Hub Assembly
1	75-0217-1	1	Hub Only
	75-0213-10	1	Inner Bearing Cup
	75-0213-3	1	Outer Bearing Cup
2	75-0208-12	10	Bolt Stud 3/4-16 UNF x 2-3/4", Grade 8
3	75-2410-1-1-1-3	1	25K Oil Hub Cap With Gasket
	75-2410-1-1-1-9	1	Gasket Only
4	975-0200-3-1	1	Inner Bearing Cone
5	975-0200-3-2	1	Outer Bearing Cone
6	75-0217-2	1	Oil Bath Seal
7	851-3118-.75Z	6	Bolt Hex 5/16"-18 UNC x 3/4" LG, Grade 5
8	75-0208-11	10	Hex Flange Nut - 3/4"-16 UNF, Grade 8, Torque 378 ft/lbs
NS	75-0213-12	1	Washer
NS	75-0213-13	1	Spindle Nut
NS	75-0213-14	1	Cotter Pin

75-0218 OIL BATH HUB ASSEMBLY

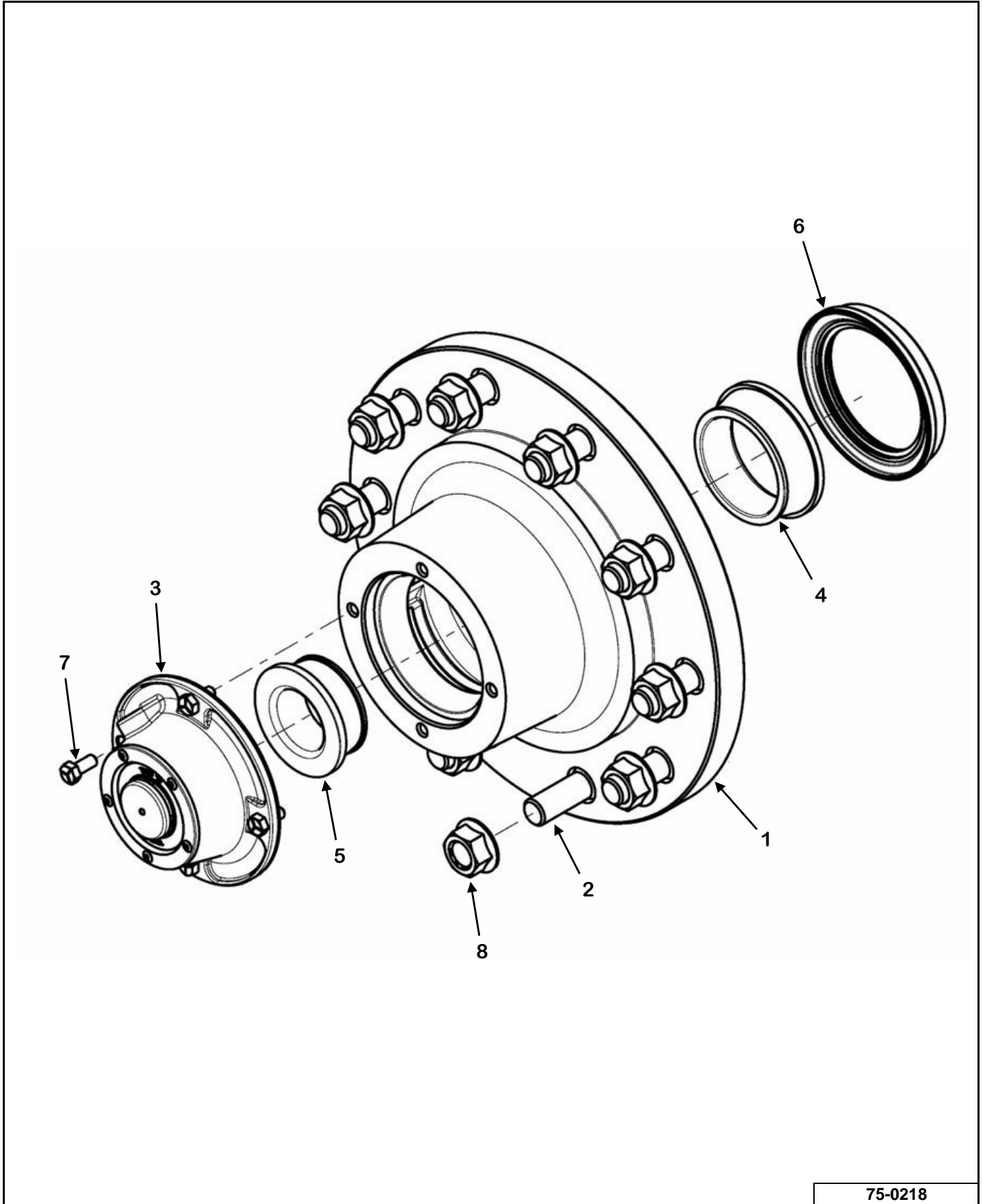

75-0218

KEY	PART NUMBER	QTY	DESCRIPTION
0	75-0218	1	Hub Assembly
1	75-0218-1	1	Hub
	75-0218-6	1	Inner Bearing Cup
	75-0218-7	1	Outer Bearing Cup
2	75-0208-12	10	Bolt Stud 3/4-16 UNF x 2-3/4", Grade 8
3	75-2410-1-1-1-3	1	25K Oil Hub Cap With Gasket
	75-2410-1-1-1-9	1	Gasket
4	75-0218-8	1	Inner Bearing Cone
5	75-0218-9	1	Outer Bearing Cone
6	75-0218-5	1	Oil Bath Seal
7	851-3118-.75Z	6	Bolt Hex 5/16-18 UNC x 3/4" LG, Grade 5
8	75-0208-11	10	Hex Flange Nut - 3/4-16 UNF, Grade 8, Torque 378 ft/lbs
NS	75-0218-2	1	Washer
NS	75-0218-4	1	Spindle Nut
NS	75-0218-3	1	Cotter Pin

MIXER
815 - 1215

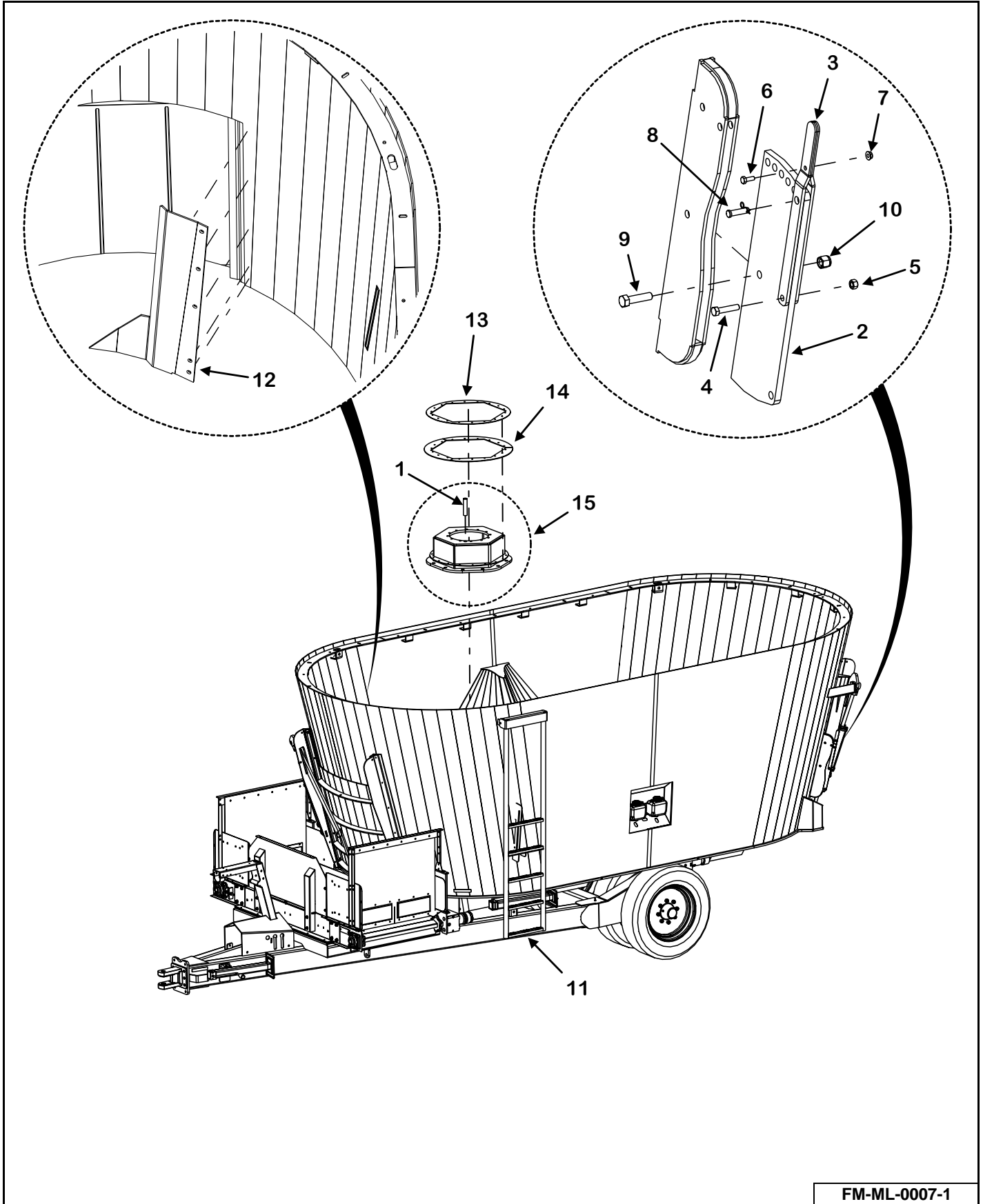

FM-ML-0007-1

KEY	PART NUMBER	QTY	DESCRIPTION	MIXER MODEL
1	M2-1-7-0003-3	2	Planetary Mount Tube (Welded On)	815 - 1015
	M2-1-10-0002-4	2	Planetary Mount Tube (Welded On)	1015C/1215
2	M7-1-8-0002	2	Hay Stop	815 - 1215
3	M7-1-8-0003	4	Hay Stop Handle	815 - 1215
4	851-3816-1.75Z	2	3/8"-16 x 1-3/4" Machine Bolt	815 - 1215
5	815-3816-Z	2	3/8"-16 Nylon Insert Lock Nut	815 - 1215
6	851-2520-.75Z	2	1/4"-20 x 3/4" Machine Bolt	815 - 1215
7	810-2520-Z	2	1/4" Spin Lock Nut	815 - 1215
8	32-0042	2	1/2" x 1-1/2" Clevis Pin With Clip	815 - 1215
9	851-5013-2Z	2	1/2"-13 x 2" Machine Bolt	815 - 1215
10	815-5013-Z	2	1/2"-13 Nylon Lock Nut	815 - 1215
11	See Page 158	1	Ladder Weldment	815 - 1215
12	M6-1-8-0018	1	Front/Rear Door Deflector	815 - 1215
	803-3816-1.25Z	5	3/8"-16 x 1-1/4" Flat Head Socket Cap Screw	815 - 1215
	815-3816-Z	5	3/8"-16 Nylon Insert Lock Nut	815 - 1215
13	M2-1-8-0035-3	2	Auger Seal Cover	815 - 1215
	851-3816-1Z	36	3/8"-16 x 1" Machine Bolt	815 - 1215
	815-3816-Z	36	3/8"-16 Nylon Lock Nut	815 - 1215
14	M2-1-8-0035-2	6	Auger Seal Belting	815 - 1215
15	M2-1-10-0003	2	Planetary Mount Weldment (Stop & Shift Models)	815/1015
	M2-1-10-0002	2	Planetary Mount Weldment (Stop & Shift Models)	1015C/1215
	M2-1-10-0020	2	Planetary Mount Weldment (Power Shift Models)	815 - 1215

FRONT FLAT & INCLINE BASE BELT CONVEYOR

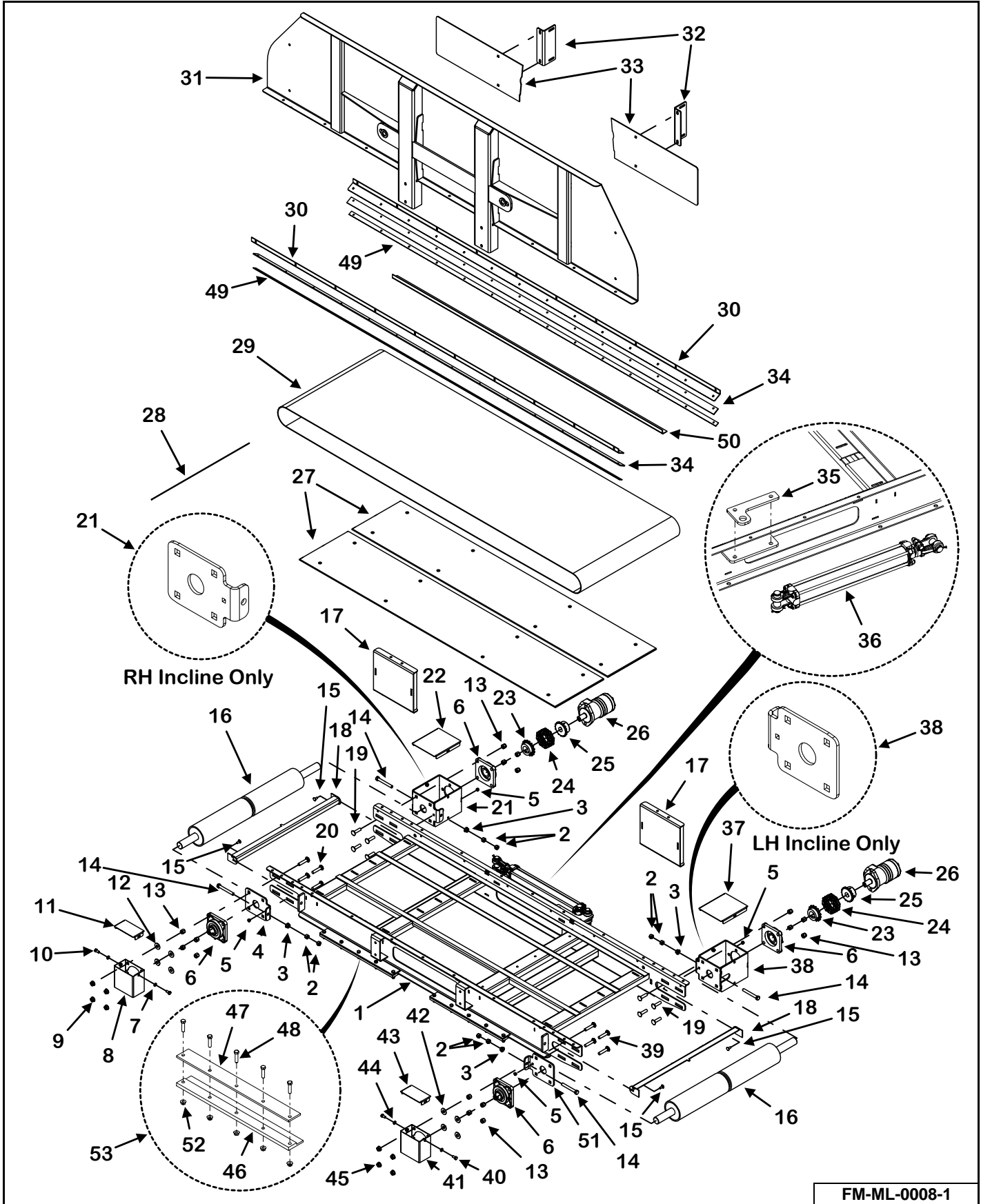

FM-ML-0008-1

KEY	PART NUMBER	QTY	DESCRIPTION	MIXER MODEL
0	VAL-FDB-36-2MI	1	2 Motor Front Discharge Flat Belt Conveyor (Incline Ready)	815 - 1215
	VAL-FDBI-3636-L3	1	3 Motor Front LH Discharge Incline Belt Conveyor (36" Incline)	815 - 1215
	VAL-FDBI-3636-R3	1	3 Motor Front RH Discharge Incline Belt Conveyor (36" Incline)	815 - 1215
	VAL-FDBI-3648-L3	1	3 Motor Front LH Discharge Incline Belt Conveyor (48" Incline)	815 - 1215
	VAL-FDBI-3648-R3	1	3 Motor Front RH Discharge Incline Belt Conveyor (48" Incline)	815 - 1215
	VAL-FDBI-3672-L3	1	3 Motor Front LH Discharge Incline Belt Conveyor (72" Incline)	815 - 1215
	VAL-FDBI-3672-R3	1	3 Motor Front RH Discharge Incline Belt Conveyor (72" Incline)	815 - 1215
1	M3-1-10-0017-1	1	Incline Base Conveyor Weldment	815 - 1215
2	813-5013-Z	8	1/2"-13 Nut	815 - 1215
3	810-5013-Z	4	1/2" Spin Lock Nut	815 - 1215
4	M3-1-5-0044-1	2	Front Conveyor Bearing Mount	815 - 1215
	See Page 228	1	Bearing Mount Weldment (RH Power Magnet)	815 - 1215
5	814-3118-Z	4	5/16"-18 Indented Lock Nut	815 - 1215
6	14-0070	4	1-1/2" 4-Bolt Bearing Narrow Inner Race	815 - 1215
7	822-0038-Z	2	3/8" Split Lock Washer (No Incline, LH Incline)	815 - 1215
8	M3-1-8-0047	1	Shaft Cover Weldment (No Incline, LH Incline)	815 - 1215
9	810-5013-Z	4	1/2" Spin Lock Nut (No Incline, LH Incline)	815 - 1215
10	851-3816-.75Z	2	3/8"-16 x 3/4" Machine Bolt (No Incline, LH Incline)	815 - 1215
11	M3-1-8-0048	1	Shaft Cover Plate (No Incline, LH Incline)	815 - 1215
12	805-0050-Z	4	1/2" Flat Washer (No Incline, LH Incline)	815 - 1215
13	815-5013-Z	16	1/2"-13 Nylon Lock Nut	815 - 1215
14	830-5013-4Z	4	1/2"-13 x 4" Tap Bolt Full Threaded	815 - 1215
15	850-3118-.75Z	4	5/16"-18 x 3/4" Carriage Bolt	815 - 1215
16	23-0269	2	Drive Pulley Urethane Lagged	815 - 1215

FRONT FLAT & INCLINE BASE BELT CONVEYOR (CONT'D)

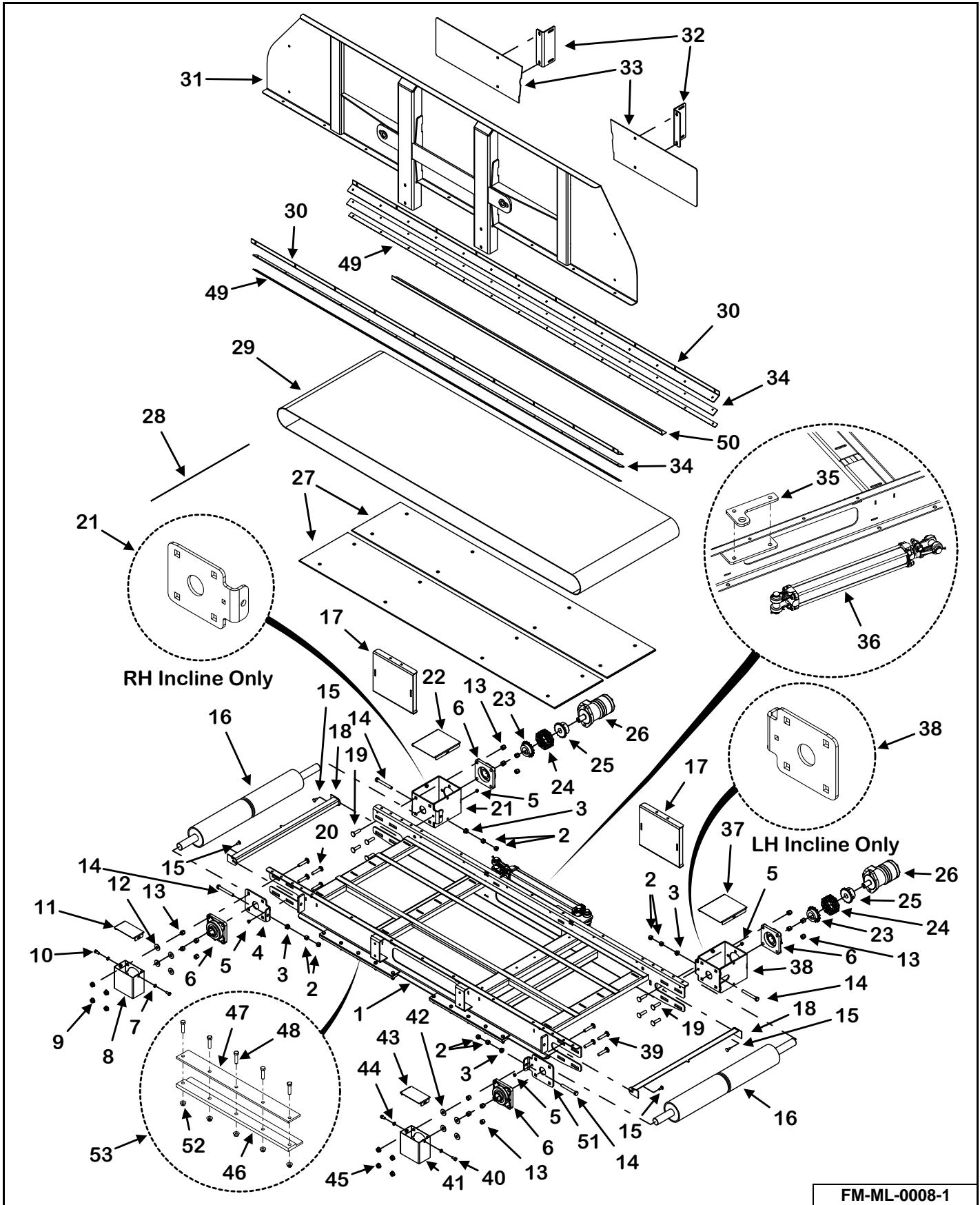

FM-ML-0008-1

KEY	PART NUMBER	QTY	DESCRIPTION	MIXER MODEL
17	M3-1-10-0022	2	Conveyor Shield Weldment (Front Flat Sliding Conveyor Only)	815 - 1215
18	M3-1-10-0023	2	Conveyor Pulley Scraper	815 - 1215
19	850-5013-1.75Z	8	1/2"-13 x 1-3/4" Carriage Bolt	815 - 1215
20	850-5013-2.25Z	4	1/2"-13 x 2-1/4" Carriage Bolt (No Incline, LH Incline)	815 - 1215
	850-5013-1.75Z	4	1/2"-13 x 1-3/4" Carriage Bolt (RH Incline)	815 - 1215
21	M3-1-8-0046	1	Front Conveyor Motor Mount Weldment (No Incline, LH Incline)	815 - 1215
	M3-1-5-0044-1	1	Front Conveyor Bearing Mount (RH Incline)	815 - 1215
	See Page 228	1	Motor Mount Weldment (RH Power Magnet)	815 - 1215
22	M3-1-8-0045	1	Chain Coupler Cover Plate (No Incline, LH Incline)	815 - 1215
	851-3816-.75Z	2	3/8"-16 x 3/4" Machine Bolt (No Incline, LH Incline)	815 - 1215
	822-0038-Z	2	3/8" Split Lock Washer (No Incline, LH Incline)	815 - 1215
23	110-50B16-1.50-1	2	Coupler Sprocket	815 - 1215
	35-0006	2	Key	815 - 1215
24	37-0013-2	2	Coupler Chain	815 - 1215
25	37-0013-1	2	Coupler Sprocket	815 - 1215
26	See Page 116	2	12.1 Cubic Inch 2-Bolt Motor	815 - 1215
	135-2525-1.25-1	2	Key	815 - 1215
27	M3-1-10-0019	2	Front Belt Discharge Conveyor Floor	815 - 1215
	803-3118-1Z	16	5/16"-18 x 1" Flat Socket Head Cap Screw	815 - 1215
	805-0031-Z	16	5/16" Flat Washer	815 - 1215
	815-3118-Z	16	5/16"-18 Nylon Insert Lock Nut	815 - 1215
28	49-0156-6-AS	1	Conveyor Belt Lacing Pin Kit	815 - 1215
29	49-0156-MB	1	Front Conveyor Mini Bite Belt	815 - 1215
30	VAL-FCS	1	Skirt Seal Kit (Prior to SN 19VM1015204, 19VM1215209) (Including SN 19VM0815201)	815 - 1215
	M3-1-10-0017-7	2	Front Conveyor Skirt Bracket SN 19VM(0815202, 1015204, 1215209) & Later	815 - 1215
31	M3-1-10-0018	1	Base Conveyor Front Panel Weldment	815 - 1215
32	M3-1-8-0028	2	Front Conveyor Shield Mounting Bracket	815 - 1215

FRONT FLAT & INCLINE BASE BELT CONVEYOR (CONT'D)

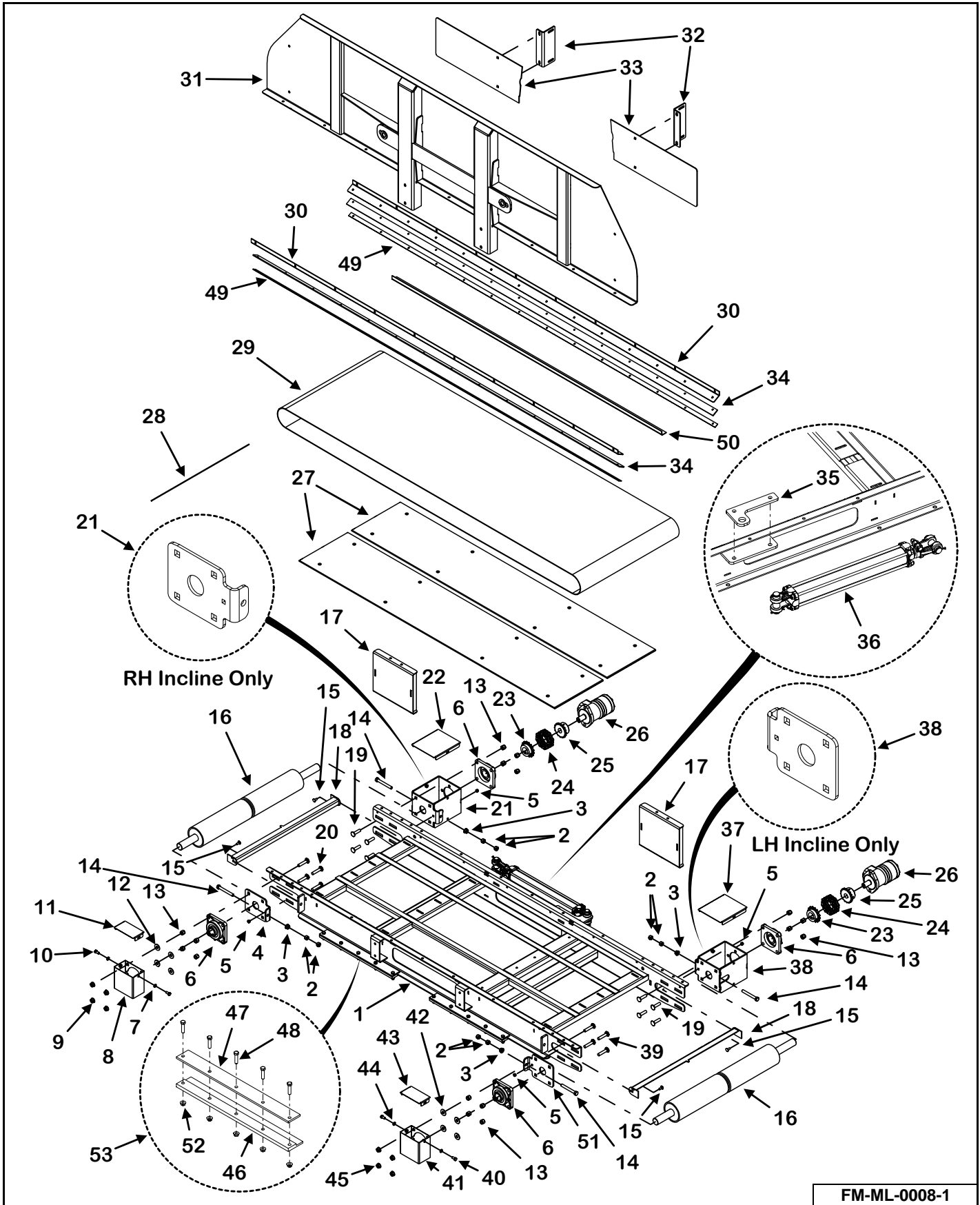

FM-ML-0008-1

KEY	PART NUMBER	QTY	DESCRIPTION	MIXER MODEL
33	M3-1-10-0009	1	Front Conveyor Shield, Left (Flat Sliding Conveyors)	815 - 1215
	M3-1-8-0012	1	Front Conveyor Shield, Left (Front Incline Conveyors)	815 - 1215
	M3-1-10-0008	1	Front Conveyor Shield, Right (Flat Sliding Conveyors)	815 - 1215
	M3-1-8-0013	1	Front Conveyor Shield, Right (Front Incline Conveyors)	815 - 1215
34	VAL-FCS	1	Skirt Seal Kit (Prior to SN 19VM1015204, 19VM1215209) (Including SN 19VM0815201)	815 - 1215
	49-0336	2	Base Conveyor Skirting SN 19VM(0815202, 1015204, 1215209) & Later	815 - 1215
35	M3-1-8-0027	1	Front Conveyor Cylinder Mount (Front Flat Sliding Conveyor Only)	815 - 1215
	851-5013-1.75Z	2	1/2"-13 x 1-3/4" Machine Bolt (Front Flat Sliding Conveyor Only)	815 - 1215
	810-5013-Z	2	1/2" Spin Lock Nut (Front Flat Sliding Conveyor Only)	815 - 1215
36	See Page 116	1	Front Flat Belt Conveyor Hydraulic Schematic	815 - 1215
37	M3-1-8-0045	1	Chain Coupler Cover Plate (No Incline, RH Incline)	815 - 1215
	851-3816-.75Z	2	3/8"-16 x 3/4" Machine Bolt (No Incline, RH Incline)	815 - 1215
	822-0038-Z	2	3/8" Split Lock Washer (No Incline, RH Incline)	815 - 1215
38	M3-1-8-0046	1	Front Conveyor Motor Mount Weldment (No Incline, RH Incline)	815 - 1215
	M3-1-5-0044-1	1	Front Conveyor Bearing Mount (LH Incline)	815 - 1215
	See Page 228	1	Motor Mount Weldment (LH Power Magnet)	815 - 1215
39	850-5013-2.25Z	4	1/2"-13 x 2-1/4" Carriage Bolt (No Incline, RH Incline)	815 - 1215
	850-5013-1.75Z	4	1/2"-13 x 1-3/4" Carriage Bolt (LH Incline)	815 - 1215
40	851-3816-.75Z	2	3/8"-16 x 3/4" Machine Bolt (No Incline, RH Incline)	815 - 1215
41	M3-1-8-0047	1	Shaft Cover Weldment (No Incline, RH Incline)	815 - 1215
42	805-0050-Z	4	1/2" Flat Washer (No Incline, RH Incline)	815 - 1215
43	M3-1-8-0048	1	Shaft Cover Plate (No Incline, RH Incline)	815 - 1215
44	822-0038-Z	2	3/8" Split Lock Washer (No Incline, RH Incline)	815 - 1215
45	810-5013-Z	4	1/2" Spin Lock Nut (No Incline, RH Incline)	815 - 1215

FRONT FLAT & INCLINE BASE BELT CONVEYOR (CONT'D)

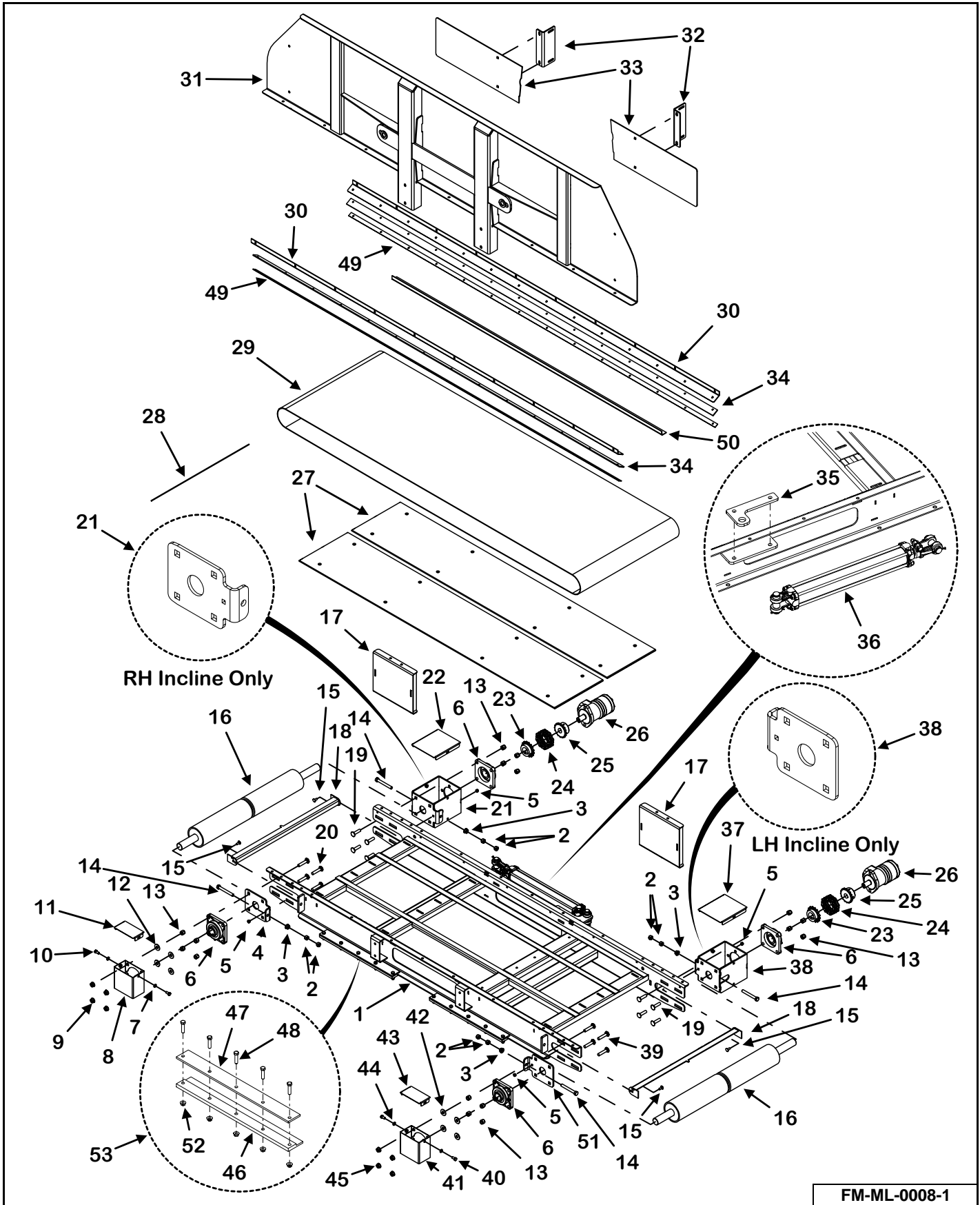

FM-ML-0008-1

KEY	PART NUMBER	QTY	DESCRIPTION	MIXER MODEL
46	VAL-CSK	1	Conveyor Slide Update Kit (Flat Sliding Conveyor Only) Prior to SN 20VM(0815206, 1015208, 1215201)	815 - 1215
	M3-1-8-0053	4	Conveyor Bottom Slide (Flat Sliding Conveyor Only) SN 20VM(0815206, 1015208, 1215201) & Later	815 - 1215
47	VAL-CSK	1	Conveyor Slide Update Kit (Flat Sliding Conveyor Only) Prior to SN 20VM(0815206, 1015208, 1215201)	815 - 1215
	M3-1-8-0052	4	Conveyor Slide Cap (Flat Sliding Conveyor Only) SN 20VM(0815206, 1015208, 1215201) & Later	815 - 1215
48	851-3816-1.5Z	20	3/8"-16 x 1-1/2" Hex Cap Screw	815 - 1215
49	VAL-FCS	1	Skirt Seal Kit (Prior to SN 19VM1015204, 19VM1215209) (Including SN 19VM0815201)	815 - 1215
	M3-1-10-0017-8	2	Front Conveyor Skirt Backer SN 19VM(0815202, 1015204, 1215209) & Later	815 - 1215
50	M3-1-10-0017-4	1	Floor Seal	815 - 1215
51	M3-1-5-0044-1	1	Front Conveyor Bearing Mount	815 - 1215
	See Page 134	1	Bearing Mount Weldment (LH Power Magnet)	815 - 1215
52	810-3816-Z	20	3/8"-16 Spin Lock Nut	815 - 1215
53	VAL-CSK	1	Conveyor Slide Update Kit (Flat Sliding Conveyor Only) Prior to SN 20VM(0815206, 1015208, 1215201)	815 - 1215
	M3-1-8-0053-AS	4	Conveyor Bottom Slide With Cap & Hardware SN 20VM(0815206, 1015208, 1215201) & Later	815 - 1215

FRONT FLAT BELT CONVEYOR HYDRAULIC SCHEMATIC

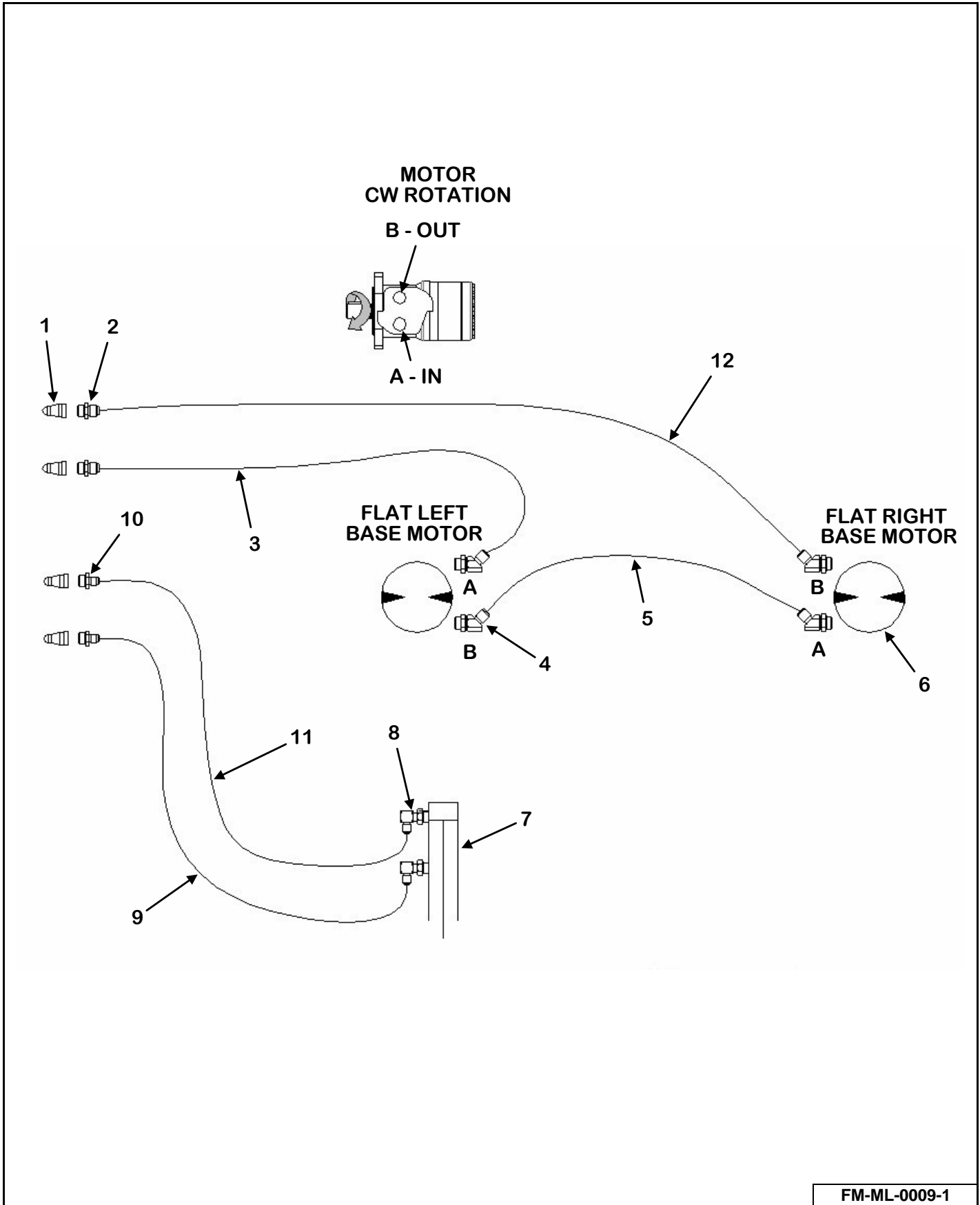

FM-ML-0009-1

KEY	PART NUMBER	QTY	DESCRIPTION	MIXER MODEL
1	155-8010-15	4	#8 ORB Male Tip 1/2" Body Size	815 - 1215
2	155-6400-8-8	2	#8 JIC Male, #8 ORB Male Straight Connector	815 - 1215
3	155-08R17-208-1	1	1/2" x 208" Hose Assembly (Stop & Shift Models)	815 - 1215
	155-08R17-248-1	1	1/2" x 248" Hose Assembly (Power Shift Models)	815 - 1215
4	155-6802-8-10	4	#8 JIC Male, #10 ORB Male Adjustable 45°	815 - 1215
5	155-08R17-189-1	1	1/2" x 189" Hose Assembly	815 - 1215
6	155-WR-12.1-1	2	12.1 Cubic Inch 2-Bolt Motor	815 - 1215
	155-WR-SK-1	AR	Motor Seal Kit	815 - 1215
7	155-2-16-1.125-2	1	2" x 16" x 1-1/8" Hydraulic Cylinder, Modified Port	815 - 1215
	155-2-1.125-1-DSK	1	Cylinder Seal Kit	815 - 1215
8	155-6801-6-8	2	#6 JIC Male, #8 ORB Male Adjustable 90°	815 - 1215
9	155-04R17-197-1	1	1/4" x 197" Hose Assembly (Single Axle & LH Discharge Tandem Axle Trailers) (Stop & Shift Models)	815 - 1215
	155-04R17-218-1	1	1/4" x 218" Hose Assembly (RH Discharge Tandem Axle Trailer) (Stop & Shift Models)	815 - 1215
	155-04R17-227-1	1	1/4" x 227" Hose Assembly (Power Shift Models)	815 - 1215
10	155-6400-6-8	2	#6 JIC Male, #8 ORB Male Straight Connector	815 - 1215
11	155-04R17-197-1	1	1/4" x 197" Hose Assembly (Single Axle & LH Discharge Tandem Axle Trailers) (Stop & Shift Models)	815 - 1215
	155-04R17-233-1	1	1/4" x 233" Hose Assembly (RH Discharge Tandem Axle Trailer) (Stop & Shift Models)	815 - 1215
	155-04R17-227-1	1	1/4" x 227" Hose Assembly (Power Shift Models)	815 - 1215
12	155-08R17-208-1	1	1/2" x 208" Hose Assembly (Stop & Shift Models)	815 - 1215
	155-08R17-248-1	1	1/2" x 248" Hose Assembly (Power Shift Models)	815 - 1215

FRONT INCLINE BELT CONVEYOR

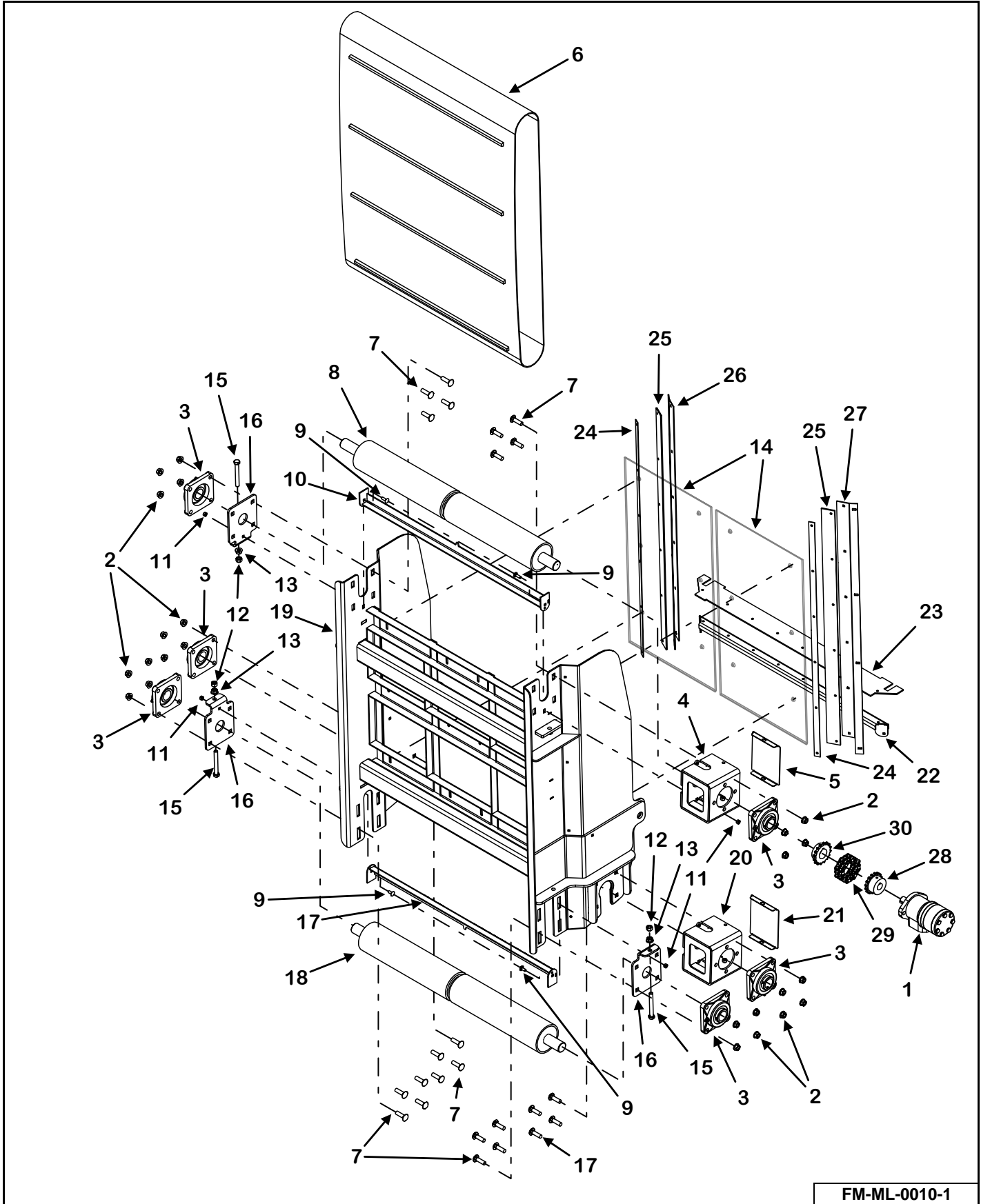

FM-ML-0010-1

KEY	PART NUMBER	QTY	DESCRIPTION	MIXER MODEL
0	VAL-FDB-LI36K	1	36" Front LH Belt Conveyor, Incline Section Only Kit	815 - 1215
	VAL-FDB-RI36K	1	36" Front RH Belt Conveyor, Incline Section Only Kit	815 - 1215
	VAL-FDB-LI48K	1	48" Front LH Belt Conveyor, Incline Section Only Kit	815 - 1215
	VAL-FDB-RI48K	1	48" Front RH Belt Conveyor, Incline Section Only Kit	815 - 1215
	VAL-FDB-LI60K	1	60" Front LH Belt Conveyor, Incline Section Only Kit	815 - 1215
	VAL-FDB-RI60K	1	60" Front RH Belt Conveyor, Incline Section Only Kit	815 - 1215
	VAL-FDB-LI72K	1	72" Front LH Belt Conveyor, Incline Section Only Kit	815 - 1215
	VAL-FDB-RI72K	1	72" Front RH Belt Conveyor, Incline Section Only Kit	815 - 1215
1	See Page 126	1	7.9 Cubic Inch 2-Bolt Motor	815 - 1215
	135-2525-1.25-1	1	Key	815 - 1215
2	810-5013-Z	24	1/2" Spin Lock Nut	815 - 1215
3	14-0070	6	1-1/2" 4-Bolt Bearing Narrow Inner Race	815 - 1215
4	M3-1-5-0049	1	Conveyor Motor Mount Weldment	815 - 1215
5	M3-1-8-0006	1	Coupler Cover Plate	815 - 1215
	851-3816-.75Z	2	3/8"-16 x 3/4" Machine Bolt	815 - 1215
	822-0038-Z	2	3/8" Split Lock Washer	815 - 1215
6	49-0232-MB	1	24" Incline Mini Bite Belt	815 - 1215
	49-0168-MB	1	36" Incline Mini Bite Belt	815 - 1215
	49-0195-MB	1	48" Incline Mini Bite Belt	815 - 1215
	49-0196-MB	1	60" Incline Mini Bite Belt	815 - 1215
	49-0216-MB	1	72" Incline Mini Bite Belt	815 - 1215
	49-0156-6-AS	1	Conveyor Belt Lacing Pin Kit	815 - 1215
7	850-5013-1.75Z	20	1/2"-13 x 1-3/4" Carriage Bolt	815 - 1215
8	23-0251	1	Drive Pulley Urethane Lagged	815 - 1215
9	850-3118-1Z	4	5/16"-18 x 1" Carriage Bolt	815 - 1215
10	M3-1-10-0023	2	Conveyor Pulley Scraper	815 - 1215
11	814-3118-Z	4	5/16"-18 Indented Lock Nut	815 - 1215
12	813-5013-Z	3	1/2"-13 Nut	815 - 1215
13	810-5013-Z	3	1/2" Spin Lock Nut	815 - 1215

FRONT INCLINE BELT CONVEYOR (CONT'D)

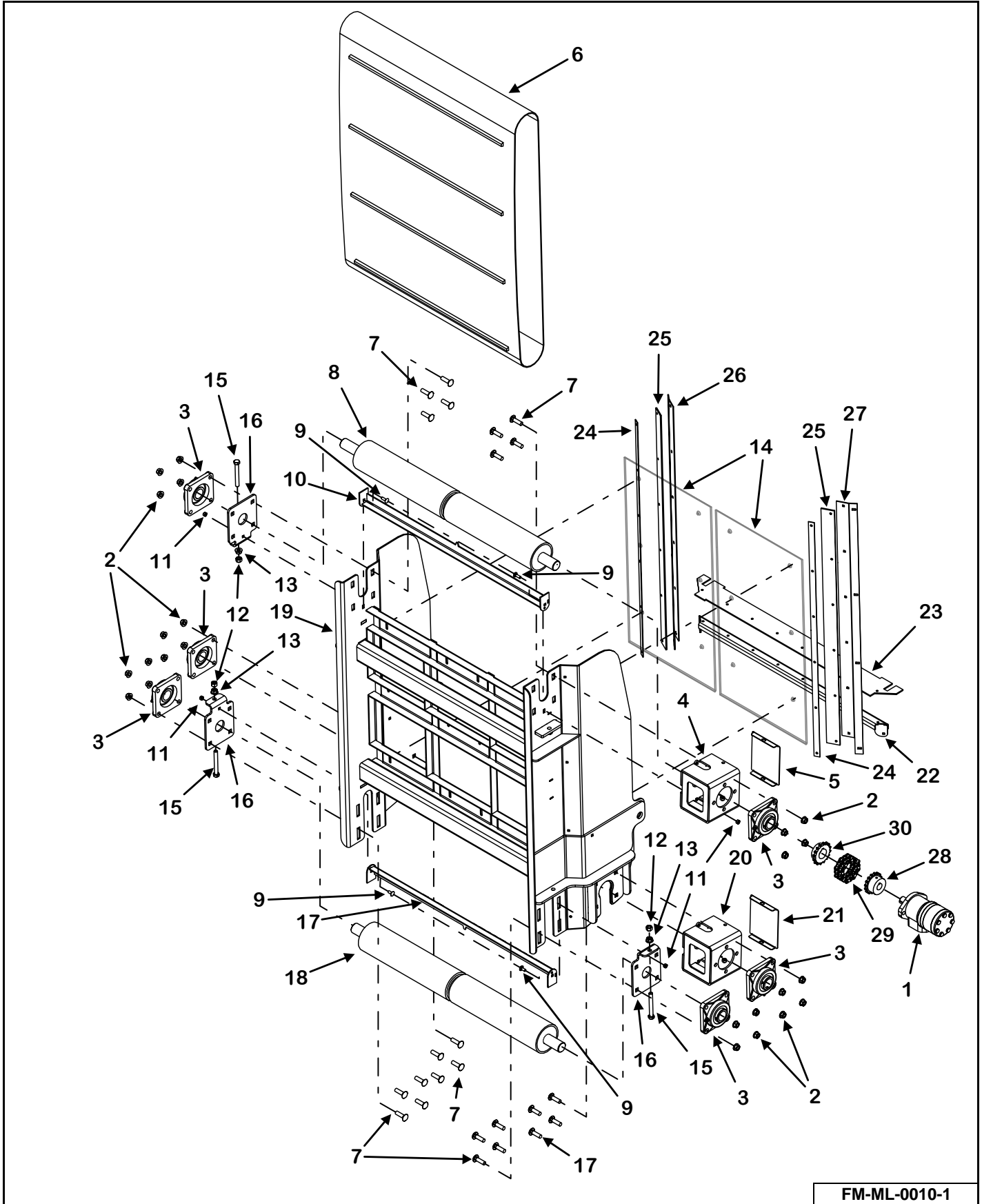

FM-ML-0010-1

KEY	PART NUMBER	QTY	DESCRIPTION	MIXER MODEL
14	M3-1-4-0075	2	24" Incline Floor	815 - 1215
	M3-1-4-0036	2	36" Incline Floor	815 - 1215
	M3-1-4-0048	2	36" Incline Floor	815 - 1215
	M3-1-4-0052	2	60" Incline Floor	815 - 1215
	M3-1-4-0058	2	72" Incline Floor	815 - 1215
15	830-5013-4Z	3	1/2"-13 x 4" Tap Bolt Full Threaded	815 - 1215
16	M3-1-5-0044-1	3	Front Conveyor Bearing Mount	815 - 1215
17	850-5013-2Z	4	1/2"-13 x 2" Carriage Bolt	815 - 1215
18	23-0257	1	Idler Pulley	815 - 1215
19	M3-1-5-0063-1	1	24" Front Incline Belt Conveyor, Incline Frame Weldment	815 - 1215
	M3-1-5-0041-1	1	36" Front Incline Belt Conveyor, Incline Frame Weldment	815 - 1215
	M3-1-5-0051-1	1	48" Front Incline Belt Conveyor, Incline Frame Weldment	815 - 1215
	M3-1-5-0064-1	1	60" Front Incline Belt Conveyor, Incline Frame Weldment	815 - 1215
	M3-1-5-0065-1	1	72" Front Incline Belt Conveyor, Incline Frame Weldment	815 - 1215
20	M3-1-8-0034	1	Conveyor Motor Mount Weldment	815 - 1215
21	M3-1-8-0006	1	Coupler Cover Plate	815 - 1215
22	M3-1-5-0041-3	1	Incline Belt Conveyor Seal Weldment	815 - 1215
23	49-0241	1	Incline Belt Conveyor Seal	815 - 1215
24	VA-ICS-24	1	24" Incline Skirt Seal Kit Prior to SN 19VM(0815202, 1015204, 1215209)	815 - 1215
	M3-1-5-0063-8	2	24" Incline Skirt Backer SN 19VM(0815202, 1015204, 1215209) & Later	815 - 1215
	VA-ICS-36	1	36" Incline Skirt Seal Kit Prior to SN 19VM(0815201, 1015204, 1215209)	815 - 1215
	M3-1-5-0041-10	2	36" Incline Skirt Backer SN 19VM(0815202, 1015204, 1215209) & Later	815 - 1215
	VA-ICS-48	1	48" Incline Skirt Seal Kit Prior to SN 19VM(0815201, 1015204, 1215209)	815 - 1215
	M3-1-5-0051-8	2	48" Incline Skirt Backer SN 19VM(0815202, 1015204, 1215209) & Later	815 - 1215
	VA-ICS-60	1	60" Incline Skirt Seal Kit Prior to SN 19VM(0815201, 1015204, 1215209)	815 - 1215
	M3-1-5-0064-9	2	60" Incline Skirt Backer SN 19VM(0815202, 1015204, 1215209) & Later	815 - 1215
	VA-ICS-72	1	72" Incline Skirt Seal Kit Prior to SN 19VM(0815201, 1015204, 1215209)	815 - 1215
	M3-1-5-0065-8	2	72" Incline Skirt Backer SN 19VM(0815202, 1015204, 1215209) & Later	815 - 1215

FRONT INCLINE BELT CONVEYOR (CONT'D)

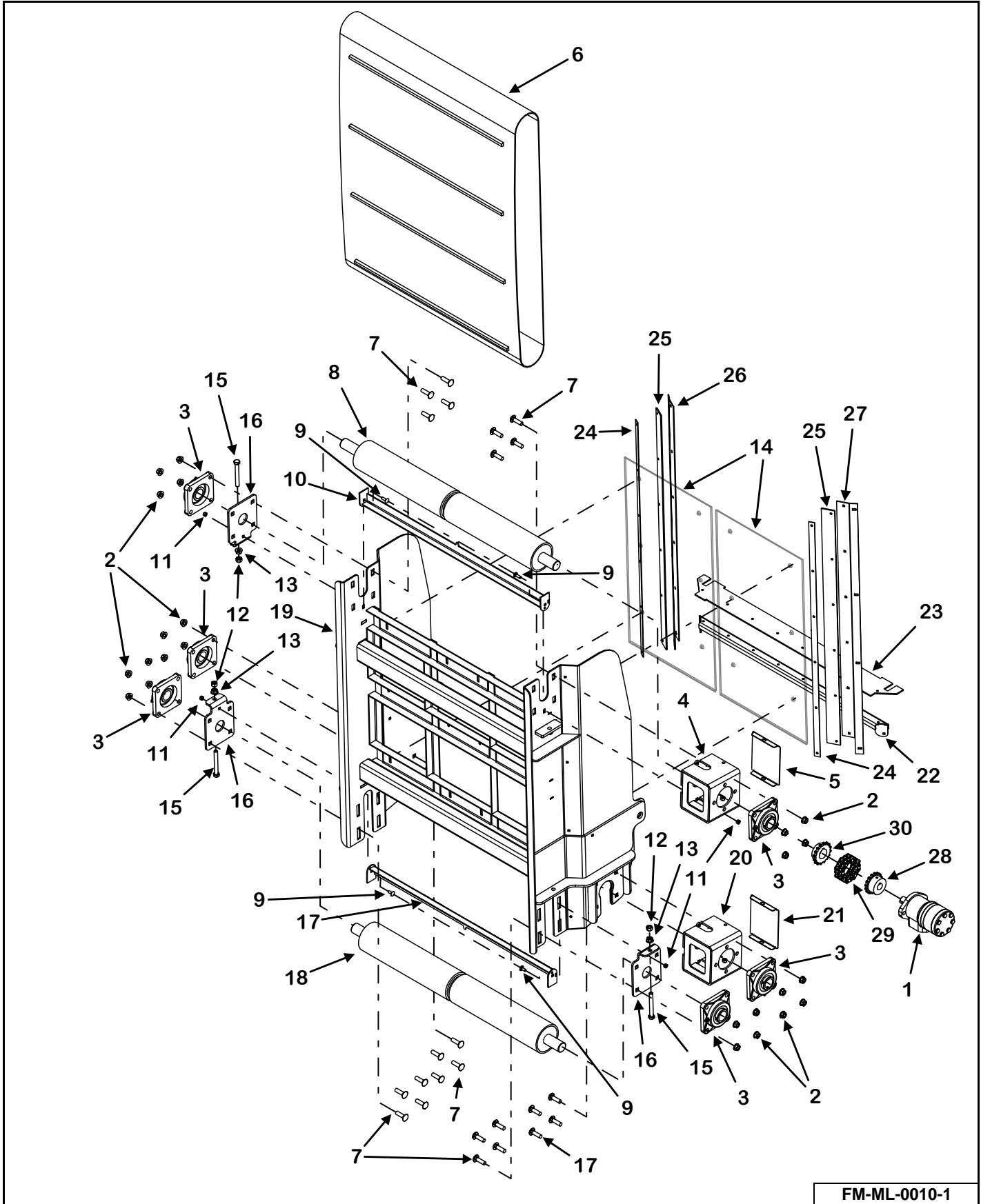

FM-ML-0010-1

KEY	PART NUMBER	QTY	DESCRIPTION	MIXER MODEL
25	VA-ICS-24	1	24" Incline Skirt Seal Kit Prior to SN 19VM(0815202, 1015204, 1215209)	815 - 1215
	49-0350	2	24" Incline Side Skirting SN 19VM(0815202, 1015204, 1215209) & Later	815 - 1215
	VA-ICS-36	1	36" Incline Skirt Seal Kit Prior to SN 19VM(0815201, 1015204, 1215209)	815 - 1215
	49-0348	2	36" Incline Side Skirting SN 19VM(0815202, 1015204, 1215209) & Later	815 - 1215
	VA-ICS-48	1	48" Incline Skirt Seal Kit Prior to SN 19VM(0815201, 1015204, 1215209)	815 - 1215
	49-0346	2	48" Incline Side Skirting SN 19VM(0815202, 1015204, 1215209) & Later	815 - 1215
	VA-ICS-60	1	60" Incline Skirt Seal Kit Prior to SN 19VM(0815201, 1015204, 1215209)	815 - 1215
	49-0344	2	60" Incline Side Skirting SN 19VM(0815202, 1015204, 1215209) & Later	815 - 1215
	VA-ICS-72	1	72" Incline Skirt Seal Kit Prior to SN 19VM(0815201, 1015204, 1215209)	815 - 1215
	49-0342	2	72" Incline Side Skirting SN 19VM(0815202, 1015204, 1215209) & Later	815 - 1215
26	VA-ICS-24	1	24" Incline Skirt Seal Kit Prior to SN 19VM(0815202, 1015204, 1215209)	815 - 1215
	M3-1-5-0063-7	1	24" Incline Side Skirt Bracket SN 19VM(0815202, 1015204, 1215209) & Later	815 - 1215
	VA-ICS-36	1	36" Incline Skirt Seal Kit Prior to SN 19VM(0815201, 1015204, 1215209)	815 - 1215
	M3-1-5-0041-9	1	36" Incline Side Skirt Bracket SN 19VM(0815202, 1015204, 1215209) & Later	815 - 1215
	VA-ICS-48	1	48" Incline Skirt Seal Kit Prior to SN 19VM(0815201, 1015204, 1215209)	815 - 1215
	M3-1-5-0051-7	1	48" Incline Side Skirt Bracket SN 19VM(0815202, 1015204, 1215209) & Later	815 - 1215
	VA-ICS-60	1	60" Incline Skirt Seal Kit Prior to SN 19VM(0815201, 1015204, 1215209)	815 - 1215
	M3-1-5-0064-8	1	60" Incline Side Skirt Bracket SN 19VM(0815202, 1015204, 1215209) & Later	815 - 1215
	VA-ICS-72	1	72" Incline Skirt Seal Kit Prior to SN 19VM(0815201, 1015204, 1215209)	815 - 1215
	M3-1-5-0065-7	1	72" Incline Side Skirt Bracket SN 19VM(0815202, 1015204, 1215209) & Later	815 - 1215

FRONT INCLINE BELT CONVEYOR (CONT'D)

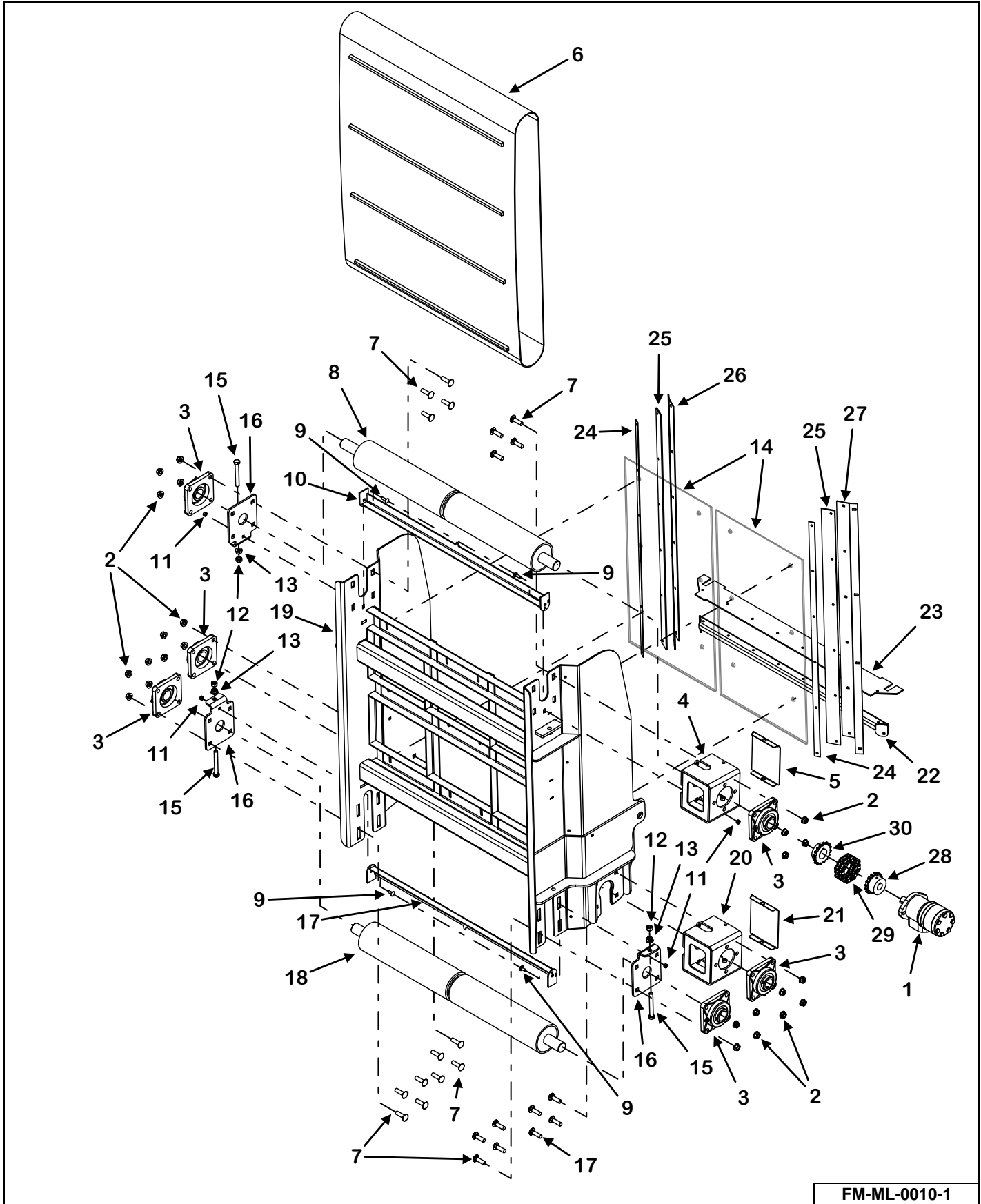

FM-ML-0010-1

KEY	PART NUMBER	QTY	DESCRIPTION	MIXER MODEL
27	VA-ICS-24	1	24" Incline Skirt Seal Kit Prior to SN 19VM(0815202, 1015204, 1215209)	815 - 1215
	M3-1-5-0063-6	1	24" Incline Side Skirt Bracket SN 19VM(0815202, 1015204, 1215209) & Later	815 - 1215
	VA-ICS-36	1	36" Incline Skirt Seal Kit Prior to SN 19VM(0815201, 1015204, 1215209)	815 - 1215
	M3-1-5-0041-8	1	36" Incline Side Skirt Bracket SN 19VM(0815202, 1015204, 1215209) & Later	815 - 1215
	VA-ICS-48	1	48" Incline Skirt Seal Kit Prior to SN 19VM(0815201, 1015204, 1215209)	815 - 1215
	M3-1-5-0051-6	1	48" Incline Side Skirt Bracket SN 19VM(0815202, 1015204, 1215209) & Later	815 - 1215
	VA-ICS-60	1	60" Incline Skirt Seal Kit Prior to SN 19VM(0815201, 1015204, 1215209)	815 - 1215
	M3-1-5-0064-7	1	60" Incline Side Skirt Bracket SN 19VM(0815202, 1015204, 1215209) & Later	815 - 1215
	VA-ICS-72	1	72" Incline Skirt Seal Kit Prior to SN 19VM(0815201, 1015204, 1215209)	815 - 1215
	M3-1-5-0065-6	1	72" Incline Side Skirt Bracket SN 19VM(0815202, 1015204, 1215209) & Later	815 - 1215
28	37-0013-1	1	Coupler Sprocket	815 - 1215
29	37-0013-2	1	Coupler Chain	815 - 1215
30	110-50B16-1.50-1	1	Coupler Sprocket	815 - 1215
	35-0006	1	Key	815 - 1215

FRONT LH INCLINE BELT CONVEYOR HYDRAULIC SCHEMATIC

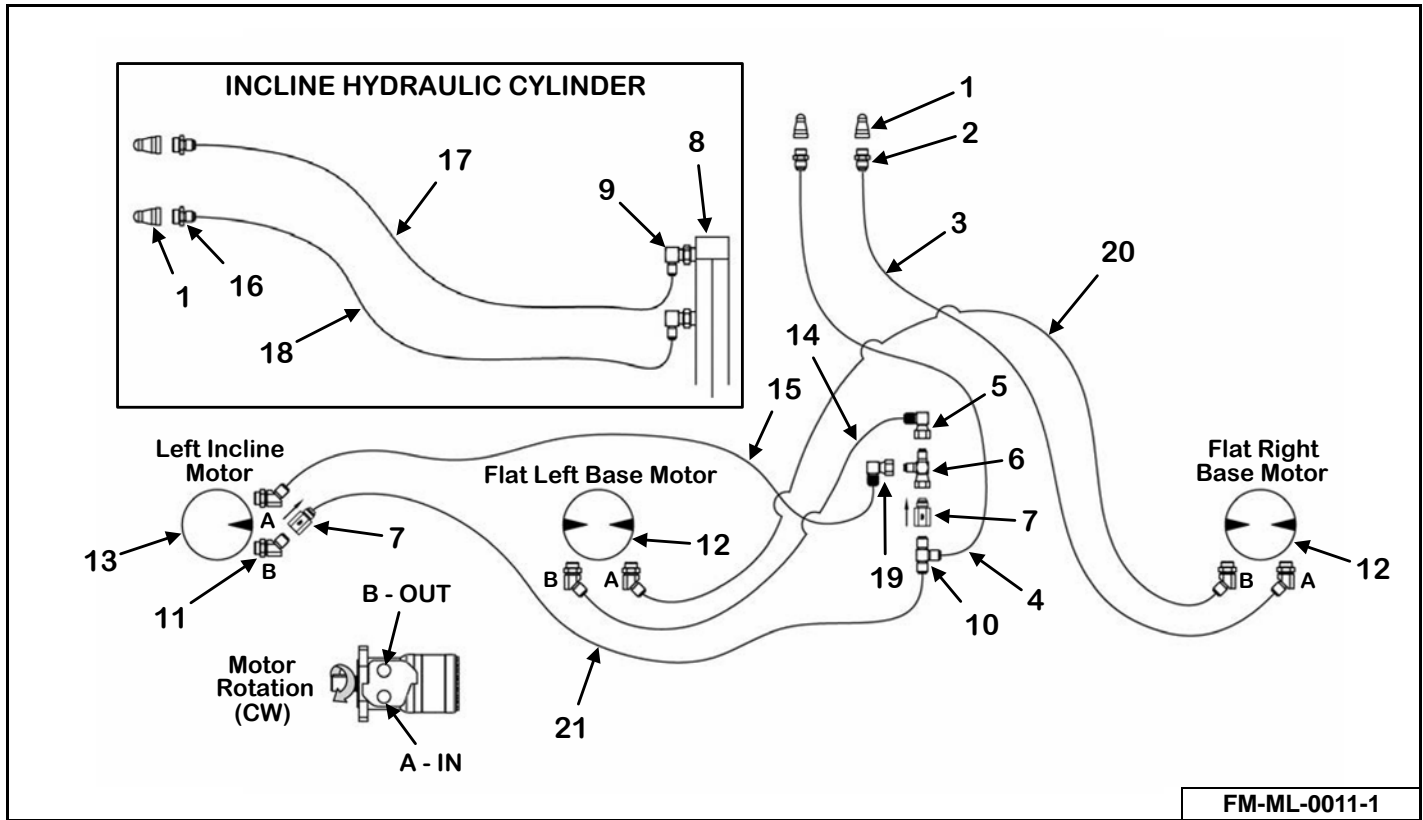

FRONT RH INCLINE BELT CONVEYOR HYDRAULIC SCHEMATIC

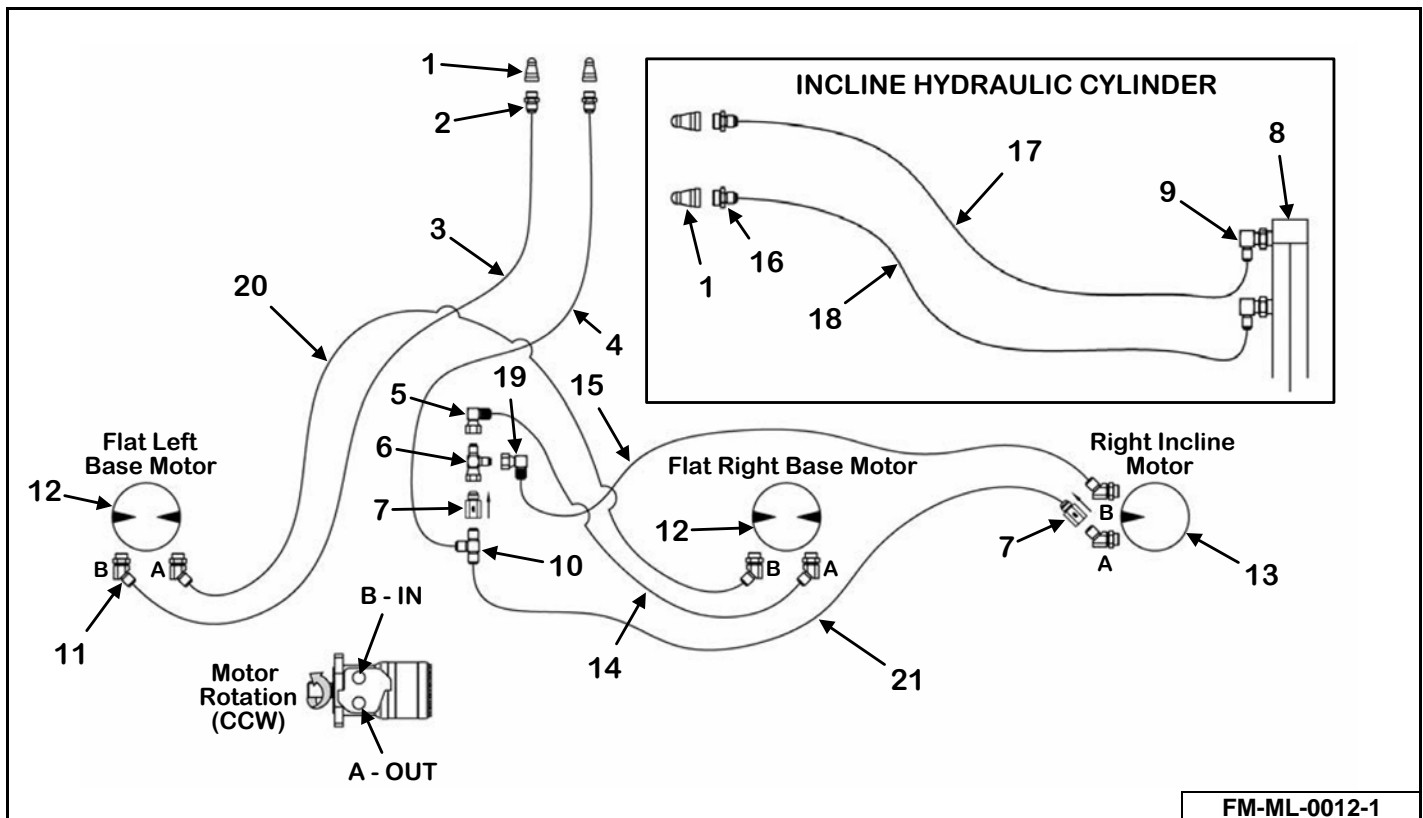

KEY	PART NUMBER	QTY	DESCRIPTION	MIXER MODEL
1	155-8010-15	4	#8 ORB Male Tip 1/2" Body Size	815 - 1215
2	155-6400-8-8	2	#8 JIC Male, #8 ORB Male Straight Connector	815 - 1215
3	155-08R17-208-1	1	1/2" x 208" Hose Assembly	815 - 1215
4	155-08R17-133-1	1	1/2" x 133" Hose Assembly	815 - 1215
5	155-6500-08-08	1	#8 JIC Male, #8 JIC Female Swivel 90°	815 - 1215
6	155-6602-08-08-08	1	#8 MJ x #8 FJS x #8 MJ Tee	815 - 1215
7	155-CV-8-1	2	Check Valve	815 - 1215
8	155-2-16-1.125-1	1	2" x 16" x 1-1/8" Hydraulic Cylinder	815 - 1215
	155-2-1.125-1-DSK	1	Cylinder Seal Kit	815 - 1215
9	155-6801-6-8-55	2	#6 x #8 90° Adjustable Elbow with 0.055" Orifice	815 - 1215
10	155-2603-08-08-08	1	#8 x #8 x #8 JIC Male Tube Tee	815 - 1215
11	155-6802-8-10	6	#8 JIC Male, #10 ORB Male Adjustable 45°	815 - 1215
12	155-WR-12.1-1	2	12.1 Cubic Inch 2-Bolt Motor	815 - 1215
	155-WR-SK-1	AR	Motor Seal Kit	815 - 1215
13	155-WR-7.9-1	1	7.9 Cubic Inch 2-Bolt Motor	815 - 1215
	155-WR-SK-1	AR	Motor Seal Kit	815 - 1215
14	155-08R17-81-1	1	1/2" x 81" Hose Assembly	815 - 1215
15	155-08R17-117-1	1	1/2" x 117" Hose Assembly (36" Incline)	815 - 1215
	155-08R17-129-1	1	1/2" x 129" Hose Assembly (48" Incline)	815 - 1215
	155-08R17-141-1	1	1/2" x 141" Hose Assembly (60" Incline)	815 - 1215
	155-08R17-153-1	1	1/2" x 153" Hose Assembly (72" Incline)	815 - 1215
16	155-6400-6-8	2	#6 x JIC Male Tube #8 ORB Male Straight Connector	815 - 1215
17	155-04R17-121-1	1	1/4" x 121" Hose Assembly	815 - 1215
18	155-04R17-102-1	1	1/4" x 102" Hose Assembly	815 - 1215
19	155-6500-08-08	1	#8 JIC Male, #8 JIC Female Swivel 90°	815 - 1215
20	155-08R17-189-1	1	1/2" x 189" Hose Assembly	815 - 1215
21	155-08R17-117-1	1	1/2" x 117" Hose Assembly (36" Incline)	815 - 1215
	155-08R17-129-1	1	1/2" x 129" Hose Assembly (48" Incline)	815 - 1215
	155-08R17-141-1	1	1/2" x 141" Hose Assembly (60" Incline)	815 - 1215
	155-08R17-153-1	1	1/2" x 153" Hose Assembly (72" Incline)	815 - 1215

FRONT INCLINE BELT CONVEYOR STOP

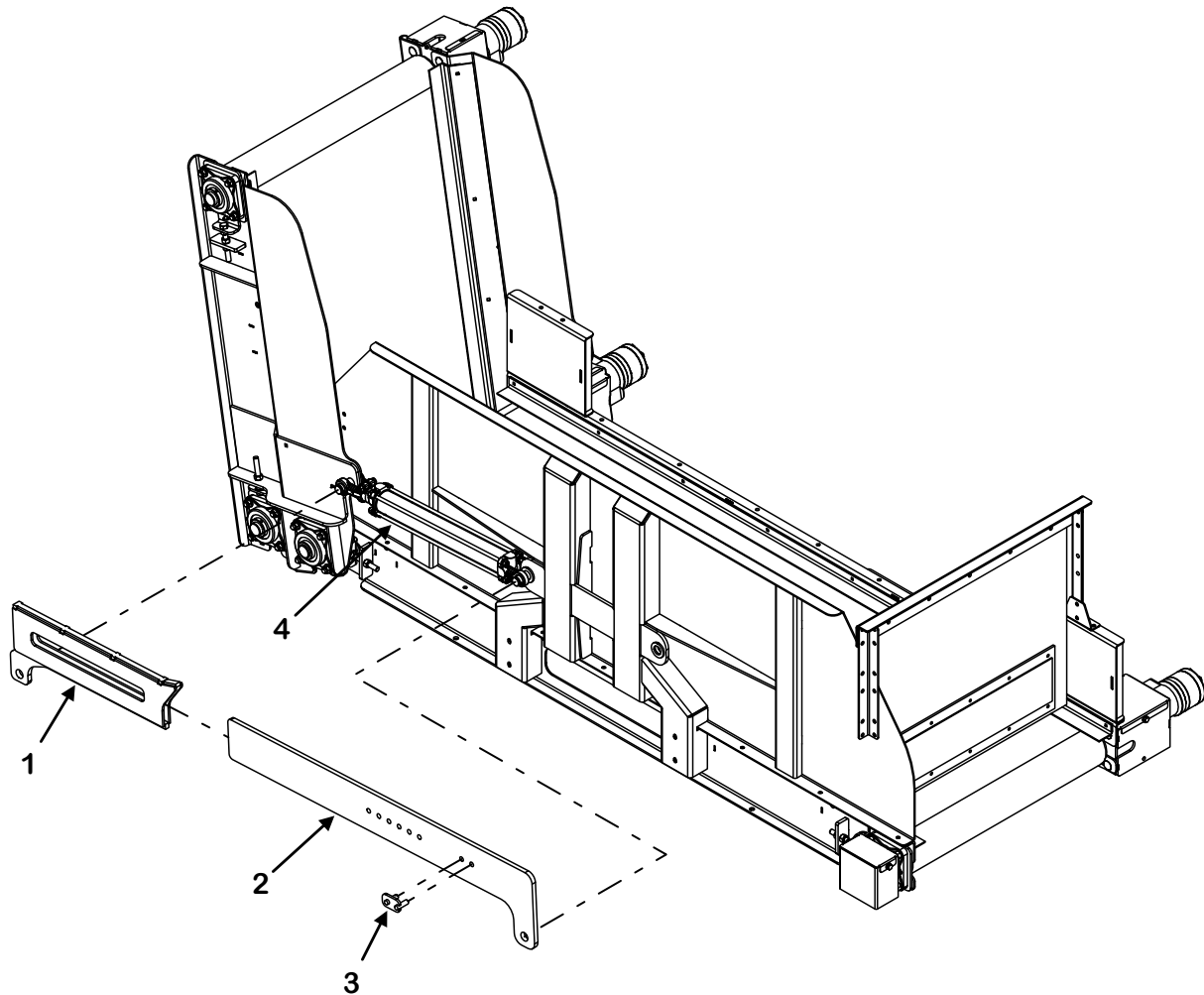

FM-ML-0013-1

KEY	PART NUMBER	QTY	DESCRIPTION	MIXER MODEL
0	VA-IBCS	1	Incline Belt Conveyor Stop	815 - 1215
1	M3-1-5-0070	1	Incline Conveyor Stop Slider Weldment	815 - 1215
2	M3-1-5-0052	1	Incline Conveyor Stop Bar	815 - 1215
3	M3-1-5-0055	1	Belt Conveyor Stop Weldment	815 - 1215
	32-0019	1	Hair Spring Cotter Pin	815 - 1215
4	See Page 126	1	2" x 16" x 1-1/8" Hydraulic Cylinder	815 - 1215

FRONT FLAT & INCLINE CHAIN CONVEYOR ASSEMBLY

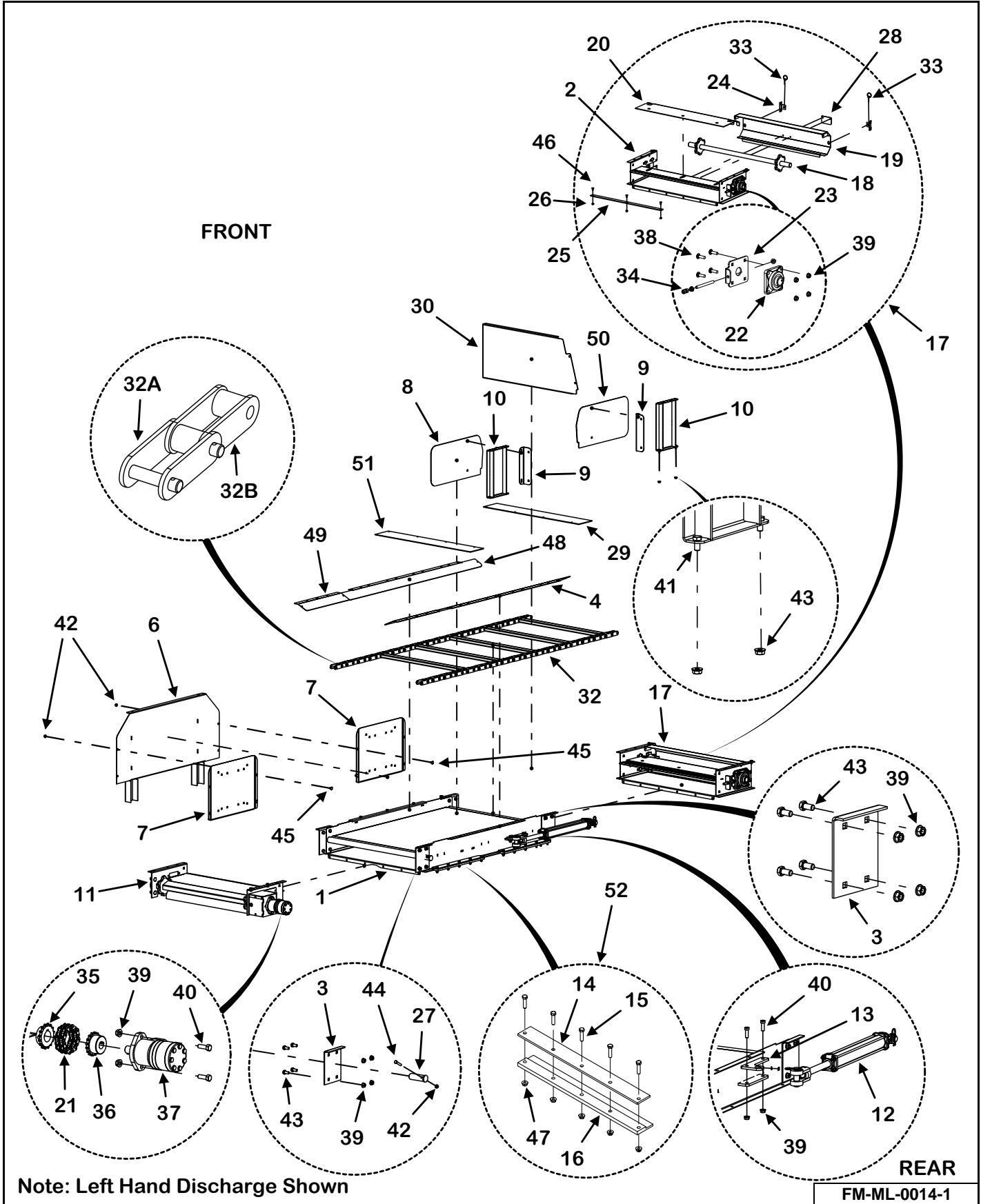

Note: Left Hand Discharge Shown

FM-ML-0014-1

KEY	PART NUMBER	QTY	DESCRIPTION	MIXER MODEL
1	M3-1-10-0003	1	Front Conveyor-Center Section Weldment, Flat	815 - 1215
2	M3-1-5-0002-1	1	Front Conveyor Panel Weldment	815 - 1215
3	M3-1-7-0014	4	Front Conveyor Connecting Plate	815 - 1215
4	M3-1-10-0005	1	Conveyor Chain Cover, Flat (LH Discharge-Rear, RH Discharge-Front)	815 - 1215
5	M3-1-5-0012	1	Conveyor Chain Cover, Flat (LH Discharge-Rear, RH Discharge-Front)	815 - 1215
6	M3-1-10-0004	1	Front Conveyor Panel Weldment	815 - 1215
7	M3-1-5-0010	2	Front Conveyor Panel	815 - 1215
8	M3-1-10-0009	1	Front Conveyor Shield, Flat	815 - 1215
	M3-1-8-0029	1	Front Conveyor Shield, Incline (Left Discharge)	815 - 1215
	M3-1-10-0007	1	Front Conveyor Shield, Incline (Right Discharge)	815 - 1215
9	M3-1-8-0028	2	Front Shield Mounting Bracket	815 - 1215
10	M3-1-10-0010	2	Conveyor Shield Assembly	815 - 1215
11	See Page 134	1	Front Flat & Incline Conveyor Assembly	815 - 1215
12	See Page 136	1	Hydraulic Cylinder	815 - 1215
	33-0309	1	Cylinder Pin Spacer, Flat & Incline	815 - 1215
13	M3-1-8-0027	1	Front Conveyor Cylinder Mount	815 - 1215
14	VAL-CSK	1	Conveyor Slide Update Kit (Flat Sliding Conveyor Only) Prior to SN 20VM(0815206, 1015208, 1215201)	815 - 1215
	M3-1-8-0052	4	Conveyor Slide Cap (Flat Sliding Conveyor Only) SN 20VM(0815206, 1015208, 1215201) & Later	815 - 1215
15	851-3816-1.5Z	20	3/8"-16 x 1-1/2" Hex Cap Screw	815 - 1215
16	VAL-CSK	1	Conveyor Slide Update Kit (Flat Sliding Conveyor Only) Prior to SN 20VM(0815206, 1015208, 1215201)	815 - 1215
	M3-1-8-0053	4	Conveyor Bottom Slide (Flat Sliding Conveyor Only) SN 20VM(0815206, 1015208, 1215201) & Later	815 - 1215
17	M3-1-5-0002	1	Front Conveyor Extension Assembly	815 - 1215
18	23-0255	1	Conveyor Idler Shaft Assembly	815 - 1215
19	M3-1-7-0005-1-AS	1	Conveyor Extension Chain Guard	815 - 1215
20	M3-1-7-0013	1	Extension Sprocket Cover	815 - 1215
21	37-0013-2	1	Unit Coupler Chain #50 16 Double W/Connector	815 - 1215
22	14-0070	4	1-1/2" 4 Bolt Bearing	815 - 1215
23	M3-1-8-0002	2	Front Conveyor Bearing Mount	815 - 1215
24	M3-1-7-0034	2	Conveyor Extension Cover Latch	815 - 1215
25	M3-1-4-0029	1	36" Extension Adjustment Bracket Weldment	815 - 1215
26	813-3118	3	5/16"-18 Hex Nut Plain	815 - 1215
27	M3-1-5-0004-2	2	Hinge Pin, Incline	815 - 1215
28	M3-1-7-0005-2	1	Conveyor Extension Cover Handle	815 - 1215
29	49-0184	1	Front Left Discharge Conveyor Chain Cover, Incline	815 - 1215

FRONT FLAT & INCLINE CHAIN CONVEYOR ASSEMBLY (CONT'D)

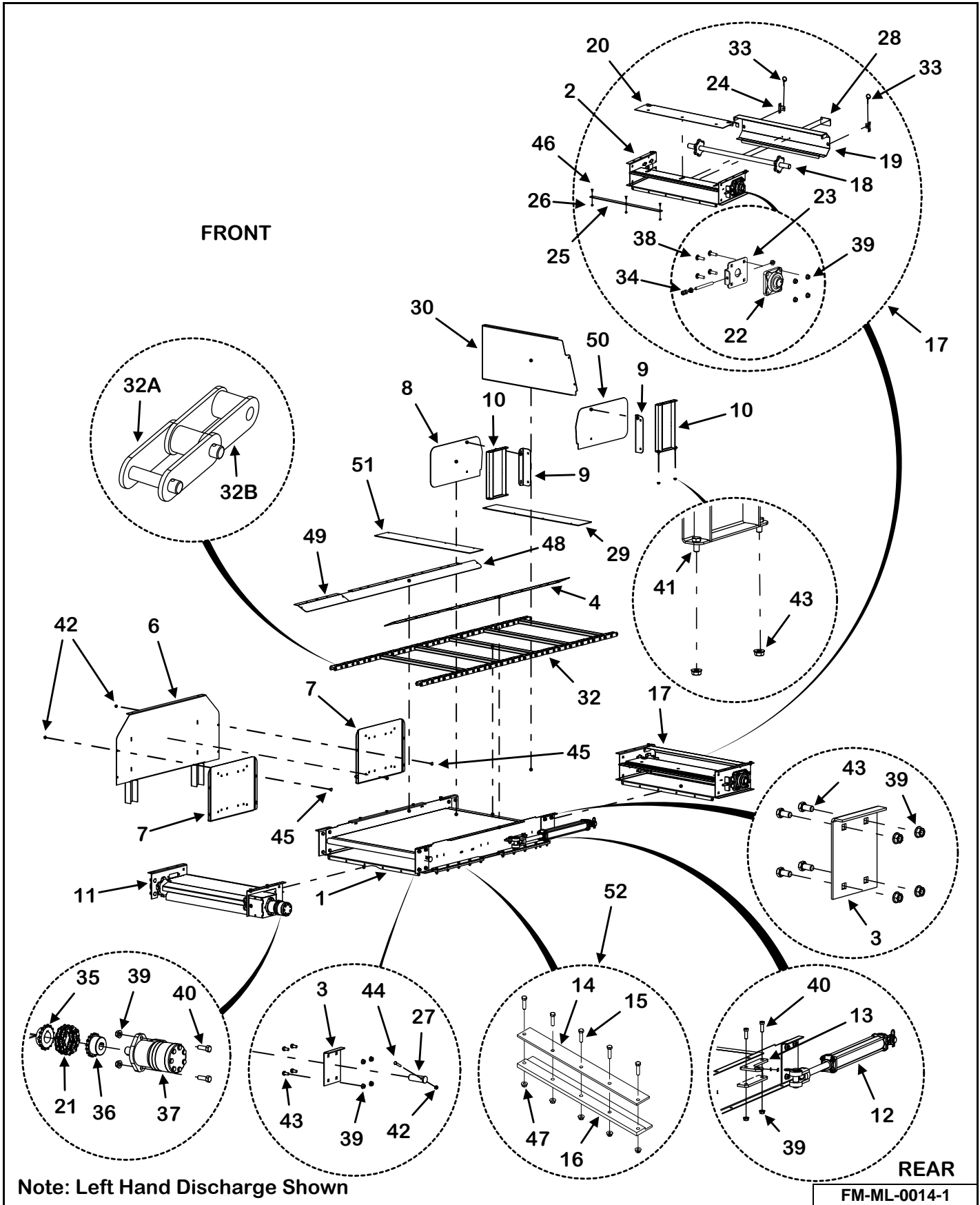

KEY	PART NUMBER	QTY	DESCRIPTION	MIXER MODEL
30	M3-1-10-0001	1	Conveyor Cross Panel – Incline	815 - 1215
31	830-5013-4Z	2	Tap Bolt, 1/2”-13 x 4”	815 - 1215
32	11-0506	1	Front Discharge, 36” Flat Conveyor 81x Chain	815 - 1215
32A	11-0272-4	AR	81X Connector Link	815 - 1215
32B	11-0272-5	AR	81X Offset Link	815 - 1215
33	823-0003	2	Lynch Pin 3/16” x 1-1/4”	815 - 1215
34	813-5013-Z	4	1/2”-13 Nut	815 - 1215
35	110-50B16-1.50-1	1	Chain Coupler Sprocket 1.5 Bore x .375” Keyway	815 - 1215
36	37-0013-1	1	Unit Coupler 1” Bore 1/4” Keyway	815 - 1215
	135-2525-1.25-1	1	1/4” x 1/4” x 1-1/4” Key	815 - 1215
37	See Page 136	1	12.1 Cubic Inch 2-Bolt Motor	815 - 1215
38	850-5013-1.75Z	16	1/2”-13 x 1-3/4” Carriage Bolt, Grade 5	815 - 1215
39	810-5013-Z	28	1/2” Spin Lock Nut	815 - 1215
40	851-5013-1.5Z	4	1/2”-13 x 1-1/2” Bolt	815 - 1215
41	851-3816-.75Z	4	3/8”-16 x 3/4” Grade 5 Machine Bolt	815 - 1215
42	810-3816-Z	10	3/8” Spin Lock Nut	815 - 1215
43	851-5013-1Z	16	1/2”-13 x 1” Bolt	815 - 1215
44	851-3816-2Z	2	3/8”-16 x 2” Grade 5 Machine Bolt	815 - 1215
45	850-3816-.75Z	4	3/8”-16 x 3/4” Grade 5 Carriage Bolt	815 - 1215
46	803-3118-.75Z	3	5/16”-18 x 3/4” Flat Head Socket Cap Screw	815 - 1215
47	810-3816-Z	20	3/8”-16 Spin Lock Nut	815 - 1215
48	M3-1-10-0011	1	Conveyor Chain Cover, Flat (LH Discharge-Front, RH Discharge-Rear)	815 - 1215
49	M3-1-5-0029	1	Conveyor Chain Cover, Flat Extension (LH Discharge- Front, RH Discharge-Rear)	815 - 1215
50	M3-1-10-0008	1	Front Conveyor Shield, Flat	815 - 1215
	M3-1-8-0030	1	Front Conveyor Shield, Incline (Right Discharge)	815 - 1215
	M3-1-10-0006	1	Front Conveyor Shield, Incline (Left Discharge)	815 - 1215
51	49-0185	1	Front Right Discharge Conveyor Chain Cover, Incline	815 - 1215
52	VAL-CSK	1	Conveyor Slide Update Kit (Flat Sliding Conveyor Only) Prior to SN 20VM(0815206, 1015208, 1215201)	815 - 1215
	M3-1-8-0053-AS	4	Conveyor Bottom Slide With Cap & Hardware SN 20VM(0815206, 1015208, 1215201) & Later	815 - 1215

FRONT FLAT CONVEYOR

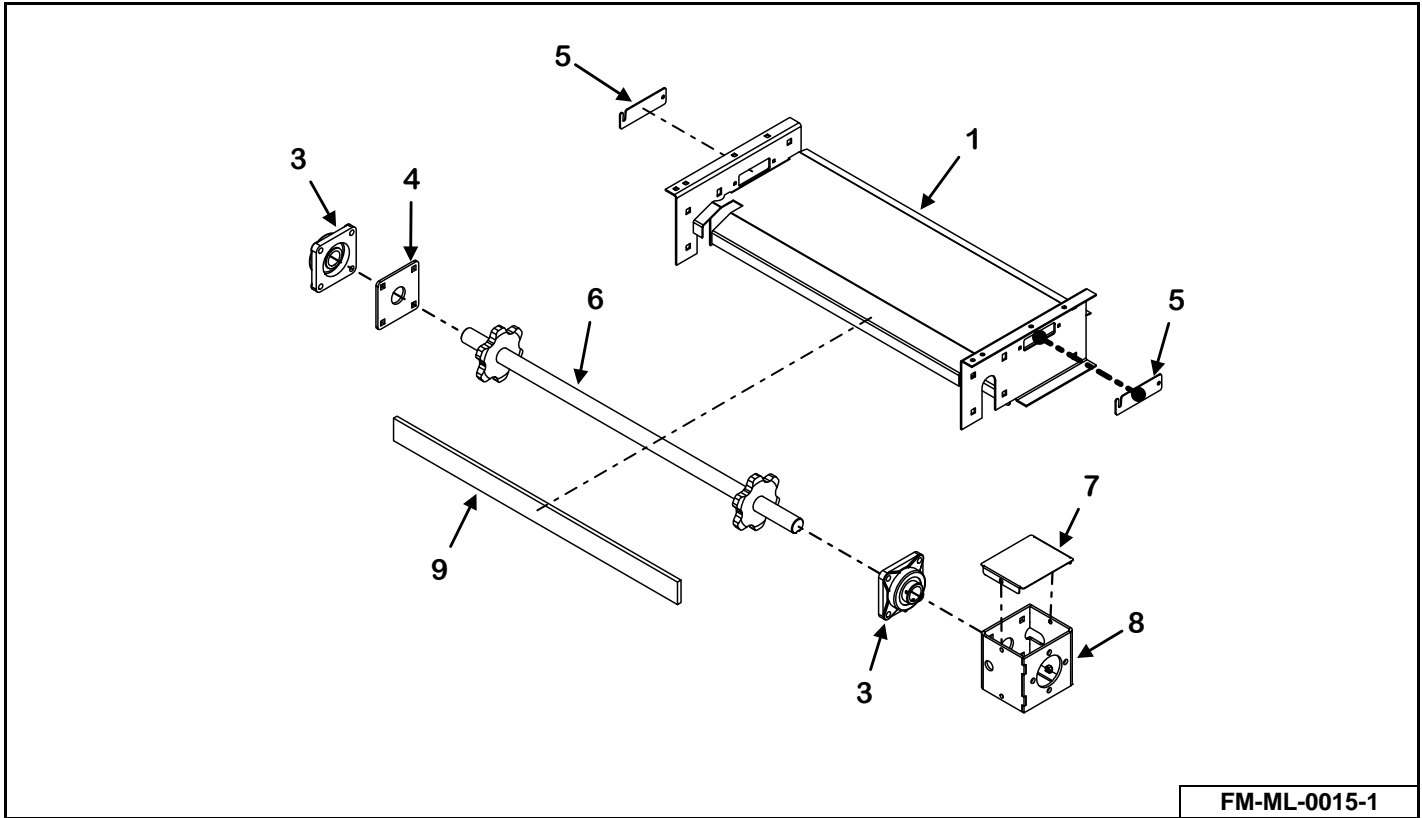

FRONT INCLINE CONVEYOR

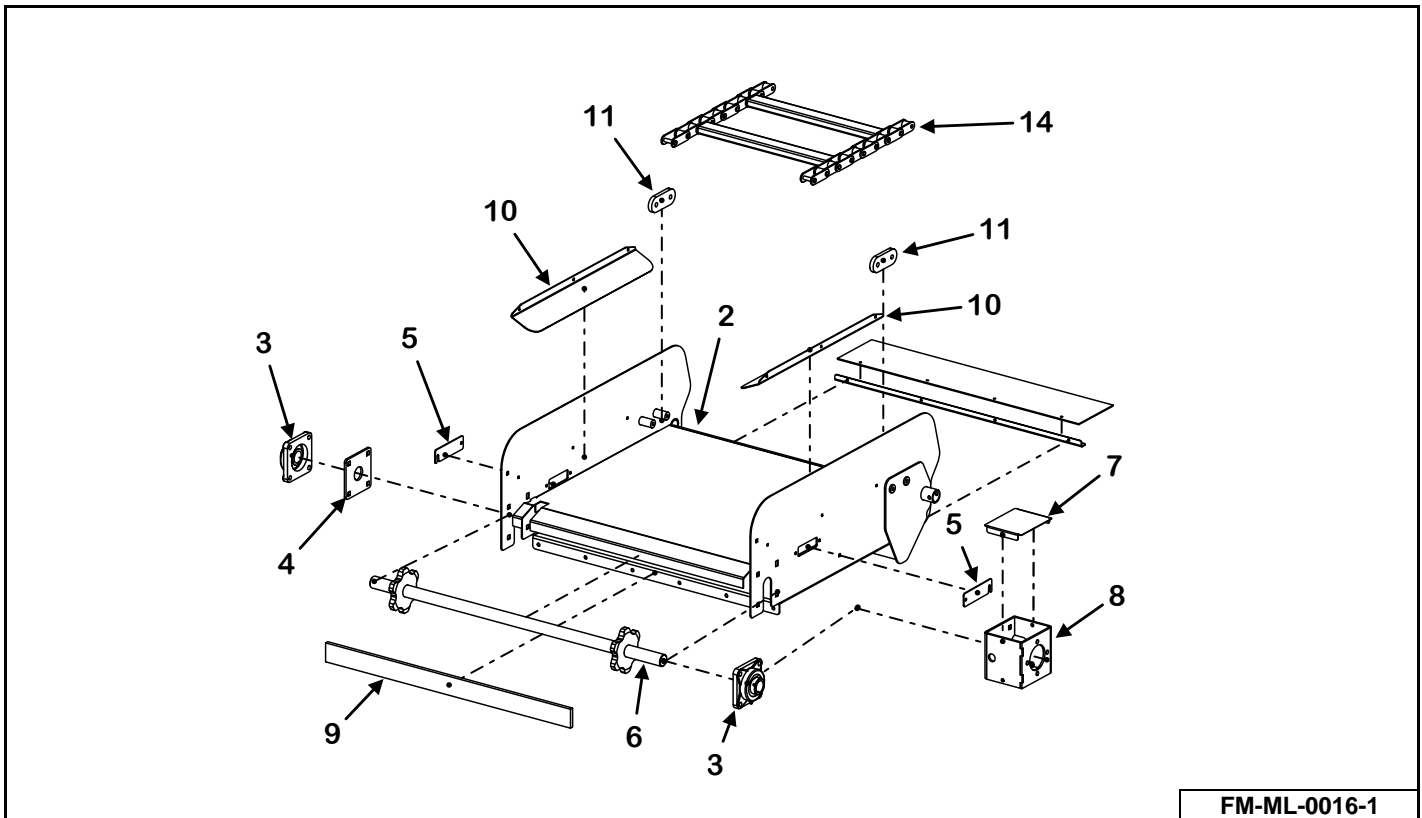

KEY	PART NUMBER	QTY	DESCRIPTION	MIXER MODEL
0	M3-1-5-0003	1	36" Wide Front Flat Drive End Assembly	815 - 1215
	VAM-DCI-36-I24	1	Front Incline Conveyor Assembly (36" x 24" Conveyor)	815 - 1215
	VAM-DCI-36-I36	1	Front Incline Conveyor Assembly (36" x 36" Conveyor)	815 - 1215
	VAM-DCI-36-I48	1	Front Incline Conveyor Assembly (36" x 48" Conveyor)	815 - 1215
	VAM-DCI-36-I60	1	Front Incline Conveyor Assembly (36" x 60" Conveyor)	815 - 1215
1	M3-1-5-0003-1	1	36" Front Conveyor Ext Weldment-Flat Drive End	815 - 1215
2	M3-1-5-0032-1	1	Front Incline Conveyor Weldment (36" x 24" Conveyor)	815 - 1215
	M3-1-5-0033-1	1	Front Incline Conveyor Weldment (36" x 36" Conveyor)	815 - 1215
	M3-1-5-0034-1	1	Front Incline Conveyor Weldment (36" x 48" Conveyor)	815 - 1215
	M3-1-5-0036-1	1	Front Incline Conveyor Weldment (36" x 60" Conveyor)	815 - 1215
3	14-0070	4	1-1/2" 4-Bolt Bearing	815 - 1215
4	M3-1-4-0002	1	Extension Bearing Mount Plate	815 - 1215
5	M3-1-4-0015-2	2	Chute Cover	815 - 1215
6	23-0254	1	36" Wide Conveyor Drive Shaft Weldment, Flat	815 - 1215
	23-0262	1	36" Wide Conveyor Drive Shaft Weldment, Incline	815 - 1215
7	M3-1-8-0006	1	Coupler Cover Plate	815 - 1215
8	M3-1-8-0034	1	Front Conveyor Motor Bracket	815 - 1215
9	49-0181	1	Front Chain Conveyor Belt	815 - 1215
10	M3-1-5-0011-2	2	Conveyor Chain Cover, Incline (24" Conveyor)	815 - 1215
	M3-1-5-0025	2	Conveyor Chain Cover, Incline (36" Conveyor)	815 - 1215
	M3-1-5-0014	2	Conveyor Chain Cover, Incline (48" Conveyor)	815 - 1215
	M3-1-4-0045-2	2	Conveyor Chain Cover, Incline (60" Conveyor)	815 - 1215
11	M3-1-7-0006	2	Chain Hold Down Plate	815 - 1215
12	850-5013-1.75Z	8	1/2"- 13 x 1-3/4" Carriage Bolt, Grade 5	815 - 1215
13	810-5013-Z	8	1/2" Spin Lock Nut	815 - 1215
14	11-0501-AS	1	Incline Ext. 81X Chain Assembly (36" x 24" Conveyor)	815 - 1215
	11-0508	1	Incline Ext. 81X Chain Assembly (36" x 36" Conveyor)	815 - 1215
	11-0509	1	Incline Ext. 81X Chain Assembly (36" x 48" Conveyor)	815 - 1215
	11-0510	1	Incline Ext. 81X Chain Assembly (36" x 60" Conveyor)	815 - 1215

FLAT CHAIN CONVEYOR HYDRAULIC SCHEMATIC

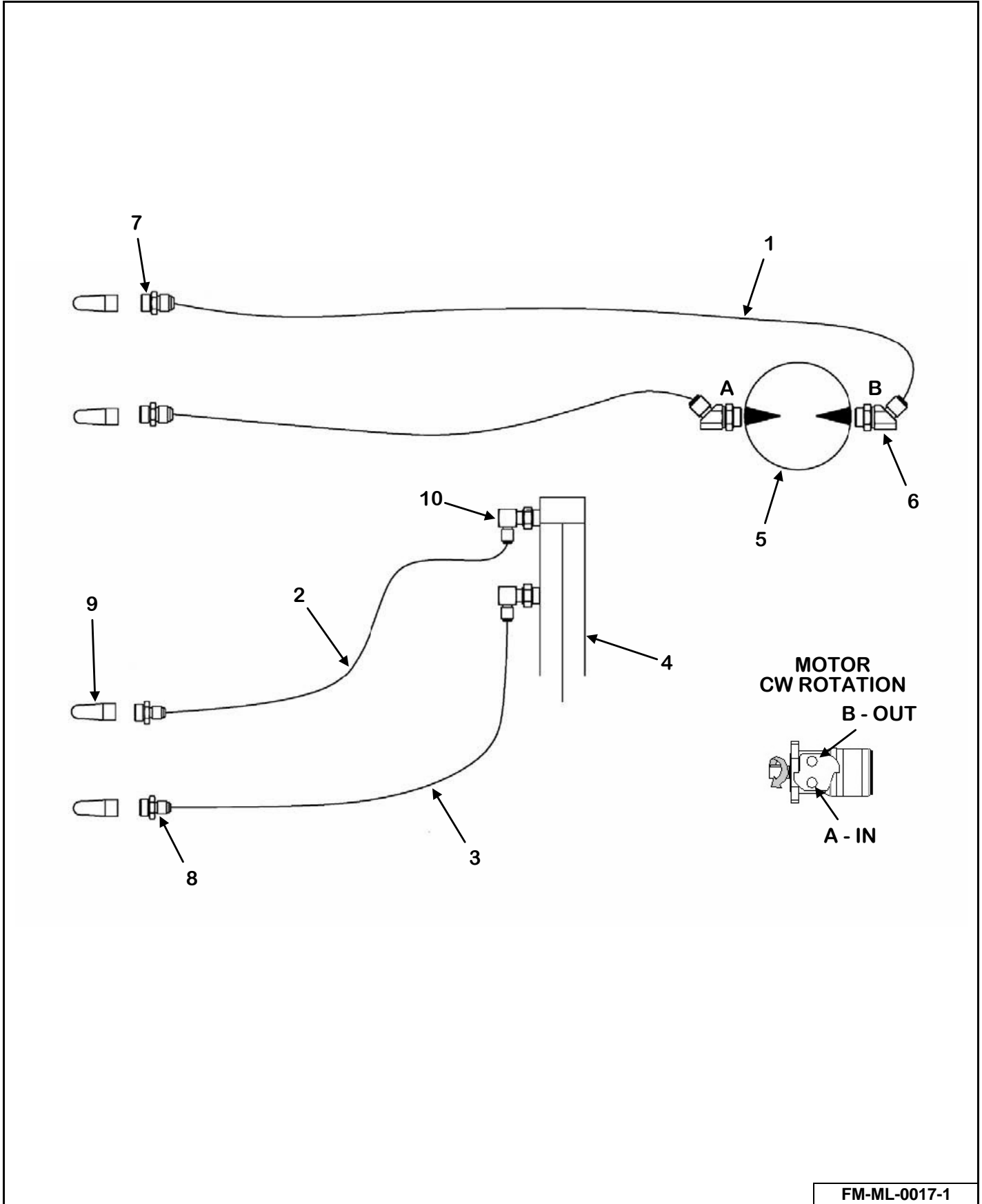

KEY	PART NUMBER	QTY	DESCRIPTION	MIXER MODEL
1	155-08R17-208-1	2	1/2" x 208" Hose Assembly	815 - 1215
2	155-04R17-197-1	1	1/4" x 197" Hose Assembly	815 - 1215
3	155-04R17-197-1	1	1/4" x 197" Hose Assembly	815 - 1215
4	155-2-16-1.125-1	1	2" x 16" x 1-1/8" Hydraulic Cylinder	815 - 1215
5	155-WR-12.1-1	1	12.1 Cubic Inch 2-Bolt Motor	815 - 1215
	155-WR-SK-1	1	Motor Seal Kit	815 - 1215
6	155-6802-8-10	2	#8 JIC Male, #10 ORB Male Adjustable 45°	815 - 1215
7	155-6400-8-8	2	#8 JIC Male, #8 ORB Male Straight Connector	815 - 1215
8	155-6400-6-8	2	#6 JIC Male, #8 ORB Male Straight Connector	815 - 1215
9	155-8010-15	4	#8 ORB Male Tip 1/2" Body Size	815 - 1215
10	155-6801-6-8	2	#6 JIC Male, #8 ORB Male Adjustable 90°	815 - 1215

FRONT DISCHARGE INCLINE CHAIN CONVEYOR HYDRAULIC SCHEMATIC
MODELS 815 - 1215: (36" X 24" CHAIN CONVEYOR)

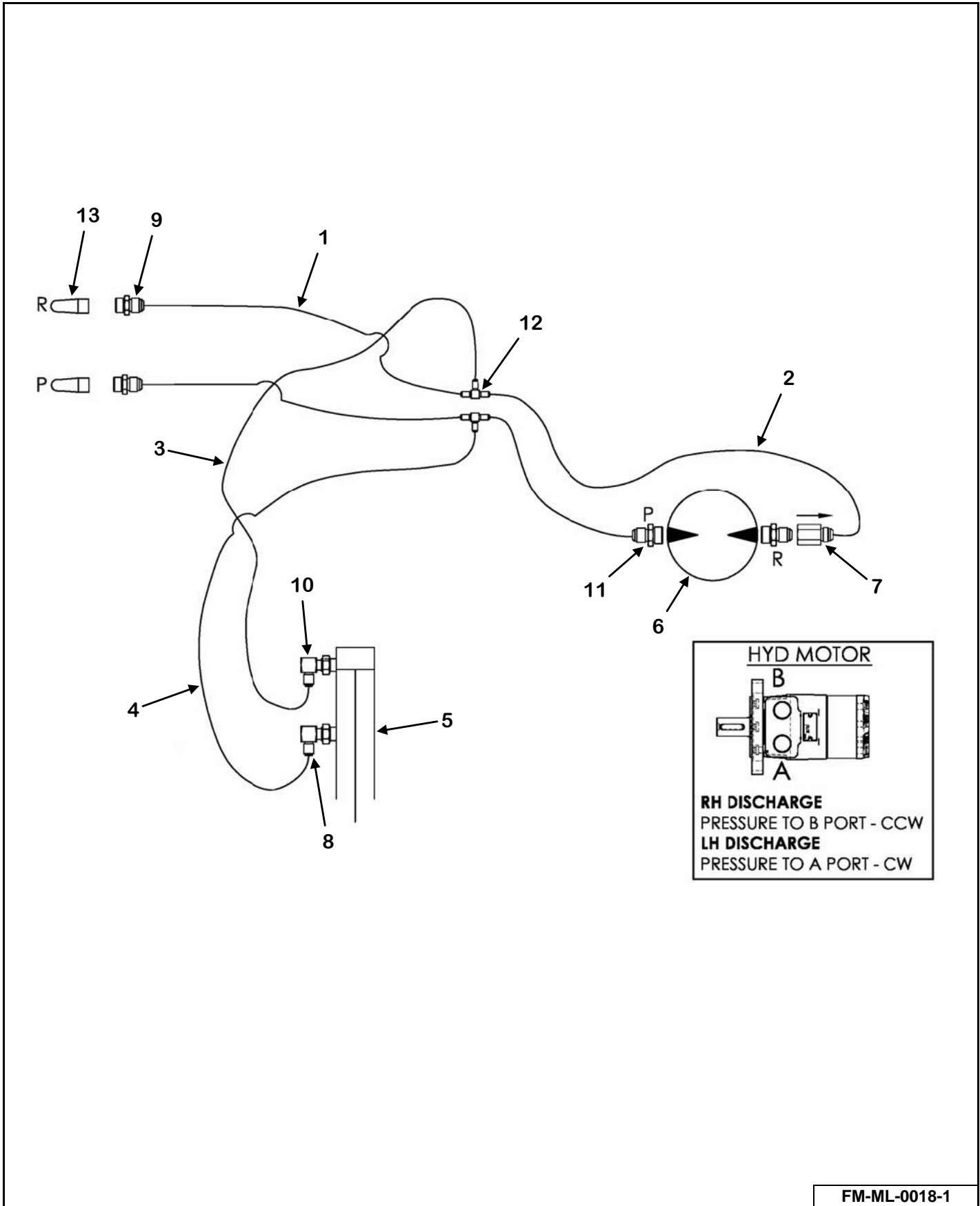

FM-ML-0018-1

KEY	PART NUMBER	QTY	DESCRIPTION	MIXER MODEL
1	155-08R17-138-1	2	1/2" x 138" Hose Assembly (36" x 24" Conveyor Chain)	815 - 1215
2	155-08R17-69-1	2	1/2" x 69" Hose Assembly (36" x 24" Conveyor Chain)	815 - 1215
3	155-04R17-28-1	1	1/4" x 28" Hose Assembly (36" x 24" Conveyor Chain)	815 - 1215
4	155-04R17-40-2	1	1/4" x 40" Hose Assembly (36" x 24" Conveyor Chain)	815 - 1215
5	155-2-8-1.125-1	1	2" x 8" x 1-1/8" Hydraulic Cylinder	815 - 1215
6	155-WR-12.1-1	1	12.1 Cubic Inch 2-Bolt Motor	815 - 1215
	155-WR-SK-1	1	Motor Seal Kit	815 - 1215
7	155-CV-8-1	1	Check Valve	815 - 1215
8	155-6801-6-8	1	#6 JIC Male, #8 ORB Male Adjustable 90°	815 - 1215
9	155-6400-8-8	2	#8 JIC Male, #8 ORB Male Straight Connector	815 - 1215
10	155-6801-6-8-55	1	#6 x #8 90° Adj Elbow With .055" Orifice	815 - 1215
11	155-6400-08-10	2	#8 JIC Male, #10 ORB Male Straight Connector	815 - 1215
12	155-2603-08-08-06	2	#8 x #8 x #8 JIC Male Tube Tee	815 - 1215
13	155-8010-15	2	#8 ORB Male Tip 1/2" Body Size	815 - 1215

FRONT DISCHARGE INCLINE CHAIN CONVEYOR HYDRAULIC SCHEMATIC
MODELS 815 - 1215: (36" X 36", 36" X 48", 36" X 60" CHAIN CONVEYOR)

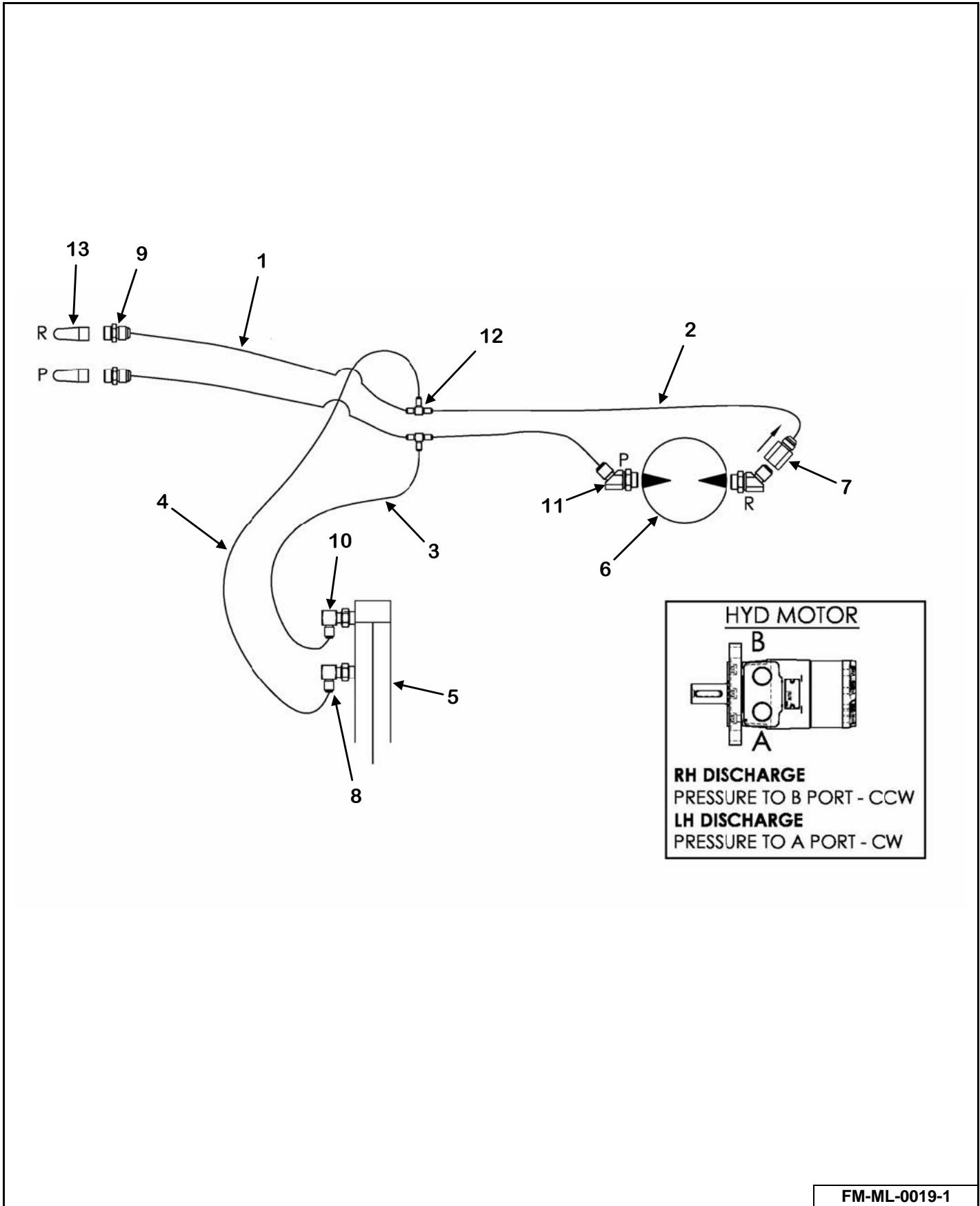

FM-ML-0019-1

KEY	PART NUMBER	QTY	DESCRIPTION	MIXER MODEL
1	155-08R17-138-1	2	1/2" x 138" Hose Assembly (36" x 36", 36" x 48", 36" x 60" Conveyor Chain)	815 - 1215
2	155-08R17-85-1	2	1/2" x 85" Hose Assembly (36" x 36" Conveyor Chain)	815 - 1215
	155-08R17-97-1	2	1/2" x 97" Hose Assembly (36" x 48" Conveyor Chain)	815 - 1215
	Call 1-800-325-9103	2	1/2" x _" Hose Assembly (36" x 60" Conveyor Chain)	815 - 1215
3	155-04R17-28-1	1	1/4" x 28" Hose Assembly (36" x 36", 36" x 48", 36" x 60" Conveyor Chain)	815 - 1215
4	155-04R17-40-2	1	1/4" x 40" Hose Assembly (36" x 36", 36" x 48", 36" x 60" Conveyor Chain)	815 - 1215
5	155-2-8-1.125-1	1	2" x 8" x 1-1/8" Hydraulic Cylinder	815 - 1215
6	155-WR-12.1-1	1	12.1 Cubic Inch 2-Bolt Motor	815 - 1215
	155-WR-SK-1	1	Motor Seal Kit	815 - 1215
7	155-CV-8-1	1	Check Valve	815 - 1215
8	155-6801-6-8	1	#6 JIC Male, #8 ORB Male Adjustable 90°	815 - 1215
9	155-6400-8-8	2	#8 JIC Male, #8 ORB Male Straight Connector	815 - 1215
10	155-6801-6-8-55	1	#6 x #8 90° Adj Elbow With .055" Orifice	815 - 1215
11	155-6802-8-10	2	#8 JIC Male, #10 ORB Male Adjustable 45°	815 - 1215
12	155-2603-08-08-06	2	#8 x #8 x #8 JIC Male Tube Tee	815 - 1215
13	155-8010-15	2	#8 ORB Male Tip 1/2" Body Size	815 - 1215

KEY	PART NUMBER	QTY	DESCRIPTION	MIXER MODEL
0	VAL-DBI-42-24-SL	1	42" x 24" Left Side Belt Conveyor Complete	815 - 1215
	VAL-DBI-42-24-SR	1	42" x 24" Right Side Belt Conveyor Complete	815 - 1215
	VAL-DBI-42-36-SL	1	42" x 36" Left Side Belt Conveyor Complete	815 - 1215
	VAL-DBI-42-36-SR	1	42" x 36" Right Side Belt Conveyor Complete	815 - 1215
	VAL-DBI-42-48-SL	1	42" x 48" Left Side Belt Conveyor Complete	815 - 1215
	VAL-DBI-42-48-SR	1	42" x 48" Right Side Belt Conveyor Complete	815 - 1215
	VAL-DBI-42-60-SL	1	42" x 60" Left Side Belt Conveyor Complete	815 - 1215
	VAL-DBI-42-60-SR	1	42" x 60" Right Side Belt Conveyor Complete	815 - 1215
1	M3-1-7-0044-1	1	42" x 24" Belt Conveyor Frame Weldment	815 - 1215
	M3-1-7-0035-1	1	42" x 36" Belt Conveyor Frame Weldment	815 - 1215
	M3-1-7-0041-1	1	42" x 48" Belt Conveyor Frame Weldment	815 - 1215
	M3-1-7-0039-1	1	42" x 60" Belt Conveyor Frame Weldment	815 - 1215
2	M3-1-7-0046	2	24" Side Belt Discharge Conveyor Floor	815 - 1215
	M3-1-7-0036	2	36" Side Belt Discharge Conveyor Floor	815 - 1215
	M3-1-7-0042	2	48" Side Belt Discharge Conveyor Floor	815 - 1215
	M3-1-7-0040	2	60" Side Belt Discharge Conveyor Floor	815 - 1215
3	VA-SCS-4224	1	24" Incline Skirt Seal Kit Prior to SN 19VM(0815202, 1015204, 1215209)	815 - 1215
	M3-1-7-0044-7	2	24" Incline Skirt Backer SN 19VM(0815202, 1015204, 1215209) & Later	815 - 1215
	VA-SCS-36	1	36" Incline Skirt Seal Kit Prior to SN 19VM(0815201, 1015204, 1215209)	815 - 1215
	M3-1-4-0035-4	2	36" Incline Skirt Backer SN 19VM(0815202, 1015204, 1215209) & Later	815 - 1215
	VA-SCS-48	1	48" Incline Skirt Seal Kit Prior to SN 19VM(0815201, 1015204, 1215209)	815 - 1215
	M3-1-4-0031-7	2	48" Incline Skirt Backer SN 19VM(0815202, 1015204, 1215209) & Later	815 - 1215
	VA-SCS-60	1	60" Incline Skirt Seal Kit Prior to SN 19VM(0815201, 1015204, 1215209)	815 - 1215
	M3-1-4-0051-7	2	60" Incline Skirt Backer SN 19VM(0815202, 1015204, 1215209) & Later	815 - 1215
4	M3-1-5-0049	1	Front Conveyor Motor Bracket	815 - 1215
5	M3-1-7-0035-1-5	2	Pivot Spacer Prior to SN 19VM(0815201, 1015204, 1215209)	815 - 1215
	M3-1-4-0057-1-4	2	Pivot Spacer SN 19VM(0815202, 1015204, 1215209) & Later	815 - 1215

KEY	PART NUMBER	QTY	DESCRIPTION	MIXER MODEL
6	M3-1-8-0006	1	Coupler Cover Plate	815 - 1215
7	See Page 152	1	Hydraulic Motor	815 - 1215
8	VA-SCS-4224	1	24" Incline Skirt Seal Kit Prior to SN 19VM(0815202, 1015204, 1215209)	815 - 1215
	49-0351	2	24" Incline Side Skirting SN 19VM(0815202, 1015204, 1215209) & Later	815 - 1215
	VA-SCS-36	1	36" Incline Skirt Seal Kit Prior to SN 19VM(0815201, 1015204, 1215209)	815 - 1215
	49-0347	2	36" Incline Side Skirting SN 19VM(0815202, 1015204, 1215209) & Later	815 - 1215
	VA-SCS-48	1	48" Incline Skirt Seal Kit Prior to SN 19VM(0815201, 1015204, 1215209)	815 - 1215
	49-0345	2	48" Incline Side Skirting SN 19VM(0815202, 1015204, 1215209) & Later	815 - 1215
	VA-SCS-60	1	60" Incline Skirt Seal Kit Prior to SN 19VM(0815201, 1015204, 1215209)	815 - 1215
	49-0343	2	60" Incline Side Skirting SN 19VM(0815202, 1015204, 1215209) & Later	815 - 1215
9	37-0013-1	1	Unit Coupler, 1" Bore 1/4" Keyway	815 - 1215
10	37-0013-2	1	Unit Coupler Chain, #50 16 Double With Connector	815 - 1215
11	110-50B16-1.50-1	1	Chain Coupler Sprocket 1.5 Bore x 0.375" Keyway	815 - 1215
	35-0006	1	3/8" x 3/8" x 1-1/4" Key	815 - 1215
12	14-0070	4	1-1/2" - 4 Bolt Bearing	815 - 1215
13	810-5013-Z	22	1/2" Spin Lock Nut (42" x 36" Belt Conveyor)	815 - 1215
	810-5013-Z	24	1/2" Spin Lock Nut (42" x 24", 42" x 48", 42" x 60" Belt Conveyor)	815 - 1215
14	850-5013-1.75Z	16	1/2"-13 x 1-3/4" Carriage Bolt, Grade 5	815 - 1215
15	M3-1-8-0002	3	Front Conveyor Bearing Mount	815 - 1215
16	49-0219	1	41.38" x 73" Belt, (42" x 24" Belt Conveyor).	815 - 1215
	49-0193-MB	1	41.38" x 93" Belt, (42" x 36" Belt Conveyor)	815 - 1215
	49-0199	1	41.38" x 117" Belt, (42" x 48" Belt Conveyor)	815 - 1215
	49-0198-MB	1	41.38" x 141" Belt, (42" x 60" Conveyor)	815 - 1215
	49-0193-3-AS	1	42" Conveyor Steel Belt Lacing Pin	815 - 1215
17	M3-1-7-0052	2	Conveyor Idler Roll Scraper	815 - 1215
	850-3118-.75Z	4	5/16"-18 x 3/4" Carriage Bolt	815 - 1215
	814-3118-Z	4	5/16"-18 Indented Locknut	815 - 1215
18	810-6311-Z	3	5/8" Spin Locknut	815 - 1215
19	M3-1-7-0029	1	Chute Pivot Rod 1" Diameter x 45-1/4"	815 - 1215
20	See Page 152	1	Hydraulic Cylinder	815 - 1215
21	M3-1-4-0005	1	Extension Hydraulic Mount Weldment	815 - 1215
22	M3-1-4-0006	1	Conveyor Link Arm Weldment	815 - 1215
23	23-0266	1	1.5 Shaft x 49.375" Drive Pulley	815 - 1215

SIDE DISCHARGE BELT CONVEYOR (CONT'D)

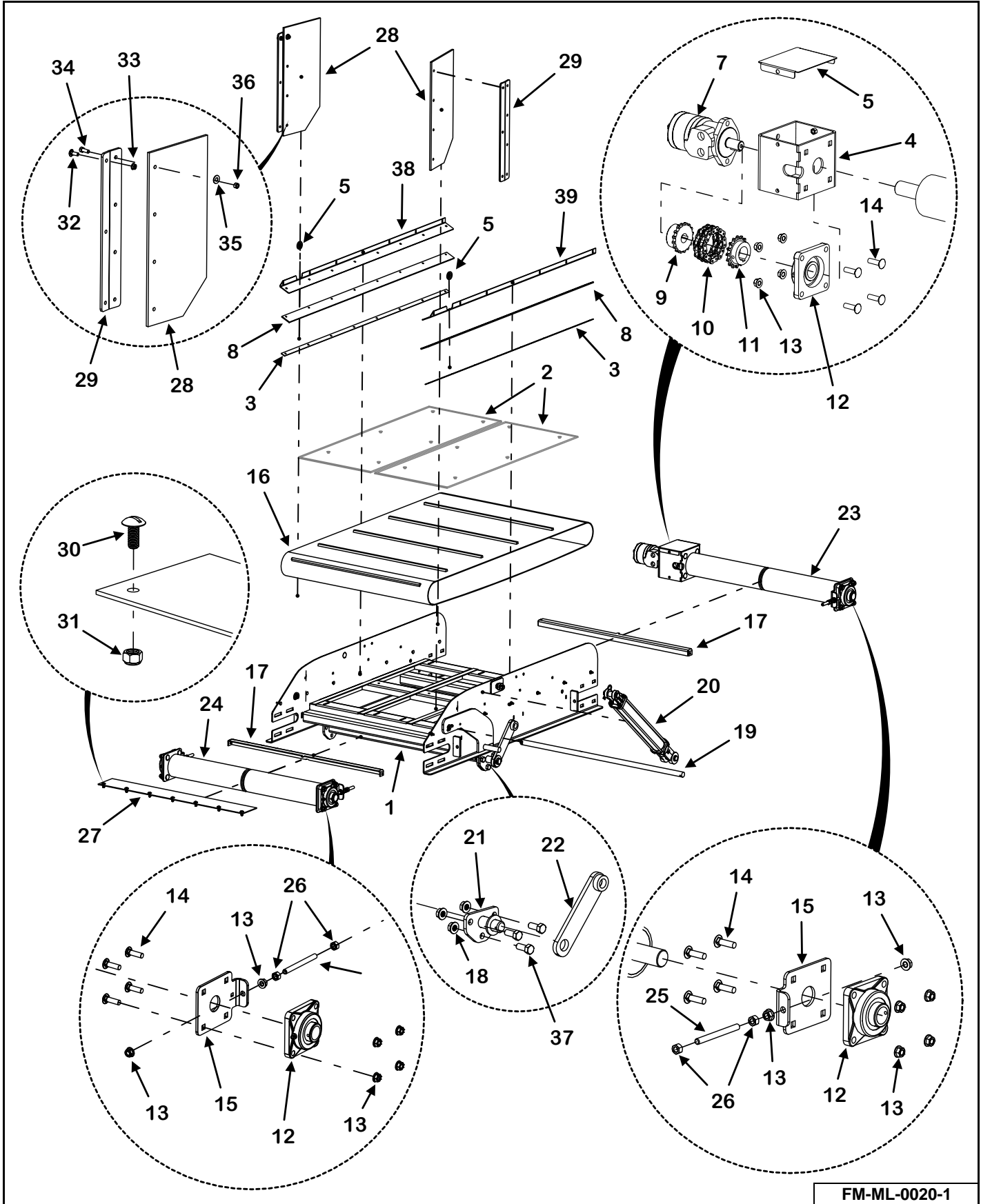

FM-ML-0020-1

KEY	PART NUMBER	QTY	DESCRIPTION	MIXER MODEL
24	23-0265	1	1.5 Shaft x 48.25" Cross Conveyor Idler Pulley	815 - 1215
25	830-5013-4Z	3	Tap Bolt, 1/2"-13 x 4"	815 - 1215
26	813-5013-Z	6	1/2"-13 Nut	815 - 1215
27	49-0171	1	Door Frame Seal	815 - 1215
28	M3-1-4-0024	2	Door Deflector (Belting)	815 - 1215
29	M3-1-4-0025	2	Belt Chute Deflector	815 - 1215
30	802T-3118-.75Z	7	5/16"-18 x 3/4" Truss Head Screw	815 - 1215
31	815-3118-Z	7	5/16"-18 Nylon Insert Lock Nut, Left Side	815 - 1215
32	850-3816-1Z	6	3/8"-16 x 1" Carriage Bolt, Grade 5	815 - 1215
33	810-3816-Z	6	3/8" Spin Lock Nut	815 - 1215
34	851-3816-1Z	8	3/8"-16 x 1" Grade 5 Machine Bolt	815 - 1215
35	805-0038-Z	4	3/8" Flat Washer	815 - 1215
36	815-3816-Z	8	3/8"-16 Nylon Insert Lock Nut	815 - 1215
37	851-6311-1.5Z	3	5/8"-11 x 1-1/2" Grade 5 Machine Bolt	815 - 1215
38	VA-SCS-4224	1	24" Incline Skirt Seal Kit Prior to SN 19VM(0815202, 1015204, 1215209)	815 - 1215
	M3-1-7-0044-5	1	24" Incline Side Skirt Bracket SN 19VM(0815202, 1015204, 1215209) & Later	815 - 1215
	VA-SCS-36	1	36" Incline Skirt Seal Kit Prior to SN 19VM(0815201, 1015204, 1215209)	815 - 1215
	M3-1-4-0035-5	1	36" Incline Side Skirt Bracket SN 19VM(0815202, 1015204, 1215209) & Later	815 - 1215
	VA-SCS-48	1	48" Incline Skirt Seal Kit Prior to SN 19VM(0815201, 1015204, 1215209)	815 - 1215
	M3-1-4-0031-5	1	48" Incline Side Skirt Bracket SN 19VM(0815202, 1015204, 1215209) & Later	815 - 1215
	VA-SCS-60	1	60" Incline Skirt Seal Kit Prior to SN 19VM(0815201, 1015204, 1215209)	815 - 1215
	M3-1-4-0051-5	1	60" Incline Side Skirt Bracket SN 19VM(0815202, 1015204, 1215209) & Later	815 - 1215
39	VA-SCS-4224	1	24" Incline Skirt Seal Kit Prior to SN 19VM(0815202, 1015204, 1215209)	815 - 1215
	M3-1-7-0044-6	1	24" Incline Side Skirt Bracket SN 19VM(0815202, 1015204, 1215209) & Later	815 - 1215
	VA-SCS-36	1	36" Incline Skirt Seal Kit Prior to SN 19VM(0815201, 1015204, 1215209)	815 - 1215
	M3-1-4-0035-6	1	36" Incline Side Skirt Bracket SN 19VM(0815202, 1015204, 1215209) & Later	815 - 1215
	VA-SCS-48	1	48" Incline Skirt Seal Kit Prior to SN 19VM(0815201, 1015204, 1215209)	815 - 1215
	M3-1-4-0031-6	1	48" Incline Side Skirt Bracket SN 19VM(0815202, 1015204, 1215209) & Later	815 - 1215
	VA-SCS-60	1	60" Incline Skirt Seal Kit Prior to SN 19VM(0815201, 1015204, 1215209)	815 - 1215
	M3-1-4-0051-6	1	60" Incline Side Skirt Bracket SN 19VM(0815202, 1015204, 1215209) & Later	815 - 1215

SIDE DISCHARGE CHAIN CONVEYOR

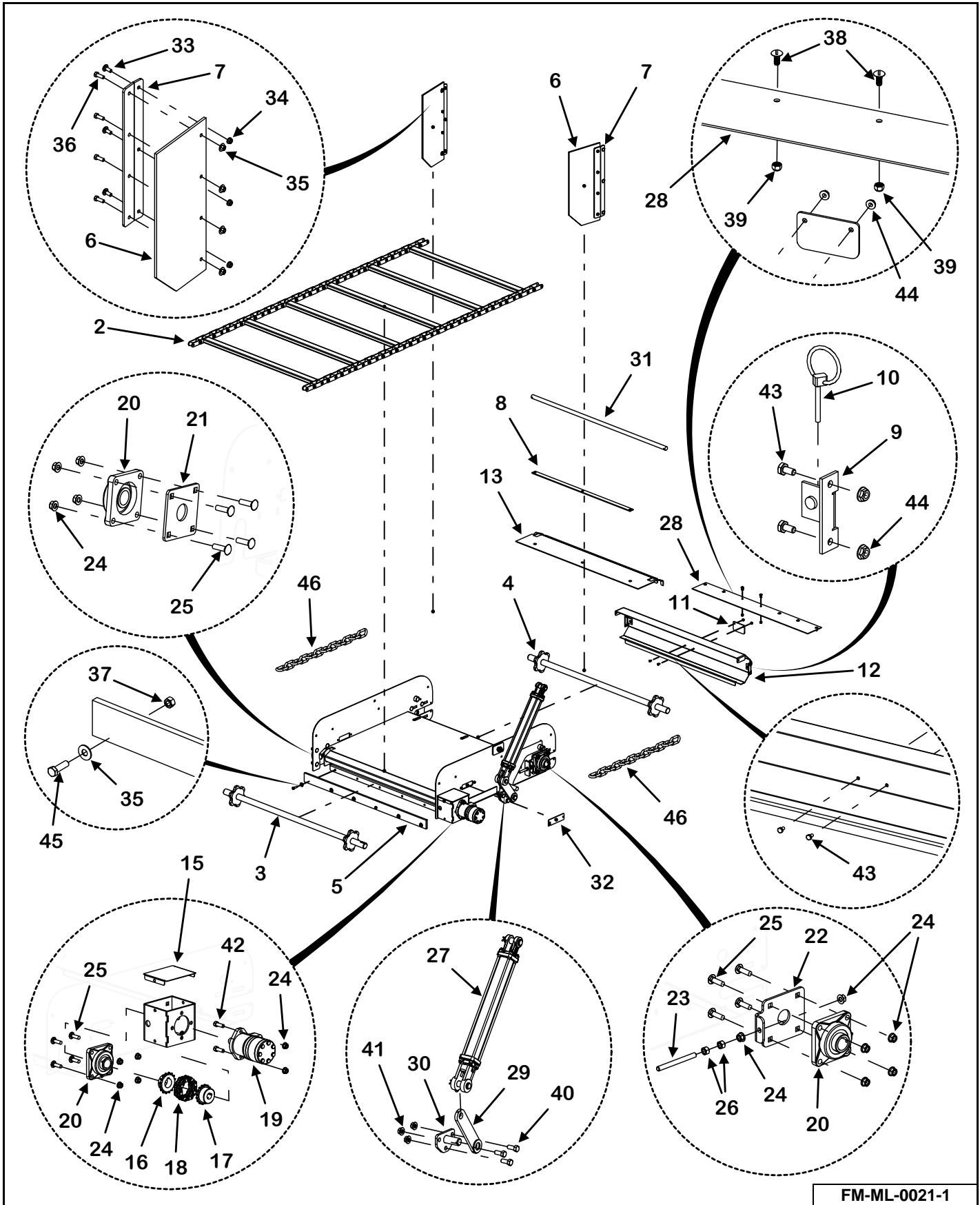

FM-ML-0021-1

KEY	PART NUMBER	QTY	DESCRIPTION	MIXER MODEL
0	VAL-DCI-42-36-SL	1	42" x 36" Left Chain Side Extension Complete	815 - 1215
	VAL-DCI-42-36-SR	1	42" x 36" Right Chain Side Extension Complete	815 - 1215
	VAL-DCI-42-48-SL	1	42" x 48" Left Chain Side Extension Complete	815 - 1215
	VAL-DCI-42-48-SR	1	42" x 48" Right Chain Side Extension Complete	815 - 1215
	VAL-DCI-42-72-SL	1	42" x 72" Left Chain Side Extension Complete	815 - 1215
	VAL-DCI-42-72-SR	1	42" x 72" Right Chain Side Extension Complete	815 - 1215
1	M3-1-12-0017-1	1	42" x 36" Chain Conveyor Weldment	815 - 1215
	M3-1-12-0018-1	1	42" x 48" Chain Conveyor Weldment	815 - 1215
	M3-1-12-0021-1	1	42" x 60" Chain Conveyor Weldment	815 - 1215
	M3-1-12-0019-1	1	42" x 72" Chain Conveyor Weldment	815 - 1215
2	11-0279	1	42" x 36" Side Discharge Conveyor 81X Chain Assembly	815 - 1215
	11-0280	1	42" x 48" Side Discharge Conveyor 81X Chain Assembly	815 - 1215
	11-0315	1	42" x 60" Side Discharge Conveyor 81X Chain Assembly	815 - 1215
	11-0288	1	42" x 72" Side Discharge Conveyor 81X Chain Assembly	815 - 1215
3	23-0258	1	Conveyor Drive Shaft Weldment	815 - 1215
4	23-0259	1	Conveyor Idler Shaft Weldment	815 - 1215
5	49-0180	1	Side Chain Conveyor Belt	815 - 1215
6	M3-1-4-0024	2	Door Deflector (Belting)	815 - 1215
7	M3-1-4-0025	2	Belt Chute Deflector	815 - 1215
8	M3-1-12-0009	1	Extension Adjustment Bracket Weldment	815 - 1215
9	M3-1-7-0034	2	Conveyor Extension Cover Latch Weldment	815 - 1215
10	823-0003	2	Lynch Pin 3/16" x 1-1/4"	815 - 1215
11	M3-1-7-0005-2	1	Conveyor Extension Cover Handle	815 - 1215
12	M3-1-12-0003-AS	1	Extension Back Plate	815 - 1215
13	M3-1-12-0002	1	Extension Sprocket Cover	815 - 1215
14	M3-1-8-0034	1	Front Conveyor Motor Bracket	815 - 1215
15	M3-1-8-0006	1	Coupler Cover Plate	815 - 1215
16	110-50B16-1.50-1	1	Chain Coupler Sprocket	815 - 1215
17	37-0013-1	1	Unit Coupler, 1" Bore 1/4" Keyway	815 - 1215
18	37-0013-2	1	Unit Coupler Chain, #50 16 Double with Connector	815 - 1215

SIDE DISCHARGE CHAIN CONVEYOR (CONT'D)

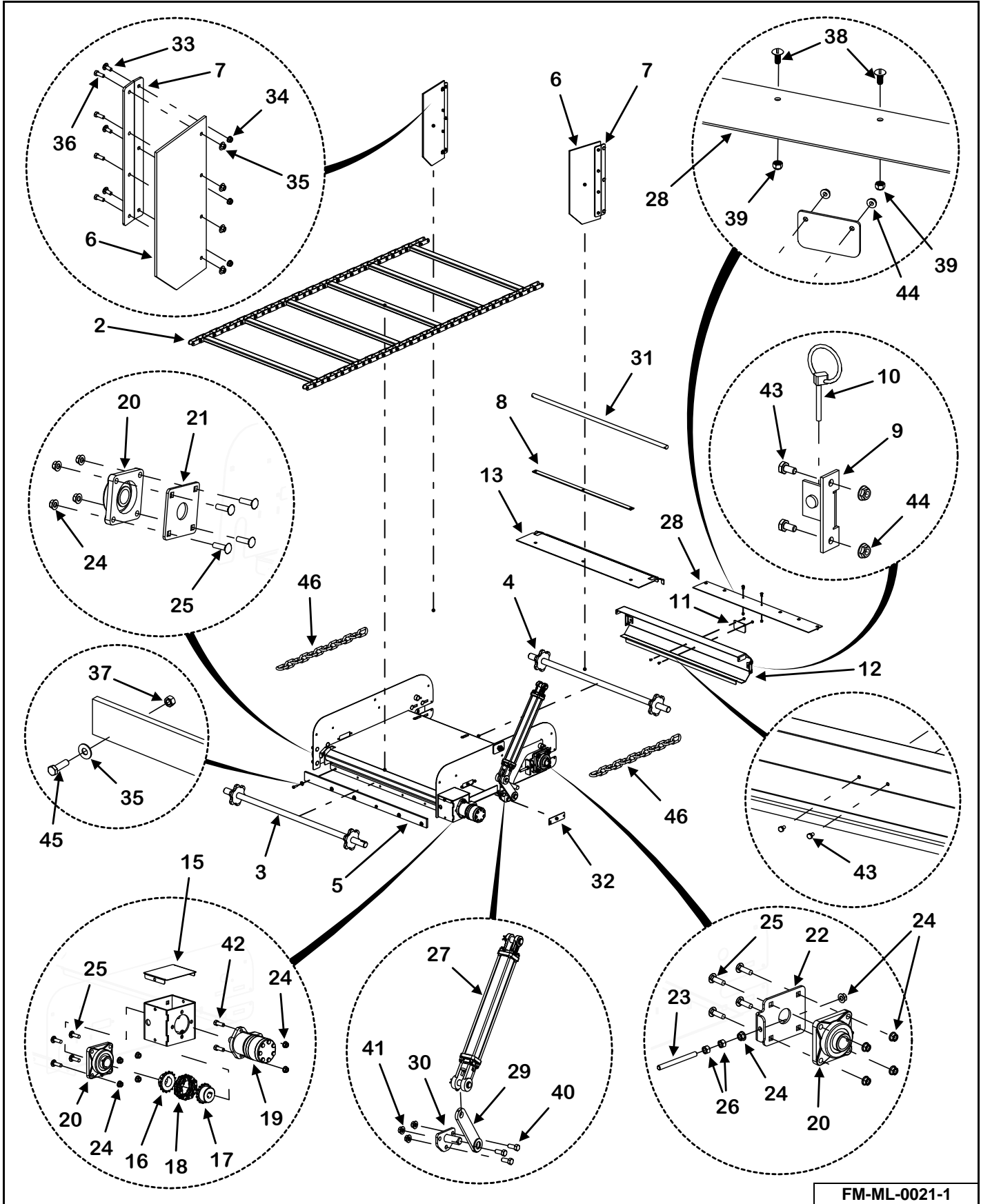

FM-ML-0021-1

KEY	PART NUMBER	QTY	DESCRIPTION	MIXER MODEL
19	See Page 152		Hydraulic Motor	815 - 1215
20	14-0070	1	1-1/2" 4-Bolt Bearing	815 - 1215
21	M3-1-4-0002	1	Extension Bearing Mount Plate	815 - 1215
22	M3-1-8-0002	2	Front Conveyor Bearing Mount	815 - 1215
23	830-5013-4Z	2	Tap Bolt, 1/2"-13 x 4"	815 - 1215
24	810-5013-Z	22	1/2"-13 Spin Lock Nut	815 - 1215
25	850-5013-1.75Z	16	1/2"-13 x 1-3/4" Carriage Bolt, Grade 5	815 - 1215
26	813-5013-Z	8	1/2"-13 Nut	815 - 1215
27	See Page 152		Hydraulic Cylinder	815 - 1215
28	49-0171	1	Door Frame Seal	815 - 1215
29	M3-1-4-0006	1	Conveyor Link Arm Weldment	815 - 1215
30	M3-1-4-0005	1	Extension Hydraulic Mount Weldment	815 - 1215
31	M3-1-12-0008	1	Chute Pivot Rod	815 - 1215
32	M3-1-4-0015-2	2	Chute Cover	815 - 1215
33	850-3816-1Z	6	3/8"-16 x 1" Carriage Bolt	815 - 1215
34	810-3816-Z	6	3/8"-16 Spin Lock Nut	815 - 1215
35	805-0038-Z	6	3/8" Flat Washer	815 - 1215
36	851-3816-1Z	8	3/8"-16 x 1" Machine Bolt	815 - 1215
37	815-3816-Z	14	3/8"-16 Nylon Insert Lock Nut	815 - 1215
38	802T-3118-.75Z	7	5/16"-18 x 3/4" Truss Head Machine Screw	815 - 1215
39	815-3118-Z	7	5/16"-18 Nylon Insert Lock Nut	815 - 1215
40	851-6311-1.5Z	3	5/8"-11 x 1-1/2" Machine Bolt	815 - 1215
41	810-6311-Z	3	5/8"-11 Spin Locknut	815 - 1215
42	851-5013-1.5Z	2	1/2"-13 x 1-1/2" Bolt	815 - 1215
43	851-2520-.5Z	4	1/4"-20 x 1/2" Machine Bolt	815 - 1215
44	810-2520-Z	4	1/4"-20 Spin Lock Nut	815 - 1215
45	851-3816-1.25Z	6	3/8"-16 x 1-1/4" Machine Bolt	815 - 1215
46	M3-1-4-0001-2	2	Chain Stop 1/4" Chain	815 - 1215

SIDE DISCHARGE INCLINE BELT & CHAIN CONVEYOR HYDRAULIC SCHEMATIC
MODELS 815 / 1015 / 1215: (42" X 24", 42" X 36", 42" X 48", 42" X 60", 42" X 72" BELT & CHAIN CONVEYOR)

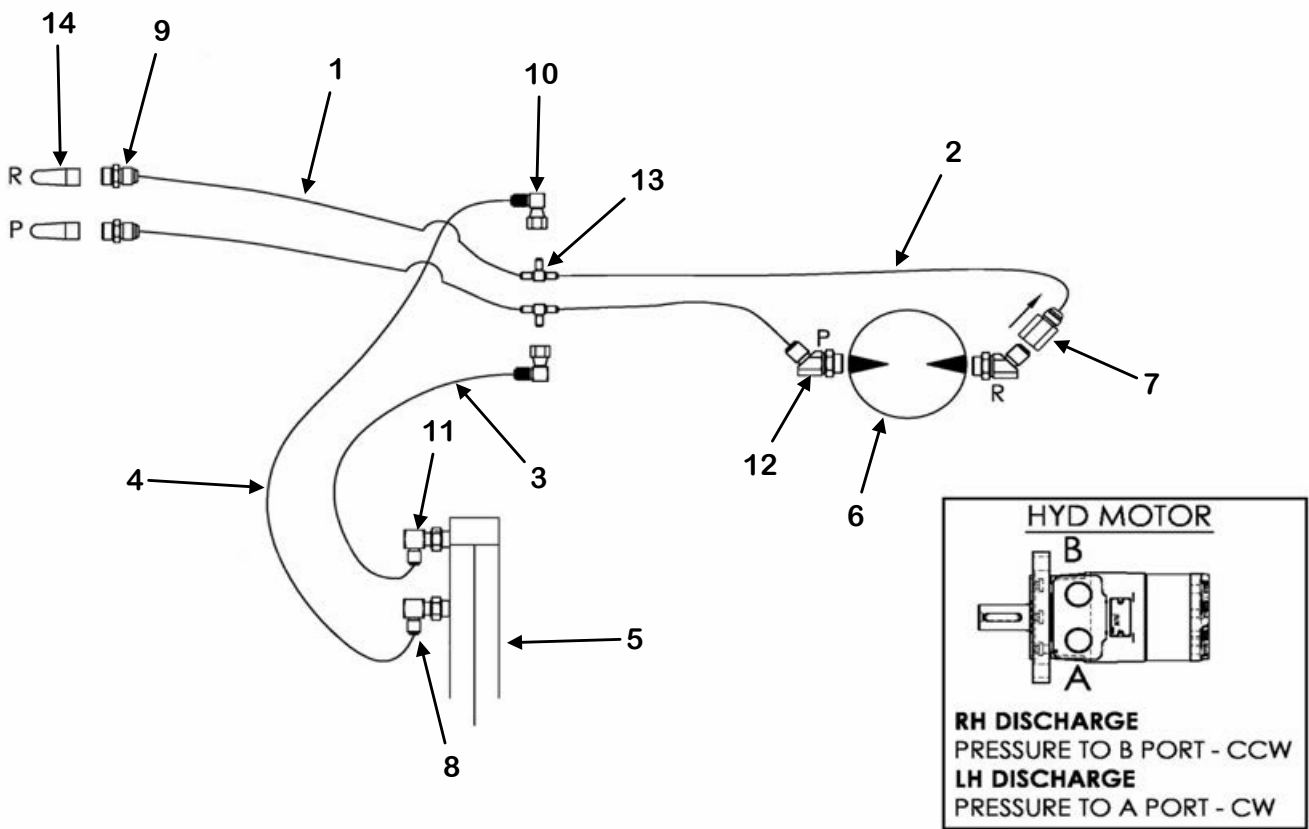

FM-ML-0023-1

KEY	PART NUMBER	QTY	DESCRIPTION	MIXER MODEL
1	155-08R17-208-1	2	1/2" x 208" Hose Assembly	815 - 1215
2	155-08R17-85-1	2	1/2" x 85" Hose Assembly (42" x 24", 42" x 36", 42" x 48" Belt & Chain Conveyor)	815 - 1215
	Call 1-800-325-9103	2	1/2" x _" Hose Assembly (42" x 60" Belt & Chain Conveyor)	815 - 1215
	155-08R17-97-1	2	1/2" x 97" Hose Assembly (42" x 72" Belt & Chain Conveyor)	815 - 1215
3	155-04R17-70-1	1	1/4" x 70" Hose Assembly	815 - 1215
4	155-04R17-52-1	1	1/4" x 52" Hose Assembly	815 - 1215
5	155-2-16-1.125-1	1	2" x 16" x 1-1/8" Hydraulic Cylinder	815 - 1215
6	155-WR-12.1-1	1	12.1 Cubic Inch 2-Bolt Motor	815 - 1215
	155-WR-SK-1	1	Motor Seal Kit	815 - 1215
7	155-CV-8-1	1	Check Valve	815 - 1215
8	155-6801-6-8	1	#6 JIC Male, #8 ORB Male 90 Degree Adjustable Elbow	815 - 1215
9	155-6400-8-8	2	#8 JIC Male, #8 ORB Male Straight Connector	815 - 1215
10	155-6500-06-06	2	#6 JIC Male, #6 JIC Female Swivel 90°	815 - 1215
11	155-6801-6-8-55	1	#6 x #8 90° Adj Elbow With .055" Orifice	815 - 1215
12	155-6802-8-10	2	#8 JIC Male, #10 ORB Male Adjustable 45°	815 - 1215
13	155-2603-08-08-06	2	#8 x #8 x #8 JIC Male Tube Tee	815 - 1215
14	155-8010-15	2	#8 ORB Male Tip 1/2" Body Size	815 - 1215

DOOR

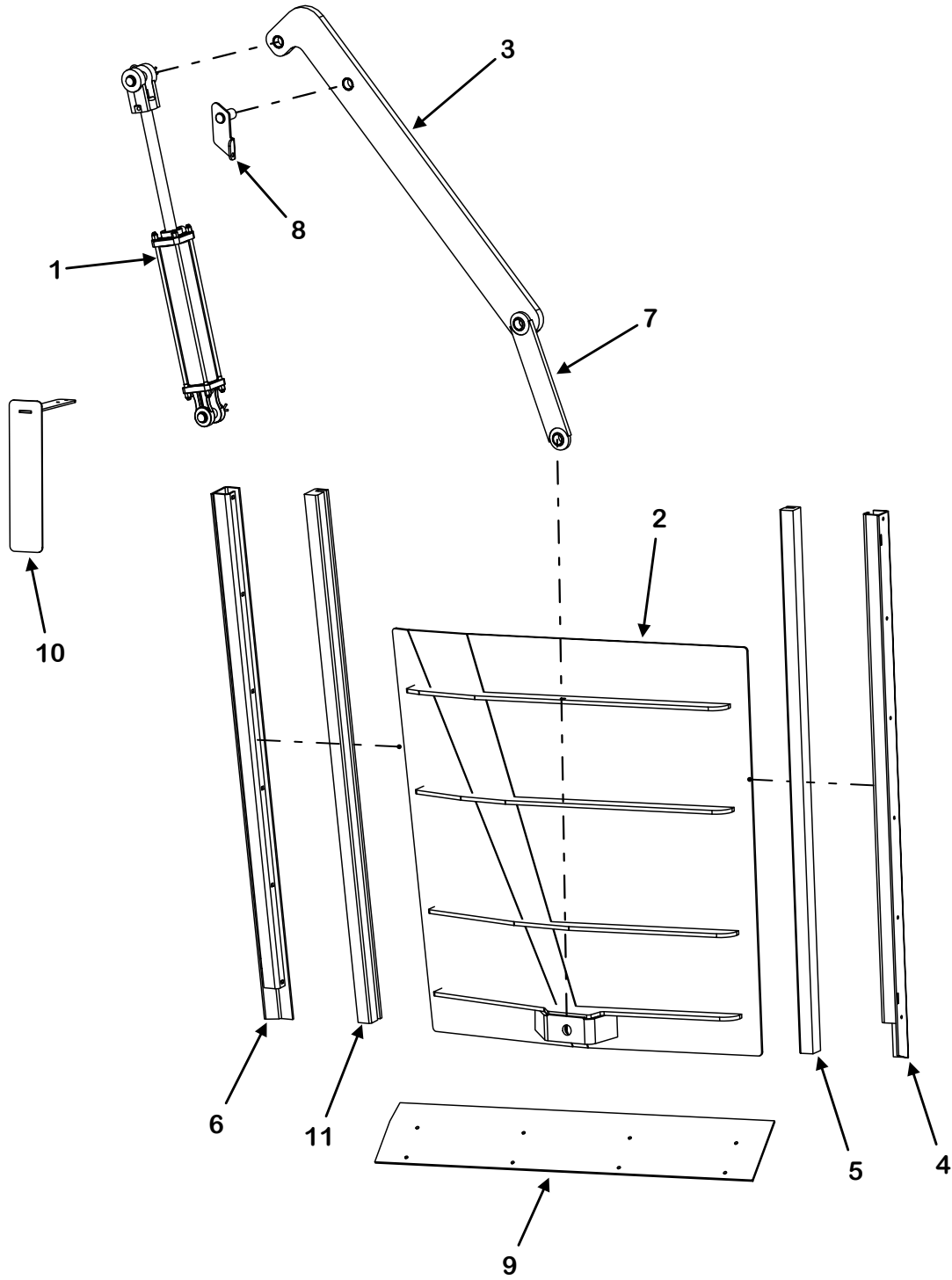

FM-ML-0024-1

KEY	PART NUMBER	QTY	DESCRIPTION	MIXER MODEL
1	155-2.5-12-1.125-1	1	2-1/2" x 12" x 1-1/8" Hydraulic Cylinder	815 - 1215
2	M6-1-8-0005	1	Rear / Front Door Weldment	815 - 1215
	M6-1-8-0011	1	Left Side Door Weldment	815 - 1215
	M6-1-8-0014	1	Right Side Door Weldment	815 - 1215
3	M6-1-8-0006	1	Rear / Front Door Arm	815 - 1215
	M6-1-8-0012	1	Left / Right Door Arm	815 - 1215
	M6-1-8-0006-2	2	Spring Bushing 1" ID x 1-1/4" OD x 3/4"	815 - 1215
4	M6-1-8-0002	1	Right Door Frame Guide Assembly	815 - 1215
5	M6-1-10-0007-R	1	Right Poly Door Slide (Facing Door)	815 - 1215
	850-3118-2.5Z	6	Carriage Bolt, 5/16"-18 x 2-1/2"	815 - 1215
	814-3118-Z	6	Indented Lock Nut, 5/16"-18	815 - 1215
6	M6-1-8-0004	1	Left Door Frame Guide Assembly	815 - 1215
7	M6-1-8-0008	1	Door Link Arm Assembly	815 - 1215
	851-1008-3Z	2	Machine Bolt, 1"-8 x 3"	815 - 1215
	815-1008-Z	2	Lock Nut, 1"-8 Nylon Insert	815 - 1215
8	M6-1-8-0009	1	Front & Rear Door Link Pivot Pin Assembly	815 - 1215
	M6-1-8-0015	1	Left Door Pivot Pin Assembly	815 - 1215
	M6-1-8-0016	1	Right Door Pivot Pin Assembly	815 - 1215
	851-3816-1.25Z	1	3/8"-16 x 1-1/4" Machine Bolt	815 - 1215
	805-0038-Z	2	3/8" Flat Washer	815 - 1215
	815-3816-Z	1	3/8"-16 Nylon Insert Lock Nut	815 - 1215
9	M11-1-0019	1	Magnet Cover Plate (Side Door Only)	815 - 1215
10	46-M-0006	AR	Door Open Indicator Decal	815 - 1215
11	M6-1-10-0007-L	1	Left Poly Door Slide (Facing Door)	815 - 1215
	850-3118-2.5Z	6	Carriage Bolt, 5/16"-18 x 2-1/2"	815 - 1215
	814-3118-Z	6	Indented Lock Nut, 5/16"-18	815 - 1215

**OPTIONAL REAR DOOR HYDRAULIC SCHEMATIC FOR
FRONT DOOR & SIDE DOOR MODELS**

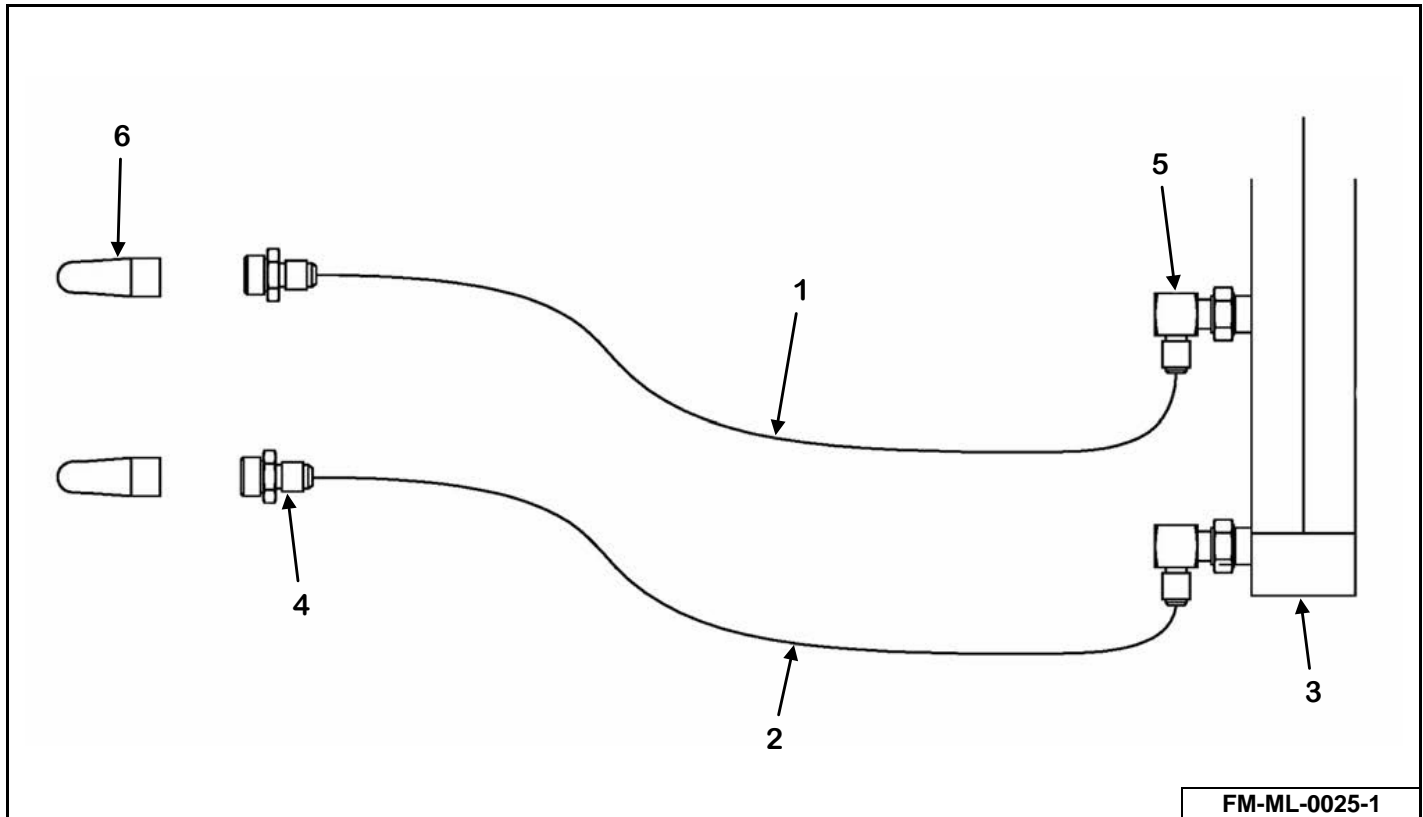

KEY	PART NUMBER	QTY	DESCRIPTION	MIXER MODEL
1	155-04R17-387-1	1	1/4" x 387" Hose Assembly (Optional Rear Door For Side Door)	815 - 1215
	155-04R17-417-1	1	1/4" x 417" Hose Assembly (Optional Rear Door For Front Door)	815 - 1215
2	155-04R17-373-1	1	1/4" x 373" Hose Assembly (Optional Rear Door For Side Door)	815 - 1215
	155-04R17-408-1	1	1/4" x 408" Hose Assembly (Optional Rear Door For Front Door)	815 - 1215
3	155-2-5-12-1.125-1	1	2-1/2" x 12" x 1-1/8" Hydraulic Cylinder	815 - 1215
4	155-6400-6-8	2	#6 JIC Male, #8 ORB Male Straight Connector	815 - 1215
5	155-6801-6-8	2	#6 JIC Male, #8 ORB Male Adjustable 90°	815 - 1215
6	155-8010-15	2	#8 ORB Male Tip 1/2" Body Size	815 - 1215

DOOR HYDRAULIC SCHEMATIC FRONT / LEFT / RIGHT / DUAL LEFT & RIGHT DOOR

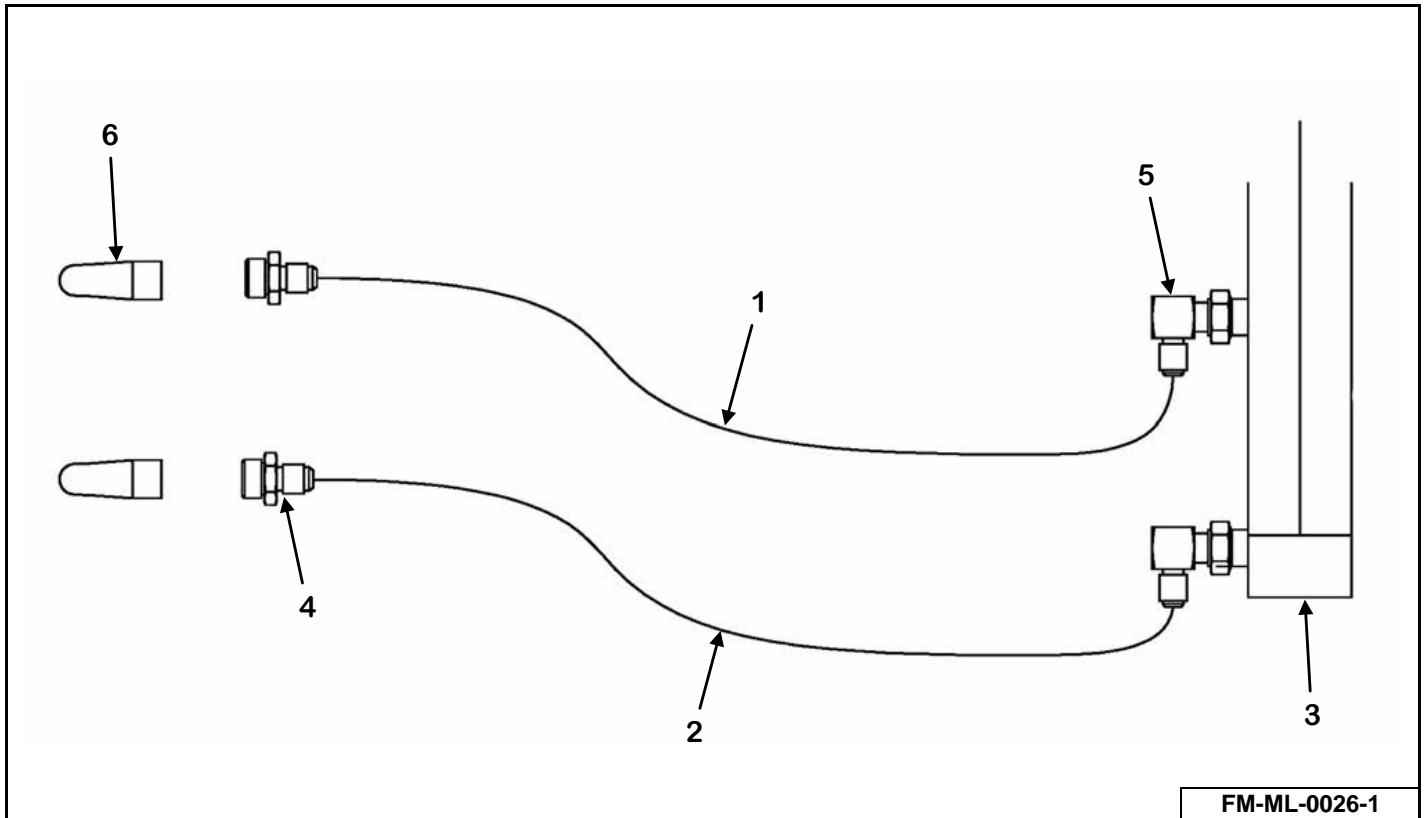

FM-ML-0026-1

KEY	PART NUMBER	QTY	DESCRIPTION	MIXER MODEL
1	155-04R17-251-1	1	1/4" x 251" Hose Assembly (Left & Right Doors)	815 - 1215
	155-04R17-233-1	1	1/4" x 233" Hose Assembly (Front Door)	815 - 1215
2	155-04R17-240-1	1	1/4" x 240" Hose Assembly (Left & Right Doors)	815 - 1215
	155-04R17-218-1	1	1/4" x 218" Hose Assembly (Front Door)	815 - 1215
3	155-2-5-12-1.125-1	1	2-1/2" x 12" x 1-1/8" Hydraulic Cylinder	815 - 1215
4	155-6400-6-8	2	#6 JIC Male, #8 ORB Male Straight Connector	815 - 1215
5	155-6801-6-8	2	#6 JIC Male, #8 ORB Male Adjustable 90°	815 - 1215
6	155-8010-15	2	#8 ORB Male Tip 1/2" Body Size	815 - 1215

LADDER

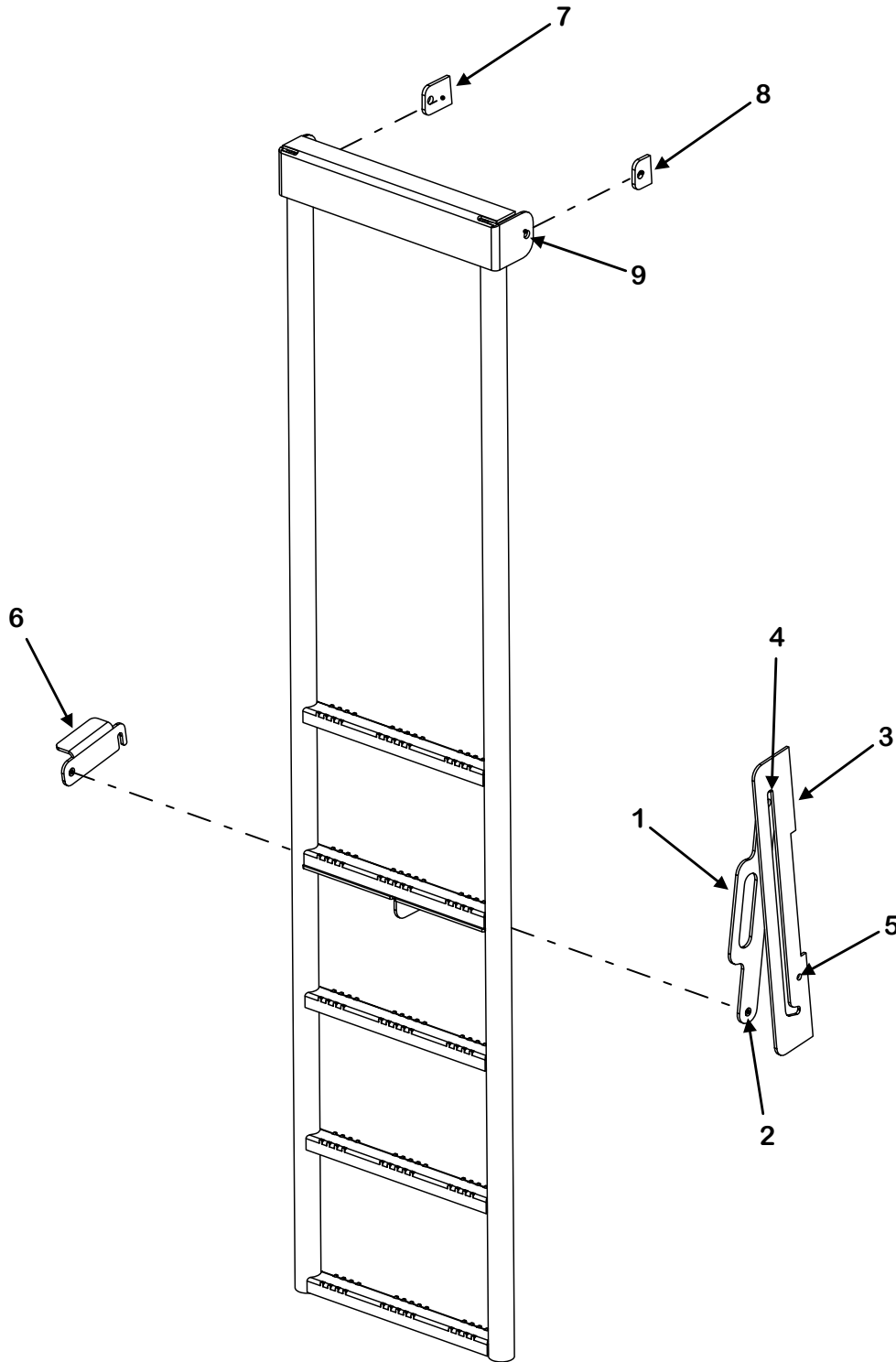

FM-ML-0027-1

KEY	PART NUMBER	QTY	DESCRIPTION	MIXER MODEL
0	M10-1-8-0002	1	Ladder Weldment	815
	M10-1-10-0001	1	Ladder Weldment	1015
	M10-1-12-0001	1	Ladder Weldment	1215
1	M10-1-4-0001-4	1	Ladder Handle	815 - 1215
2	851-5013-1.75Z	1	1/2"-13 x 1-3/4" Bolt	815 - 1215
	805-0050-Z	2	1/2" Flat Washer	815 - 1215
	815-5013-Z	1	1/2"-13 Nylon Lock Nut	815 - 1215
3	M2-1-4-0001-48	1	Ladder Guide (Welded On)	815
	M2-1-10-0001-16	1	Ladder Guide (Welded On)	1015
	M2-1-12-0001-25	1	Ladder Guide (Welded On)	1215
4	851-5013-1.5Z	1	1/2"-13 x 1-1/2" Bolt	815 - 1215
	805-0050-Z	2	1/2" Flat Washer	815 - 1215
	815-5013-Z	1	1/2"-13 Nylon Lock Nut	815 - 1215
5	851-3816-1.5Z	1	3/8"-16 x 1-1/2" Bolt	815 - 1215
	810-3816-Z	2	3/8" Spin Lock Nut	815 - 1215
6	M10-1-4-0001-5	1	Ladder Latch	815 - 1215
7	M2-1-10-0001-15	1	Left Ladder Mount, Front Discharge (Welded On)	815/1015
	M2-1-10-0001-11	1	Left Ladder Mount, Side Discharge (Welded On)	815/1015
	M2-1-12-0001-23	1	Left Ladder Mount, Side Discharge (Welded On)	1215
8	M2-1-10-0001-14	1	Right Ladder Mount, Front Discharge (Welded On)	815/1015
	M2-1-10-0001-12	1	Right Ladder Mount, Side Discharge (Welded On)	815/1015
	M2-1-12-0001-24	1	Right Ladder Mount, Side Discharge (Welded On)	1215
9	851-5013-1.5Z	2	1/2"-13 x 1-1/2" Bolt	815 - 1215
	805-0050-Z	2	1/2" Flat Washer	815 - 1215
	815-5013-Z	2	1/2"-13 Nylon Lock Nut	815 - 1215

VIEWING PLATFORM

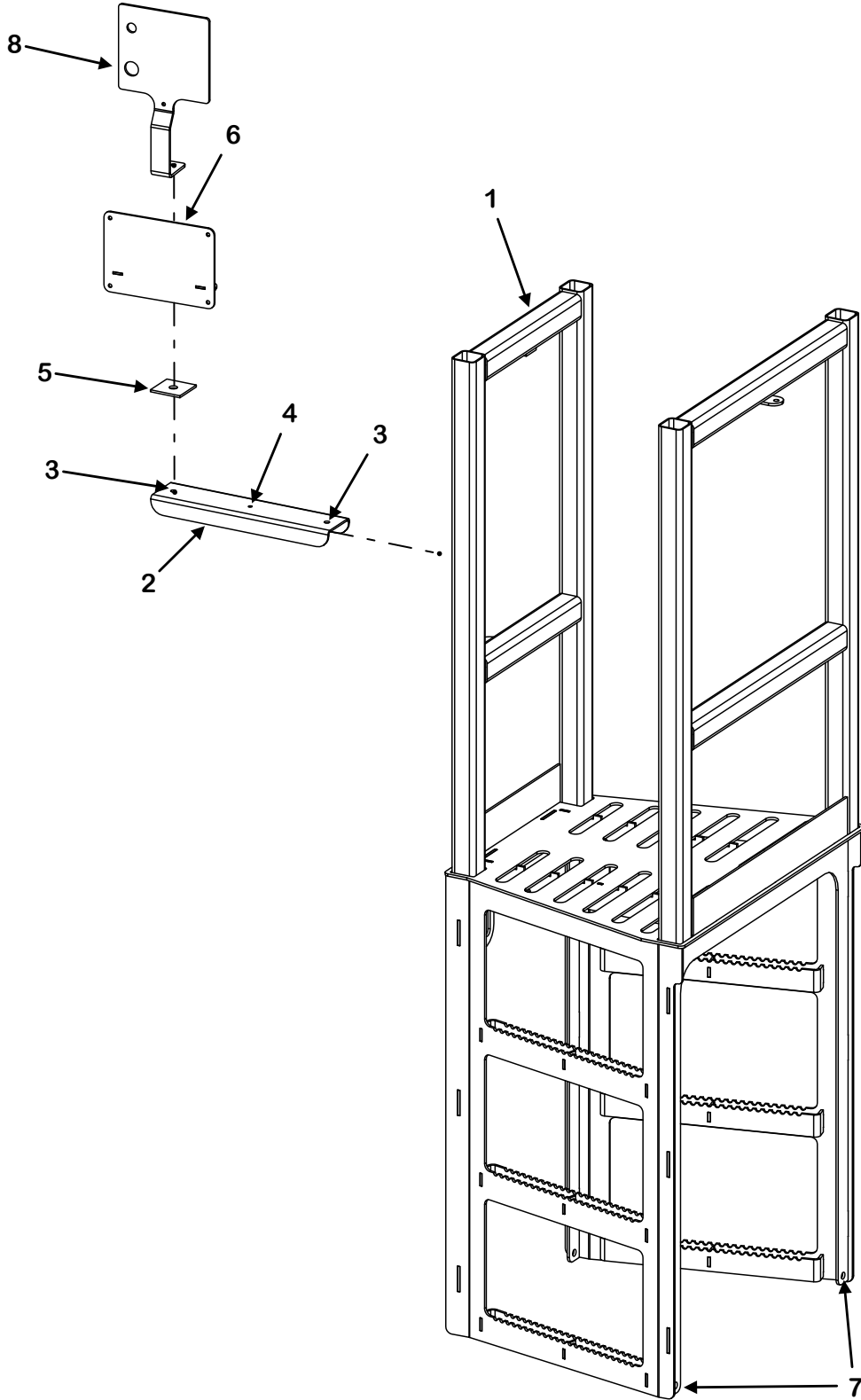

FM-M-0014-1

KEY	PART NUMBER	QTY	DESCRIPTION	MIXER MODEL
1	M10-1-8-0006	1	Viewing Platform Weldment, Single Axle	815
	M10-1-8-0007	1	Viewing Platform Weldment, Tandem Axle	815
	M10-1-10-0006	1	Viewing Platform Weldment, Single Axle	1015
	M10-1-10-0005	1	Viewing Platform Weldment, Tandem Axle	1015
	M10-1-12-0008	1	Viewing Platform Weldment, Single Axle	1215
	M10-1-12-0009	1	Viewing Platform Weldment, Tandem Axle	1215
2	M9-1-8-0003	1	Scale Arm	815 - 1215
3	851-3816-1Z	2	3/8"-16 x 1" Machine Bolt	815 - 1215
	815-3816-Z	2	3/8"-16 Nylon Insert Lock Nut	815 - 1215
4	32-0033	1	1/2" Loom Clamp	815 - 1215
	851-2520-.75Z	1	1/4"-20 x 3/4" Machine Bolt	815 - 1215
	815-2520-Z	1	1/4"-20 Nylon Insert Locknut	815 - 1215
5	M9-1-8-0004	2	Scale Arm Rubber Washer	815 - 1215
6	M9-1-8-0002	1	Scale Indicator Mount	815 - 1215
7	810-5013-Z	4	1/2" Spin Lock Nut	815 - 1215
	851-5013-1.25Z	4	1/2"-13 x 1-1/4" Machine Bolt	815 - 1215
8	MN11-1-0002-3	1	Indicator Light Bracket (Power Shift Models Only)	815 - 1215

AUGER

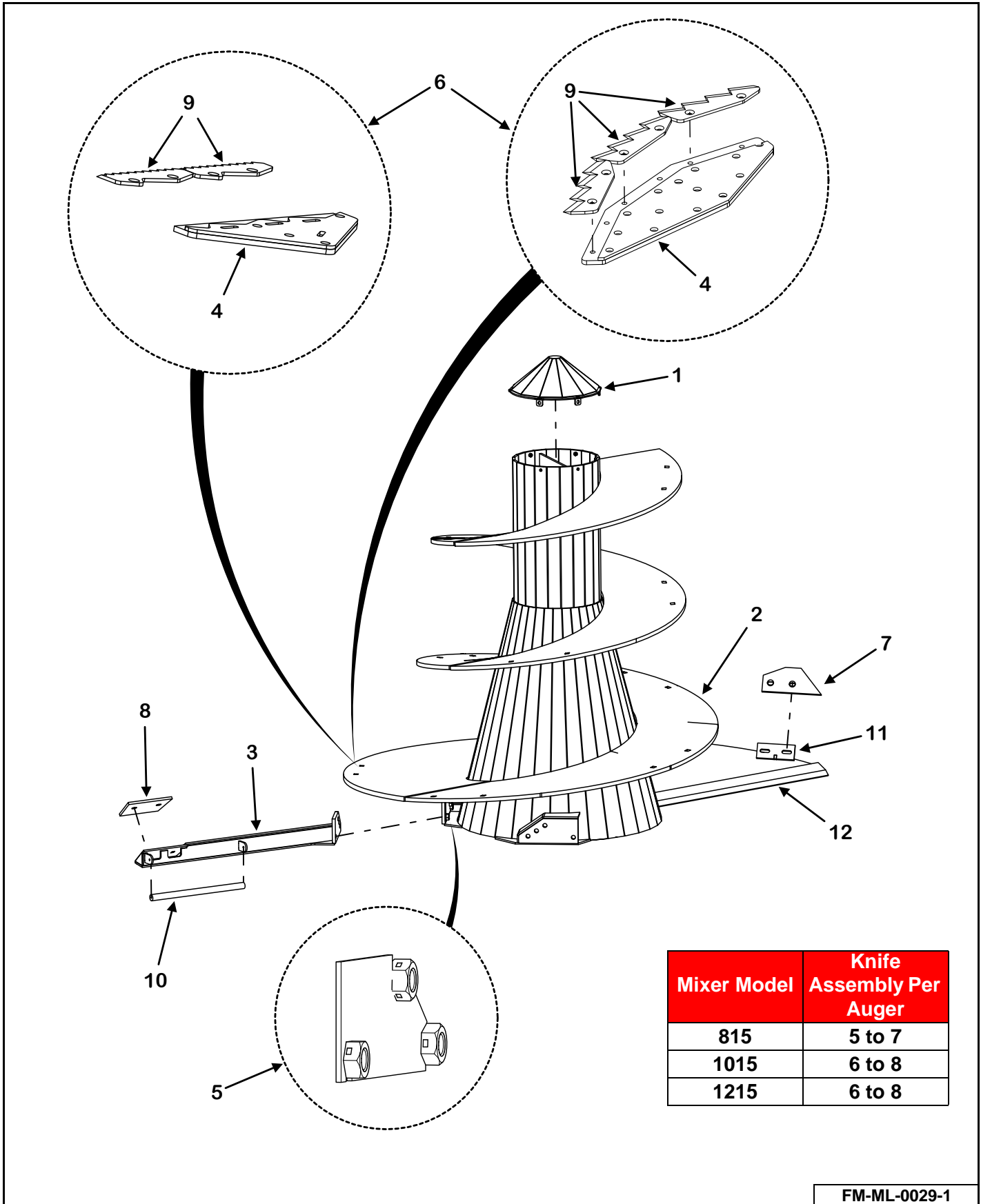

Mixer Model	Knife Assembly Per Auger
815	5 to 7
1015	6 to 8
1215	6 to 8

FM-ML-0029-1

KEY	PART NUMBER	QTY	DESCRIPTION	MIXER MODEL
0	M5-1-8-0020	2	Auger Assembly, Complete With Knives, Backer & Hardware	815
	M5-1-8-0021	2	Stainless Lined Auger Assembly, Complete With Knives, Backer & Hardware (Optional)	815
	M5-1-8-0019	2	Auger Assembly, Complete With Knives, Backer & Hardware (Stop & Shift Models)	815P/815C
	M5-1-8-0022	2	Auger Assembly, Complete With Knives, Backer & Hardware (Power Shift Models)	815P/815C
	M5-1-10-0008	2	Auger Assembly, Complete With Knives, Backer & Hardware	1015
	M5-1-10-0009	2	Stainless Lined Auger Assembly, Complete With Knives, Backer & Hardware (Optional)	1015
	M5-1-10-0007	2	Auger Assembly, Complete With Knives, Backer & Hardware (Stop & Shift Models)	1015P/1015C
	M5-1-10-0010	2	Auger Assembly, Complete With Knives, Backer & Hardware (Power Shift Models)	1015P/1015C
	M5-1-12-0009	2	Auger Assembly, Complete With Knives, Backer & Hardware (Stop & Shift Models)	1215
	M5-1-12-0010	2	Auger Assembly, Complete With Knives, Backer & Hardware (Power Shift Models)	1215
1	M5-1-8-0002	2	Auger Top Cap Weldment	815 - 1215
	851-3118-1.25SS	6 per	5/16"-18 x 1-1/4" Stainless Steel Bolts	815 - 1215
	805-0031-Z	6 per	5/16" Flat Washer	815 - 1215
	822-0031-Z	6 per	5/16" Split Lock Washer	815 - 1215
2	M5-1-8-0020-1	2	Auger Weldment	815
	M5-1-8-0019-1	2	Auger Weldment (Stop & Shift Models)	815P/815C
	M5-1-8-0022-1	2	Auger Weldment (Power Shift Models)	815P/815C
	M5-1-10-0008-1	2	Auger Weldment	1015
	M5-1-10-0007-1	2	Auger Weldment (Stop & Shift Models)	1015P/1015C
	M5-1-10-0010-1	2	Auger Weldment (Power Shift Models)	1015P/1015C
	M5-1-12-0009-1	2	Auger Weldment (Stop & Shift Models)	1215
	M5-1-12-0010-1	2	Auger Weldment (Power Shift Models)	1215
3	M5-1-8-0014	2	Kicker Weldment	815 - 1215
	VAL-AKM-K	2	Kicker Weldment With Magnet Kit	815 - 1215
	881-6311-1.75Z	4	5/8"-11 x 1-3/4" Bolt	815 - 1215

AUGER (CONT'D)

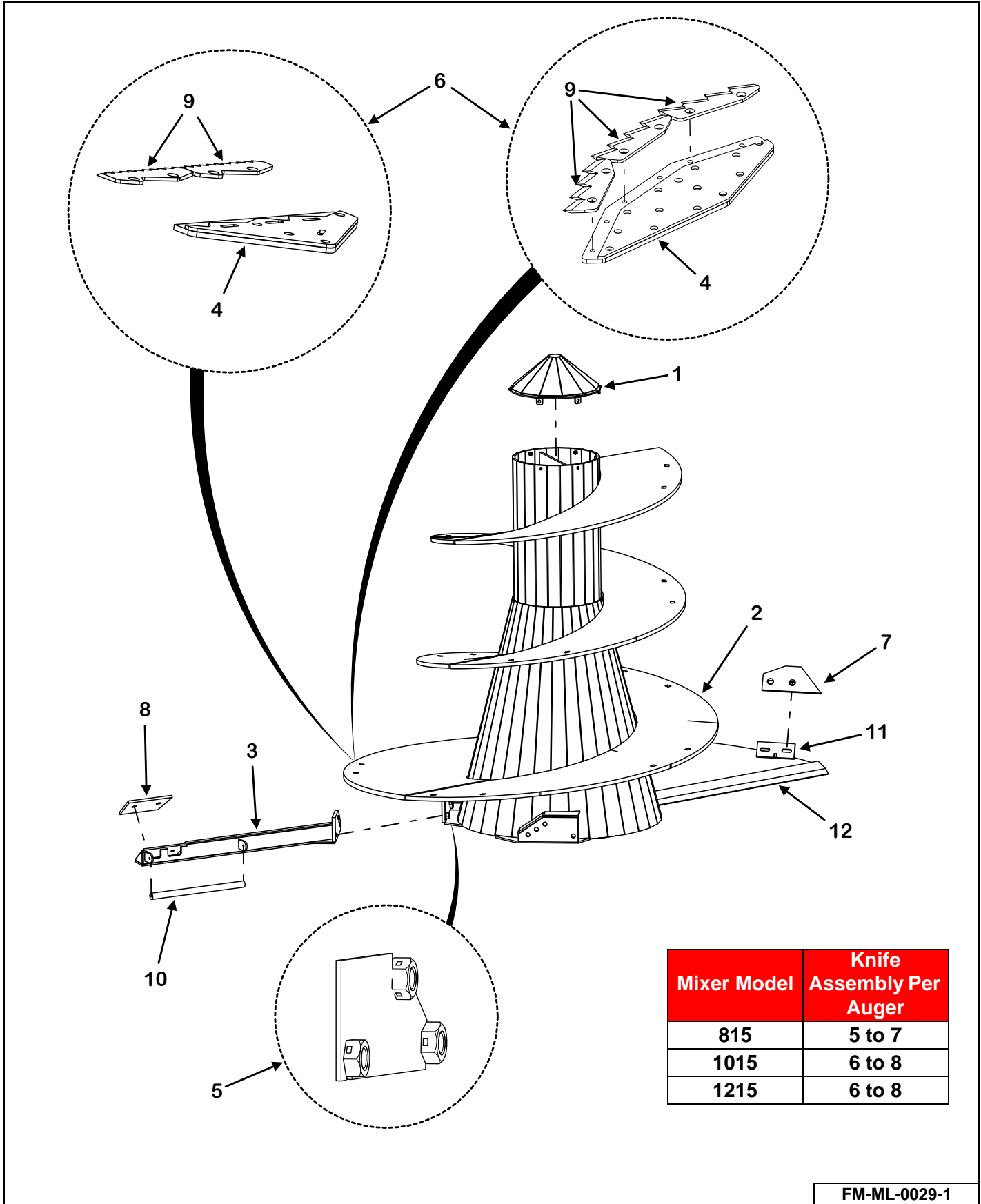

FM-ML-0029-1

KEY	PART NUMBER	QTY	DESCRIPTION	MIXER MODEL
4	M11-1-0040	AR	2-Knife Backer Weldment For Knives	815 - 1215
	M11-1-0041	AR	2-Knife HD Backer Weldment For Knives	815 - 1215
	M11-1-0048	AR	3-Knife Backer Weldment For Knives	815 - 1215
	880-6311-2Z	1 per	5/8"-11 x 2" Carriage Bolt Zinc	815 - 1215
	880-6311-2.5Z	1 per	5/8"-11 x 2" Carriage Bolt Zinc	815 - 1215
	886-6311-Z	2 per	5/8"-11 Center Lock Nut	815 - 1215
5	M5-1-8-0007	2	Auger Kicker Nut Holder Weldment	815 - 1215
6	M11-1-0059-K	AR	Mixer 2-Knife Assembly (Includes Knives, Backers & Hardware)	815 - 1215
	M11-1-0060-K	AR	Mixer 2-Knife With Doubler Assembly (Includes Knives, Backers & Hardware)	815 - 1215
	M11-1-0054-K	AR	Mixer 3-Knife Assembly (Includes Knives, Backers & Hardware)	815 - 1215
7	M5-1-8-0005-K	2	Auger Scraper With Hardware	815 - 1215
	852-5013-1.75Z	2 per	1/2"-13 x 1-3/4" Flat Head Socket Cap Screw	815 - 1215
	815-5013-Z	2 per	1/2"-13 Nylon Lock Nut	815 - 1215
	828-0050-Z	2 per	1/2" SAE Washer	815 - 1215
8	M5-1-8-0006-K	2	Kicker Wear Plate With Hardware	815 - 1215
	852-5013-1.75Z	2 per	1/2"-13 x 1-3/4" Flat Head Socket Cap Screw	815 - 1215
	815-5013-Z	2 per	1/2"-13 Nylon Lock Nut	815 - 1215
	828-0050-Z	2 per	1/2" SAE Washer	815 - 1215
9	M11-1-0050-K	AR	One Blade With Hardware	815 - 1215
	803-3816-1Z	2 per	3/8"-16 x 1" Flat Head Socket Cap Screw	815 - 1215
	814-3816-Z	2 per	3/8"-16 Center Lock Nut	815 - 1215
10	VAL-AKM-K	2	Kicker Weldment With Magnet Kit (Prior to 2021 Model Year)	815 - 1215
	M3-1-8-0020-4	AR	Kicker Magnet (2021 Model Year & Later)	815 - 1215
	851-2520-.75Z	2 per	1/4"-20 x 3/4" Hex Cap Screw	815 - 1215
	822-0025-Z	2 per	1/4" Split Lock Washer	815 - 1215
11	M5-1-8-0001-1-13	2	Scraper Mount (Welded On)	815 - 1215
	M5-1-8-0001-1-14	2	Scraper Mount Gusset (Welded On)	815 - 1215
12	M5-1-10-0001-1-6	2	Auger Lead Edge (Welded On)	815 - 1215

STOP & SHIFT DRIVELINE

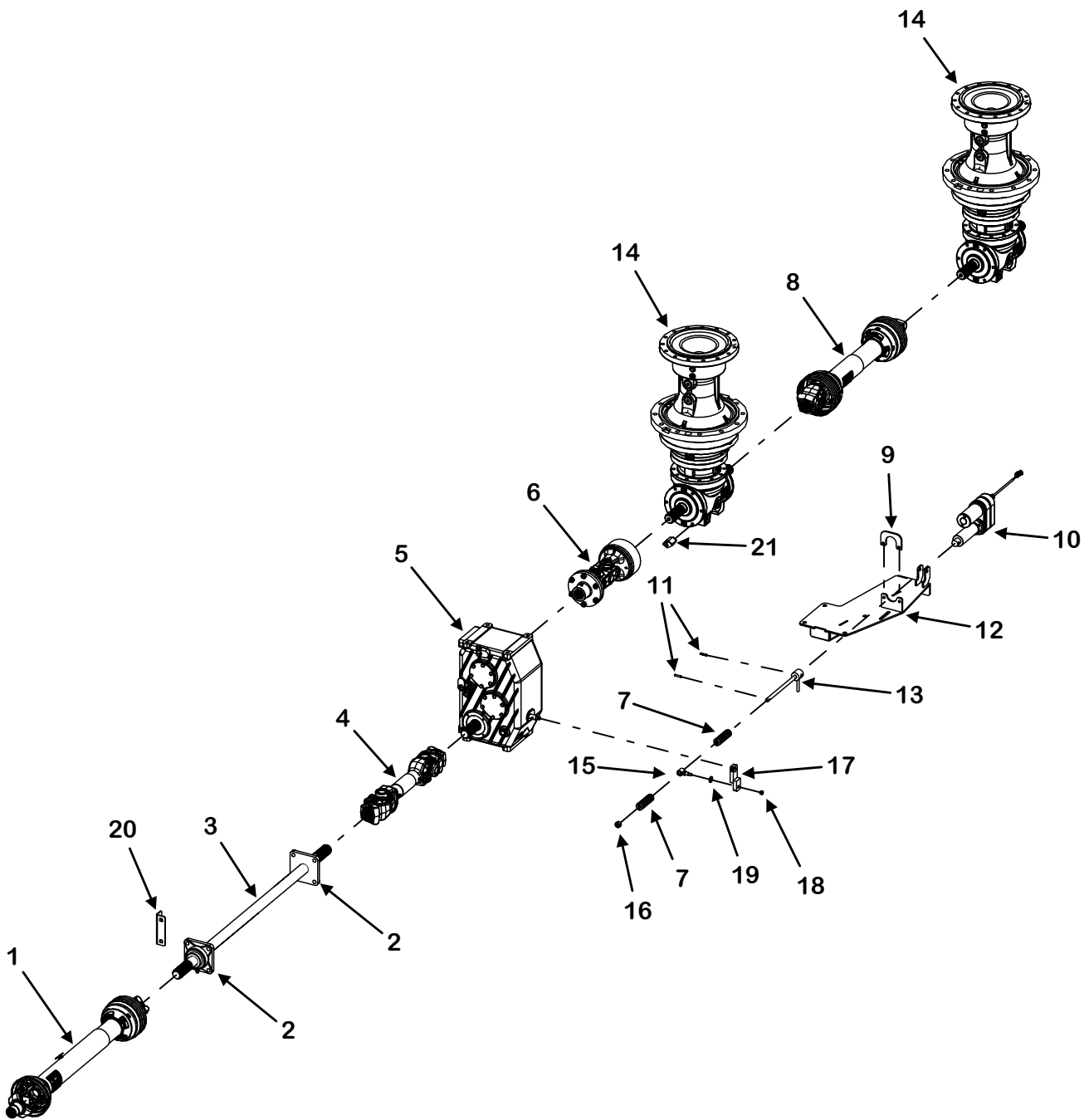

FM-ML-0030-1

KEY	PART NUMBER	QTY	DESCRIPTION	MIXER MODEL
1	See Page 198	1	1-3/8"-21 Spline PTO Complete	815 - 1215
	See Page 200	1	1-3/4"-20 Spline Tractor Half PTO (Optional)	815 - 1215
2	914-3819	2	1-3/4" 4-Bolt Bearing	815 - 1215
3	123-1.75-0014	1	PTO Extension Drive Shaft, Front Discharge	815/1015
	123-1.75-0015	1	PTO Extension Drive Shaft, Side Discharge	815/1015
	123-1.75-0014	1	PTO Extension Drive Shaft, Front Discharge (Prior to SN 21VM1015205)	1015P
	123-1.75-0015	1	PTO Extension Drive Shaft, Side Discharge (Prior to SN 21VM1015205)	1015P
	123-1.75-0019	1	PTO Extension Drive Shaft, Front Discharge (1015P SN 21VM1015205 & Later)	815P/815C/ 1015P/1015C/ 1215
	123-1.75-0013	1	PTO Extension Drive Shaft, Side Discharge (1015P SN 21VM1015205 & Later)	815P/815C/ 1015P/1015C/ 1215
4	See Page 206	1	1-3/4"-20 Spline PTO Complete	815 - 1215
5	See Page 172	1	2-Speed Shifting Gearbox 1.00:1/1.50:1 1.75-20 Spline	815/1015
	See Page 172	1	2-Speed Shifting Gearbox 1.00:1/1.50:1 1.75-20 Spline (Prior to SN 21VM1015205)	1015P
	See Page 176	1	2-Speed Shifting Gearbox 1.00:1/1.50:1 1.75-20 Spline (1015P SN 21VM1015205 & Later)	815P/815C/ 1015P/1015C/ 1215
6	See Page 207	1	Double Universal Joint W/Cutout Clutch	815 - 1215
7	29-0036	2	2-Speed Die Spring	815 - 1215
8	See Page 210	1	Planetary to Planetary Drive Shaft	815 - 1215
9	M11-2-0001-4	1	2-Speed Top Cylinder Mount	815 - 1215
10	56-0123	1	12V Linear Actuator With Plug	815 - 1215
11	38-0003	2	1/4" x 1-1/4" Roll Pin	815 - 1215
12	M11-2-0011	1	2-Speed Shift Mount Weldment	815/1015
	M11-2-0011	1	2-Speed Shift Mount Weldment (Prior to SN 21VM1015205)	1015P
	M11-13-0001	1	2-Speed Shift Mount Weldment (1015P SN 21VM1015205 & Later)	815P/815C/ 1015P/1015C/ 1215
13	M11-2-0003	1	2-Speed Shift Rod Weldment	815 - 1215

STOP & SHIFT DRIVELINE (CONT'D)

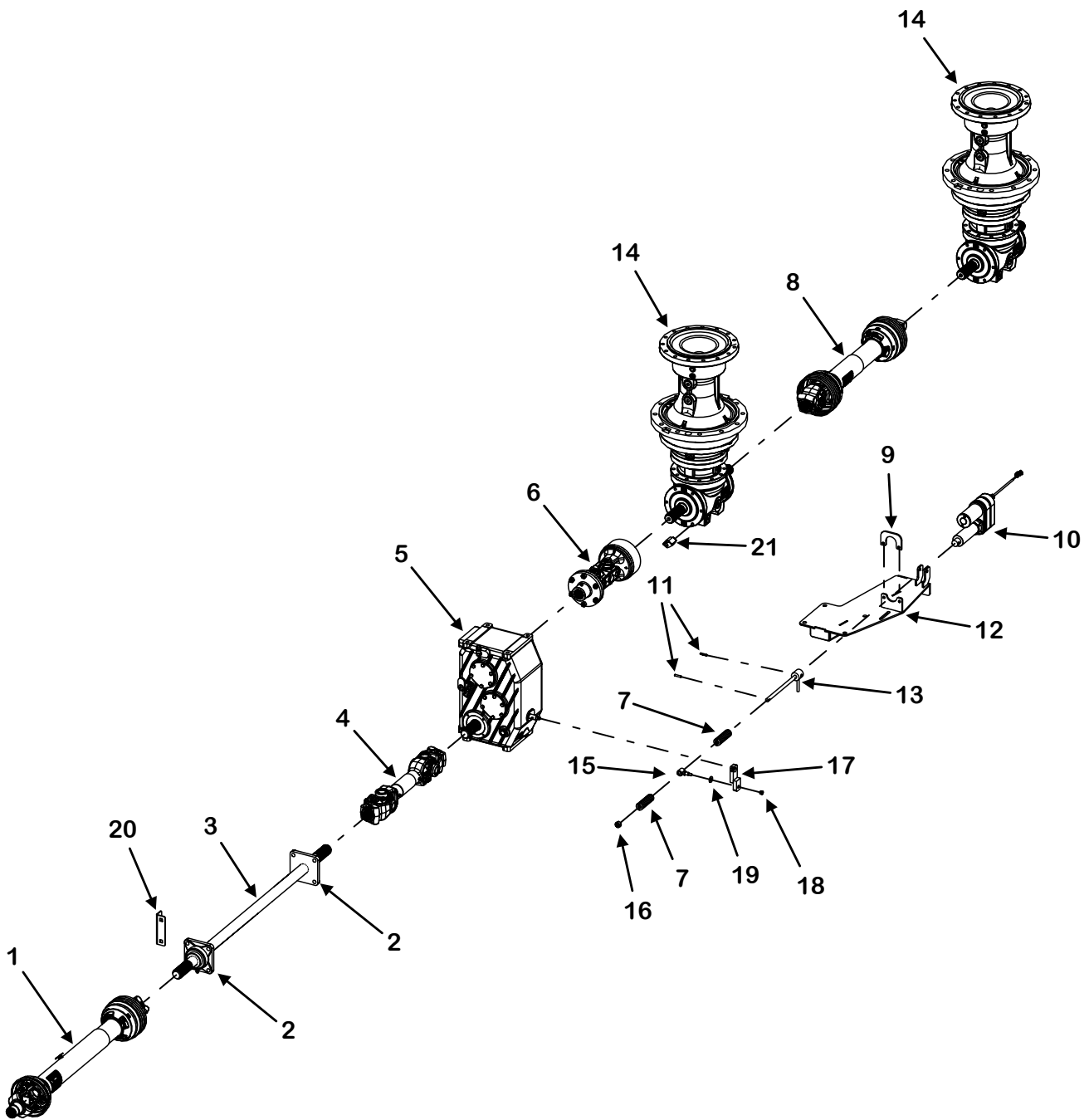

FM-ML-0030-1

KEY	PART NUMBER	QTY	DESCRIPTION	MIXER MODEL
14	See Page 186	2	2100 Series Planetary Gearbox	815/1015
	851-6311-2.5Z	24	5/8"-11 x 2-1/2" Machine Bolt	815/1015
	814-6311-Z	24	5/8"-11 Indented Lock Nut	815/1015
	See Page 188	2	3200 Series Planetary Gearbox	815P/815C/ 1015P/1015C/ 1215
	851-M22-2.5-80-Z	24	M22-2.5 x 80mm Machine Bolt	815P/815C/ 1015P/1015C/ 1215
	815-M22-2.5-Z	24	M22-2.5 Nylon Insert Lock Nut	815P/815C/ 1015P/1015C/ 1215
15	M11-13-0006	1	Shift Pivot Tube Weldment	815/1015
	M11-13-0006	1	Shift Pivot Tube Weldment (Prior to SN 21VM1015205)	1015P
	M11-13-0004-2	1	Shift Pivot Tube Weldment (1015P SN 21VM1015205 & Later)	815P/815C/ 1015P/1015C/ 1215
16	814-5612-Z	1	9/16"-12 Indented Lock Nut	815 - 1215
17	M11-13-0005	1	Shifter Arm Weldment	815/1015
	M11-13-0005	1	Shifter Arm Weldment (Prior to SN 21VM1015205)	1015P
	M11-13-0004-1	1	Shifter Arm (1015P SN 21VM1015205 & Later)	815P/815C/ 1015P/1015C/ 1215
18	814-3816-Z	1	3/8"-16 Indented Lock Nut	815 - 1215
19	M11-13-0004-3	1	Spacer	815 - 1215
20	M9-1-7-0001	1	Shaft Rotation Sensor Bracket	815 - 1215
21	M9-1-8-0011	1	Planetary Rotation Counter Bracket	815 - 1215

POWER SHIFT DRIVELINE

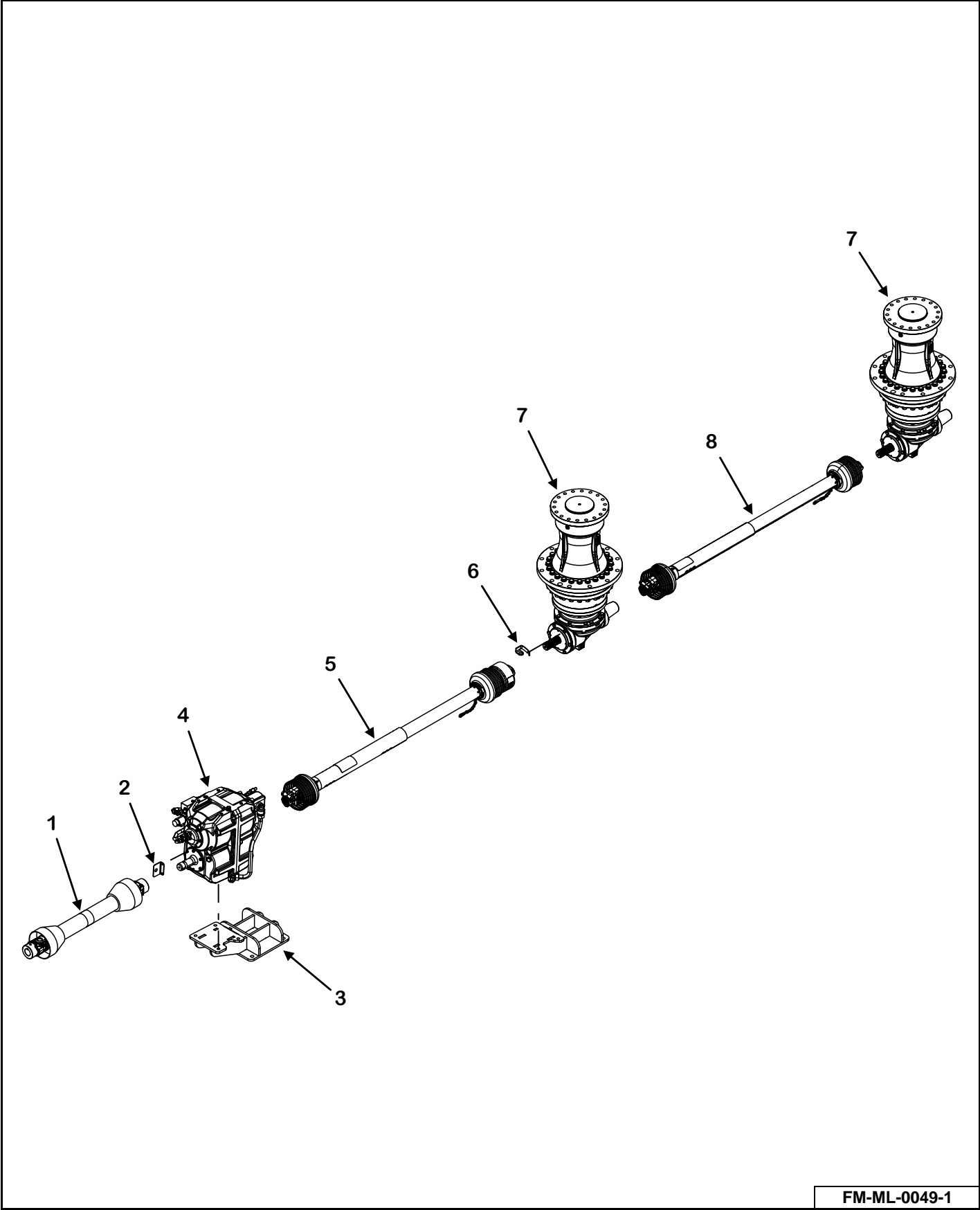

FM-ML-0049-1

KEY	PART NUMBER	QTY	DESCRIPTION	MIXER MODEL
1	See Page 198	1	1-3/8"-21 Spline PTO Complete	815 - 1215
2	MN11-1-0002-2	1	Speed Switch Mount Plate	815 - 1215
3	See Pages 90 & 94	1	Power Shift Transmission Mount	815 - 1215
4	See Pages 182 & 184	1	Zuidberg 2-Speed Automatic Transmission	815 - 1215
5	See Page 202	1	1-3/4"-20 Spline PTO Prior to SN 25VM(0815201, 1015203, 1215201)	815 - 1215
	See Page 204	1	1-3/4"-20 Spline PTO SN 25VM(0815201, 1015203, 1215201) & Later	815 - 1215
6	M9-1-8-0011	1	Rotation Counter Bracket	815 - 1215
7	See Page 188	2	3200 Series Planetary Gearbox	815 - 1215
8	See Page 210	1	1-3/4"-20 Spline PTO	815 - 1215

815 / 1015 / 1015P STOP & SHIFT GEARBOX
 (1015P PRIOR TO SN 21VM1015205)

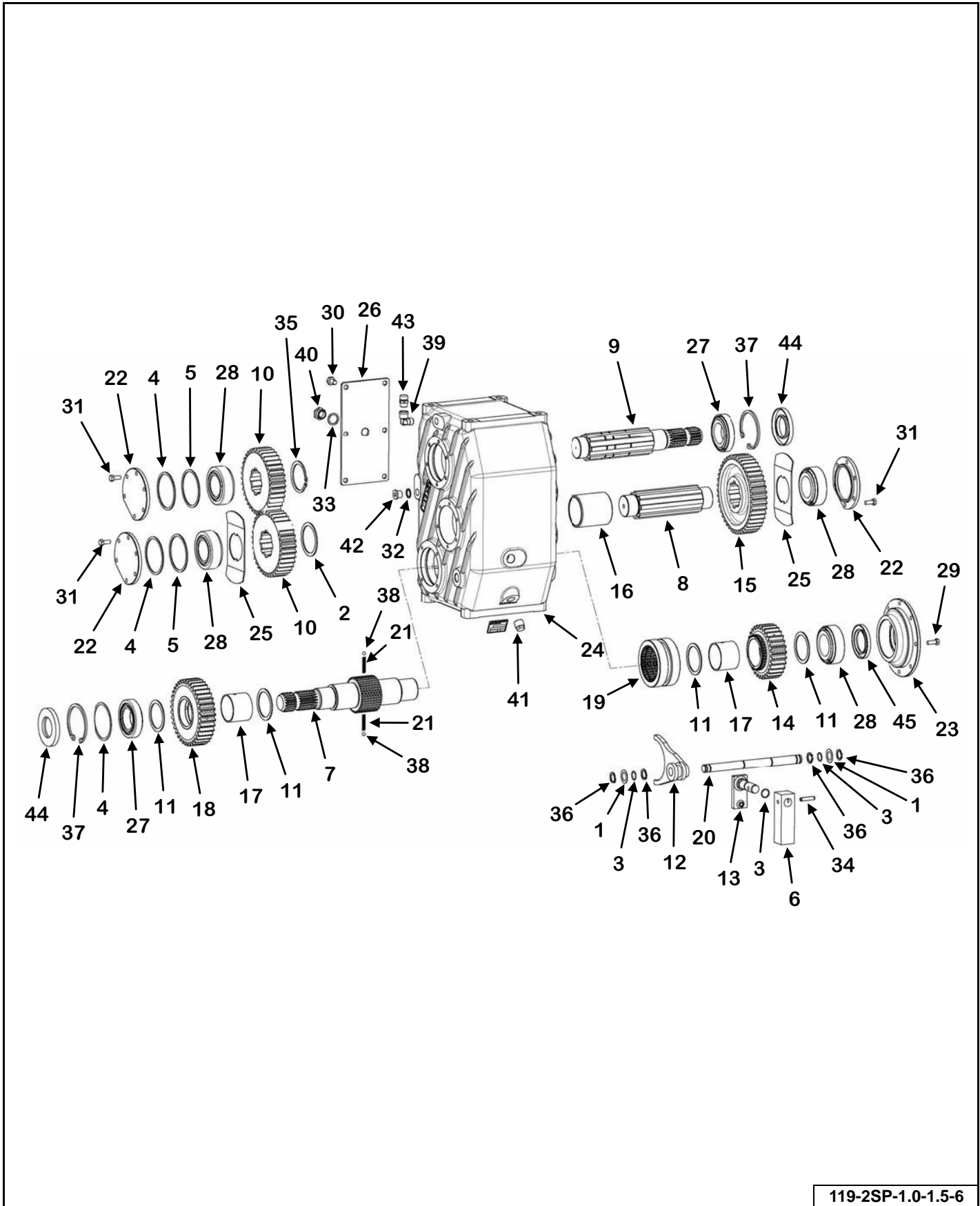

119-2SP-1.0-1.5-6

KEY	PART NUMBER	QTY	DESCRIPTION
0	119-2SP-1.0-1.5-6K	1	2-Speed Shifting Gearbox 1.00:1/1.50:1 1.75-20 Spline
1	119-2SP-C-1	2	Shim Kit
2	119-2SP-C-83	1	Shim
3	119-2SP-C-74	3	O-Ring
4	119-2SP-C-85	3	Shim Kit
5	119-2SP-C-86	2	Shim
6	119-2SP-C-30	1	Outer Lever
7	119-2SP-C-87	1	Shaft
8	119-2SP-C-88	1	Middle Shaft
9	119-2SP-C-89	1	Shaft
10	119-2SP-C-90	2	Gear
11	119-2SP-C-91	4	Thrust Washer
12	119-2SP-C-92	1	Fork
13	119-2SP-C-93	1	Inner Lever
14	119-2SP-C-94	1	Gear
15	119-2SP-C-95	1	Crown Wheel
16	119-2SP-C-96	1	Spacer
17	119-2SP-C-97	2	Bushing
18	119-2SP-C-98	1	Gear
19	119-2SP-C-99	1	Slide Gear
20	119-2SP-C-100	1	Gear Selector Rod
21	119-2SP-C-101	2	Spring
22	119-2SP-C-102	3	Cover
23	119-2SP-C-103	1	Cover
24	119-2SP-C-104	1	Casing
25	119-2SP-C-105	2	Lubricating Sheet
26	119-2SP-C-106	1	Cover
27	119-2SP-C-107	2	Roller Bearing
28	119-2SP-C-108	4	Bearing
29	119-2SP-C-109	8	M8 x 22mm Bolt
30	119-2SP-C-43	6	M10 x 16 Bolt
31	119-2SP-C-110	18	M8 x 20 mm Bolt
32	119-2SP-C-111	1	Aluminum Washer
33	119-2SP-C-46	1	Aluminum Washer
34	119-2SP-C-48	1	Spring Pin

815 / 1015 / 1015P STOP & SHIFT GEARBOX (CONT'D)
(1015P PRIOR TO SN 21VM1015205)

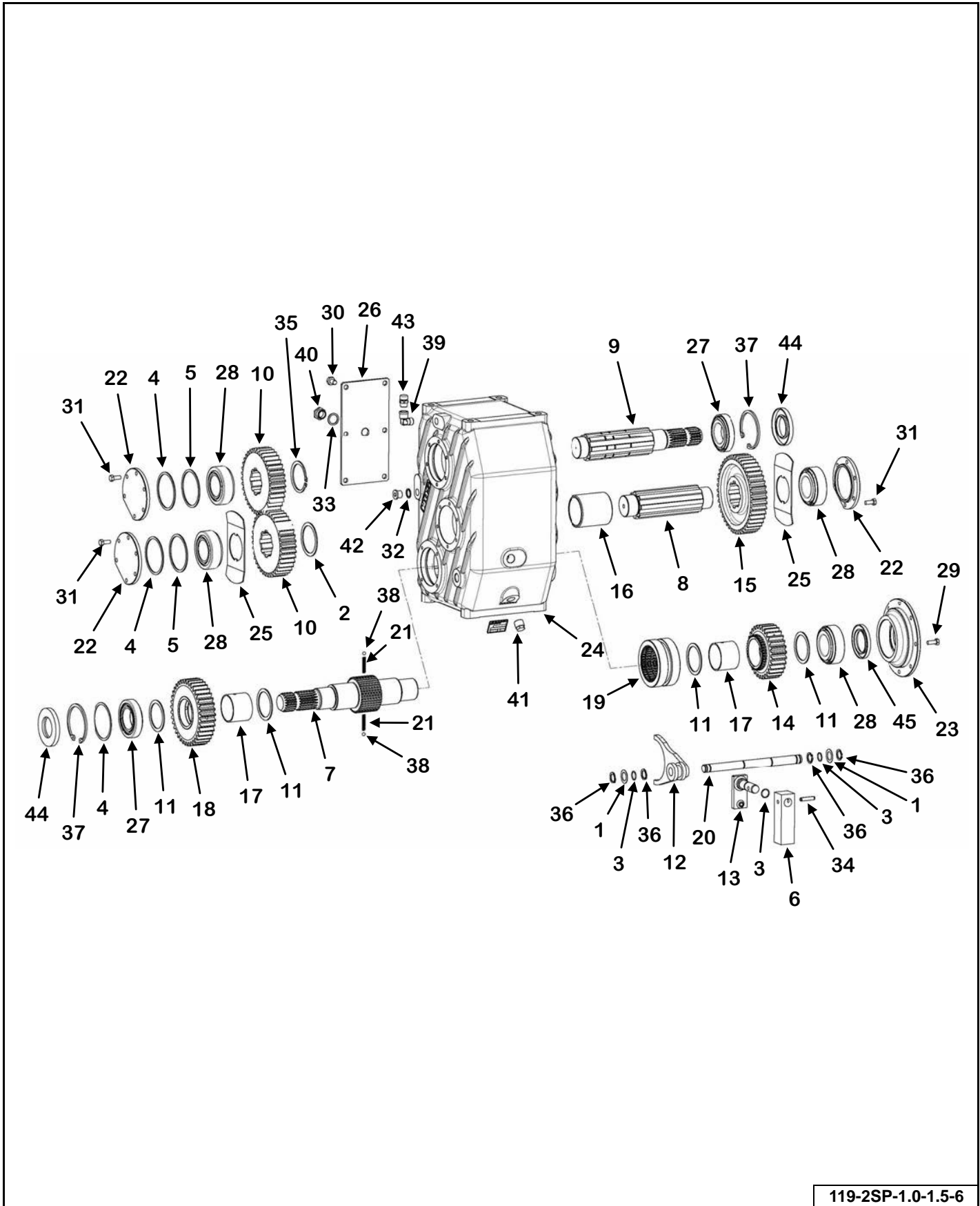

119-2SP-1.0-1.5-6

KEY	PART NUMBER	QTY	DESCRIPTION
35	119-2SP-C-112	1	Snap Ring
36	119-2SP-C-50	4	Snap Ring
37	119-2SP-C-113	2	Snap Ring
38	119-2SP-C-114	2	Ball
39	119-2SP-C-115	1	90° Elbow
40	119-2SP-C-116	1	Oil Level Indicator
41	119-2SP-C-117	1	1/2" Plug
42	119-2SP-C-118	1	3/8" Plug
43	119-2SP-C-119	1	3/8" Breather Plug
44	119-2SP-C-120	2	Double Lip Seal
45	119-2SP-C-121	1	Dust Lip
NS	M11-13-0011	1	Gearbox Pump Cover
	M11-13-0012	1	Gearbox Pump Cover Seal
	851-M10-1.5-20-Z	3	M1-1.5 x 20MM Hex Head Cap Screw

815P / 815C / 1015P / 1015C / 1215 STOP & SHIFT GEARBOX
 (1015P SN 21VM1015205 & LATER)

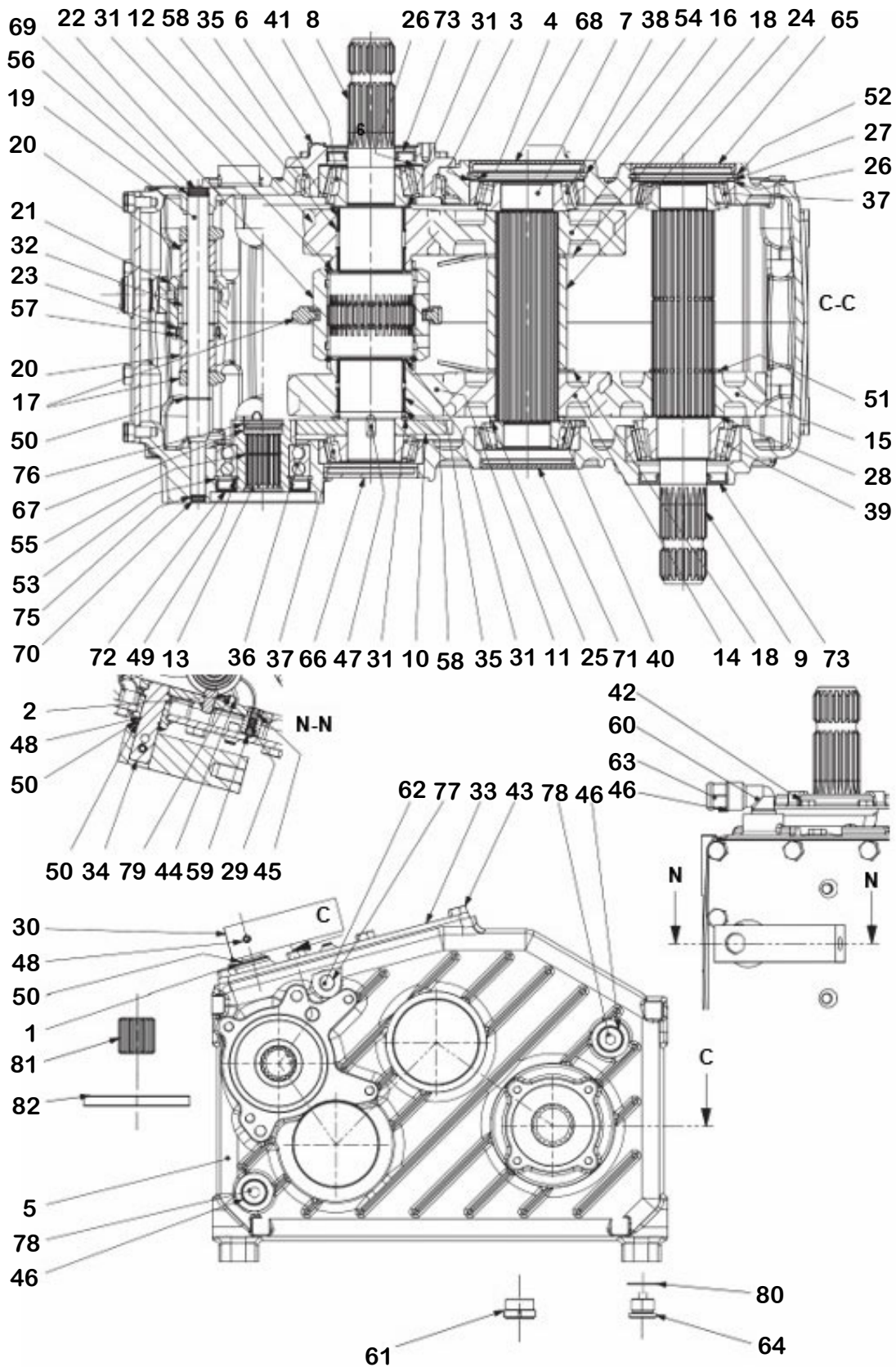

119-2SP-1.0-1.5-9K

KEY	PART NUMBER	QTY	DESCRIPTION
0	119-2SP-1.0-1.5-9K	1	2-Speed Shifting Gearbox 1.00:1/1.50:1 1.75-20 Spline
1	119-2SP-C-1	1	Shim
2	119-2SP-C-2	1	Shim
3	119-2SP-C-3	1	Shim
4	119-2SP-C-4	1	Shim
5	119-2SP-C-5	1	Casing
6	119-2SP-C-6	1	Cover
7	119-2SP-C-7	1	Middle Shaft
8	119-2SP-C-8	1	Input Shaft
9	119-2SP-C-9	1	Output Shaft
10	119-2SP-C-10	1	Pinion
11	119-2SP-C-11	1	Gear
12	119-2SP-C-12	1	Gear
13	119-2SP-C-13	1	Pinion
14	119-2SP-C-14	1	Crown Wheel
15	119-2SP-C-15	1	Crown Wheel
16	119-2SP-C-16	1	Crown Wheel
17	119-2SP-C-17	1	Pivot
18	119-2SP-C-18	2	Lubrication Sheet
19	119-2SP-C-19	1	Gear Selector Rod
20	119-2SP-C-20	2	Slide Gear
21	119-2SP-C-21	1	Slide Gear
22	119-2SP-C-22	1	Slide Gear
23	119-2SP-C-23	1	Spacer
24	119-2SP-C-24	1	Spacer
25	119-2SP-C-25	1	Spacer
26	119-2SP-C-26	2	Shim
27	119-2SP-C-27	1	Shim
28	119-2SP-C-28	1	Shim
29	119-2SP-C-29	1	Spring
30	119-2SP-C-30	1	Outer Lever
31	119-2SP-C-31	4	Thrust Washer
32	119-2SP-C-135	1	Spacer (1015P)
	VAL-IL-ISC-613	1	Gearbox Shift Collar Kit (1015C/1215) Prior to SN 20VM(1015216, 1215206)
	119-2SP-C-135	1	Spacer (1015C/1215) SN 20VM(1015216, 1215206) & Later
33	119-2SP-C-33	1	Cover
34	119-2SP-C-34	1	Inner Lever

815P / 815C / 1015P / 1015C / 1215 STOP & SHIFT GEARBOX (CONT'D)
 (1015P SN 21VM1015205 & LATER)

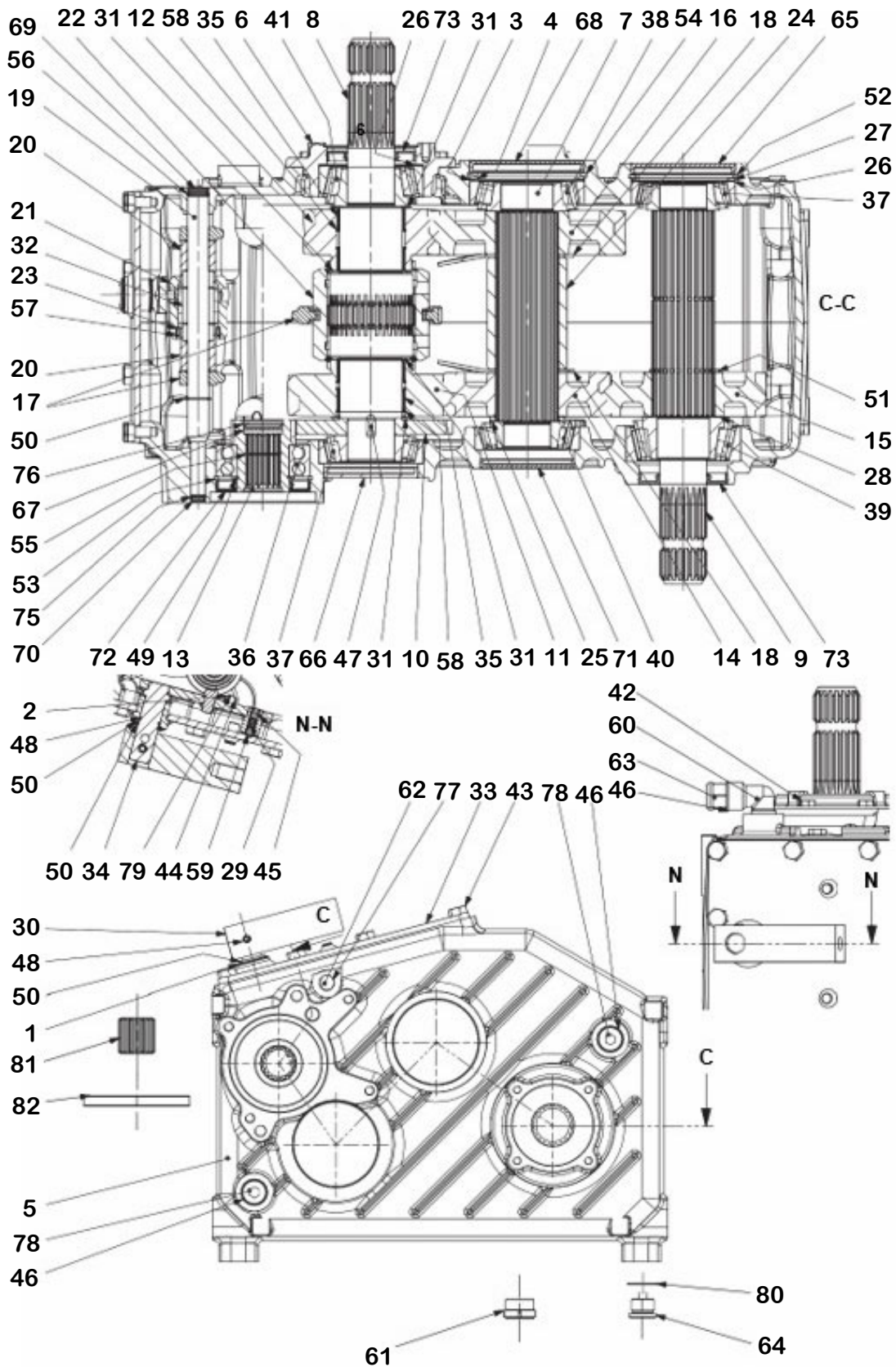

119-2SP-1.0-1.5-9K

KEY	PART NUMBER	QTY	DESCRIPTION
35	119-2SP-C-35	4	Needle Bearing
36	119-2SP-C-36	1	Bearing
37	119-2SP-C-37	2	Bearing
38	119-2SP-C-38	1	Bearing
39	119-2SP-C-39	1	Bearing
40	119-2SP-C-40	1	Bearing
41	119-2SP-C-41	1	Bearing
42	119-2SP-C-42	8	M8 x 25mm Bolt
43	119-2SP-C-43	12	M10 x 16mm Bolt
44	119-2SP-C-44	1	Bolt
45	119-2SP-C-45	1	M8 x 10mm Bolt
46	119-2SP-C-46	3	Aluminum Washer
47	119-2SP-C-47	2	Parallel Key
48	119-2SP-C-48	1	Spring Pin
49	119-2SP-C-49	1	Snap Ring
50	119-2SP-C-50	2	Snap Ring
51	119-2SP-C-51	1	Snap Ring
52	119-2SP-C-52	1	Snap Ring
53	119-2SP-C-53	1	Snap Ring
54	119-2SP-C-54	1	Snap Ring
55	119-2SP-C-55	1	Snap Ring
56	119-2SP-C-56	1	Snap Ring
57	119-2SP-C-57	1	Snap Ring
58	119-2SP-C-58	5	Retention Ring
59	119-2SP-C-59	1	Ball
60	119-2SP-C-60	1	90 Degree Elbow
61	119-2SP-C-61	1	Oil Level Indicator
62	119-2SP-C-62	2	M10 x 1 Plug
63	119-2SP-C-63	1	1/2" Oil Fill Plug
64	119-2SP-C-64	1	1/2" Plug
65	119-2SP-C-65	1	Cap
66	119-2SP-C-66	1	Cap
67	119-2SP-C-67	1	Cap
68	119-2SP-C-68	1	Cap
69	119-2SP-C-69	1	Cap
70	119-2SP-C-70	1	Cap

815P / 815C / 1015P / 1015C / 1215 STOP & SHIFT GEARBOX (CONT'D)
 (1015P SN 21VM1015205 & LATER)

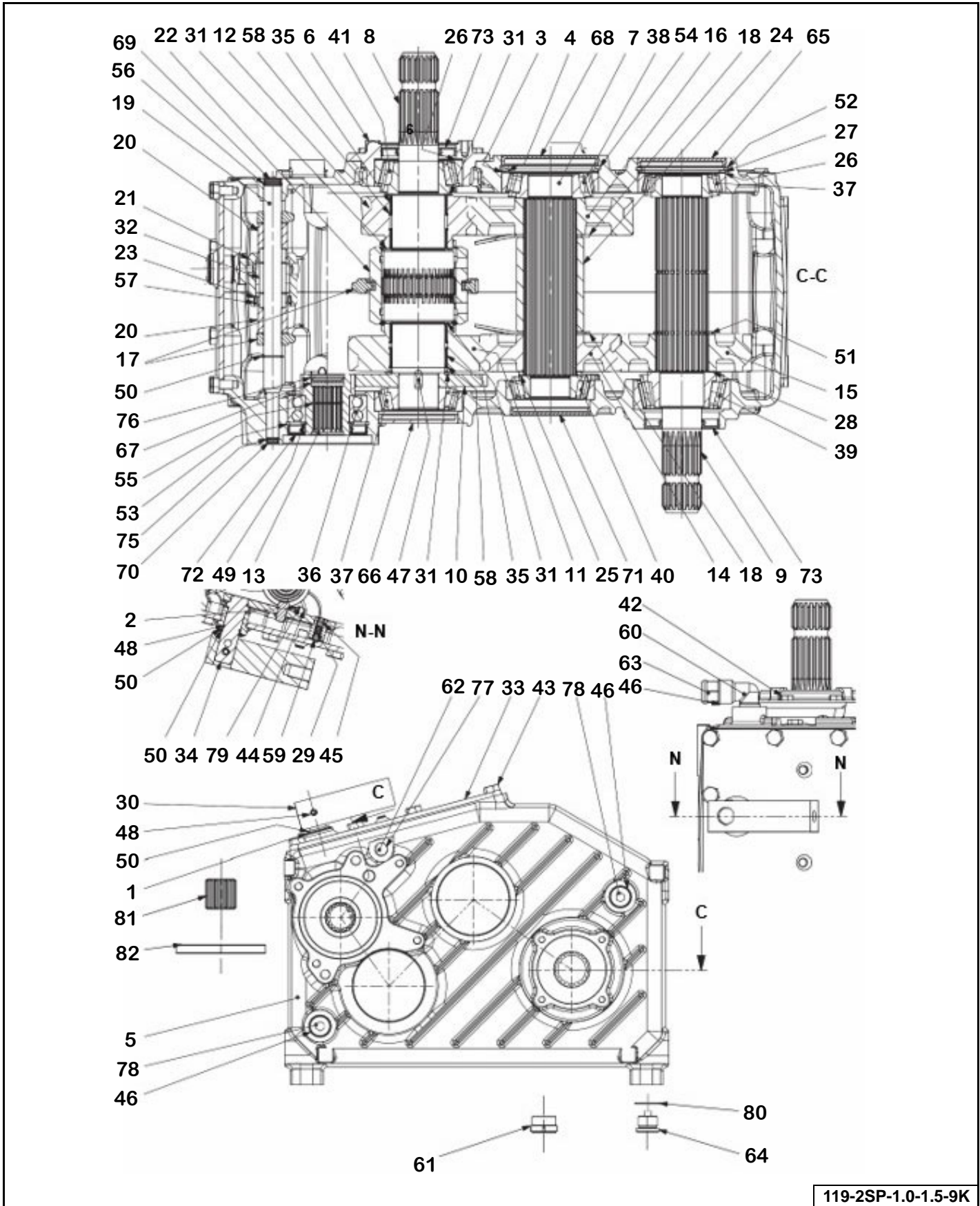

119-2SP-1.0-1.5-9K

KEY	PART NUMBER	QTY	DESCRIPTION
71	119-2SP-C-71	1	Cap
72	119-2SP-C-72	1	Double Lip Seal
73	119-2SP-C-73	2	Double Lip Seal
74	119-2SP-C-74	1	O-Ring
75	119-2SP-C-75	1	C-Clip
76	119-2SP-C-76	1	Internal Snap Ring
77	119-2SP-C-77	2	Copper Washer
78	119-2SP-C-78	2	1/2" Plug
79	119-2SP-C-79	1	Lock Nut
80	119-2SP-C-80	1	Copper Washer
81	119-2SP-C-81	1	Joint
82	119-2SP-C-82	1	Plate
NS	M11-13-0010	1	Gearbox Pump Cover
	822-M12-Z	2	M12 Split Lock Washer
	851-M12-1.75-20-Z	2	M12-1.75 x 20MM Hex Head Cap Screw
NS	VAL-IL-ISC-613	1	Collar Kit

815 / 1015 / 1215 POWER SHIFT TRANSMISSION (EXTERNALS)

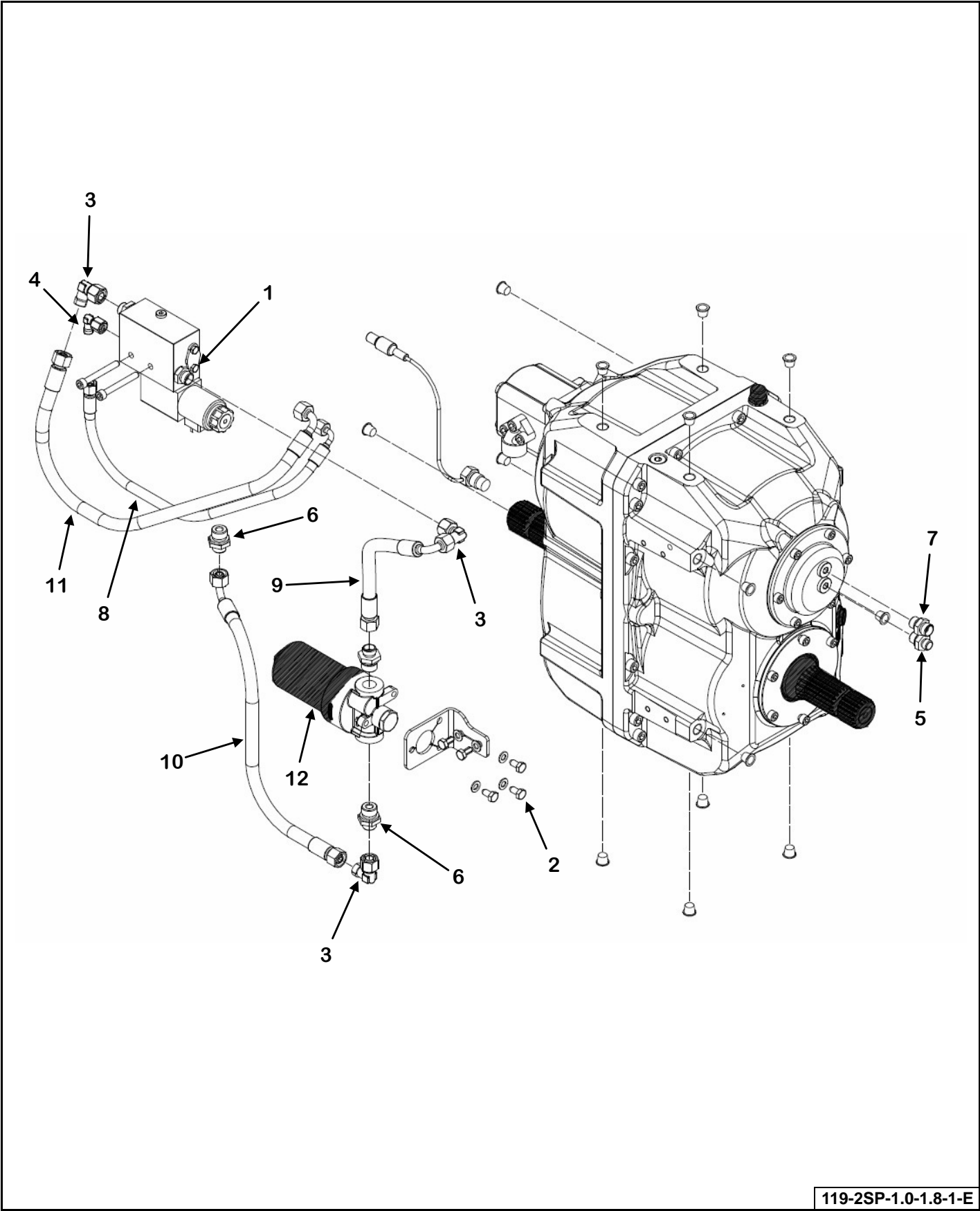

119-2SP-1.0-1.8-1-E

KEY	PART NUMBER	QTY	DESCRIPTION
0	119-2SP-1.0-1.8-1	1	Zuidberg 2-Speed Automatic Transmission
	119-Z-14	1	Clutch Service Kit (Includes Steels, Frictions, Seals, Springs, & Pins)
1	119-Z-04	1	Hydraulic Valve Block
2	851-M8-1.25-16-Z	5	M8-1.25 x 16mm Hex Cap Screw
3	119-Z-05	3	90° Elbow
4	119-Z-06	1	90° Elbow
5	119-Z-07	1	Straight Adapter
6	119-Z-08	1	Straight Adapter
7	119-Z-09	1	Straight Adapter
8	119-Z-10	1	Hose
9	119-Z-11	1	Hose
10	119-Z-12	1	Hose
11	119-Z-13	1	Hose
12	119-Z-01	1	Filter Housing With Filter Element
	119-Z-01-1	1	Filter Element Only

POWER SHIFT TRANSMISSION (INTERNALS)

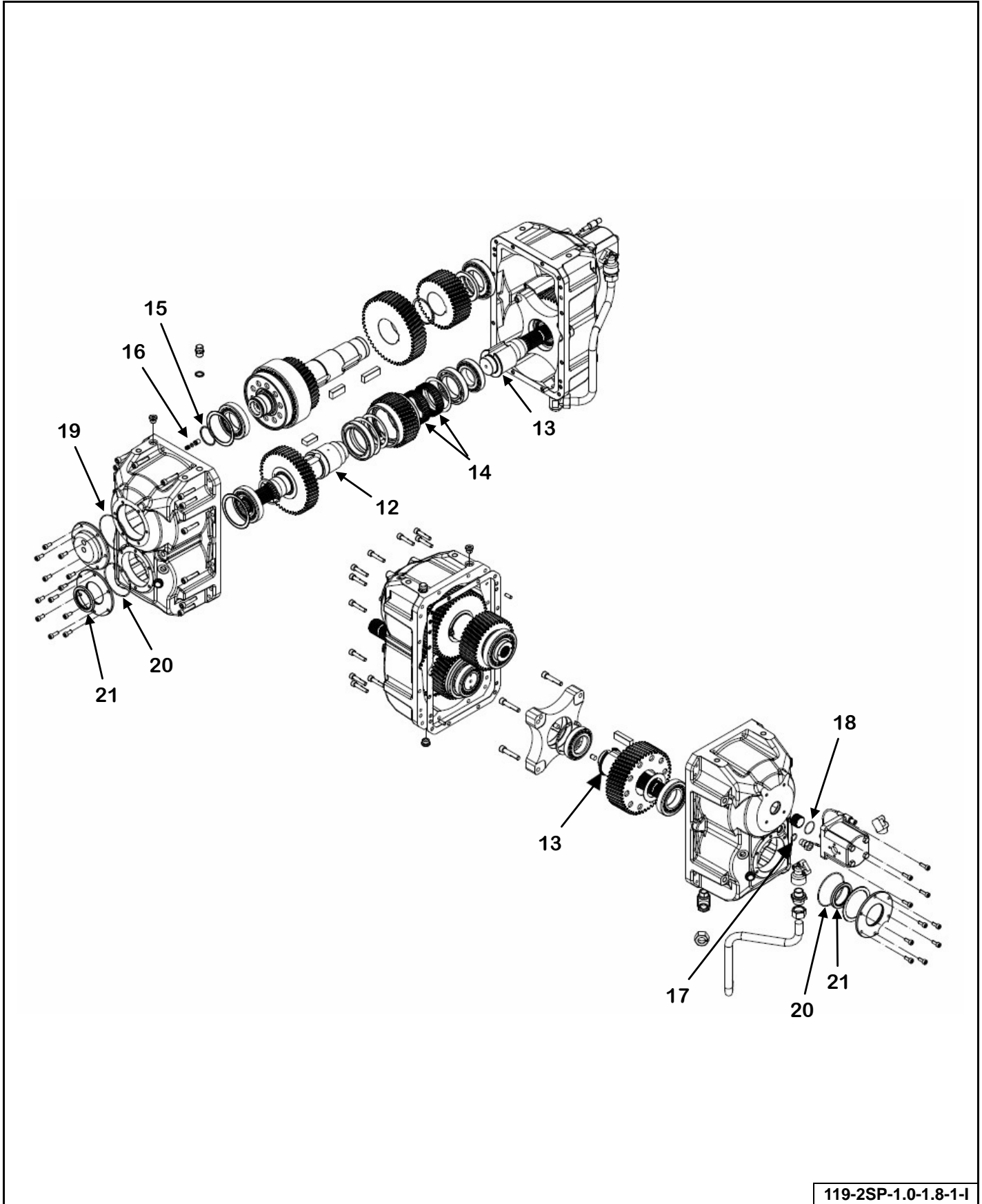

119-2SP-1.0-1.8-1-I

KEY	PART NUMBER	QTY	DESCRIPTION
12	119-Z-15	1	Shaft
13	119-Z-16	1	Shaft
14	119-Z-17	2	Ratchet Overrun Bearing
15	119-Z-18	1	Piston Ring
16	119-Z-19	1	O-Ring
17	119-Z-20	1	O-Ring
18	119-Z-21	1	O-Ring
19	119-Z-22	1	O-Ring
20	119-Z-23	2	O-Ring
21	119-Z-24	2	Oil Seal

2100 SERIES PLANETARY
MODELS: 815 / 1015

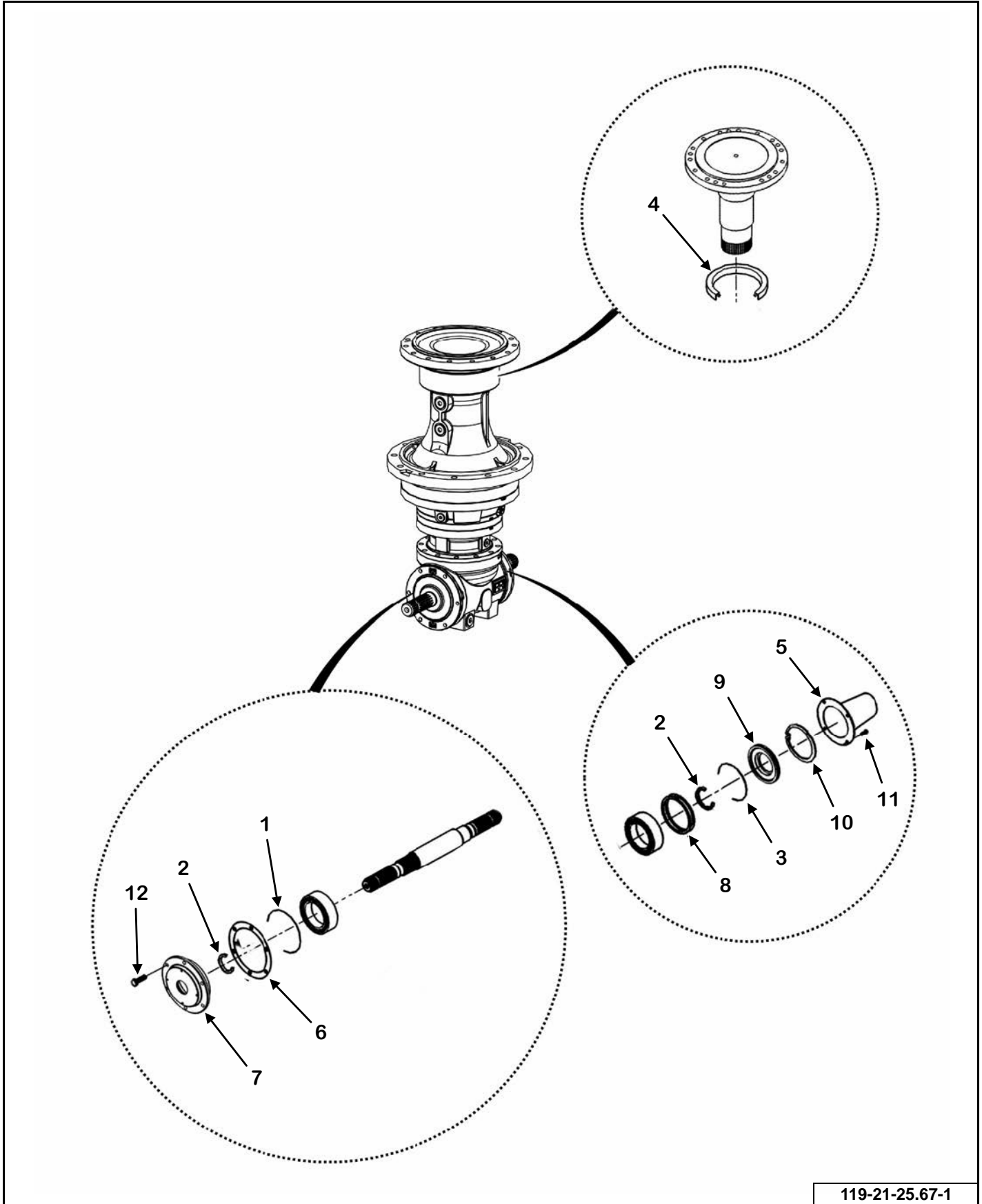

119-21-25.67-1

KEY	PART NUMBER	QTY	DESCRIPTION
0	119-21-25.67-1	2	2100 Series Planetary Gearbox
1	119-P-RR-5	1	O-Ring
2	119-P-RR-6	2	Oil Seal
3	119-P-RR-7	1	O-Ring
4	119-P-RR-1	1	Oil Seal
5	119-P-RR-13	1	Shaft Protection Shield
6	119-P-RR-14	1	Thickness Kit
7	119-P-RR-15	1	Cover
8	119-P-RR-16	2	Thickness Kit
9	119-P-RR-17	1	Cover
10	119-P-RR-18	1	Snap Ring
11	851-M5-.8-10-YZ	4	Cap Screw
12	851-M10-1.5-25-Z	6	Machine Bolt

3200 SERIES PLANETARY
MODELS: 815P / 815C / 1015P / 1015C / 1215

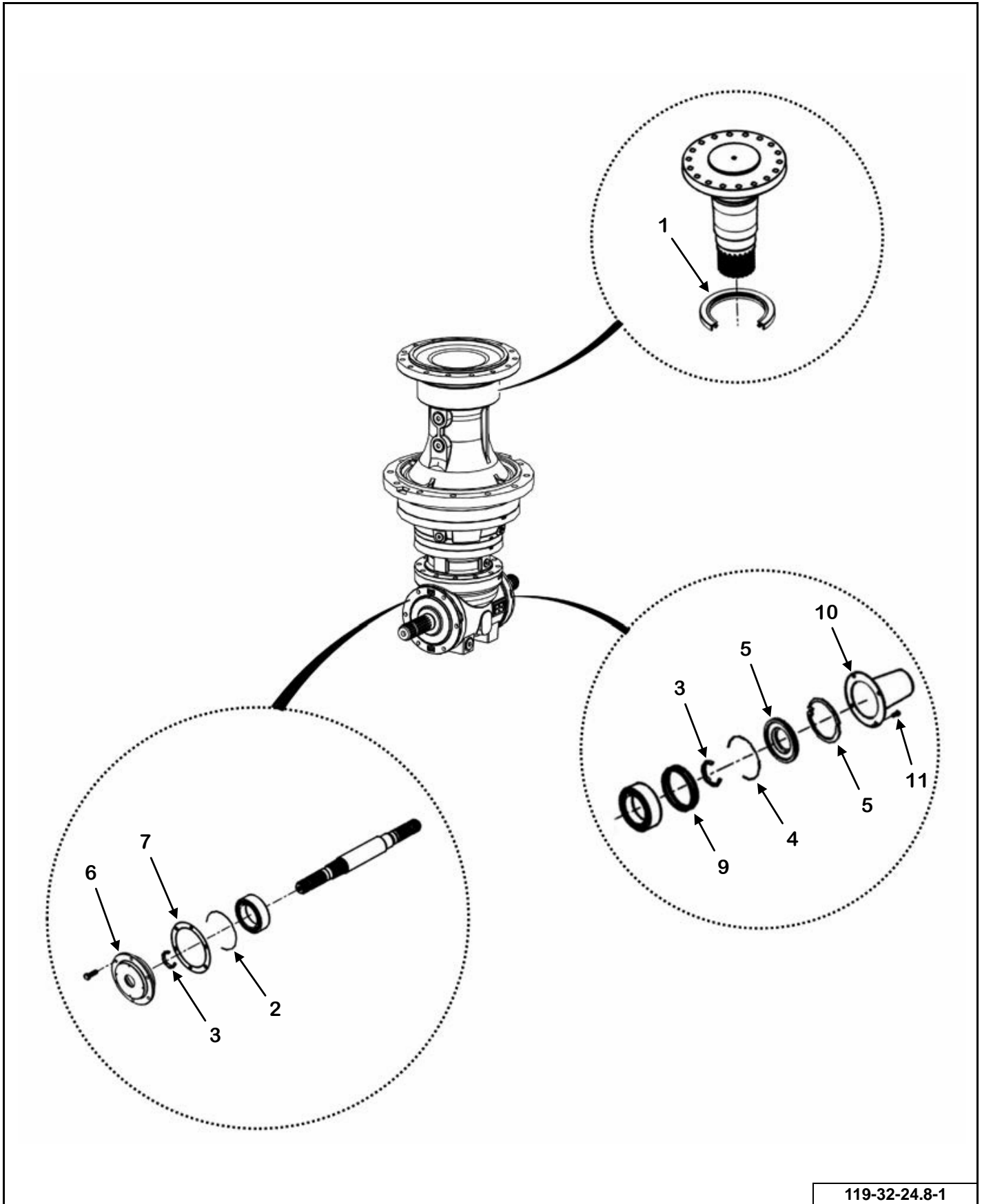

119-32-24.8-1

KEY	PART NUMBER	QTY	DESCRIPTION
0	119-32-24.8-1	2	3200 Series Planetary Gearbox
1	119-P-RR-11	1	Oil Seal
2	119-P-RR-5	1	O-Ring
3	119-P-RR-6	2	Oil Seal
4	119-P-RR-7	1	O-Ring
5	119-P-RR-18	1	Snap Ring
6	119-P-RR-15	1	Cover
7	119-P-RR-14	1	Thickness Kit
8	119-P-RR-17	1	Cover
9	119-P-RR-16	1	Thickness Kit
10	119-P-RR-13	1	Shaft Protection Shield
11	851-M5-.8-10-YZ	4	Cap Screw

STOP & SHIFT PLANETARY GEARBOX OIL SYSTEM

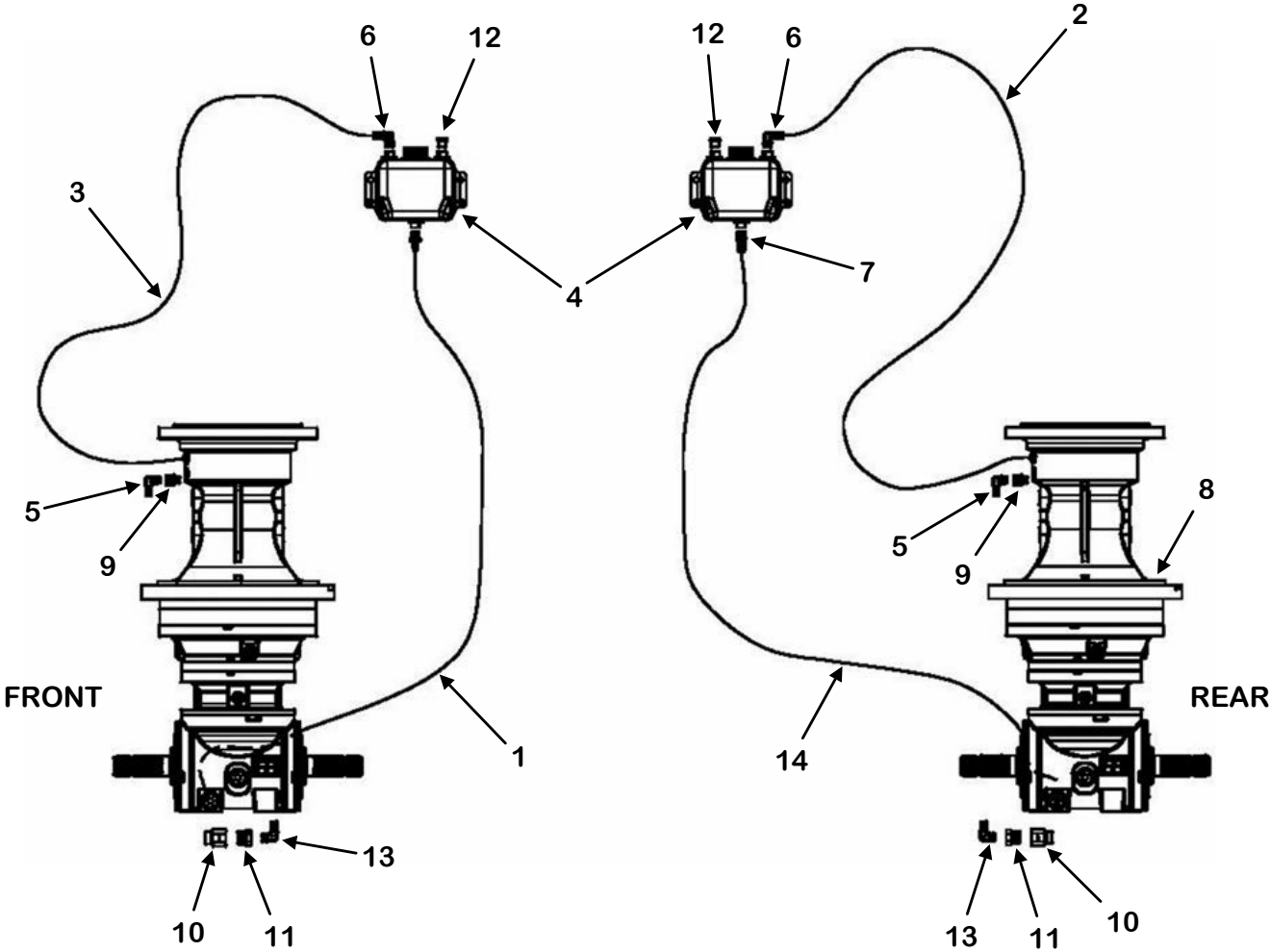

Use #48-0081 Synthetic
ISO220 or Equivalent For
Planetary Gearboxes.

FM-ML-0031-1

KEY	PART NUMBER	QTY	DESCRIPTION	MIXER MODEL
1	155-2231-08	130"	1/2" ID x 3/4" OD Push On Hose	815 - 1215
2	155-2231-08	142"	1/2" ID x 3/4" OD Push On Hose	815/1015
	155-2231-08	147"	1/2" ID x 3/4" OD Push On Hose	815P/815C/ 1015P/1015C/ 1215
3	155-2231-08	153"	1/2" ID x 3/4" OD Push On Hose	815/1015
	155-2231-08	158"	1/2" ID x 3/4" OD Push On Hose	815P/815C/ 1015P/1015C/ 1215
4	952-0004	2	4 QT Plastic Tank With Vented Cap	815 - 1215
5	55-0403	2	1/2" x 1/4" BRS 90° Elbow	815/1015
	55-0404	2	1/2" x 3/8" BRS MA Barb Hose	815P/815C/ 1015P/1015C/ 1215
6	55-0404	2	1/2" x 3/8" BRS MA Barb Hose	815 - 1215
7	55-0405	2	1/2" x 3/8" BRS MA Barb Hose	815 - 1215
8	See Page 186	2	2100 Planetary Gearbox 25.67:1 Ratio 1.75-20 SPL	815/1015
	See Page 188	2	3200 Planetary Gearbox 24.8:1 Ratio 1.75-20 SPL	815P/815C/ 1015P/1015C/ 1215
9	155-PB4-4	2	#4NPT FEMx4BSPP Adapter With BSP Bonded Seal	815/1015
	155-PB06-06	2	#06NPT FEMx06BSPP Adapter With BSP Bonded Seal	815P/815C/ 1015P/1015C/ 1215
10	155-PB08-08	2	#08NPT FEMx08 BSPP Adapter W/BSP Bonded Seal Prior to SN 19VM(0815202, 1015206)	815/1015
	155-PB12-12	2	#12NPT FEMx12BSPP Adapter W/BSP Bonded Seal SN 19VM(0815202, 1015206) & Later	815/1015
	155-PB08-08	2	#08NPT FEMx08BSPP Adapter W/BSP Bonded Seal	815P/815C/ 1015P/1015C/ 1215
11	55-0044	2	12MP-08FP Pipe Reducer Bushing 3/4"-1/2" SN 19VM(0815202, 1015206) & Later	815/1015
12	55-0307	2	Breather Vent 3/8" Pipe x 11/16" Hex 150 PSI	815 - 1215
13	55-0406	2	1/2" x 1/2" BRS 90° Elbow Barb	815 - 1215
14	155-2231-08	130"	1/2" ID x 3/4" OD Push On Hose	815 - 1215

POWER SHIFT PLANETARY GEARBOX OIL SYSTEM

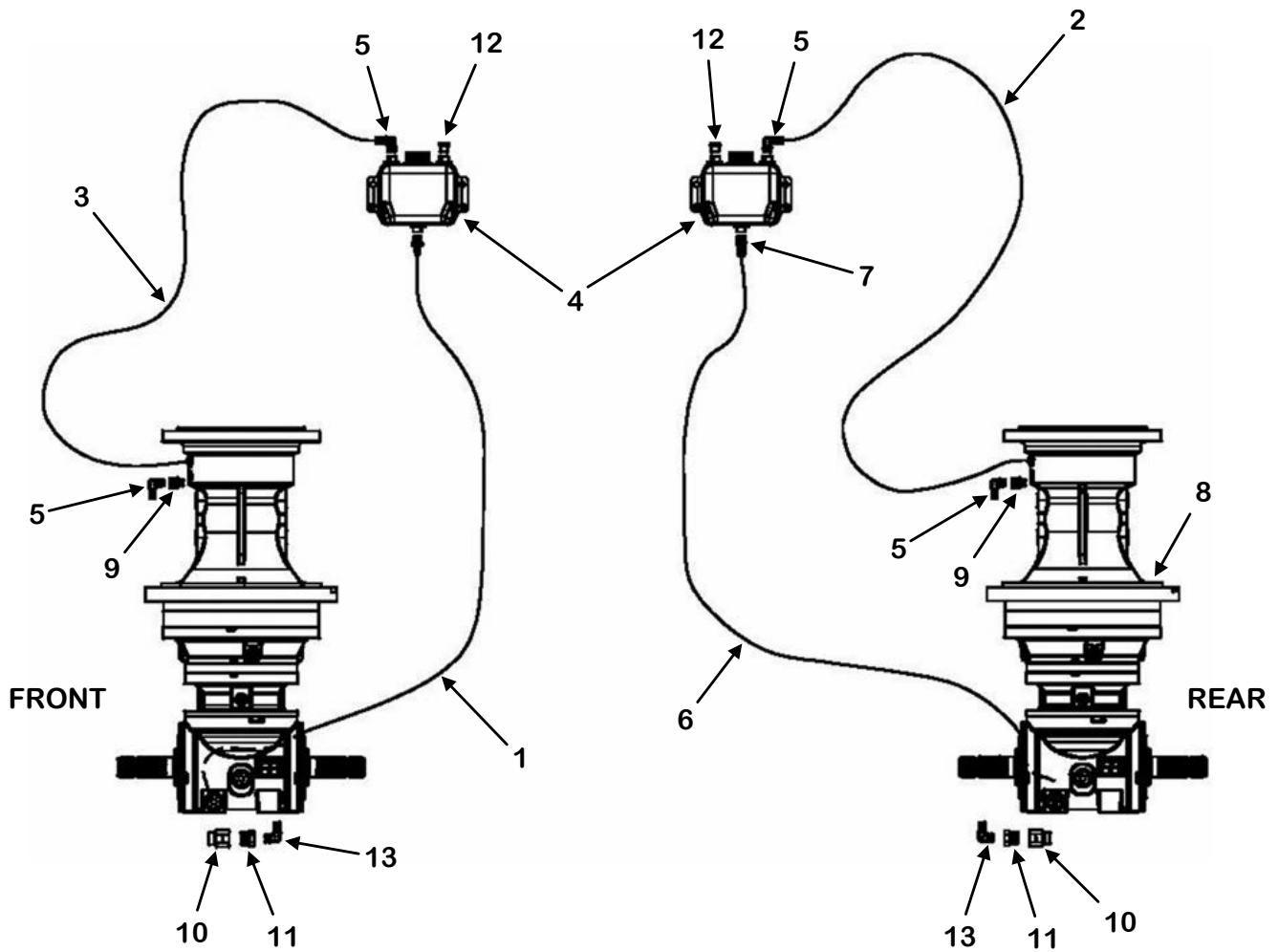

Use #48-0081 Synthetic
ISO220 or Equivalent For
Planetary Gearboxes.

FM-ML-0051-1

KEY	PART NUMBER	QTY	DESCRIPTION	MIXER MODEL
1	155-2231-08	130"	1/2" ID x 3/4" OD Push On Hose	815 - 1215
2	155-2231-08	147"	1/2" ID x 3/4" OD Push On Hose	815 - 1215
3	155-2231-08	158"	1/2" ID x 3/4" OD Push On Hose	815 - 1215
4	952-0004	2	4 QT Plastic Tank With Vented Cap	815 - 1215
5	55-0404	4	1/2" x 3/8" BRS MA Barb Hose	815 - 1215
6	155-2231-08	130"	1/2" ID x 3/4" OD Push On Hose	815 - 1215
7	55-0405	2	1/2" x 3/8" BRS MA Barb Hose	815 - 1215
8	See Page 188	2	3200 Planetary Gearbox 24.8:1 Ratio 1.75-20 SPL	815 - 1215
9	155-PB06-06	2	#06NPT FEMx06BSPP Adapter With BSP Bonded Seal	815 - 1215
10	155-PB12-12	2	#12NPT FEMx12BSPP Adapter W/BSP Bonded Seal	815 - 1215
11	55-0044	2	12MP-08FP Pipe Reducer Bushing 3/4"-1/2"	815 - 1215
12	55-0307	2	Breather Vent 3/8" Pipe x 11/16" Hex 150 PSI	815 - 1215
13	55-0406	2	1/2" x 1/2" BRS 90° Elbow Barb	815 - 1215

STOP & SHIFT GEARBOX OIL SYSTEM
MODELS: 815 / 1015 / (1015P Prior to SN 21VM1015205)

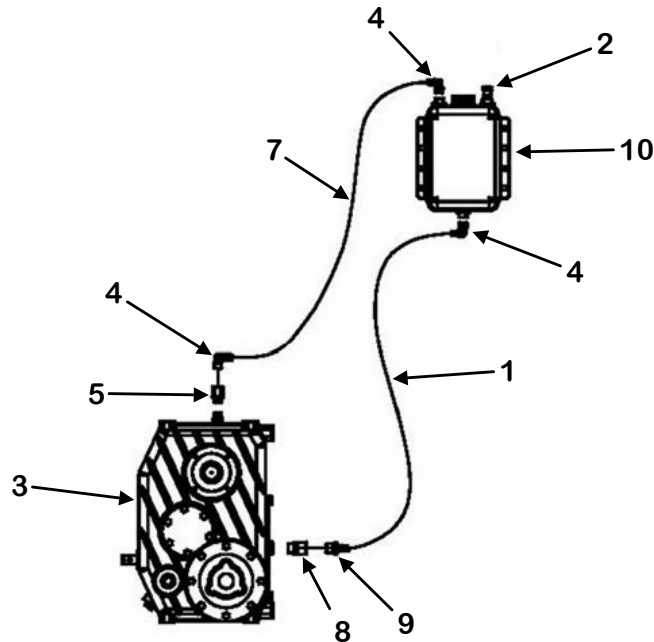

Use #48-0081 Synthetic
 ISO220 or Equivalent Oil For

FM-ML-0032-1

STOP & SHIFT GEARBOX OIL SYSTEM
MODELS: 815P / 815C / (1015P SN 21VM1015205 & Later) / 1015C / 1215

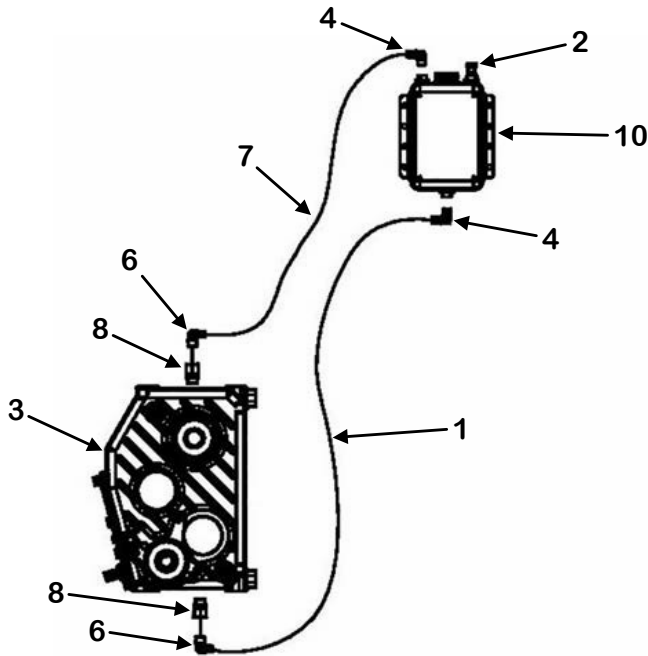

Use #48-0081 Synthetic
 ISO220 or Equivalent Oil For

FM-ML-0033-1

KEY	PART NUMBER	QTY	DESCRIPTION	MIXER MODEL
1	155-2231-08	24.5"	1/2" ID x 3/4" OD Push On Hose	815/1015
	155-2231-08	24.5"	1/2" ID x 3/4" OD Push On Hose (Prior to SN 21VM1015205)	1015P
	155-2231-08	22.5"	1/2" ID x 3/4" OD Push On Hose (1015P SN 21VM1015205 & Later)	815P/815C/ 1015P/1015C/ 1215
2	55-0307	1	Breather Vent 3/8" 150 PSI	815 - 1215
3	See Page 172	1	2-Speed Shifting Gearbox 1.00:1/1.50:1 1.75-20 Spline	815/1015
	See Page 172	1	2-Speed Shifting Gearbox 1.00:1/1.50:1 1.75-20 Spline (Prior to SN 21VM1015205)	1015P
	See Page 176	1	2-Speed Shifting Gearbox 1.00:1/1.50:1 1.75-20 Spline (1015P SN 21VM1015205 & Later)	815P/815C/ 1015P/1015C/ 1215
4	55-0406	3	1/2" x 3/8" BRS 90° Elbow Barb	815/1015
	55-0406	3	1/2" x 3/8" BRS 90° Elbow Barb (Prior to SN 21VM1015205)	1015P
	55-0406	2	1/2" x 3/8" BRS 90° Elbow Barb (1015P SN 21VM1015205 & Later)	815P/815C/ 1015P/1015C/ 1215
5	155-PB06-06	1	#06 Female NPT x 06 BSPP Adapter W/BSP Bonded Seal	815/1015
	155-PB06-06	1	#06 Female NPT x 06 BSPP Adapter W/BSP Bonded Seal (Prior to SN 21VM1015205)	1015P
6	55-0406	2	1/2" x 1/2" BRS 90° Elbow Barb (1015P SN 21VM1015205 & Later)	815P/815C/ 1015P/1015C/ 1215
7	155-2231-08	32"	1/2" ID x 3/4" OD Push On Hose	815/1015
	155-2231-08	32"	1/2" ID x 3/4" OD Push On Hose (Prior to SN 21VM1015205)	1015P
	155-2231-08	34.75"	1/2" ID x 3/4" OD Push On Hose (1015P SN 21VM1015205 & Later)	815P/815C/ 1015P/1015C/ 1215
8	155-PB08-08	1	#08 Female NPT x 08 BSPP Adapter W/BSP Bonded Seal	815/1015
	155-PB08-08	1	#08 Female NPT x 08 BSPP Adapter W/BSP Bonded Seal (Prior to SN 21VM1015205)	1015P
	155-PB08-08	2	#08 Female NPT x 08 BSPP Adapter W/BSP Bonded Seal (1015P SN 21VM1015205 & Later)	815P/815C/ 1015P/1015C/ 1215
9	55-0410	1	1/2" Hose ID x 1/2" NPT Male Hose Barb	815/1015
	55-0410	1	1/2" Hose ID x 1/2" NPT Male Hose Barb (Prior to SN 21VM1015205)	1015P
10	952-0004	1	4 QT Plastic Tank With Vented Cap	815 - 1215
NS	32-0048	AR	Hose Clamps	815 - 1215

POWER SHIFT TRANSMISSION OIL COOLING SYSTEM

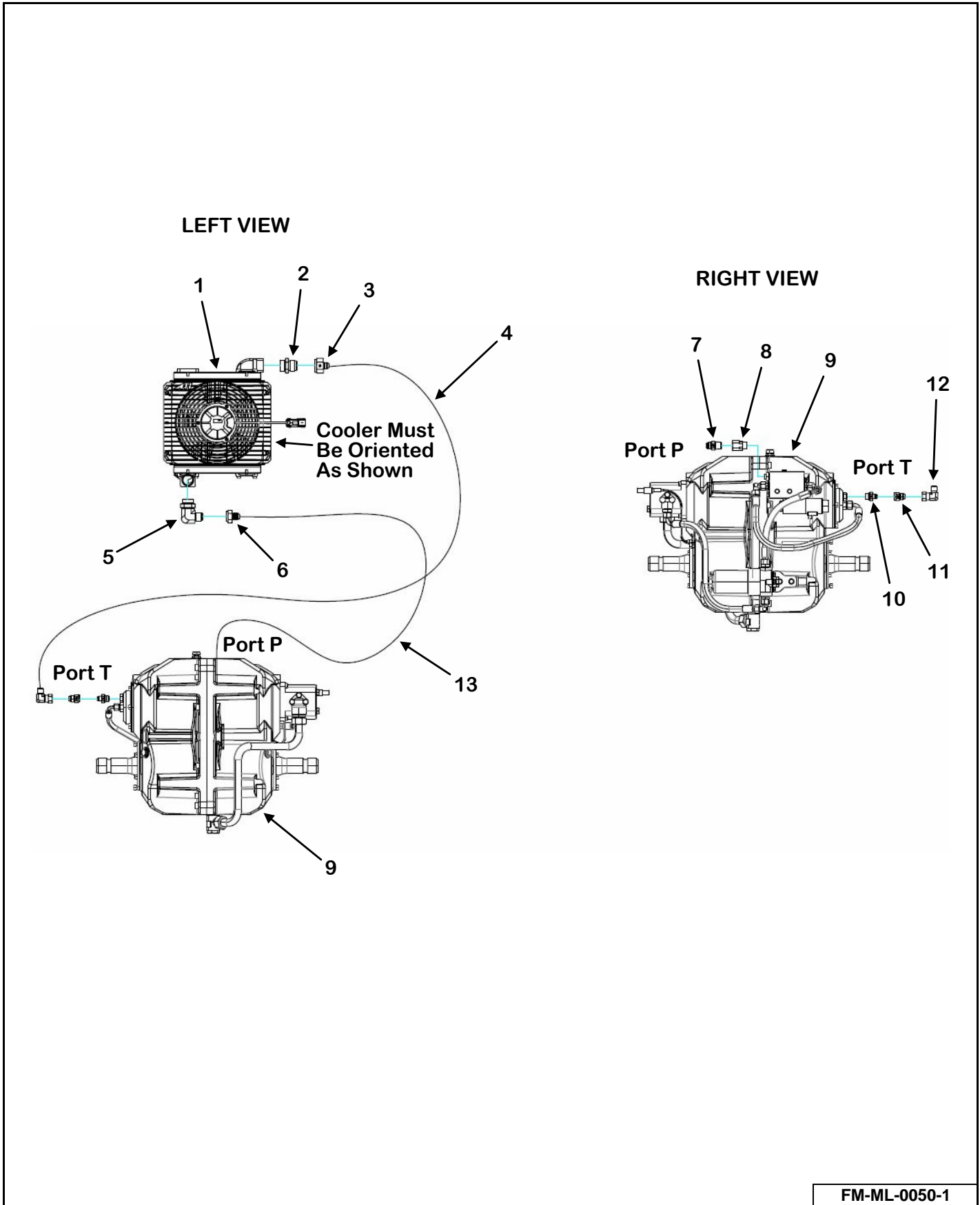

FM-ML-0050-1

KEY	PART NUMBER	QTY	DESCRIPTION	MIXER MODEL
1	155-OC-TT07-1	1	12V Hydraulic Cooler	815 - 1215
2	155-6400-16-16	1	Straight Adapter	815 - 1215
3	155-2406-16-8	1	Straight Adapter	815 - 1215
4	155-08R17-69-1	1	1/2" x 69" Hose	815 - 1215
5	155-6801-12-16	1	90° Adapter	815 - 1215
6	155-2406-12-08	1	Straight Adapter	815 - 1215
7	155-2404-08-08	1	Straight Adapter	815 - 1215
8	155-P08-08	1	Straight Adapter	815 - 1215
9	See Pages 182 & 184	1	Zuidberg 2-Speed Automatic Transmission	815 - 1215
10	155-7005-06-16	1	Straight Adapter	815 - 1215
11	155-2406-06-08	1	Straight Adapter	815 - 1215
12	155-6500-08-08	1	90° Adapter	815 - 1215
13	155-08R17-52-1	1	1/2" x 52" Hose	815 - 1215

LARGE MIXER 1-3/8-21 SPLINE X 1-3/4-20 SPLINE PTO DRIVE SHAFT

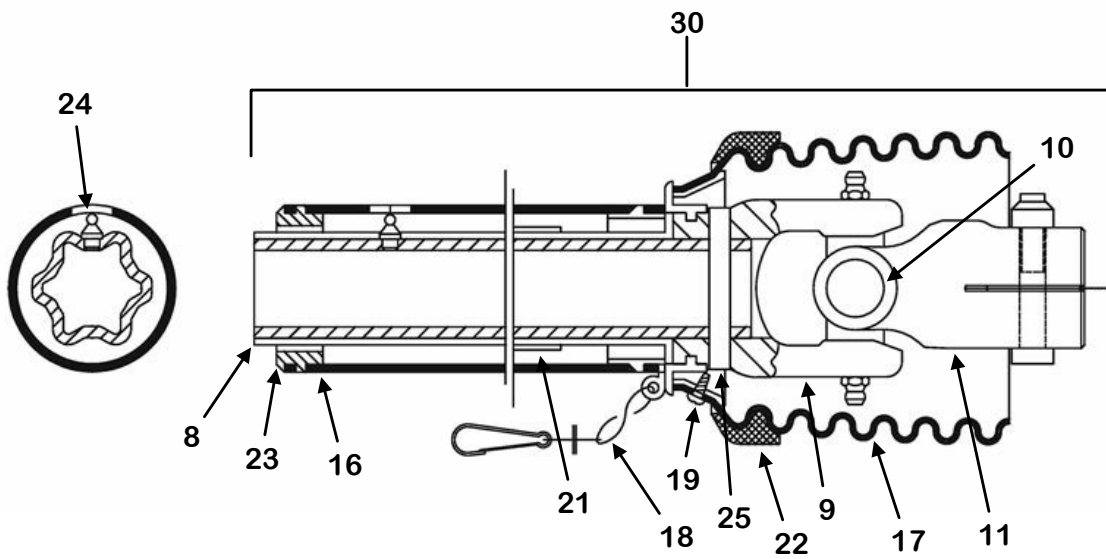
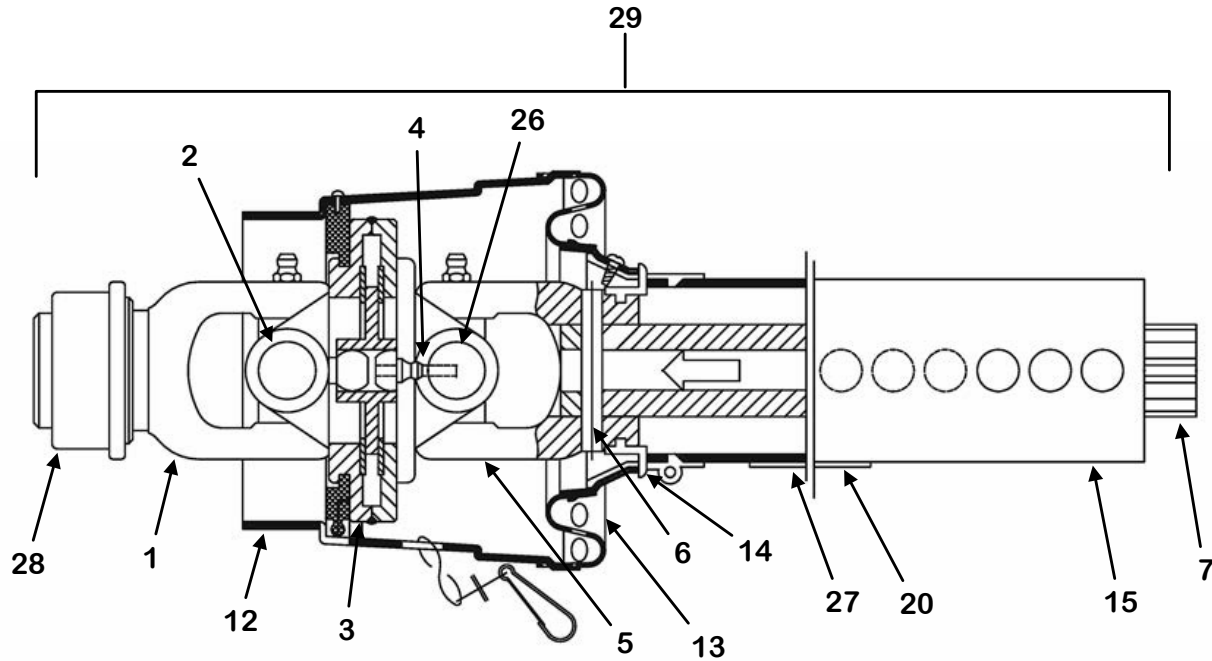

118-VM-0023-55

KEY	PART NUMBER	QTY	DESCRIPTION
0	118-VM-0023-55	1	1-3/8"-21 Spline PTO Complete
1	918-0511-1-1	1	Yoke ASG (Includes Item 28)
2	918-0511-1-2	1	Cross & Bearing Kit
3	918-0511-1-3	1	Double Yoke (Includes Item 4)
4	918-0208-1-2	1	Zerk
5	918-0511-1-5	1	Inboard Yoke
6	918-0308-1-5	1	Spring Pin, 10 x 75
7	118-VM-0024-55-3	1	Inner Profile
8	118-VM-0024-55-4	1	Outer Profile (Includes Items 21 & 24)
9	618-0201-2-2	1	Inboard Yoke
10	118-VM-0010-25-2	1	Cross & Bearing Kit
11	118-VM-0010-25-1	1	Yoke 1-3/4"-20 SPL
12	618-0202-1-11	1	CV Guard & Bearing Assembly (Includes Items 14 & 19)
13	918-0212-1-5	1	Flex Net & Guard Assembly (Includes Item 19)
14	918-0208-2-4	2	Bearing Ring
15	118-VM-0024-55-5	1	Guard Tube Outer (Includes Item 20)
16	118-VM-0024-55-6	1	Guard Tube Inner
17	118-VM-0024-55-7	1	Guard Cone, 7 Rib (Includes Item 19)
18	918-0208-2-7	2	Restraint Chain
19	918-0208-2-9	10	Screw
20	918-0208-2-8	1	Decal Outer
21	918-0208-1-10	1	Decal Inner
22	618-0202-2-8	1	Reinforcing Collar
23	618-0202-1-10	1	Support Bearing
24	918-0208-1-12	1	Zerk
25	618-0202-2-5	1	Spring Pin, 10 x 90
26	918-0511-1-4	1	Cross & Bearing Kit
27	918-0308-2-6	1	Decal, Lubrication
28	918-0511-1-1-1	1	ASG Collar Kit
29	118-VM-0023-55-1	1	Tractor Half Shaft
30	118-VM-0024-55-2	1	Implement Half Shaft

LARGE MIXER 1-3/8-21 SPLINE X 1-3/4-20 SPLINE PTO DRIVE SHAFT (OPTIONAL)

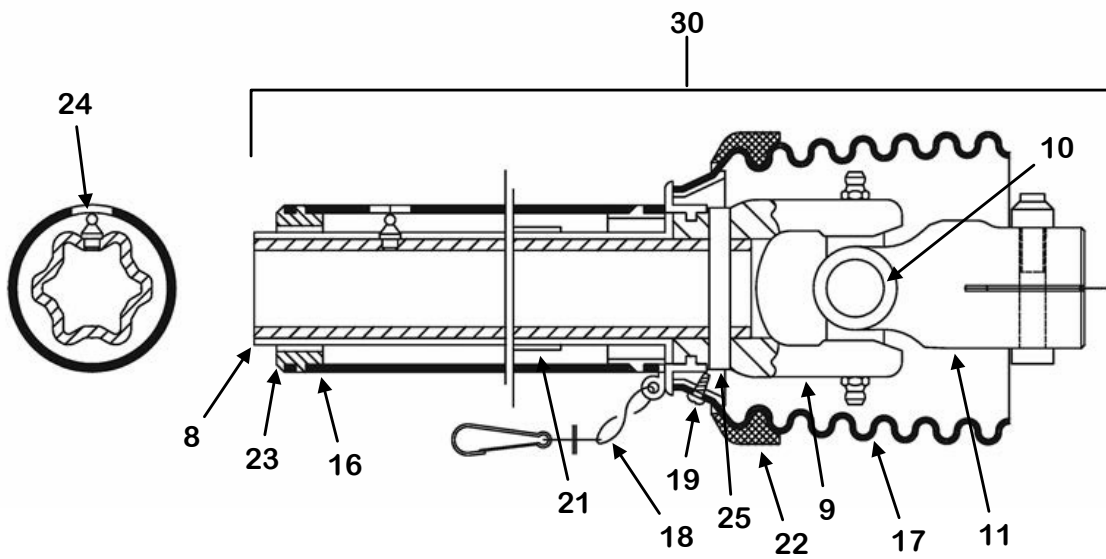
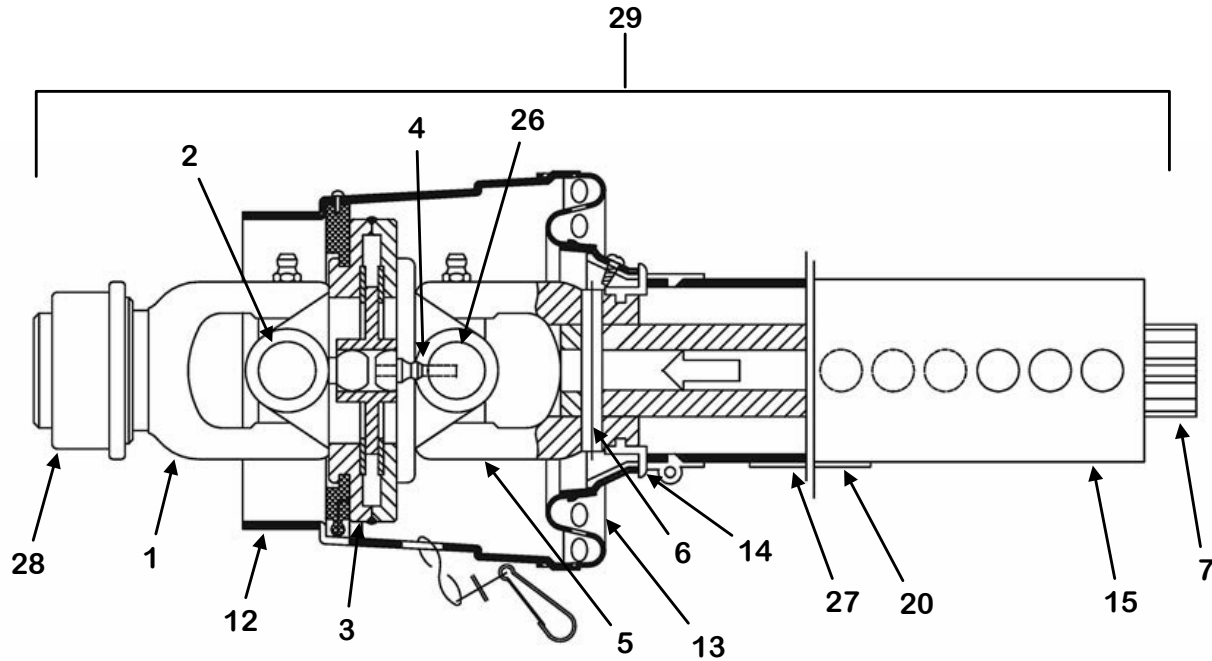

118-VM-0024-55

KEY	PART NUMBER	QTY	DESCRIPTION
0	118-VM-0024-55	1	1-3/4"-20 Spline PTO Complete
1	918-0512-1-1	1	Yoke ASG (Includes Item 28)
2	918-0511-1-2	1	Cross & Bearing Kit
3	918-0511-1-3	1	Double Yoke (Includes Item 4)
4	918-0208-1-2	1	Zerk
5	918-0511-1-5	1	Inboard Yoke
6	918-0308-1-5	1	Spring Pin, 10 x 75
7	118-VM-0024-55-3	1	Inner Profile
8	118-VM-0024-55-4	1	Outer Profile (Includes Items 21 & 24)
9	618-0201-2-2	1	Inboard Yoke
10	118-VM-0010-25-2	1	Cross & Bearing Kit
11	118-VM-0010-25-1	1	Yoke 1-3/4"-20 SPL
12	618-0202-1-11	1	CV Guard & Bearing Assembly (Includes Item 19)
13	918-0212-1-5	1	Flex Net & Guard Assembly (Includes Item 19)
14	918-0208-2-4	2	Bearing Ring SC25
15	118-VM-0024-55-5	1	Guard Tube Outer (Includes Item 20)
16	118-VM-0024-55-6	1	Guard Tube Inner
17	118-VM-0024-55-7	1	Guard Cone, 7 Rib (Includes Item 19)
18	918-0208-2-7	2	Restraint Chain
19	918-0208-2-9	10	Screw
20	918-0208-2-8	1	Decal Outer
21	918-0208-1-10	1	Decal Inner
22	618-0202-2-8	1	Reinforcing Collar
23	618-0202-1-10	1	Support Bearing
24	618-0208-1-12	1	Zerk
25	618-0202-2-5	1	Spring Pin, 10 x 90
26	918-0511-1-4	1	Cross & Bearing Kit
27	918-0308-2-6	1	Decal, Lubrication
28	918-0210-1-1-1	1	ASG Collar Kit
29	118-VM-0024-55-1	1	Tractor Half Shaft
30	118-VM-0024-55-2	1	Implement Half Shaft

POWER SHIFT 1-3/4-20 SPLINE X 1-3/4-20 SPLINE PTO DRIVE SHAFT

Prior to SN 25VM(0815201, 1015203, 1215201)

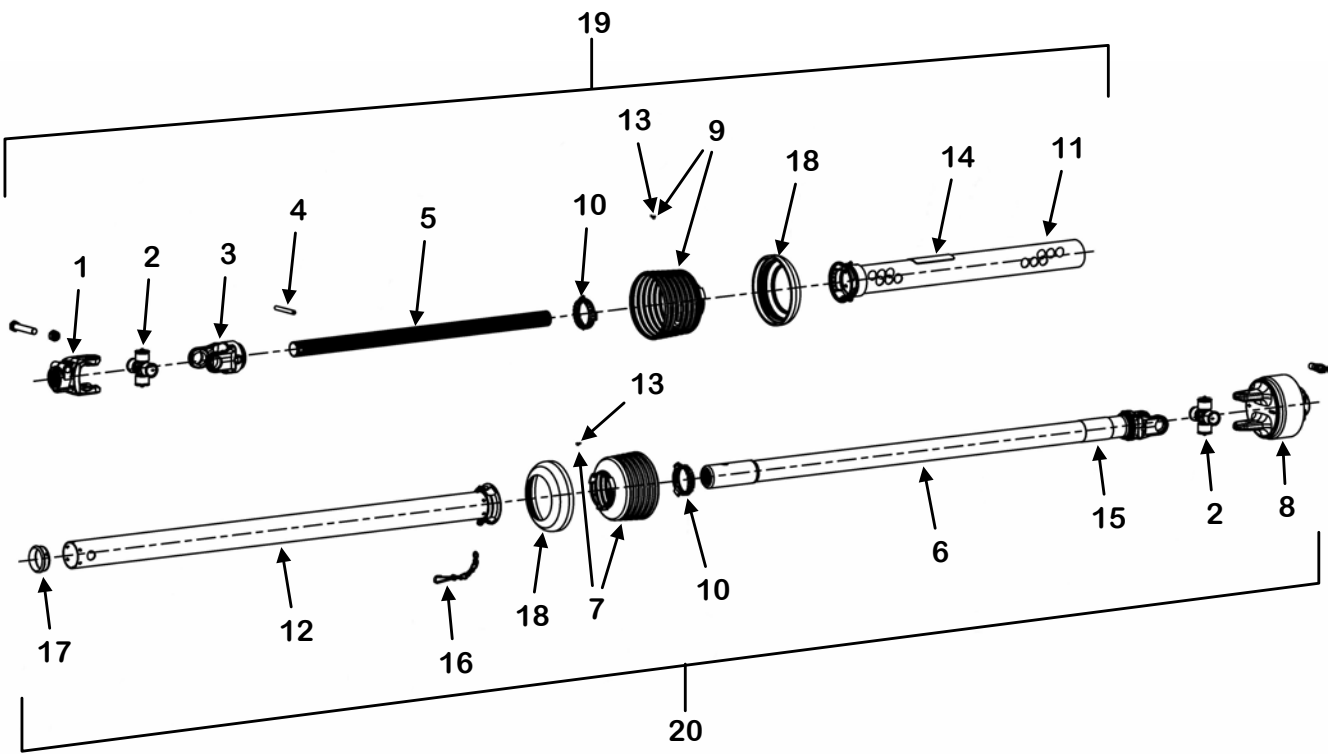

118-VM-0003-2500

KEY	PART NUMBER	QTY	DESCRIPTION
0	118-VM-0031-55	1	1-3/4"-20 Spline PTO Complete
1	118-VM-0010-25-1	1	Yoke
2	118-VM-0010-25-2	2	Cross & Bearing Kit
3	118-VM-0020-55-3	1	Inboard Yoke
4	618-0202-2-5	1	Spring Pin
5	118-2500-5	1	Inner Profile
6	118-VM-0020-55-5	1	Inboard Yoke Tube
7	118-2500-7	1	Guard Cone, 6 Rib
8	See Page 208	1	Cutout Clutch
9	118-VM-0024-55-7	1	Guard Cone, 7 Rib
10	918-0208-2-4	2	Bearing Ring SC25
11	118-2500-6	1	Guard Tube Outer
12	118-VM-0020-55-8	1	Guard Tube Inner
13	918-0208-2-9	2	Screw
14	918-0208-2-8	1	Decal Outer
15	918-0208-1-10	1	Decal Inner
16	918-0208-2-7	1	Restraint Chain
17	918-0208-1-11	1	Support Bearing
18	618-0202-2-8	2	Reinforcing Collar
19	118-VM-0003-2500-1	1	Power Shift Transmission Half
20	118-VM-0003-2500-2	1	Planetary Half

POWER SHIFT 1-3/4-20 SPLINE X 1-3/4-20 SPLINE PTO DRIVE SHAFT
SN 25VM(0815201, 1015203, 1215201) & Later

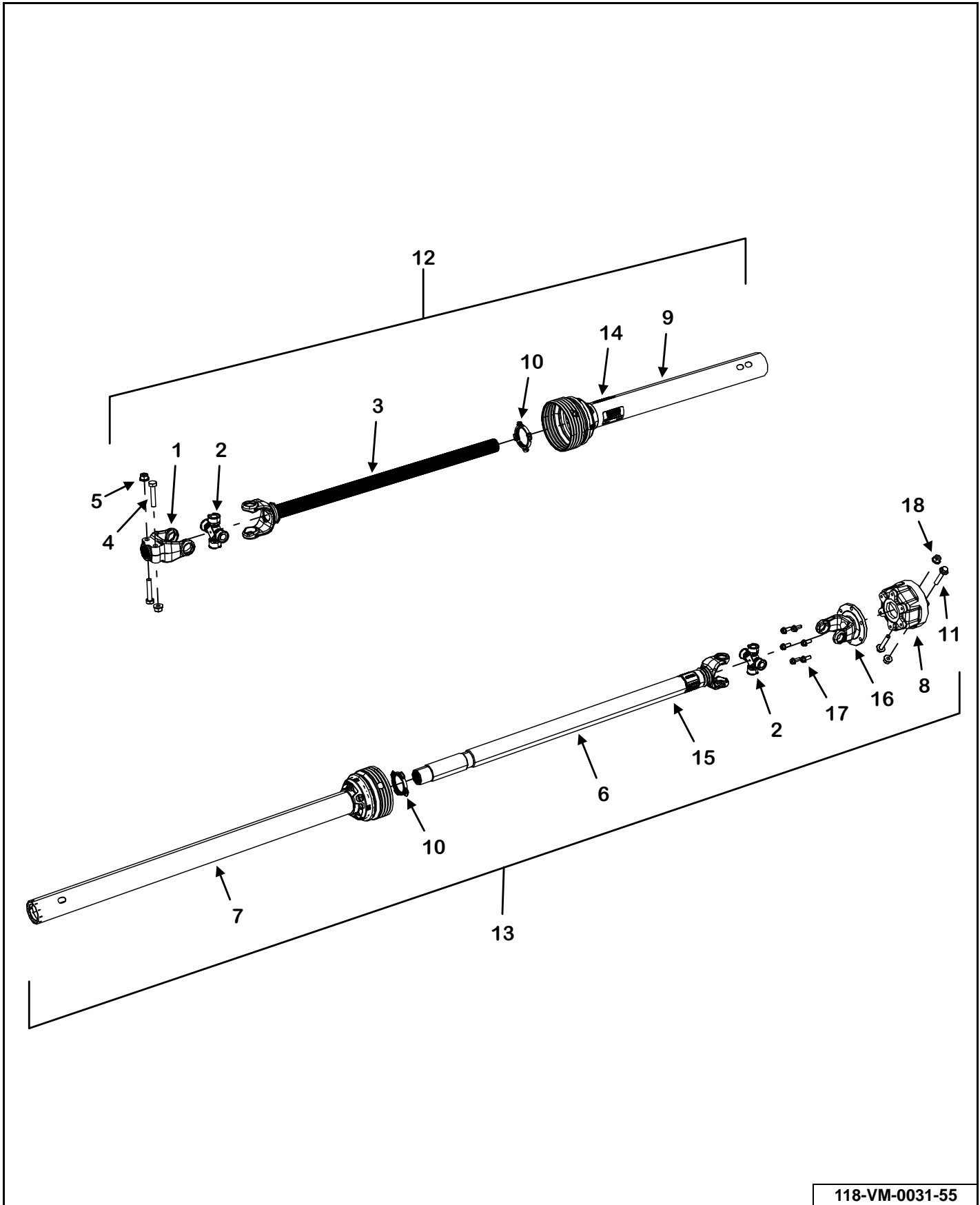

118-VM-0031-55

KEY	PART NUMBER	QTY	DESCRIPTION
0	118-VM-0031-55	1	1-3/4"-20 Spline PTO Complete
1	118-VM-0031-55-1-4	1	Yoke
2	118-VM-01-55-1-1	2	Cross & Bearing Kit
3	118-VM-0031-55-1-5	1	Inboard Yoke & Shaft
4	118-VM-0031-55-1-2	2	5/8"-11 x 3" Bolt
5	118-VM-0031-55-1-3	2	5/8"-11 Lock Nut
6	118-VM-0031-55-2-3	1	Inboard Yoke Tube
7	118-VM-0031-55-2-2	1	Inner Guard
8	See Page 209	1	Cutout Clutch
9	118-VM-0031-55-1-6	1	Outer Guard
10	118-VM-0001-55-1-4	2	Bearing Ring SC25
11	118-VM-0031-55-2-7	2	M16 x 2 x 80 Hex Flange Bolt
12	118-VM-0031-55-1	1	Power Shift Transmission Half
13	118-VM-0031-55-2	1	Planetary Half
14	918-0001-22	1	Decal Outer
15	918-0001-23	1	Decal Inner
16	118-VM-0031-55-2-4	1	Yoke
17	118-VM-0031-55-2-5	6	M12 x 1.75 Hex Flange Bolt
18	118-VM-0031-55-2-8	2	M16x 2 Lock Nut

1-3/4-20 SPLINE X 1-3/4-20 SPLINE 2500 SERIES DRIVELINE

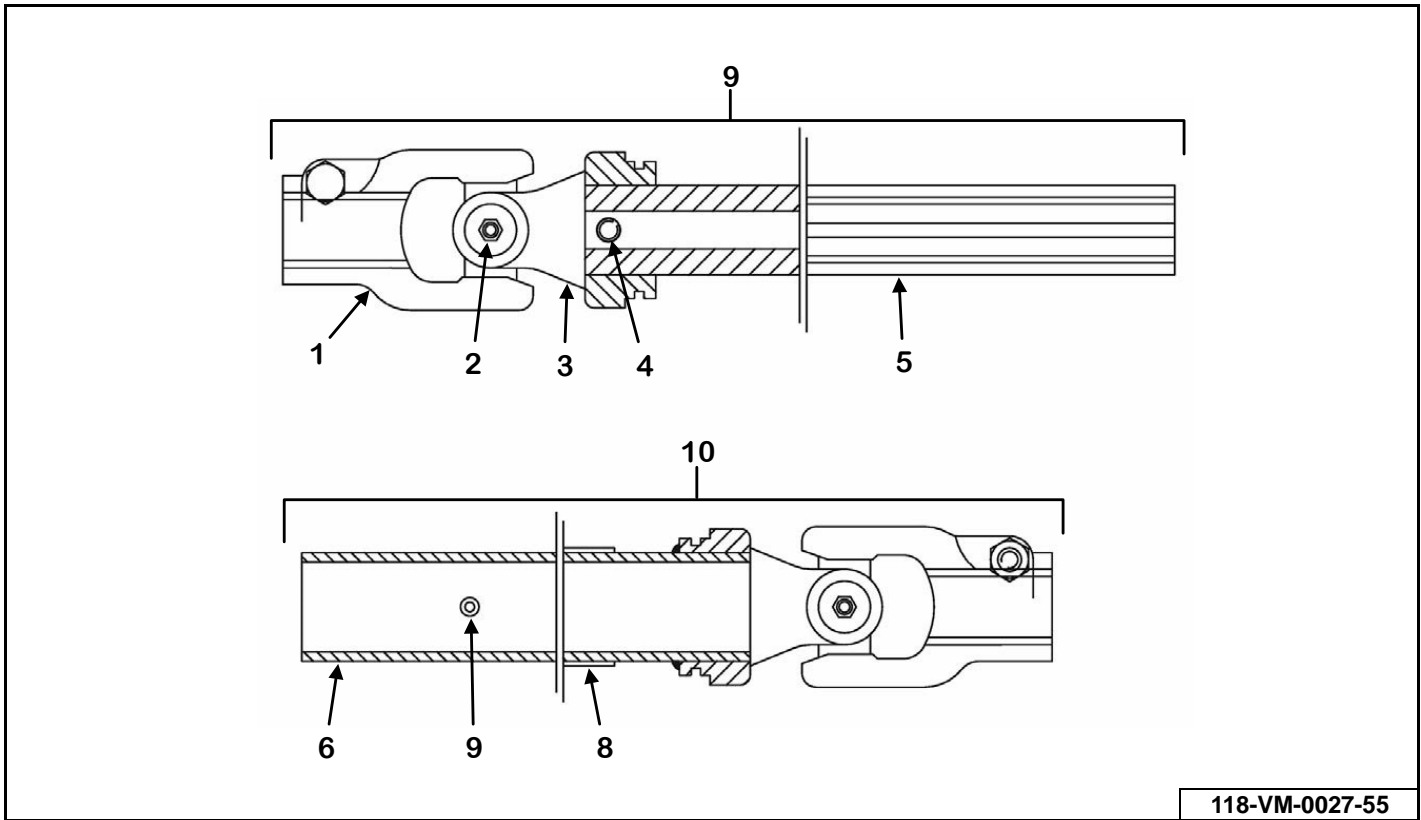

KEY	PART NUMBER	QTY	DESCRIPTION
0	118-VM-0027-55	1	1-3/4-20 Spline PTO Complete
1	118-VM-0010-25-1	2	Yoke AGKF
2	118-VM-0010-25-2	2	Cross & Bearing Kit
3	618-0202-2-2	1	Inboard Yoke
4	618-0202-2-5	1	Spring pin, 10 x 90
5	118-VM-0027-55-3	1	Inner Profile
6	118-VM-0027-55-4	1	Inboard Yoke (Includes Items 8 & 9)
7	618-0007-6	1	Decal
8	918-0208-1-12	2	Zerk
9	118-VM-0027-55-1	1	Male Half Shaft
10	118-VM-0027-55-2	1	Female Half Shaft

DOUBLE UNIVERSAL JOINT W/CUTOUT CLUTCH

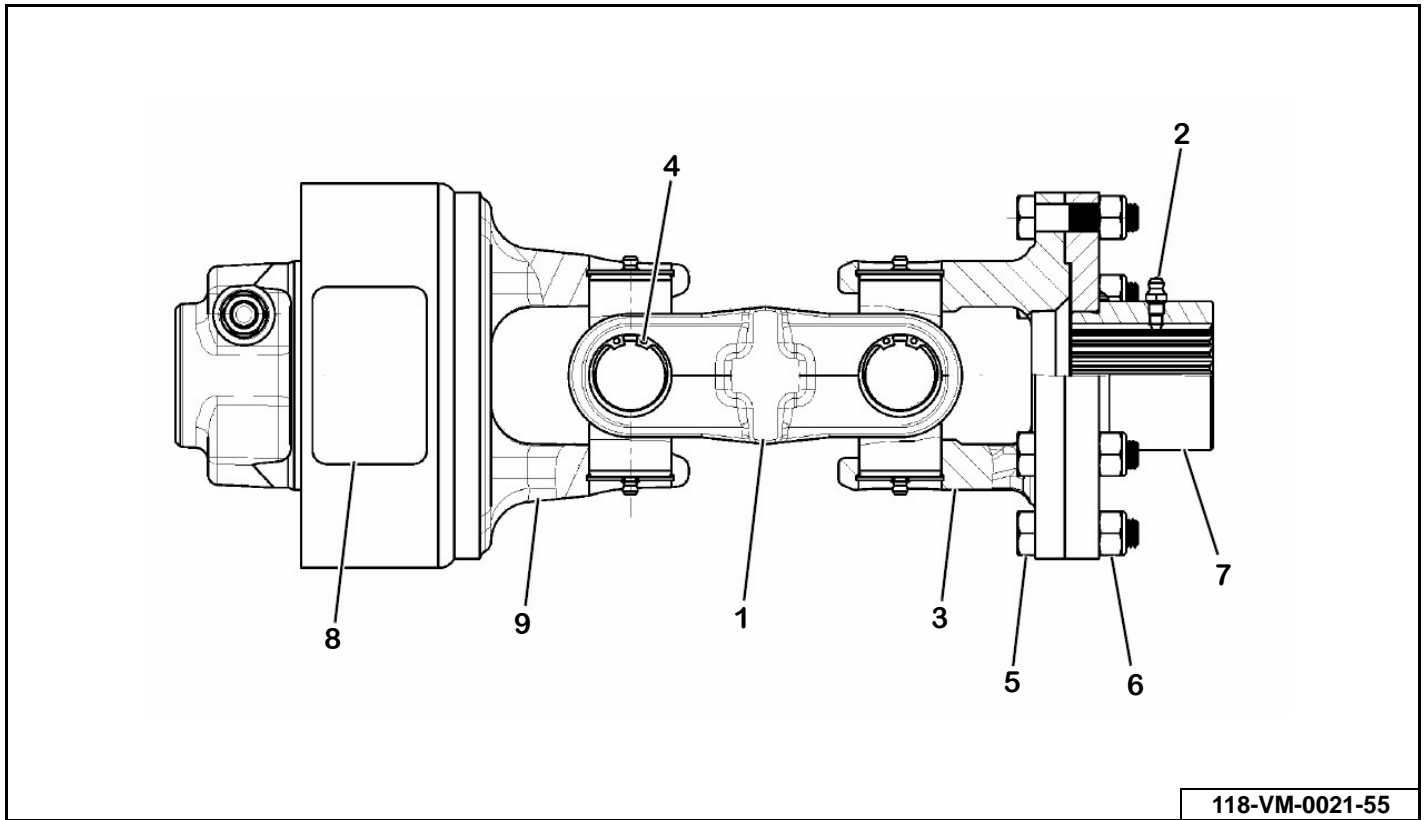

KEY	PART NUMBER	QTY	DESCRIPTION
0	118-VM-0021-55	1	Double Universal Joint W/Cutout Clutch
1	118-VM-0011-25-1	1	Double Yoke
2	618-0005-1-1	1	Zerk
3	118-VM-0011-25-2	1	Flange Yoke
4	118-VM-0010-25-2	2	Cross Kit (Includes Item CC Lock Kit)
	918-0410-2-1-1	2	CC Lock Kit
5	118-VM-0011-25-3	6	Bolt, M12 x 50
6	118-VM-0011-25-4	6	Nut, Lock
7	118-VM-0011-25-5	1	Hub Flange (Includes Item 2)
8	918-0208-2-10	1	Decal K64
9	See Page 208	1	Cutout Clutch Complete

YOKE CUTOUT CLUTCH

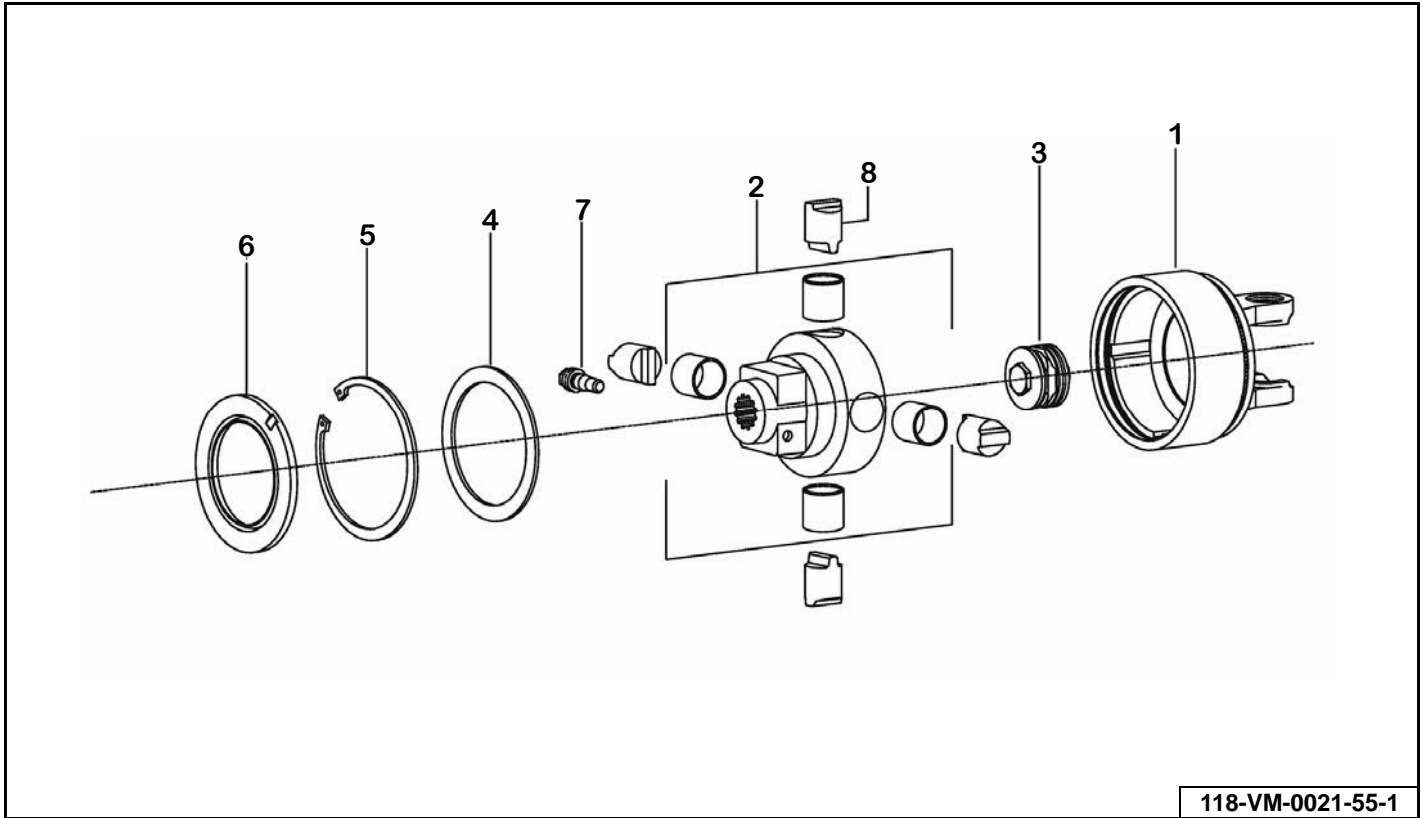

KEY	PART NUMBER	QTY	DESCRIPTION
0	118-VM-0021-55-1	1	Cutout Clutch Complete
1	618-0202-2-3-1	1	Housing
2	118-VM-0021-55-1-1	1	Hub
3	118-VM-0021-55-1-2	1	Spring Pack
4	918-0208-2-3-5	1	Washer
5	918-0208-2-3-6	1	Retaining Ring
6	918-0208-2-3-7	1	Sealing Ring
7	918-0410-2-1-1	1	Clamp Cone Assembly
8	918-0308-2-2-4	4	Cam

CUTOUT CLUTCH

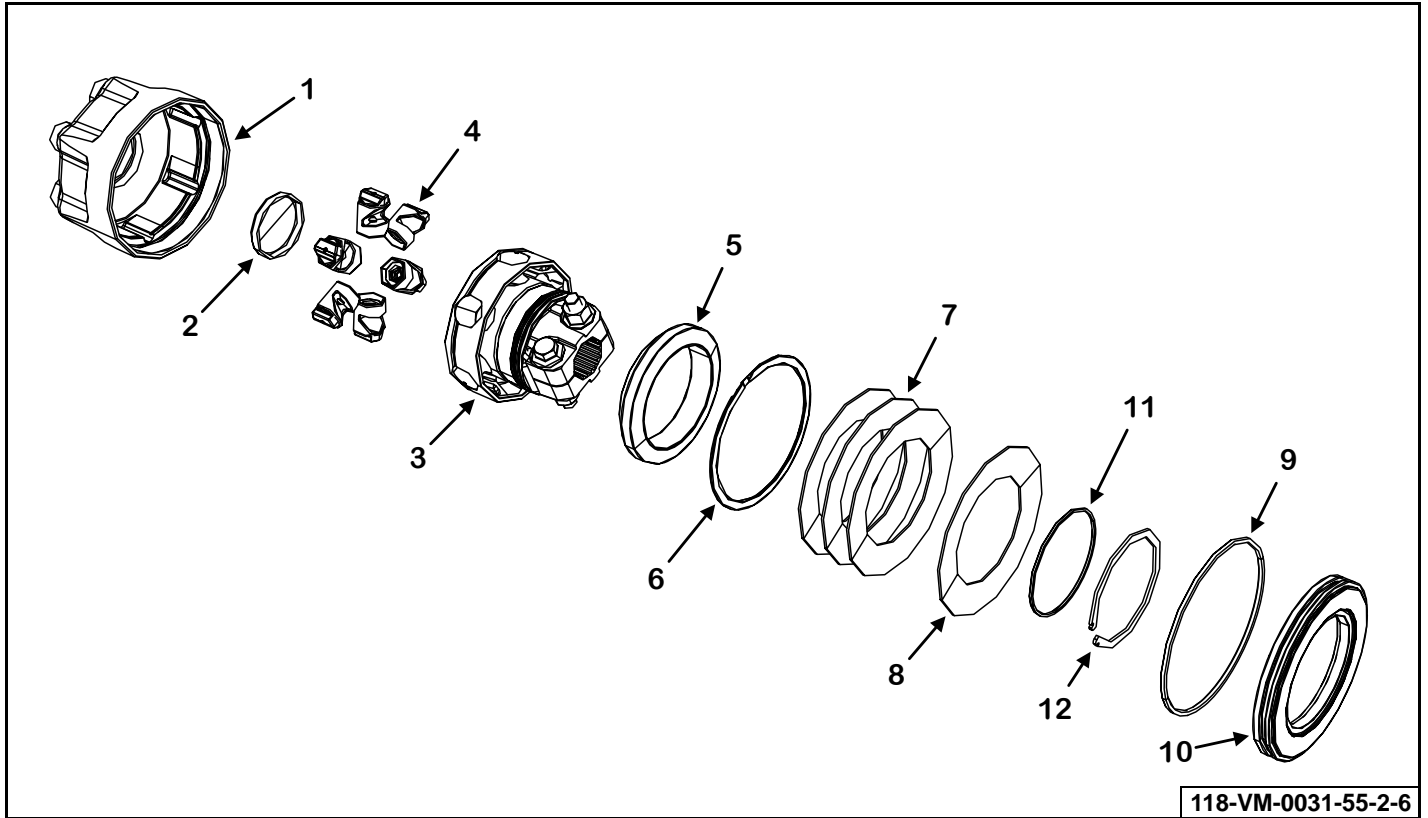

KEY	PART NUMBER	QTY	DESCRIPTION
0	118-VM-0031-55-2-6	1	Cutout Clutch Complete
1	118-VM-0031-55-2-9	1	Housing
2	118-VM-31-55-2-10	1	Plug
3	118-VM-31-55-2-11	1	Hub
4	118-VM-0003-55-1-3	6	Wedge
5	118-VM-0003-55-1-4	1	Wedge Ring
6	118-VM-0003-55-1-5	1	Retaining Ring
7	118-VM-31-55-2-12	3	Disc Spring
8	118-VM-0003-55-1-6	1	Disc Spring
9	118-VM-0003-55-1-8	1	O-Ring
10	118-VM-31-55-2-13	1	Compression Plate
11	118-VM-0003-55-1-9	1	O-Ring
12	118-VM-0003-55-1-0	1	Retaining Ring

1-3/4-20 SPLINE X 1-3/4-20 SPLINE DRIVESHAFT

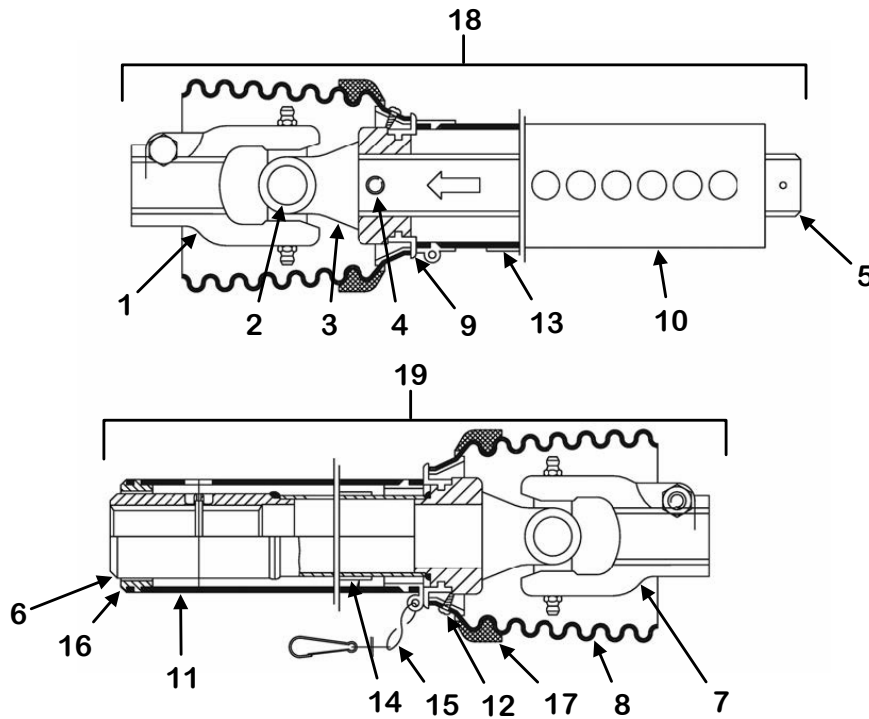

118-VM-0020-55

KEY	PART NUMBER	QTY	DESCRIPTION
0	118-VM-0020-55	1	1-3/4"-20 Spline PTO Complete
1	118-VM-0010-25-1	1	Yoke ASG
2	118-VM-0010-25-2	2	Cross & Bearing Kit
3	118-VM-0020-55-3	1	Inboard Yoke
4	618-0202-2-5	2	Spring Pin, 10 x 90
5	118-VM-0020-55-4	1	Inner Profile
6	118-VM-0020-55-5	1	Inboard Yoke (Includes Item 14)
7	118-VM-0010-25-1	1	Yoke AGKF
8	118-VM-0024-55-7	2	Guard Cone, 7 Rib (Includes Item 12)
9	918-0208-2-4	2	Bearing Ring
10	118-VM-0020-55-7	1	Guard Tube Outer (Includes Item 13)
11	118-VM-0020-55-8	1	Guard Tube Inner
12	918-0208-2-9	2	Screw
13	918-0208-2-8	1	Decal Outer
14	918-0208-1-10	1	Decal Inner
15	918-0208-2-7	1	Restraint Chain
16	918-0208-1-11	1	Support Bearing
17	618-0202-2-8	2	Reinforcing Collar
18	118-VM-0020-55-1	1	Male Half Shaft
19	118-VM-0020-55-2	1	Female Half Shaft

10.0 OPTIONAL PARTS

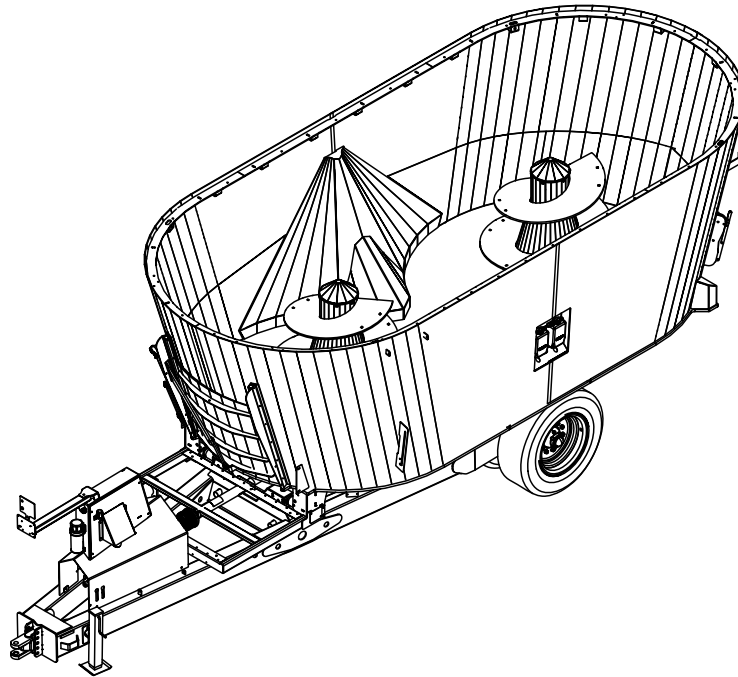

FM-ML-0034-1

KEY	DESCRIPTION	PAGE #
1	HAY RETAINING RING	212
2	8" CAPACITY EXTENSION	213
3	TIP OFF FRONT INCLINE DISCHARGE (CHAIN ONLY) & SIDE DISCHARGE	214
4	SIDE DISCHARGE SLIDE TRAY	215
5	SLIDE TRAY HYDRAULIC SCHEMATIC	216
6	DRUM BRAKE ASSEMBLY	217
7	HAND/FOOT BRAKE CONTROL ACTUATOR ASSEMBLY	218
8	SINGLE AXLE HYDRAULIC BRAKE SCHEMATIC	220
9	TANDEM HYDRAULIC BRAKE SCHEMATIC	221
10	REMOTE SCALE MOUNT	222
11	RUBBER SIDE DOOR CHUTE ASSEMBLY	224
12	CONVEYOR HANGING MAGNET & WEIGHT ASSEMBLY	226
13	CONVEYOR DEFLECTOR ASSEMBLY	226
14	POWER MAGNET	228

HAY RETAINING RING

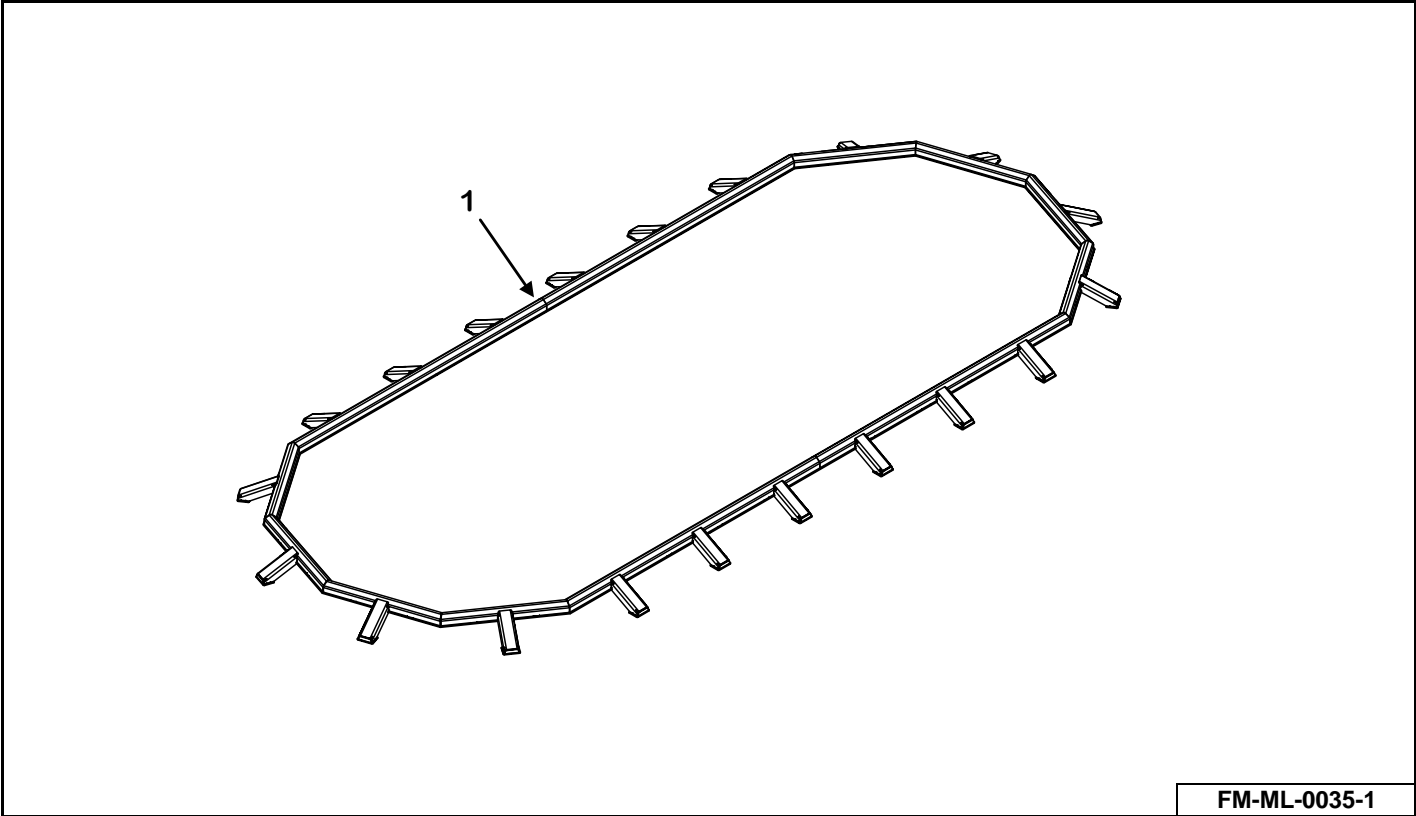

KEY	PART NUMBER	QTY	DESCRIPTION	MIXER MODEL
1	M4-1-8-0007	1	Hay Retention Ring End Weldment	815
	M4-1-10-0002	1	Hay Retention Ring End Weldment	1015
	M4-1-12-0002	1	Hay Retention Ring End Weldment	1215
NS	851-5013-1.5Z	AR	1/2"-13 x 1 1/4" Bolt	815 - 1215
NS	805-0050-Z	AR	1/2" Flat Washer	815 - 1215
NS	810-5013-Z	AR	1/2" Spin Lock Nut	815 - 1215

8" CAPACITY EXTENSION

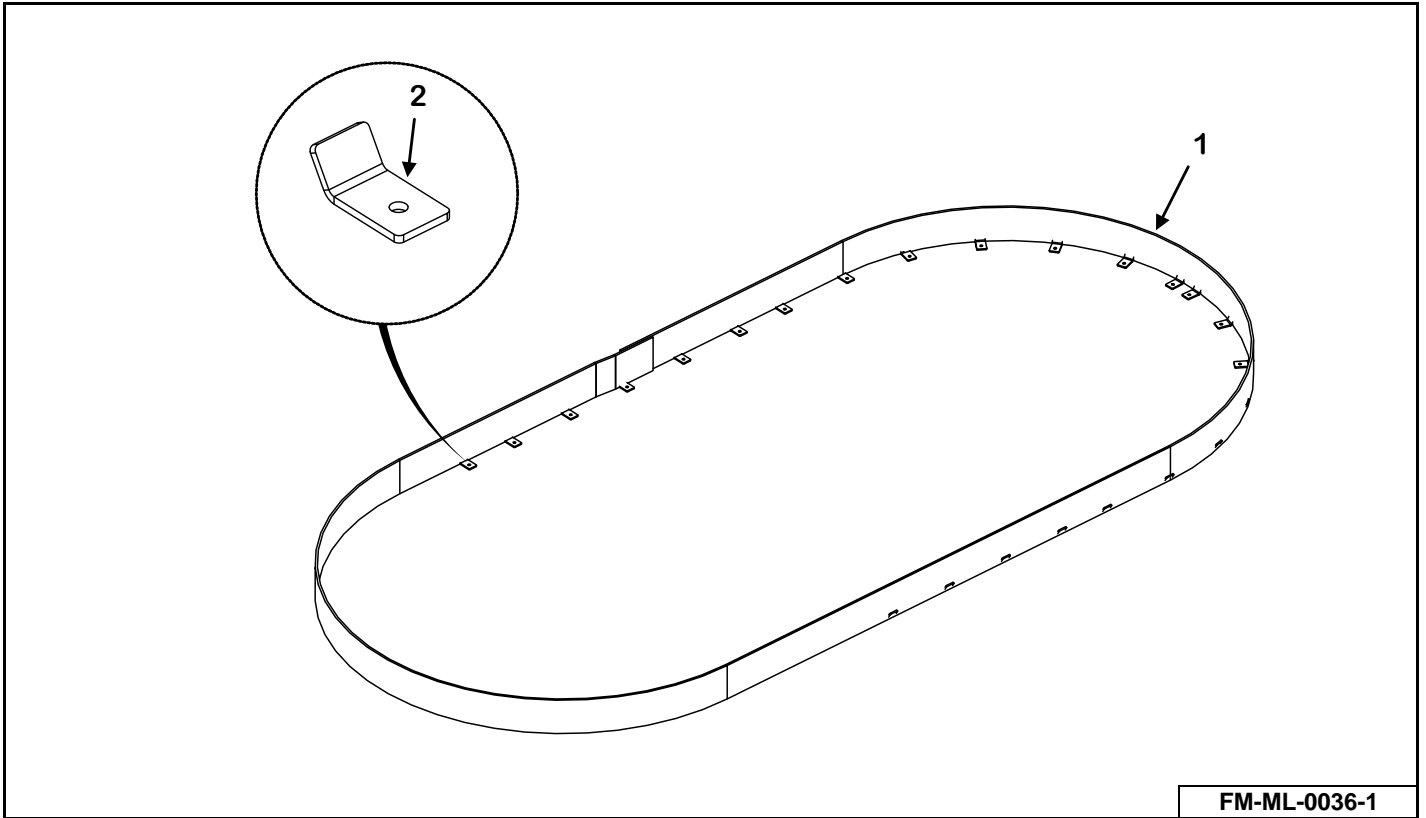

KEY	PART NUMBER	QTY	DESCRIPTION	MIXER MODEL
0	VA-0815-CE-8	1	8" Capacity Extension Assembly	815
	VA-1015-CE-8	1	8" Capacity Extension Assembly	1015
	VA-1215-CE-8	1	8" Capacity Extension Assembly	1215
1	M11-8-0001	1	8" Capacity Extension .453" x 8" x 53-1/2 FT	815
	M11-10-0001	1	8" Capacity Extension .453" x 8" x 55 FT	1015
	M11-12-0001	1	8" Capacity Extension .453" x 8" x 56 FT	1215
	805-0038-Z	4	3/8" Flat Washer	815 - 1215
	815-3816-Z	2	3/8"-16 Nylon Insert Lock Nut	815 - 1215
	851-3816-1.25Z	2	3/8"-16 x 1-1/4" Grade 5 Machine Bolt	815 - 1215
2	M4-1-8-0006	38	Belt Extension Mounts	815 - 1215
	805-0050-Z	38	1/2" Flat Washer	815 - 1215
	814-5013-Z	38	1/2"-13 Indented Lock Nut	815 - 1215
	851-5013-1.5Z	38	1/2"-13 x 1-1/2" Grade 5 Machine Bolt	815 - 1215

TIP OFF FRONT INCLINE DISCHARGE (CHAIN ONLY) & SIDE DISCHARGE

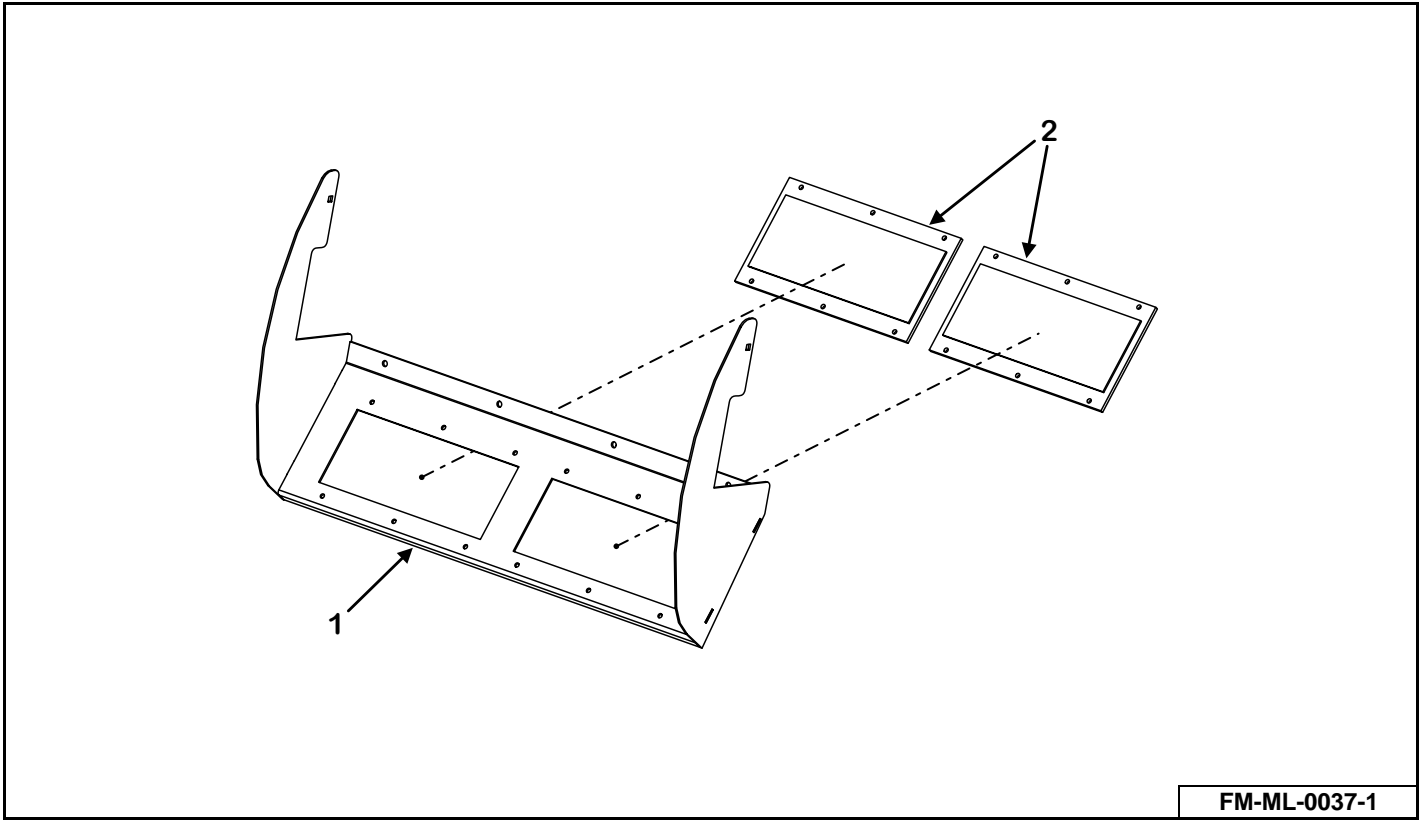

KEY	PART NUMBER	QTY	DESCRIPTION	MIXER MODEL
1	M3-1-12-0005	1	Side Discharge Conveyor Tip Off Weldment	1015/1215
	810-3816-Z	8	3/8" Spin Lock Nut	1015/1215
	851-3816-.75Z	6	3/8-16 x 3/4" Bolt	1015/1215
	850-3816-.75Z	2	3/8-16 x 3/4" Bolt	1015/1215
2	M11-1-0009	2	18.5" Discharge Magnet	1015/1215
	802T-3118-.75Z	16	5/16-18 x 3/4" Truss Head Machine Screw	1015/1215
	810-3118-Z	16	5/16-18 Spin Lock Nut	1015/1215

SIDE DISCHARGE SLIDE TRAY

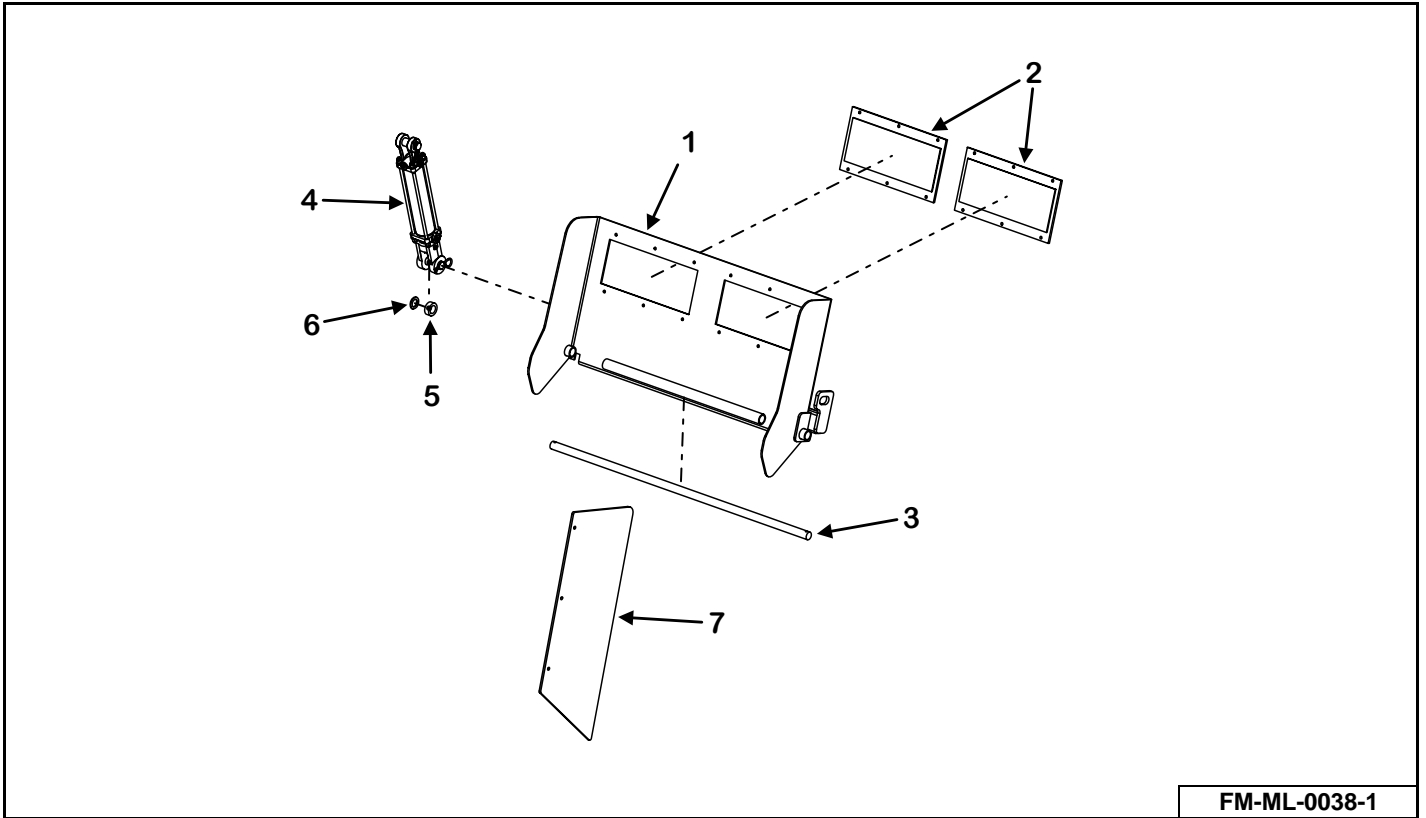

FM-ML-0038-1

KEY	PART NUMBER	QTY	DESCRIPTION	MIXER MODEL
1	M3-1-12-0006	1	42" Slide Tray Weldment With Magnet Cutouts	815 - 1215
	M3-1-12-0022-1	1	42" Slide Tray Weldment Without Magnet Cutouts	815 - 1215
	M3-1-12-0022	1	42" Slide Tray Weldment Without Magnet Cutouts (Includes Item 3)	815 - 1215
2	M11-1-0009	2	18-1/2" Discharge Magnet	815 - 1215
	802T-3118-.75Z	16	5/16"-18 x 3/4" Screw	815 - 1215
	810-3118-Z	16	5/16"-18 Spin Lock Nut	815 - 1215
3	M3-1-12-0008	1	Chute Pivot Rod 1" x 47-3/4"	815 - 1215
4	155-2-8-1.125-1	1	2" x 8" x 1-1/8" Hydraulic Cylinder #8 SAE Ports	815 - 1215
5	33-0309	1	Cylinder Pin Spacer	815 - 1215
6	808-1-1.5-10-Z	1	10GA 1" ID x 1-1/2" OD MB	815 - 1215
7	M3-1-4-0044	1	Slide Tray Deflector Belting	815 - 1215
	805-0038-Z	3	3/8" Flat Washer	815 - 1215
	815-3816-Z	3	3/8"-16 Nylon Insert Lock Nut	815 - 1215
	850-3816-1Z	3	3/8"-16 x 1" Bolt	815 - 1215

SLIDE TRAY HYDRAULIC SCHEMATIC

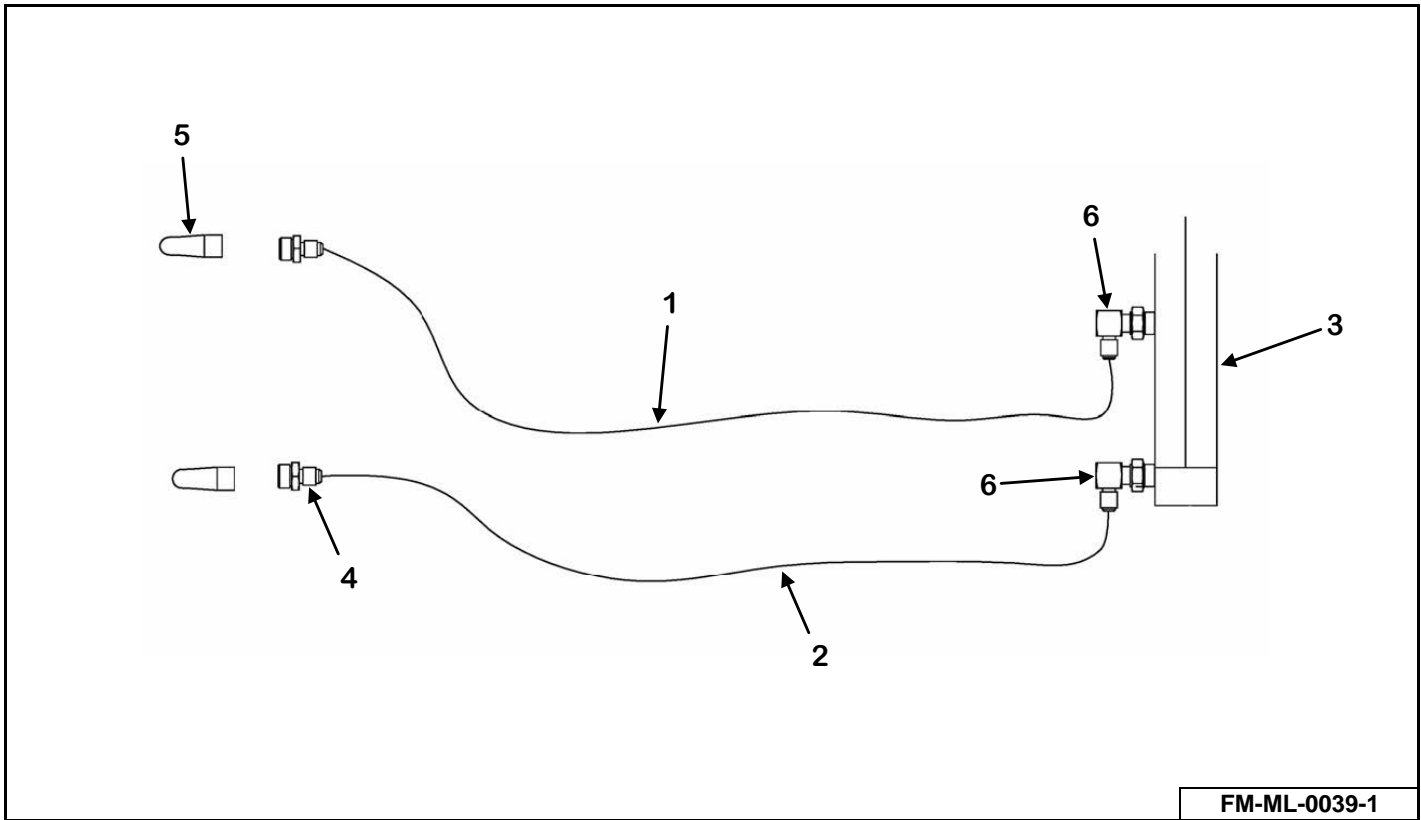

KEY	PART NUMBER	QTY	DESCRIPTION	MIXER MODEL
1	155-04R17-251-1	1	1/4" x 251" Hose Assembly	815 - 1215
2	155-04R17-240-1	1	1/4" x 240" Hose Assembly	815 - 1215
3	155-2-8-1.125-1	1	2" x 8" x 1-1/8" Hydraulic Cylinder	815 - 1215
4	155-6400-6-8	2	#6 JIC Male, #8 ORB Male Straight Connector	815 - 1215
5	155-8010-15	2	#8 ORB Male Tip 1/2" Body Size	815 - 1215
6	155-6801-6-8	1	#6 JIC Male, #8 ORB Male Adjustable 90°	815 - 1215

DRUM BRAKE ASSEMBLY

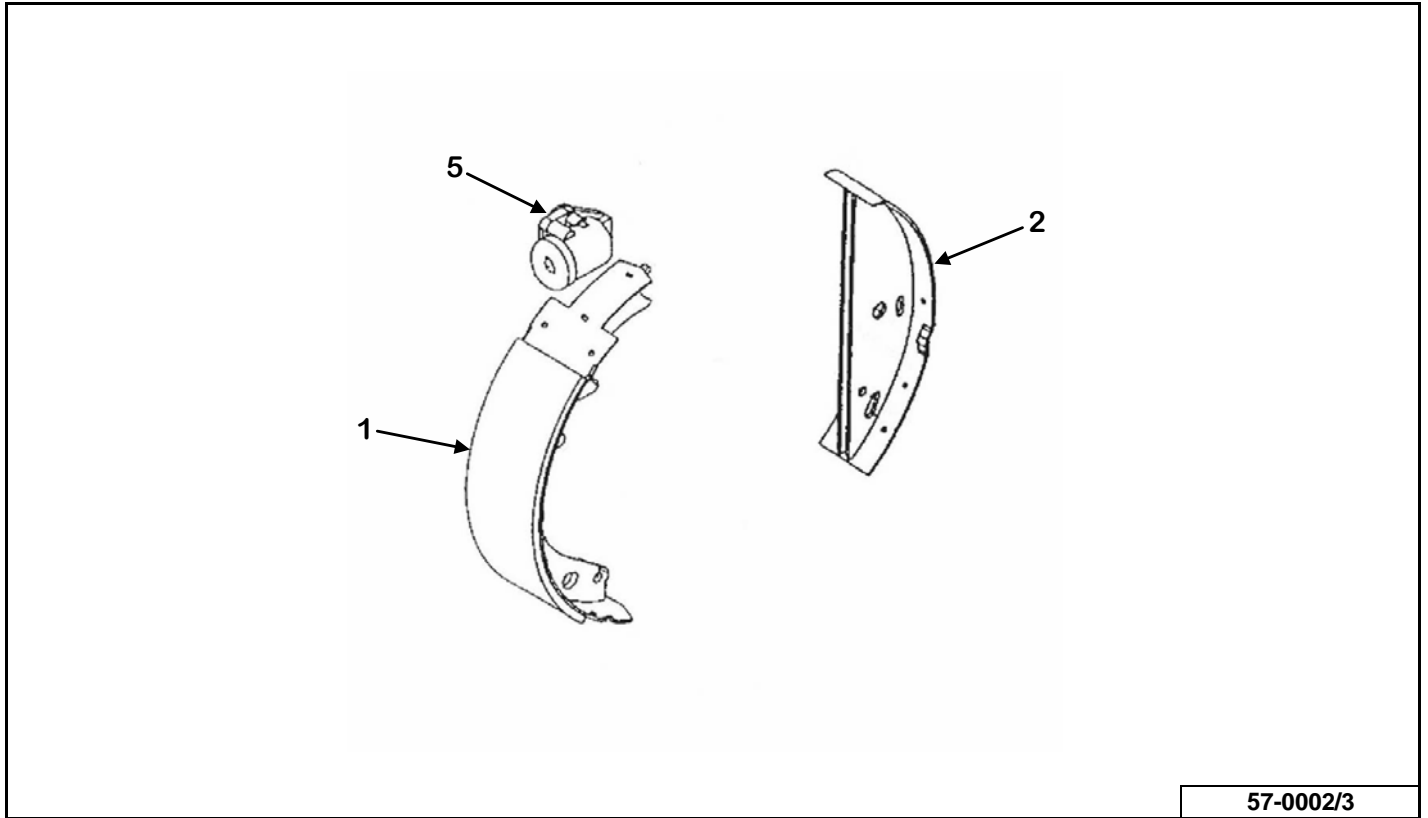

KEY	PART NUMBER	QTY	DESCRIPTION
0	57-0002	1	13" R.H. Free Backing Brake Assembly
	57-0003	1	13" L.H. Free Backing Brake Assembly
1	57-0002-5	1	Shoe Assembly
2	57-0002-3	1	Brake Shoe Assembly
3	57-0003-1	1	Wheel Cylinder Assembly Left
	57-0002-1	1	Wheel Cylinder Assembly Right (Not Shown)

HAND/FOOT BRAKE CONTROL ACTUATOR ASSEMBLY

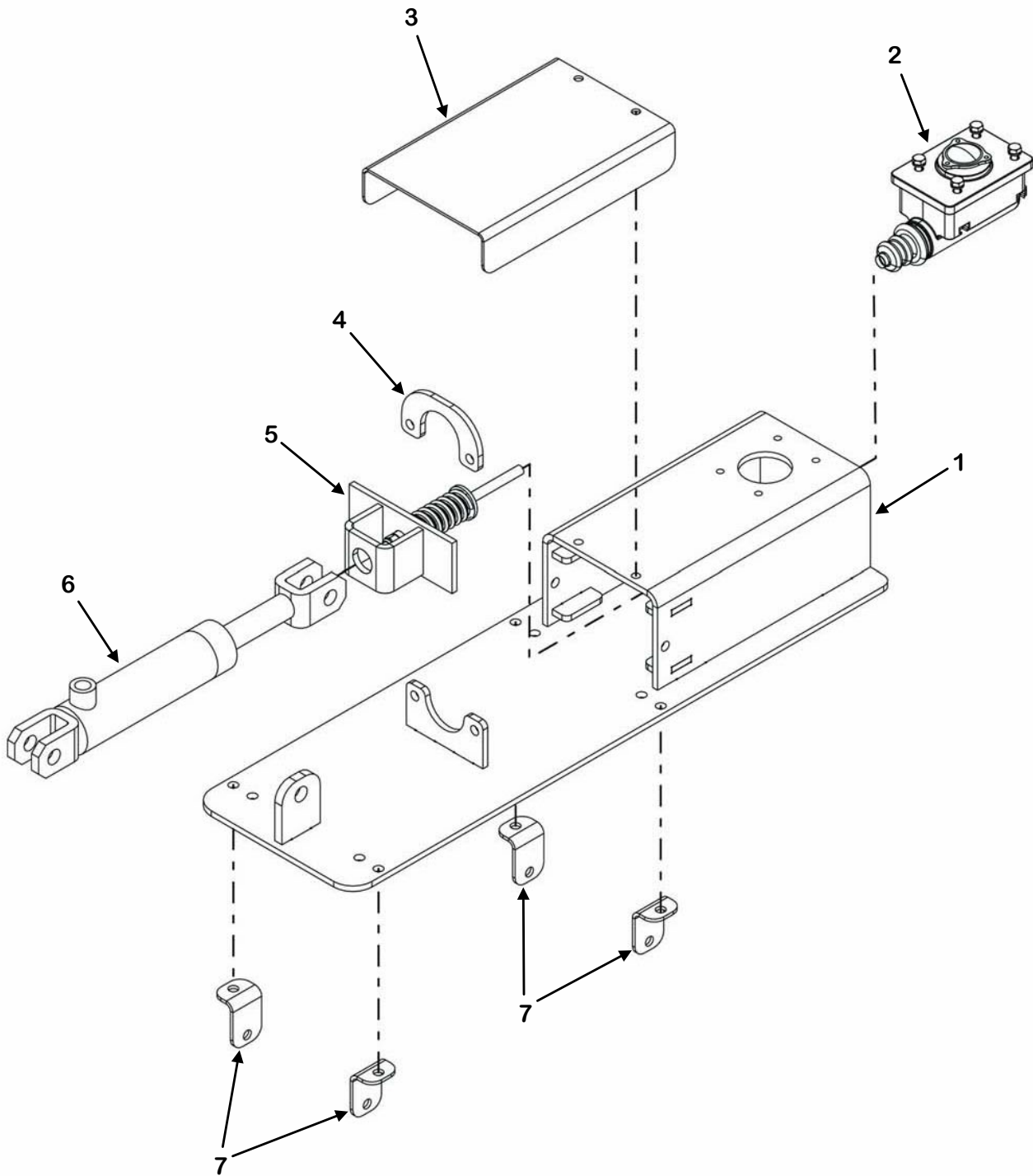

75-2230

KEY	PART NUMBER	QTY	DESCRIPTION
0	75-2230	1	Hand/Foot Control Brake Actuator Assembly
1	75-2230-1	1	Brake Actuator Mount Weldment
2	57-2000-4	1	Master Cylinder Assembly
3	75-2230-3	1	Brake Actuator Cover
4	75-2230-1-5	1	Brake Actuator Cylinder Mount Plate
5	57-2000-1	1	Push Plate Assembly
6	955-3772-SPO	1	Brake Hydraulic Cylinder
7	75-2230-1-6	4	Brake Actuator Mount Angle

SINGLE AXLE HYDRAULIC BRAKE SCHEMATIC

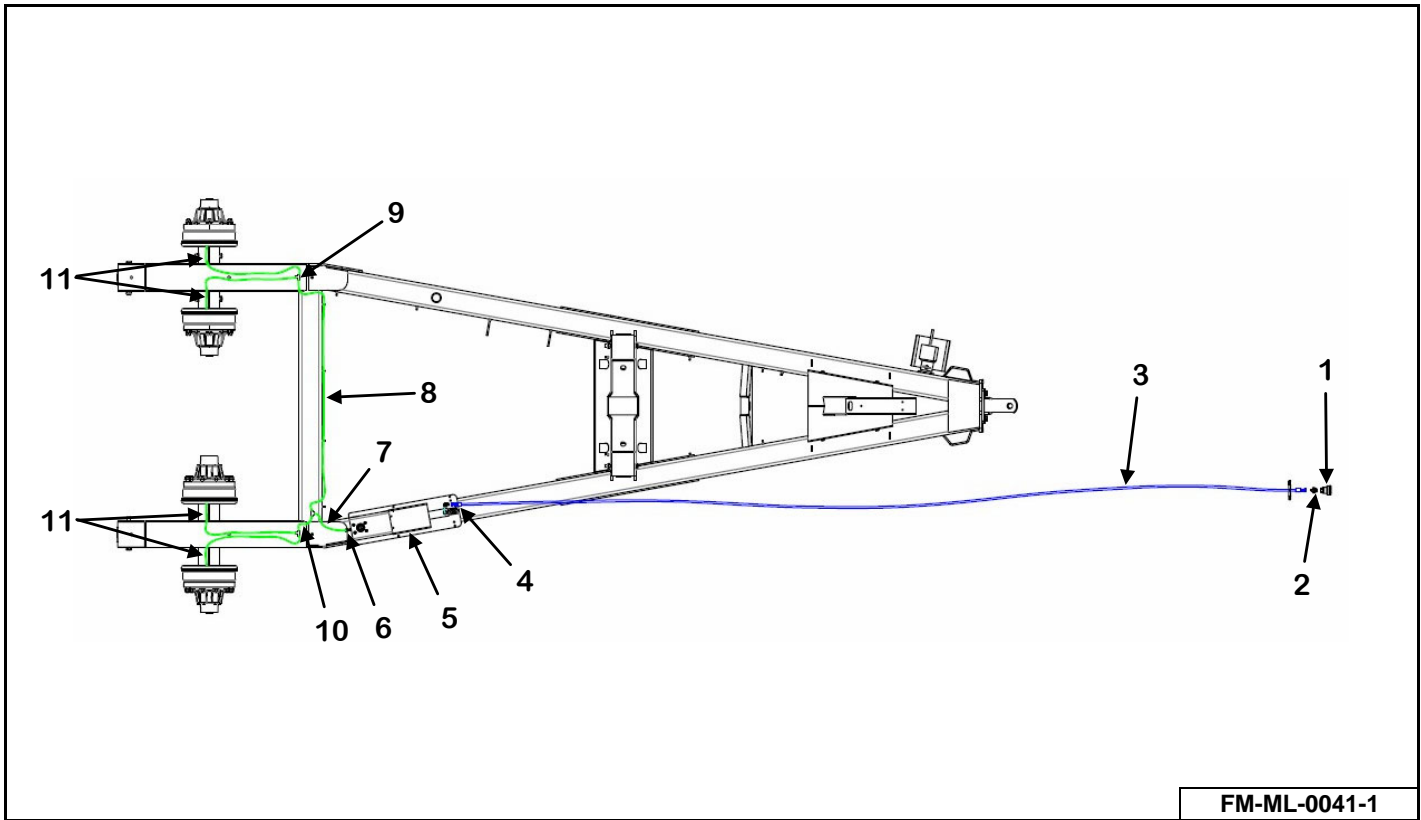

KEY	PART NUMBER	QTY	DESCRIPTION	MIXER MODEL
1	55-0212	1	Female Flat Face Coupler	1215
2	155-9002-6-8	1	Adapter	1215
3	155-04R17-218-1	1	1/4" x 218" Hose Assembly	1215
4	155-2501-06-04	1	90° Adapter	1215
5	See Page 218	1	Hand/Foot Control Brake Actuator Assembly	1215
6	57-0029-17	1	Inverted Flare Full Flow Orifice Fitting	1215
7	57-0071	1	12" Brake Line Assembly	1215
8	57-0020	1	90" Brake Line Assembly	1215
9	57-0013	3	Frame T With Clip	1215
10	57-0053	1	6" Brake Line Assembly	1215
11	57-0021	4	41" Brake Line Assembly	1215

TANDEM HYDRAULIC BRAKE SCHEMATIC

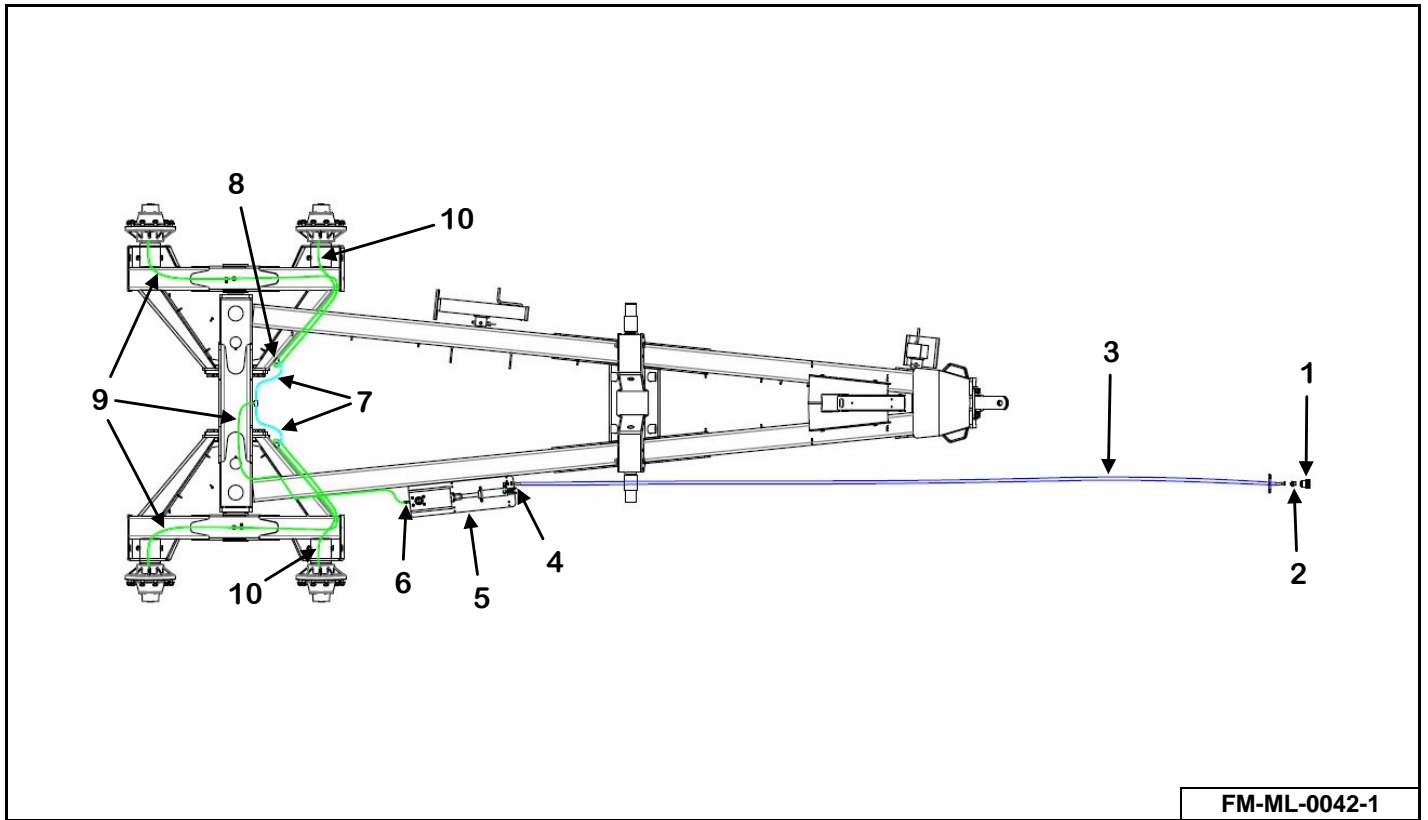

FM-ML-0042-1

KEY	PART NUMBER	QTY	DESCRIPTION	MIXER MODEL
1	55-0212	1	Female Flat Face Coupler	1215
2	155-9002-6-8	1	Adapter	1215
3	155-04R17-208-1	1	1/4" x 208" Hose Assembly	1215
4	155-2501-06-04	1	90° Adapter	1215
5	See Page 218	1	Hand/Foot Control Brake Actuator Assembly	1215
6	57-0029-17	1	Inverted Flare Full Flow Orifice Fitting	1215
7	57-0010	2	18" Brake Line Assembly	1215
8	57-0013	3	Frame T With Clip	1215
9	57-0020	3	90" Brake Line Assembly	1215
10	57-0021	2	41" Brake Line Assembly	1215

REMOTE SCALE MOUNT

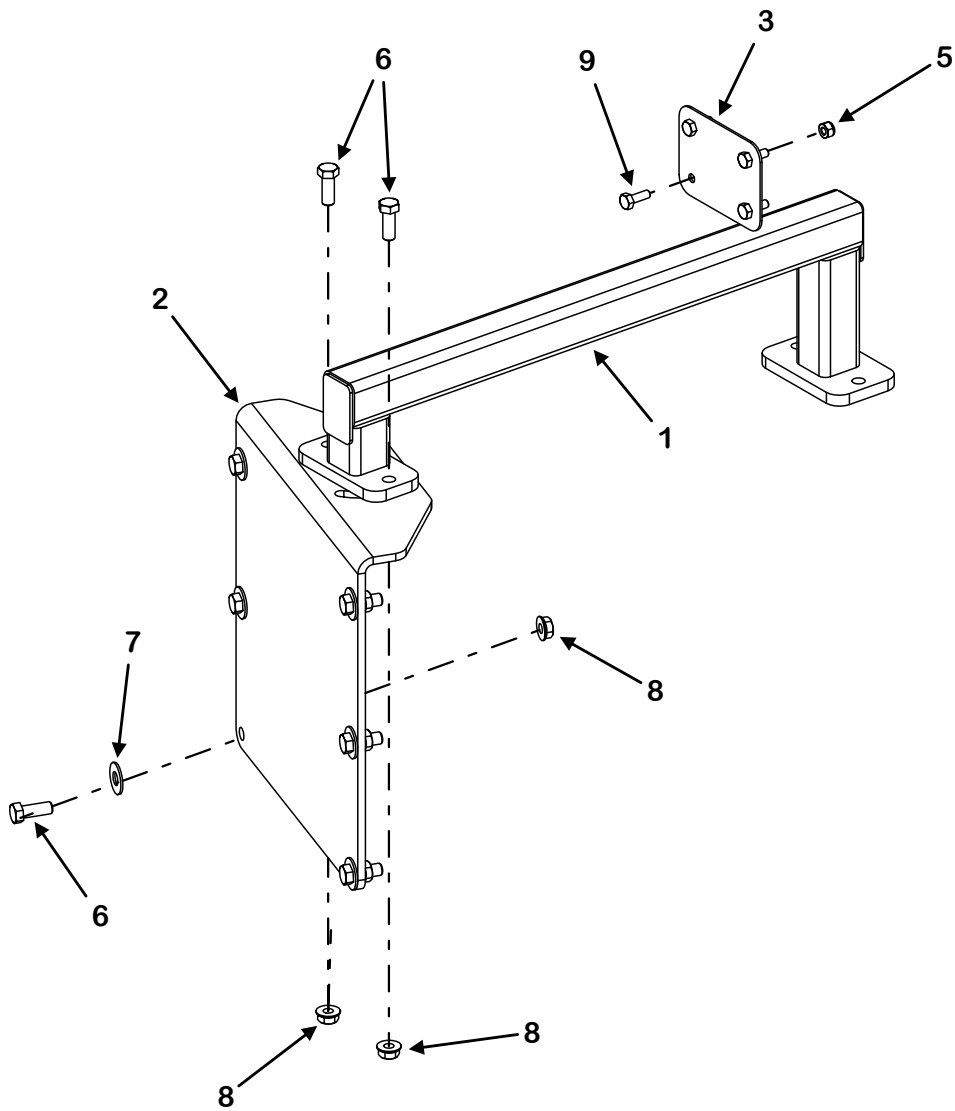

FM-ML-0043-1

KEY	PART NUMBER	QTY	DESCRIPTION	MIXER MODEL
0	VMSCM-405180	1	Remote Display Kit RD400 With TR Kit & 33' Cable/Visor	815 - 1215
	VMSCM-405200	1	Remote Display Kit RD400 With 33' Cable/Visor	815 - 1215
	VMSCM-407227	1	Remote Display Kit RD250 With 25' Cable	815 - 1215
1	M9-1-10-0001	1	Remote Scale Mount Bracket Weldment	815 - 1215
2	M9-1-10-0002	1	Remote Scale Mount Bracket	815 - 1215
3	M9-1-10-0003	1	Remote Scale Mount Belt Gusset	815 - 1215
4	58-0010-405180	1	RD4000 Remote Display Kit W/TR-33' Cable/Visor	815 - 1215
	58-0010-405200	1	RD4000 Remote Display Kit W/33' Cable/Visor	815 - 1215
5	815-2520-Z	4	1/4"-20 Nylon Insert Lock Nut	815 - 1215
6	851-3816-1Z	8	3/8"-16 x 1" Grade 5 Machine Bolt	815 - 1215
7	805-0038-Z	6	3/8" Flat Washer	815 - 1215
8	810-3816-Z	8	3/8" Spin Lock Nut	815 - 1215
9	851-2520-.75Z	4	1/4"-20 x 3/4" Grade 5 Machine Bolt	815 - 1215
NS	58-0010-1	1	Remote Cable, Y-Harness For Dual Remote	815 - 1215 (Optional)

RUBBER SIDE DOOR CHUTE ASSEMBLY

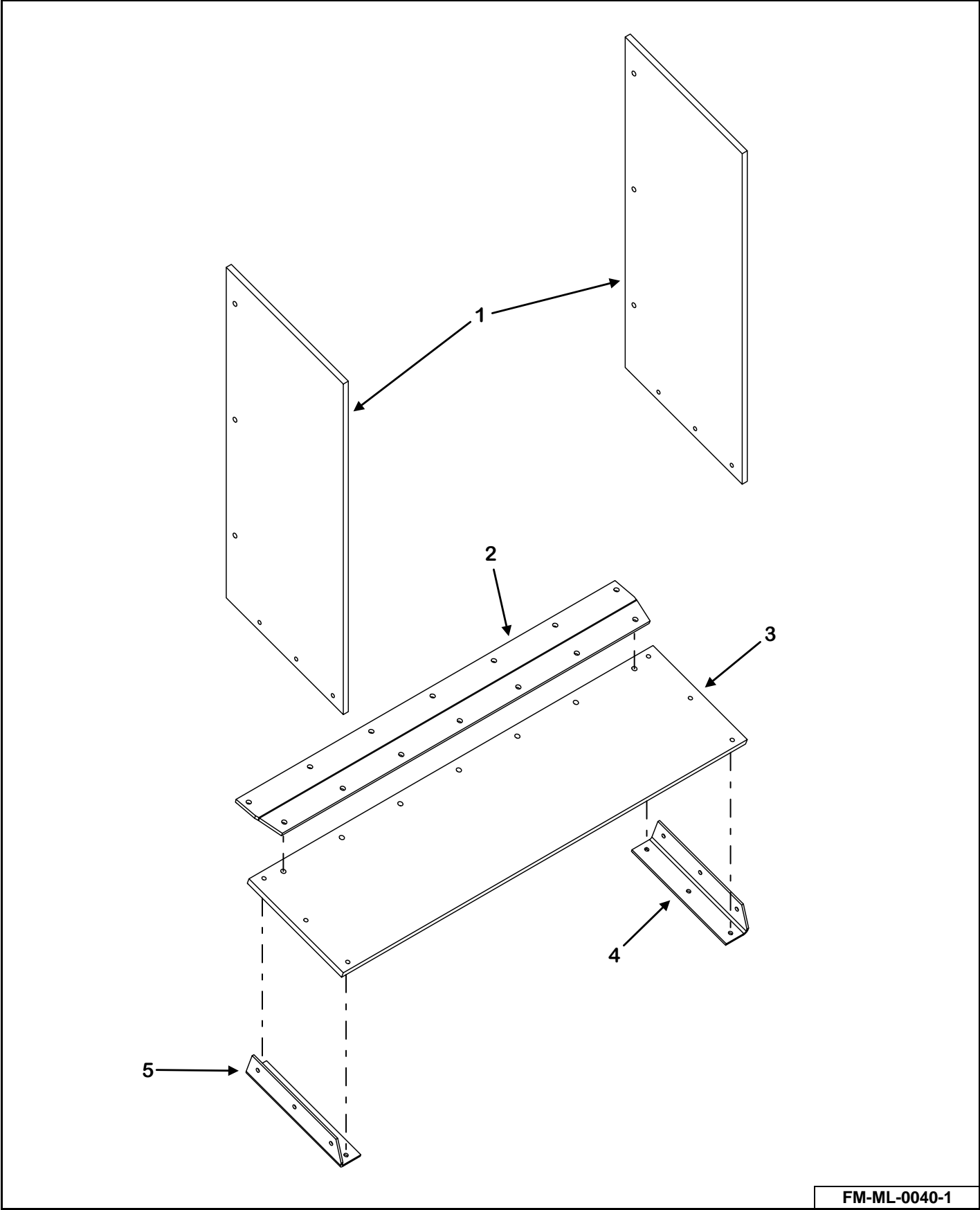

FM-ML-0040-1

KEY	PART NUMBER	QTY	DESCRIPTION	MIXER MODEL
0	VAML-SDBC-12	1	12" Side Door Belt Chute	815 - 1215
	VAML-SDBC-18	1	18" Side Door Belt Chute	815 - 1215
1	M11-5-0002-2	2	Chute Side Belt (12" Belt Chute)	815 - 1215
	M11-5-0002-2-18	2	Chute Side Belt (18" Belt Chute)	815 - 1215
2	M11-5-0002-5	1	Side Door Belt Chute Mount	815 - 1215
3	M11-5-0002-1	1	Chute Bottom Belt (12" Belt Chute)	815 - 1215
	M11-5-0002-1-18	1	Chute Bottom Belt (18" Belt Chute)	815 - 1215
4	M11-5-0002-4	1	Chute Corner Right Side Bracket (Facing Door) (12" Belt Chute)	815 - 1215
	M11-5-0002-4-18	1	Chute Corner Right Side Bracket (Facing Door) (18" Belt Chute)	815 - 1215
5	M11-5-0002-3	1	Chute Corner Left Side Bracket (Facing Door) (12" Belt Chute)	815 - 1215
	M11-5-0002-3-18	1	Chute Corner Right Side Bracket (Facing Door) (18" Belt Chute)	815 - 1215
NS	802T-2520-1Z	12	1/4"-20 x 1" Truss Head Machine Screw (12" Belt Chute)	815 - 1215
	802T-2520-1Z	20	1/4"-20 x 1" Truss Head Machine Screw (18" Belt Chute)	815 - 1215
NS	802T-3118-1.25Z	20	5/16"-18 x 1-1/4" Truss Head Machine Screw	815 - 1215
NS	805-0025-Z	12	1/4" Flat Washer (12" Belt Chute)	815 - 1215
	805-0025-Z	20	1/4" Flat Washer (18" Belt Chute)	815 - 1215
NS	805-0031-Z	13	5/16" Flat Washer	815 - 1215
NS	810-3118-Z	7	5/16"-18 Spin Lock Nut	815 - 1215
NS	815-2520-Z	12	1/4"-20 Nylon Insert Lock Nut (12" Belt Chute)	815 - 1215
	815-2520-Z	20	1/4"-20 Nylon Insert Lock Nut (18" Belt Chute)	815 - 1215
NS	815-3118-Z	13	5/16"-18 Nylon Insert Lock Nut	815 - 1215

CONVEYOR HANGING MAGNET & WEIGHT ASSEMBLY

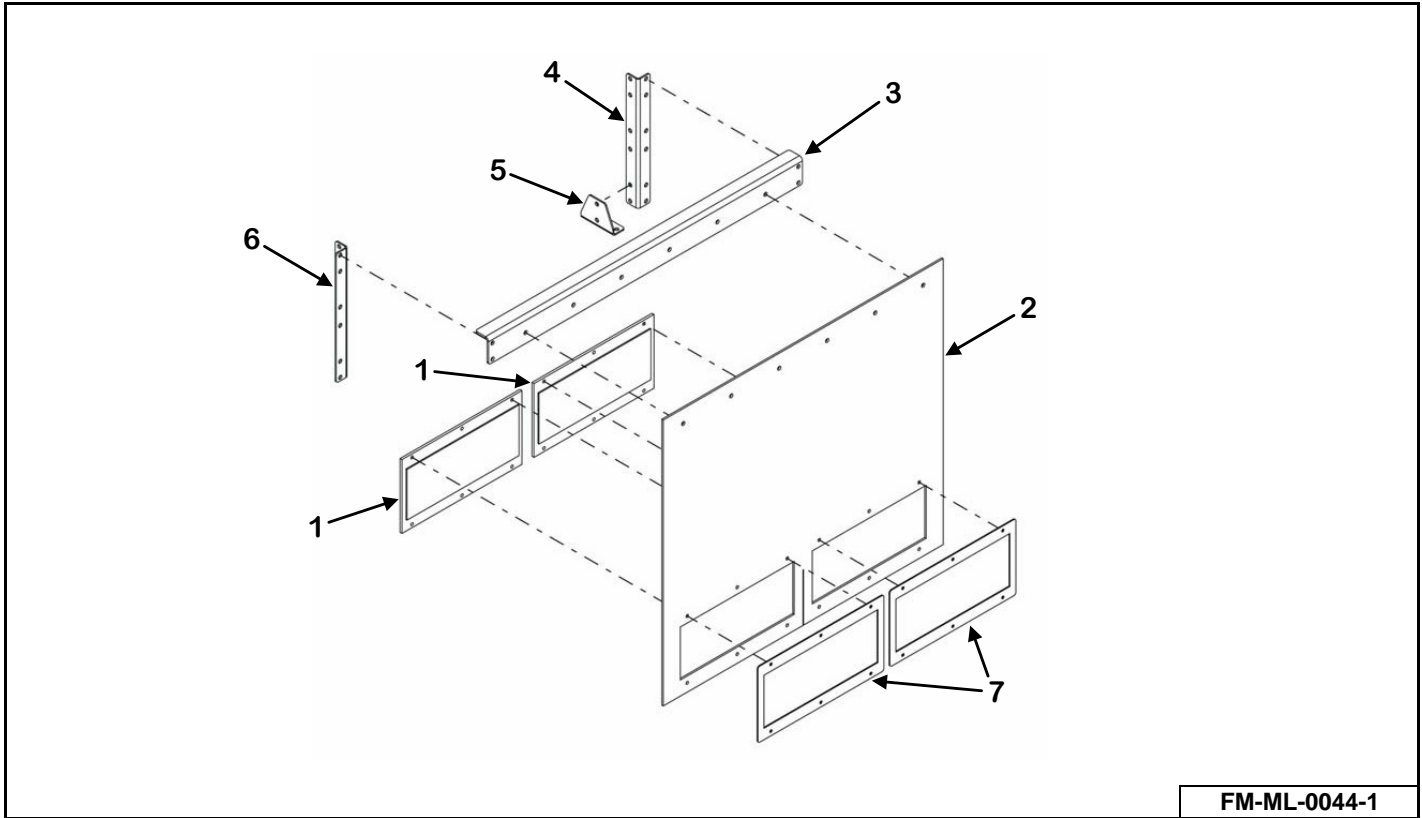

CONVEYOR DEFLECTOR ASSEMBLY

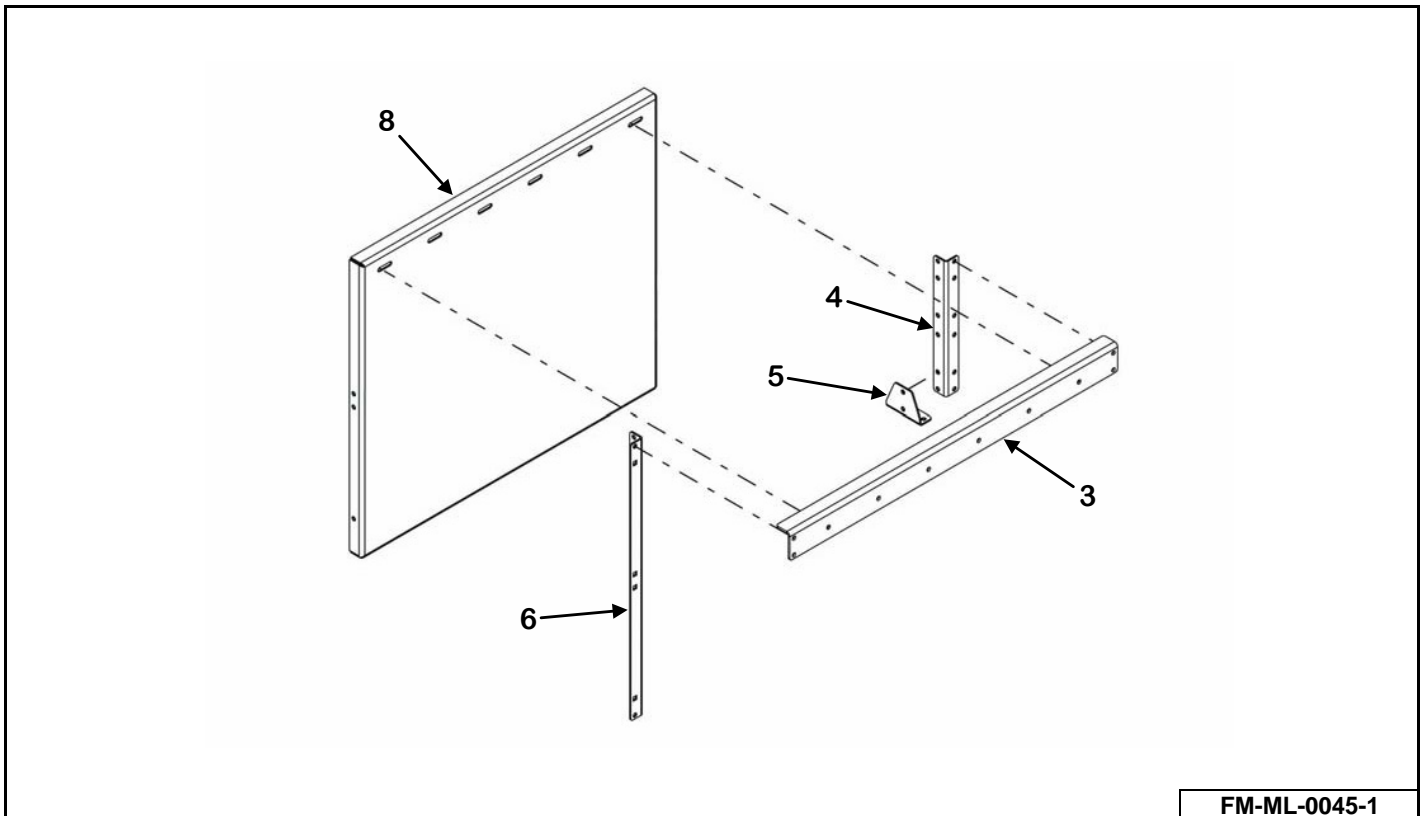

KEY	PART NUMBER	QTY	DESCRIPTION	MIXER MODEL
0	VAML-HMB-F	1	Hanging Magnet Kit For Left / Right Discharge (Front Flat Belt Conveyor)	815 - 1215
	VAML-HMB-I	1	Hanging Magnet Kit For Left / Right Discharge (Front Incline Belt Conveyor)	815 - 1215
	VAML-HDB-F	1	Hanging Weight Kit For Left/Right Discharge (Front Flat Belt Conveyor)	815 - 1215
	VAML-HDB-I	1	Hanging Weight Kit For Left/Right Discharge (Front Incline Belt Conveyor)	815 - 1215
	VAML-DBD-F	1	Deflector Kit For Left/Right Discharge (Front Flat Belt Conveyor)	815 - 1215
	VAML-DBD-I	1	Deflector Kit For Left/Right Discharge (Front Incline Belt Conveyor)	815 - 1215
	VAML-HMC	1	Hanging Magnet Kit For Left/Right Discharge (Front Flat Chain Conveyor)	815 - 1215
1	M11-1-0004	2	15" Hanging Magnet	815 - 1215
	M11-1-0026	2	15" Hanging Weight Plate	815 - 1215
2	M11-1-0003-4	1	Magnet Belting	815 - 1215
3	M11-1-0003-1	1	Hanging Magnet Mount (Front Flat Belt Conveyor)	815 - 1215
	M11-7-0003	1	Hanging Magnet Mount (Front Flat Chain Conveyor)	815 - 1215
4	M11-1-0003-2	1	Magnet Mount Rear Support Upright (Front Flat Belt Conveyor)	815 - 1215
	M11-7-0002	1	Magnet Mount Rear Support Upright (Front Incline Belt Conveyor)	815 - 1215
	M11-7-0004	1	Magnet Mount Rear Support Upright (Front Flat Chain Conveyor)	815 - 1215
5	M11-1-0003-3	1	Magnet Support Mount	815 - 1215
6	M11-1-0003-2	1	Magnet Mount Front Support Upright (Front Flat Belt Conveyor) Prior to SN 17VM(0815202, 1015205, 1215204)	815 - 1215
	M11-7-0002	1	Magnet Mount Front Support Upright (Front Flat & Incline Belt Conveyor) SN 17VM(0815202, 1015205, 1215204) & Later	815 - 1215
	M11-7-0002	1	Magnet Mount Front Support Upright (Front Flat Chain Conveyor)	815 - 1215
7	M11-1-0003-4-1	2	Hanging Magnet/Weight Backer Plates	815 - 1215
8	M11-1-0003-5	1	Deflector Plate (Belt Conveyor Only)	815 - 1215

POWER MAGNET

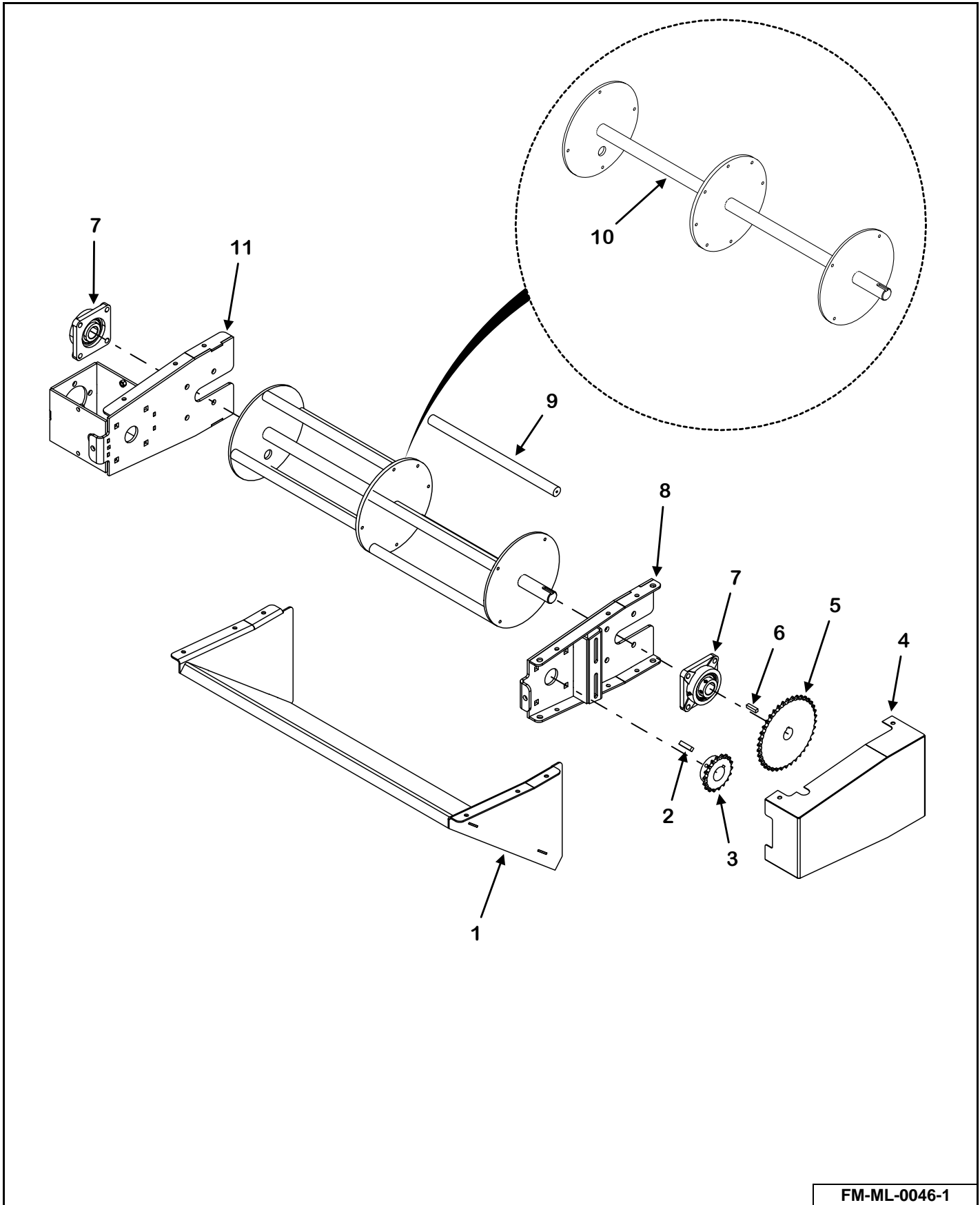

FM-ML-0046-1

KEY	PART NUMBER	QTY	DESCRIPTION	MIXER MODEL
0	VAML-PRM-FDI- KIT	1	Medium/Large Family Power Magnet Flat Conveyor Kit	815 - 1215
1	M3-1-10-0028	1	Deflector Weldment	815 - 1215
2	35-0010	1	3/8" x 3/8" x 1-1/2" Square Key	815 - 1215
3	110-50B18-1.5-1	1	50B18 1-1/2" Sprocket	815 - 1215
4	M3-1-10-0029-1	1	Shield Weldment	815 - 1215
5	110-50B38-1.25-1	1	50B38 1-1/4" Sprocket	815 - 1215
6	35-0030-H	1	5/16" x 5/16" x 1-1/4" Square Key	815 - 1215
7	14-0101	2	1-1/4" 4-Bolt Bearing	815 - 1215
8	M3-1-10-0025	1	Bearing Mount Weldment	815 - 1215
9	M3-1-8-0020-4	8	Magnet Tube	815 - 1215
10	M3-1-8-0020-1	1	Spinner Weldment	815 - 1215
11	M3-1-10-0026	1	Motor Mount Weldment	815 - 1215



11.0 SPECIFICATIONS

815 / 1015 / 1215 DIMENSIONS			
	815	1015	1215
Overall Length - Side Door / Front Door	296" / 326"	300" / 330"	304" / 334"
Mixing Chamber Length	254"	261"	269"
Overall Height - Tire Option Used	385/65R-22.5	385/65R-22.5	385/65R-22.5
Overall Height - Base Machine	105"	117"	130"
Overall Height - Belt Extensions	111"	123"	136"
Overall Height - Hay Retention Ring	111"	123"	136"
Tread Width	105"	105"	105"
Transport Width - Front Conveyor / Side Conveyor - W/ 36" Ext.	116" / 131"	117" / 132"	118" / 133"
Max Discharge Reach - Front Cross Conveyor - Flat	9" / 0"	9" / 0"	9" / 0"
Max Discharge Reach - Front Cross Conveyor - Incline 24" / 36" / 48" (In Down Position)	13" / 25" / 36"	13" / 25" / 36"	13" / 25" / 36"
Max Discharge Reach - Side Conveyor - 24" / 36" / 48" / 60" / 72" (In Down Position)	35" / 46" / 57" / 68" / 79"	35" / 46" / 57" / 68" / 79"	35" / 46" / 57" / 68" / 79"
Max Discharge Reach - Side Slide Tray	18"	18"	18"
Max Discharge Reach - Side Belt Extension	15"	15"	15"
Max Discharge Height - Front Cross Conveyor - Flat	41"	41"	41"
Max Discharge Height - Front Cross Conveyor - Incline 24" / 36" / 48" (In Down Position)	41" / 44" / 47"	41" / 44" / 47"	41" / 44" / 47"
Max Discharge Height - Side Conveyor - 24" / 36" / 48" / 60" / 72" (In Down Position)	41" / 45" / 49" / 54" / 58"	41" / 45" / 49" / 54" / 58"	41" / 45" / 49" / 54" / 58"
Max Discharge Height - Side Slide Tray	25"	25"	25"
Max Discharge Height - Side Belt Extension	32"	32"	32"

815 / 1015 / 1215 SPECIFICATIONS

	815	1015	1215
Mixing Capacity - No Extension	818 Cu. Ft.	1016 Cu. Ft.	1215 Cu. Ft.
Mixing Capacity - Extensions	910 Cu. Ft.	1112 Cu. Ft.	1315 Cu. Ft.
Unit Weight - Front Discharge - lbs (Option Sensitive)	N/A	N/A	~23,620
Unit Weight - Side Discharge - lbs (Option Sensitive)	~18,100	~20,800	~22,660
Maximum Net Load - lbs	27,300	33,360	39,450
Auger Qty.	2	2	2
Auger Diameter	107"	107"	107"
Auger Speed - Standard / High Speed	27 / 40 RPM	27 / 40 RPM	27 / 40 RPM
Auger - Upper Flighting Thickness	5/8"	5/8"	5/8" Heat Treated
Auger - Lower Flighting Thickness	3/4"	3/4"	3/4" Heat Treated
Auger - Knives - Adjustable - Per Auger	6	7	7
Planetary Drive	Straight-Drive	Straight-Drive	Straight-Drive
PTO Drive	1000 RPM	1000 RPM	1000 RPM
Drive Protection	Torque-Disconnect	Torque-Disconnect	Torque-Disconnect
Discharge Door Opening - Front	46" x 40"	46" x 40"	46" x 40"
Discharge Door Opening - Side	42" x 40"	42" x 40"	42" x 40"
Discharge Door Opening - Rear	46" x 40"	46" x 40"	46" x 40"
Discharge - Conveyor Width - Front / Side	36" x 42"	36" x 42"	36" x 42"
Discharge - Front Cross Conveyor Travel - Left or Right	8"	8"	8"
Tub / Trailer - Floor Thickness	3/4"	3/4"	1"
Tub / Trailer - Sidewall Thickness	1/4"	1/4"	1/4"
Tub / Trailer - Trailer or Subframe	Single-Axle	Single-Axle	Single-Axle
Tub / Trailer - Spindle Diameter	3-1/2"	3-1/2"	4-1/2"
Tub / Trailer - Scale System	4-Point	4-Point	4-Point
Tongue Weight - % Gross	10%	10%	10%
Tractor Requirement - PTO HP	140	160	200

FEATURES			
	815	1015	1215
Twin Mixing Augers	STD	STD	STD
Replaceable Scrapers	STD	STD	STD
Hardened Knives	STD	STD	STD
Hay Stops	STD	STD	STD
Ladder	STD	STD	STD
Jack Stand	STD	STD	STD
Torque Disconnect PTO's	STD	STD	STD
Stop & Shift Gearbox (Electric Shift)	STD	STD	STD
Power Shift Transmission (Electric Shift)	STD	STD	STD
Straight Drive	N/A	N/A	N/A
Heavy-Duty Gearboxes	STD	STD	STD
Single Axle Trailer	STD	STD	STD

OPTIONS			
	815	1015	1215
Tandem Axle Trailer	OPT	OPT	OPT
Side Discharge Door Right/Left	OPT	OPT	OPT
Front Discharge Door	OPT	OPT	OPT
Rear Discharge Door	OPT	OPT	OPT
Front Cross Conveyor	OPT	OPT	OPT
Side Door Conveyor	OPT	OPT	OPT
Viewing Platform	OPT	OPT	OPT
Slide Tray	OPT	OPT	OPT
Safety Chain	OPT	OPT	OPT
Magnets	OPT	OPT	OPT
Hay-Retention Ring	OPT	OPT	OPT
Capacity Belt Extension	OPT	OPT	OPT
Hardened Knives (Additional)	OPT	OPT	OPT
Tank Liner	OPT	OPT	OPT
Baffle Liner	OPT	OPT	OPT



**Manufactured by:
Meyer Manufacturing
Corporation**

674 W. Business Cty Rd A

Dorchester, WI 54425

Phone. 1-800-325-9103

Fax: 715-654-5513

Email: parts@meyermfg.com

Website: www.meyermfg.com