

PB-MIXER-M-19



FORMULA MIXER

585 • 700 • F2-585 • F2-700

Owner/Operator's Manual
&
Parts Book

Starting 2019 Model Year



3/13/2025

1.0 IMPORTANT INFORMATION

The mixer serial number plate is located on the front left hand side of the mixing tub.

The trailer serial number plate is located on the left hand side of the trailer hitch.

Please enter the model, serial number and additional information in the space provided for future reference.



**Mixer Body
Serial Number**

Model No. _____

Mixer Serial No. _____

Trailer Serial No. _____

Date of Purchase _____

Dealership _____

Dealership Phone No. _____



**Trailer
Serial Number**

Always use your serial number when requesting information or when ordering parts.

HOW TO READ THE SERIAL NUMBER

MIXER

EXAMPLE: 19VM0700201

Model Year / Vertical Mixer / Model / Sequence Of Build



19



VM



0700



201

TRAILER

EXAMPLE: VMT19201

Vertical Mixer Trailer / Model Year / Sequence Of Build



VMT



19



201

Meyer Manufacturing Corporation
674 W. Business Cty Rd A
Dorchester, WI 54425
Phone: 1-800-325-9103
Fax: 715-654-5513
Email: parts@meyermfg.com
Website: www.meyermfg.com



2.0 PRE-DELIVERY & DELIVERY CHECK LIST

MEYER MANUFACTURING CORPORATION

Phone: 715-654-5132 • Toll-Free: 1-800-325-9103 • P.O. Box 405 • Dorchester, WI 54425

This Pre-Delivery & Delivery Check List must be gone through by the Selling Party and the Customer to validate the Owner's Registration Form.

PRE-DELIVERY CHECK LIST

After the new Meyer Mixer has been completely set-up, check to be certain it is in correct running order before delivering it to the customer.

The following is a list of points to inspect:

Check off each item as you have made the proper adjustments and found the item operating satisfactorily. Any adjustments made, MUST be according to specifications defined in this manual.

- All shields and guards are in place and securely fastened.
- All PTO shields turn freely.
- All bolts and other fasteners are secure and tight.
- All mechanisms operate trouble free.
- All grease fittings have been lubricated, gear boxes filled to proper levels and all roller chains are oiled. Refer to 8.2 LUBRICATION.
- Conveyor Belt or Chain are at proper tension. Refer to 8.3 ADJUSTMENTS.
- All stop/tail/turn lights work properly.
- All decals are in place and legible.

DELIVERY CHECK LIST

The following check list is an important reminder of valuable information that MUST be passed on to the customer at the time the unit is delivered.

Check off each item as you explain it to the customer.

- Explain to the customer that pre-delivery check list was fully completed.
- Give customer the Owner & Operator's Manual. Instruct to read and completely understand its contents BEFORE attempting to operate the mixer.
- Explain and review with customer the new Meyer implement manufacturer's warranty.
- Show the customer where to find the serial number on the implement.
- Explain and review with the customer the 5.1 SAFETY PRECAUTIONS.
- Explain and review with customer the proper "Start-up and Operating Procedures" sections of this manual.
- Demonstrate the PTO Shaft Locking Device and proper PTO shaft storage. Also, demonstrate proper hydraulic hose storage and tip holder used to keep system clean from contaminants.
- Explain that regular lubrication and proper adjustments are required for continued proper operation and long life of the mixer. Review with the customer the 8.2 LUBRICATION and 8.3 ADJUSTMENTS sections of this manual.
- Explain the importance of conveyor chain or belt tension, and the need to watch and adjust during the break-in period.
- Fully complete this PRE-DELIVERY & DELIVERY CHECK LIST with the customer.



3.0 INTRODUCTION

Congratulations on your purchase of a new Meyer farm equipment product. Undoubtedly you have given much consideration to your purchase and we're proud that you have selected Meyer. Pride in craftsmanship, engineering and customer service have made Meyer products the finest in the farm equipment industry today.

There is no substitute for quality. That is why thousands of people like you have purchased Meyer farm equipment. They felt it was the best equipment to serve their farming needs, now and in years to come. We ask that you follow our policy of "safety first", and we strongly suggest that you read through the "Owner / Operator's Manual & Parts Book" before operating your Meyer farm equipment. Meyer Manufacturing Corporation wants to thank you for not compromising quality. We are determined to offer excellence in customer service as well as provide you with the very best value for your dollar.

Sincerely,

All Employees of

MEYER MANUFACTURING CORPORATION

When the PTO is referred to, it means power take-off from the tractor.

The formula mixer may be referred to as mixer, implement, equipment or machine in this manual.



IMPORTANT: You are urged to study this manual and follow the instructions carefully. Your efforts will be repaid in better operation and service as well as a savings in time and repair expense. Failure to read this manual and understand the machine could lead to serious injury. If you do not understand instructions in this manual, contact either your dealer or Meyer Manufacturing Corp. at Dorchester, WI 54425.



WARRANTY: At the front of this manual is an "Owner's Registration Form". Be sure your dealer has completed this form and promptly forwarded a copy to Meyer Manufacturing to validate the manufacturer's warranty. The product model and serial number are recorded on this form and on the inside of the front cover for proper identification of your Meyer implement by your dealer and the manufacturer when ordering repair parts. The mixer serial number plate is located on the front left hand side of the mixing tub. The trailer serial number plate is located on the left hand side of the hitch.



REPAIR PARTS: At the back of this manual is the repair parts section. All replacement parts are to be obtained from or ordered through your Meyer dealership. When ordering repair parts, refer to the parts section and give complete information including quantity, correct part number, detailed description and even model number and serial number of the implements which needs repair parts.

Manufacturer's Statement: Meyer Manufacturing Corporation reserves the right to make improvements in design, or changes in specifications at any time, without incurring any obligation to owners of units previously sold. This supersedes all previous published instructions.



4.0 MANUFACTURER'S WARRANTY

04/2014

MEYER FORMULA MIXER

- I The "Owner's Registration Form" must be completed in full and promptly returned to Meyer Mfg. Corp. for this warranty to become both valid and effective. All warranties on New Meyer Mixers shall apply only to the original retail customer from an authorized Meyer Mfg. Corp. dealership.
- II This warranty shall not apply to any Meyer Mixer which has been subjected to misuse, negligence, alteration, accident, incorrect operating procedures, has been used for an application not designed for or pre-authorized by Meyer in writing, has had the serial numbers altered, or which shall have been repaired with parts other than those obtained through Meyer Mfg. Corp. Meyer is not responsible for the following: Depreciation or damage caused by normal wear, lack of reasonable and proper maintenance, failure to follow the operator's manual recommendations or normal maintenance parts and service. Meyer is not responsible for rental of replacement equipment during warranty repairs, damage to a power unit (including but not limited to a truck or tractor), loss of earnings due to equipment down time, or damage to equipment while in transit to or from the factory or dealer.
- III Meyer Mfg. Corp. warrants New Meyer Mixer to be free from defects in material and workmanship under recommended use and maintenance service, as stated in the operator's and parts manuals, as follows:
 - A. Meyer Mfg. Corp. will repair or replace F.O.B. Dorchester, WI, as Meyer Mfg. Corp. elects, any part of a new Meyer Mixer which is defective in material or workmanship:
 - i Without charge for either parts or labor during the first (1) year from purchase date to the original retail customer.
 - B. In addition to the above basic warranty, Meyer Mfg. Corp. will repair or replace F.O.B. Dorchester, WI as Meyer Mfg. Corp. elects:
 - i Any part of the following which is defective in material or workmanship (not neglect to recommended use and service) with a "pro-rated" charge for parts only (not labor) during the stated time period from date of purchase to the original retail customer. 1st year 100%, 2nd year 100%, 3rd year 50%, 4th year 25%, 5th year 10%
 - a. The Formula Mixer Planetary Gearbox. Meyer Part #'s 119-1680-13.5-1, 119-1680-24.18-1, 119-18-13.92-1, 119-21-25.57-1, 119-32-24.8-1.
- IV COMMERCIAL USE: Coverage as in paragraph III.A.i. only, except warranty coverage is for (90) days for parts and labor to the original commercial retail customer.
- V Repairs eligible for labor warranty must be made by Meyer Mfg. Corp. or an authorized Meyer dealership. The original retail customer is responsible for any service call and/or transportation of the mixer to the dealership or the factory for warranty service.
- VI Except as stated above, Meyer Mfg. Corp. shall not be liable for injuries or damages of any kind or nature, direct, consequential, or contingent, to persons or property. This warranty does not extend to loss of crop or for any other reasons.
- VII No person is authorized to give any other warranties or to assume any other obligation on Meyer Mfg. Corp.'s behalf unless made or assumed in writing by Meyer Mfg. Corp. This warranty is the sole and exclusive warranty which is applicable in connection with the manufacture and sale of this product and Meyer Mfg. Corp.'s responsibility is limited accordingly.

Purchased Product Warranty:

This warranty does not apply to component parts not manufactured by Meyer such as but not limited to wheels, tires, PTO shafts, clutches, hydraulic cylinders, scales, etc.



TABLE OF CONTENTS

1.0	IMPORTANT INFORMATION	2
2.0	PRE-DELIVERY & DELIVERY CHECK LIST	3
3.0	INTRODUCTION	5
4.0	MANUFACTURER'S WARRANTY	7
5.0	SAFETY	15
5.1	SAFETY PRECAUTIONS	16
5.2	SAFETY SIGNS	18
5.3	SHUTOFF & LOCKOUT POWER	24
5.3.1	SHUTOFF & LOCKOUT POWER RECOMMENDATIONS	24
6.0	PRE-OPERATION	25
6.1	STATIC INSPECTION	25
6.2	LIGHT HOOK-UP	26
6.3	HYDRAULIC HOOK-UP	26
6.4	PTO DRIVELINE OPTION	26
6.5	TRACTOR DRAWBAR SETUP	28
6.6	HITCHING TO TRACTOR	29
6.6.1	JACK STORAGE	29
6.7	START-UP AND SHUT-DOWN	30
6.7.1	START-UP	30
6.7.2	SHUT-DOWN	30
6.8	OPERATIONAL CHECKS	31
6.8.1	CONTROLS	32
6.8.1.1	STOP & SHIFT GEARBOX	32
6.8.1.2	POWER SHIFT TRANSMISSION	32
6.9	TRANSPORTING	33
6.9.1	SAFETY CHAIN	34
6.9.2	TRACTOR TOWING SIZE REQUIREMENTS	35
6.10	DIGITAL SCALE INDICATOR	35

TABLE OF CONTENTS

7.0	OPERATION	37
7.1	GENERAL	37
7.1.1	MATERIAL.....	38
7.1.2	CUTOUT CLUTCH	38
7.2	LOADING	39
7.2.1	LOADING SEQUENCE	40
7.3	MIXING.....	41
7.3.1	MIXING TROUBLESHOOTING GUIDE	41
7.4	PLATFORM OPERATION.....	42
7.5	FOLDING LADDER	42
7.6	UNLOADING	43
7.7	UNHOOKING THE TRACTOR.....	44
7.8	HAY STOP ADJUSTMENT	45
7.8.1	HAY STOP LOCK BOLT	45
8.0	MAINTENANCE	47
8.1	GENERAL	47
8.2	LUBRICATION	47
8.2.1	DAILY LUBRICATION	48
8.2.2	EVERY 8 HOURS.....	50
8.2.3	WEEKLY LUBRICATION.....	51
8.2.4	MONTHLY LUBRICATION.....	51
8.2.5	EVERY 40 HOURS.....	52
8.2.6	FIRST 50 HOURS	52
8.2.7	EVERY 250 HOURS.....	52
8.2.8	SEMIANNUALLY OR EVERY 500 - 600 HOURS (WHICHEVER IS FIRST)	54
8.2.9	ANNUALLY.....	54
8.2.10	ANNUALLY OR EVERY 1000 HOURS (WHICHEVER IS FIRST)	54
8.2.11	ANNUALLY OR EVERY 2000 HOURS (WHICHEVER IS FIRST)	55
8.2.12	EVERY 5000 HOURS.....	55
8.2.13	GREASE HUBS PROCEDURE.....	55
8.2.14	GEARBOX/TRANSMISSION OIL & FILTER CHANGE PROCEDURES	55
8.2.14.1	PLANETARY GEARBOX.....	56
8.2.14.2	STOP & SHIFT GEARBOX (IF EQUIPPED).....	57
8.2.14.3	POWER SHIFT TRANSMISSION (IF EQUIPPED).....	58

TABLE OF CONTENTS

8.3	ADJUSTMENTS.....	59
8.3.1	SIDE DISCHARGE CONVEYOR.....	60
8.3.2	BELT CONVEYOR TENSION.....	60
8.3.3	TRACKING.....	61
8.3.4	FRONT DISCHARGE CONVEYOR - CHAIN.....	63
8.3.5	AUGER SCRAPER PLATE.....	63
8.3.6	AUGER TIMING.....	63
8.3.7	585 & 700 DRIVELINE ALIGNMENT.....	64
8.3.8	PTO CUTOUT CLUTCH CONNECTION.....	65
8.3.9	KNIVES.....	65
8.3.9.1	KNIFE REMOVAL.....	65
8.3.9.2	ADDING KNIVES.....	65
8.3.9.3	KNIFE PLACEMENT.....	65
8.3.9.4	KNIFE POSITION.....	66
8.3.9.5	REPLACING DAMAGED OR WORN KNIVES.....	66
8.3.10	BRAKE ADJUSTMENT (IF EQUIPPED).....	66
8.3.11	WHEEL BEARING PRELOAD.....	66
8.4	FASTENER TORQUE SPECIFICATIONS.....	67
8.4.1	GENERAL TORQUE SPECIFICATIONS.....	67
8.4.2	WHEEL TORQUE.....	69
8.4.3	HUB TORQUE.....	69
8.5	ELECTRICAL.....	70
8.5.1	POWER SHIFT REMOTE CONTROL PROGRAMMING.....	70
8.5.1.1	REMOTE TROUBLESHOOTING.....	71
8.5.2	DIGITAL SCALE INDICATOR.....	71
8.6	WHEELS AND TIRES.....	72
8.6.1	WHEEL INSTALLATION.....	72
8.6.2	TIRE INFLATION.....	72
8.6.3	IMPLEMENT TIRES.....	73
8.7	STORING THE IMPLEMENT.....	74
8.8	RETURN THE IMPLEMENT TO SERVICE.....	74
8.9	MIXER TROUBLESHOOTING GUIDE.....	75

TABLE OF CONTENTS

9.0 REPAIR PARTS	77
585 & 700 LIGHTS	78
F2-585 & F2-700 LIGHTS.....	79
WEIGH BAR WIRING DIAGRAM	80
585 & 700 ELECTRICAL SYSTEM	82
585 & 700 WIRING SCHEMATIC.....	82
F2 STOP & SHIFT ELECTRICAL SYSTEM.....	84
F2 POWER SHIFT ELECTRICAL SYSTEM.....	86
F2 STOP & SHIFT JUNCTION BOX	88
F2 POWER SHIFT JUNCTION BOX.....	89
SINGLE AXLE TRAILER	90
TANDEM AXLE TRAILER	92
TANDEM AXLE TRAILER (CONT'D)	94
585 & 700 PTO SHROUD	96
F2 PTO SHROUD.....	96
75-0209 HUB ASSEMBLY.....	98
75-0222 HUB ASSEMBLY.....	99
MIXER	100
FRONT FLAT & INCLINE BASE BELT CONVEYOR.....	102
FRONT FLAT & INCLINE BASE BELT CONVEYOR (CONT'D).....	104
FRONT FLAT & INCLINE BASE BELT CONVEYOR (CONT'D).....	106
FRONT FLAT BELT CONVEYOR HYDRAULIC SCHEMATIC	108
FRONT INCLINE BELT CONVEYOR.....	110
FRONT INCLINE BELT CONVEYOR (CONT'D).....	112
FRONT INCLINE BELT CONVEYOR (CONT'D).....	114
FRONT INCLINE BELT CONVEYOR (CONT'D).....	116
FRONT LH INCLINE BELT CONVEYOR HYDRAULIC SCHEMATIC	118
FRONT RH INCLINE BELT CONVEYOR HYDRAULIC SCHEMATIC.....	118
FRONT INCLINE BELT CONVEYOR STOP	120
FRONT FLAT & INCLINE CHAIN CONVEYOR ASSEMBLY	122
FRONT FLAT & INCLINE CHAIN CONVEYOR ASSEMBLY (CONT'D).....	124
FRONT FLAT & INCLINE CHAIN CONVEYOR ASSEMBLY (CONT'D).....	126
FRONT FLAT CONVEYOR	128
FRONT INCLINE CONVEYOR.....	128
FLAT CHAIN CONVEYOR HYDRAULIC SCHEMATIC	130
FRONT DISCHARGE INCLINE CHAIN CONVEYOR HYDRAULIC SCHEMATIC	132
FRONT DISCHARGE INCLINE CHAIN CONVEYOR HYDRAULIC SCHEMATIC	134

TABLE OF CONTENTS

SIDE DISCHARGE BELT CONVEYOR	136
SIDE DISCHARGE BELT CONVEYOR (CONT'D)	138
SIDE DISCHARGE BELT CONVEYOR (CONT'D)	140
SIDE DISCHARGE CHAIN CONVEYOR	142
SIDE DISCHARGE CHAIN CONVEYOR (CONT'D)	144
SIDE DISCHARGE INCLINE BELT & CHAIN CONVEYOR HYDRAULIC SCHEMATIC.....	146
DOOR	148
OPTIONAL REAR DOOR HYDRAULIC SCHEMATIC FOR FRONT DOOR & SIDE DOOR MOD- ELS	150
DOOR HYDRAULIC SCHEMATIC FRONT / LEFT / RIGHT / DUAL LEFT & RIGHT DOOR.	151
LADDER	152
VIEWING PLATFORM.....	154
AUGER	156
AUGER (CONT'D).....	158
585 & 700 STOP & SHIFT DRIVELINE	160
F2 DIRECT DRIVELINE	162
F2 STOP & SHIFT DRIVELINE	164
F2 POWER SHIFT DRIVELINE.....	166
585 & 700 STOP & SHIFT GEARBOX	168
585 & 700 STOP & SHIFT GEARBOX (CONT'D).....	170
F2 STOP & SHIFT GEARBOX	172
F2 STOP & SHIFT GEARBOX (CONT'D)	174
F2 POWER SHIFT TRANSMISSION	176
1800 SERIES PLANETARY	178
2100 SERIES PLANETARY	180
585 & 700 PLANETARY GEARBOX OIL SYSTEM.....	182
F2 PLANETARY GEARBOX OIL SYSTEM.....	184
STOP & SHIFT GEARBOX OIL SYSTEM.....	186
1-3/8-21 SPLINE X 1-3/4-20 SPLINE PTO DRIVE SHAFT	188
1-3/4-20 SPLINE X 1-3/4-20 SPLINE PTO DRIVE SHAFT (OPTIONAL)	190
1-3/8-21 SPLINE X 1-3/4-20 SPLINE CV PTO DRIVE SHAFT (OPTIONAL)	192
1-3/4-20 SPLINE X 1-3/4-20 SPLINE CV PTO DRIVE SHAFT (OPTIONAL)	194
1-3/4-20 SPLINE X 1-3/4-20 SPLINE PTO DRIVE SHAFT	196
1-3/4-20 SPLINE X 1-3/4-20 SPLINE PTO DRIVE SHAFT	198
1-3/4-20 SPLINE X 1-3/4-20 SPLINE 2500 SERIES DRIVELINE	200
DOUBLE UNIVERSAL JOINT W/CUTOUT CLUTCH	201
CUTOUT CLUTCH	202

TABLE OF CONTENTS

CUTOUT CLUTCH	203
1-3/4-20 SPLINE X 1-3/4-20 SPLINE DRIVESHAFT	204
10.0 OPTIONAL PARTS	205
HAY RETAINING RING	206
8" CAPACITY EXTENSION	207
TIP OFF FRONT INCLINE DISCHARGE (CHAIN ONLY) & SIDE DISCHARGE.....	208
SIDE DISCHARGE SLIDE TRAY	209
SLIDE TRAY HYDRAULIC SCHEMATIC	210
KICKER MAGNET	211
REMOTE SCALE MOUNT	212
RUBBER SIDE DOOR CHUTE ASSEMBLY	214
CONVEYOR HANGING MAGNET & WEIGHT ASSEMBLY	216
CONVEYOR DEFLECTOR ASSEMBLY	216
POWER MAGNET	218
11.0 SPECIFICATIONS.....	221
NOTES	226
12.0 MAINTENANCE RECORDS	227

5.0 SAFETY

The Meyer implement is manufactured with operator safety in mind. Located on the implement are various safety signs to aid in operation and warn of danger or caution areas. Pay close attention to all safety signs on the implement.

Carefully follow the operating and maintenance instructions in this manual and all applicable safety laws. Failure to follow all safety procedures may result in serious injury or death.

Before attempting to operate this implement, read and study the following safety information. In addition, make sure that every individual who operates or works with the implement, whether family member or employee, is familiar with these safety precautions.

Meyer Mfg. Corp. provides guards for exposed moving parts for the operator's protection; however, some areas cannot be guarded or shielded in order to assure proper operation. The operator's manual and safety signs on the implement itself warn you of dangers and must be read and observed closely!



Safety Alert Symbol

This symbol is used to call attention to instructions concerning personal safety. Be sure to observe and follow these instructions. Take time to be careful!



DANGER

The signal word **DANGER** on the machine and in the manual identifies a hazardous situation which, if not avoided, WILL result in death or serious injury.



WARNING

The signal word **WARNING** on the machine and in the manual indicates a potentially hazardous situation which, if not avoided, COULD result in serious injury or death.



CAUTION

The signal word **CAUTION** on the machine and in the manual indicates a potentially hazardous situation which, if not avoided, MAY result in minor or moderate injury. It may also be used to alert against unsafe practices.

IMPORTANT

This notice identifies procedures which must be followed to avoid damage to the machine.

Danger, Warning, Caution, and instructional decals and plates are placed on the equipment to protect anyone working on or around this machine, as well as the components of the machine. All personnel operating or maintaining this equipment must familiarize themselves with all Danger, Warning, Caution, and instructional decals and plates.

5.1 SAFETY PRECAUTIONS

 **CAUTION**



All individuals who will operate this implement must read and completely understand this Owner / Operator's and Parts Manual. Operator must receive instructions before operating the machine. Untrained operators can cause injury or death.

- DO NOT allow anyone to operate, service, inspect or otherwise handle this equipment until all operators have read and understood all of the instructional materials in this Operator's And Parts Manual and have been properly trained in its intended usage.
- For an operator to be qualified, he or she must not use drugs or alcohol which impair alertness or coordination while working. An operator who is taking prescription drugs must get medical advice to determine if he or she can safely operate a machine and the equipment.
- Make sure all personnel can READ and UNDERSTAND all safety signs.
- DO NOT allow minors (children) or inexperienced persons to operate this equipment.
- DO NOT operate until all shields and guards are in place and securely fastened.
- DO NOT step up on any part of the equipment that is not designated as a ladder or viewing platform at any time.
- DO NOT adjust, clean or lubricate while the equipment is in motion.
- Inspect when first delivered and regularly thereafter; that all connections and bolts are tight and secure before operating.
- Know how to stop operation of the equipment before starting it!
- Make certain everyone is clear of the equipment before applying power.
- Keep hands, feet and clothing away from moving parts. Loose or floppy clothing should not be worn by the operator.
- Observe all applicable traffic laws when transporting on public roadways (where legal to do so). Check local laws for all highway lighting and marking requirements.
- Shut off and lock out power before adjusting, servicing, maintaining or clearing an obstruction from this machine. Refer to 5.3 SHUTOFF & LOCKOUT POWER.
- Always enter curves or drive up or down hills at a low speed and at a gradual steering angle.
- Never allow riders on either tractor / truck or equipment.
- Keep tractor / truck in a lower gear at all times when traveling down steep grades.
- Stay away from overhead power lines. Electrocution can occur without direct contact.
- Use only properly rated undercarriage and tires.

Safety Precautions For Tractor Towed Units:

- Do not exceed 20 mph (32 kph). Reduce speed on rough roads and surfaces.
- Always install a SMV emblem on pull-type equipment when transporting on roadways and keep clean and bright.
- Always yield to oncoming traffic in all situations and move to the side of the road so any following traffic may pass.
- Comply with state and local laws governing highway safety and movement of machinery on roadways.

Safety Precautions For Hydraulic System:

- Check hydraulic tubes, hoses and fittings for damage and leakage. Never use hands to check for leaks. Hydraulic tubes and hoses must be properly routed and have adequate support and secure clamps. Tighten or replace any parts that show leakage.
- Always clean fluid spills. Do not use gasoline or diesel fuel for cleaning parts. Use commercial nonflammable solvents.

5.2 SAFETY SIGNS



Read all safety signs on the implement and in this manual. Keep all safety signs clean and replace any damaged or missing safety signs before operating the equipment. Do not remove any safety signs. Safety signs are for operator protection and information.

FRONT OF IMPLEMENT

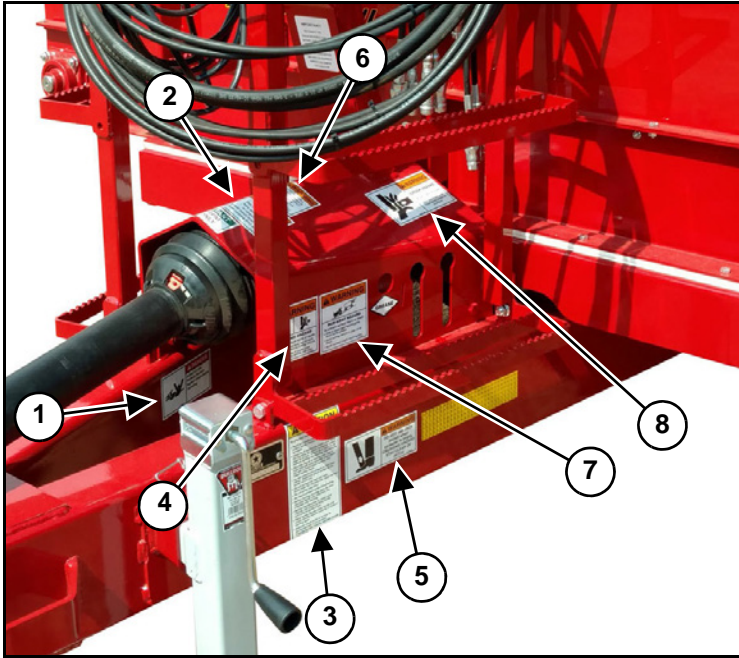

PART NO. 46-3600-2
(Located On Trailer Frame Underneath Housing)



PART NO. 46-3600-9

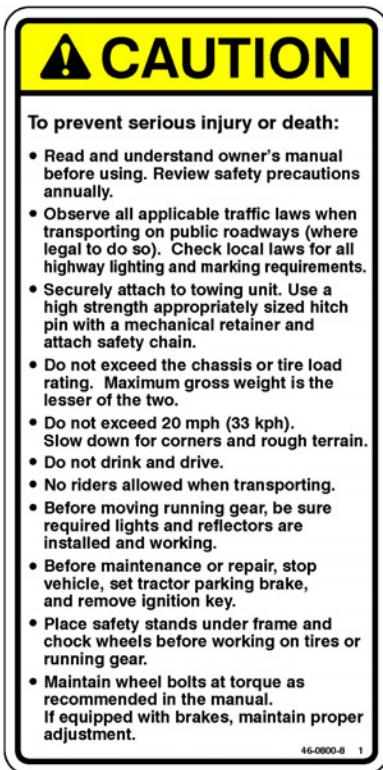

PART NO. 46-0800-8



PART NO. 46-0800-6



PART NO. 46-0800-7



PART NO. 46-3600-6



PART NO. 46-0004-2

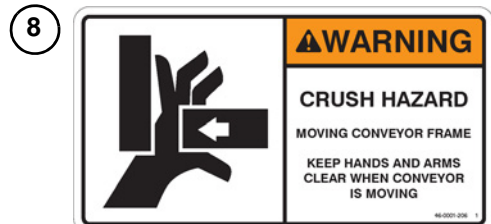

PART NO. 46-0001-206

FRONT OF IMPLEMENT

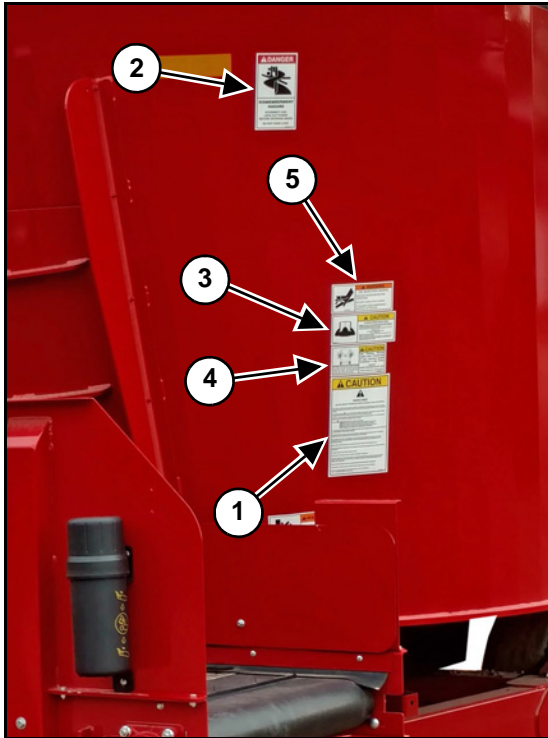

1

⚠ CAUTION



SAFETY FIRST

Do Not Operate This Machine Without Reading These Instructions!

Meyer Manufacturing Corporation provides guards for exposed moving parts for the operator's protection; however, some areas cannot be guarded or shielded in order to ensure proper operation. The operator's manual and safety signs on the equipment itself warn you of hazards and must be read and observed closely!

The safety alert symbol  is used to call attention to instructions concerning personal safety. Be sure to observe and follow these instructions. Take time to be careful!

⚠ SAFETY PRECAUTIONS

DO NOT allow anyone to operate, service, inspect or otherwise handle this equipment until all operators have read and understood all of the instructional materials in the operator's and parts manual and have been properly trained in its intended usage.

DO NOT operate until all shields and guards are in place and securely fastened.

DO NOT step up on any part of the equipment that is not designated as a seat, ladder, or viewing platform at any time. Never allow riders on either tractor / truck or equipment.

Ensure the machine is and will remain in the OFF condition before adjusting, servicing, maintaining, or clearing an obstruction from this machine.

PTO OPTIONS: The tractor PTO **MUST** match the implement PTO. **NEVER USE PTO ADAPTERS.** PTO shield **MUST** be in place and rotate freely. Always run PTO in a straight line to avoid an accident due to PTO damage.

Know how to stop operation of the equipment before starting it! Make certain everyone is clear of the equipment before applying power. Make certain everyone stays clear of the discharge opening while operating.

Keep hands, feet, and clothing away from moving parts. Loose or floppy clothing should not be worn by the operator.

Observe all applicable traffic laws when transporting on public roadways (where legal to do so). Check local laws for all highway lighting and marking requirements.

Keep all safety signs clean and replace any damaged or missing safety signs before operating the equipment. **DO NOT** remove any safety signs. If any safety signs become damaged or lost, call your local Meyer dealer or Meyer factory direct 1-800-325-9103 for replacement. Always use **GENUINE MEYER** replacement parts.

46-0001-22 1

PART NO. 46-0001-22

2

⚠ DANGER



DISMEMBERMENT HAZARD

DISCONNECT AND LOCK OUT POWER BEFORE ENTERING MIXER

DO NOT HAND LOAD

46-0001-213 1

PART NO. 46-0001-213

3

⚠ CAUTION

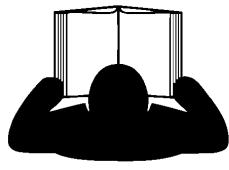

TO PREVENT SERIOUS INJURY OR DEATH

- **DO NOT** start, operate, or work on this machine without first carefully reading and thoroughly understanding the entire contents of the operators manual. (Require the same of all personnel who will operate this machine.)
- If operators manual is lost, contact your nearest Meyer Dealership or write or call:

MEYER MFG., CORP.
P.O. BOX 405 • Dorchester, WI 54425-0405
Phone 1-800-325-9103

 Please give your name, address, phone number, model and serial number of your machine. A manual will be furnished.
- If you have any questions about operation or adjustments, and maintenance of this machine, contact your Meyer Dealership or Meyer Mfg., Corp. before starting or continuing the operation of this machine.

46-0001-35 1

PART NO. 46-0001-35

4

⚠ CAUTION

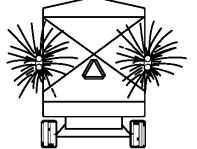

Use Flashing Warning Lights when transporting on **ALL** highways (public roadways) at **ALL** times.

EXCEPT WHEN PROHIBITED BY LAW!
(Check w/local law enforcement)

46-0001-62 1

By all State and Federal laws, implement lights do not replace the SMV (Slow-Moving Vehicle) Identification Emblem. All towed agricultural vehicles must display SMV Emblems when traveling LESS than 20 mph (32 kph).

PART NO. 46-0001-62

5

⚠ WARNING



OIL INJECTION HAZARD

RELIEVE PRESSURE BEFORE SERVICING.

DO NOT CHECK WITH HANDS.

IF INJURED SEEK EMERGENCY MEDICAL ATTENTION.

46-8500-7 1

PART NO. 46-8500-7

FRONT OF IMPLEMENT

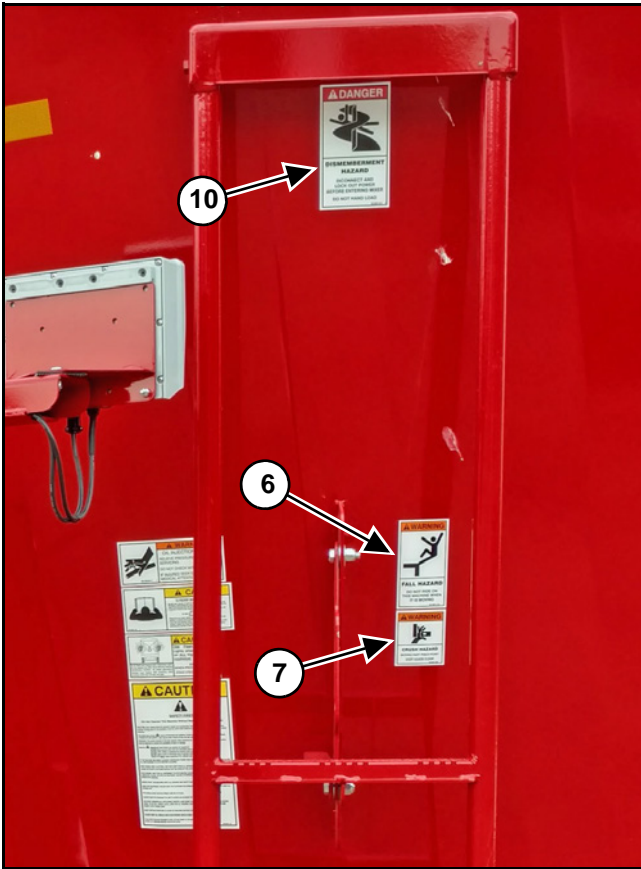

PART NO. 46-0001-210

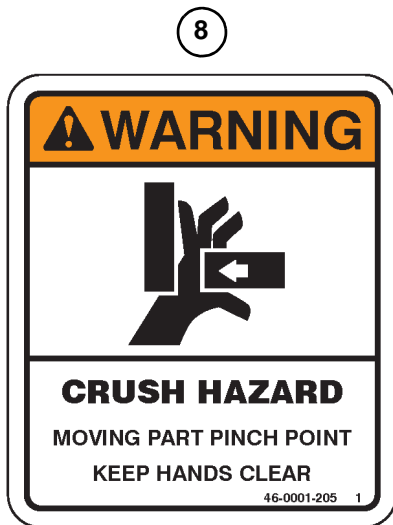

PART NO. 46-0001-205



PART NO. 46-0001-213

LEFT SIDE OF IMPLEMENT



PART NO. 46-0001-211
(Located Under Mixing Tub)



PART NO. 46-0001-212
(Behind Belting - Not Shown)



PART NO. 46-0001-206
(Both Sides On Some Models)



PART NO. 46-8500-7

RIGHT SIDE OF IMPLEMENT

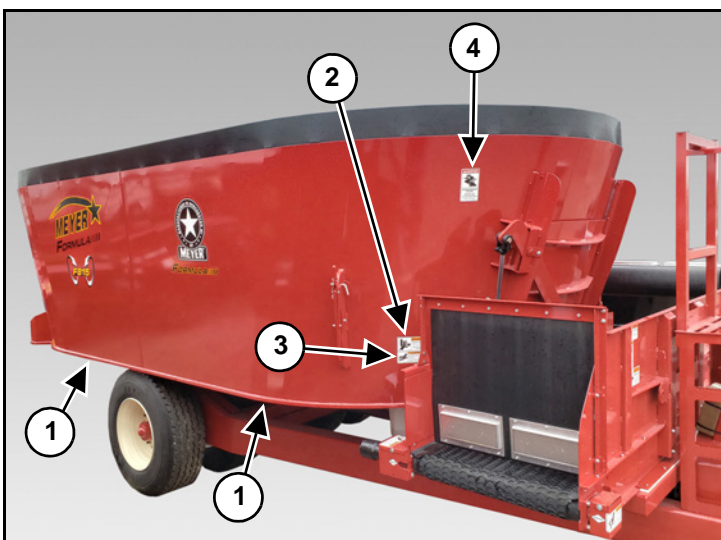

PART NO. 46-0001-213

LEFT SIDE OF IMPLEMENT

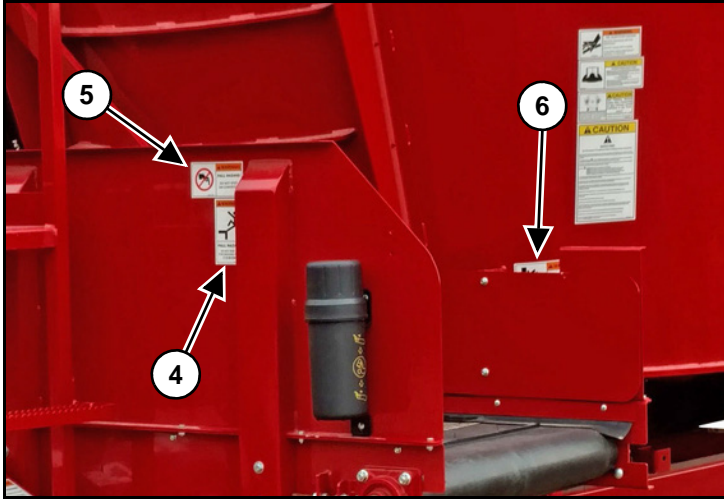

PART NO. 46-0001-4
(Located On Top Of Shield - Not Shown)

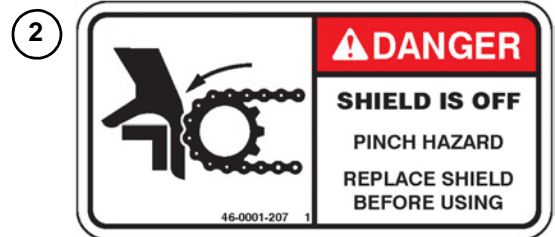

PART NO. 46-0001-207
(Located Under Shield - Not Shown)

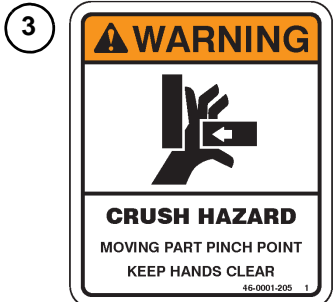

PART NO. 46-0001-205



PART NO. 46-0001-210



PART NO. 46-0001-209

RIGHT SIDE OF IMPLEMENT

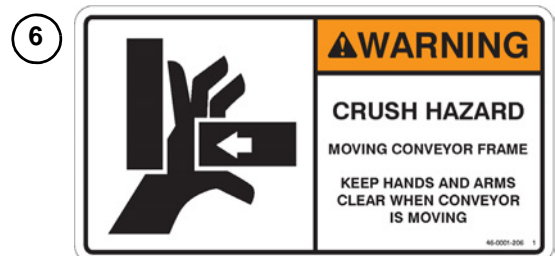
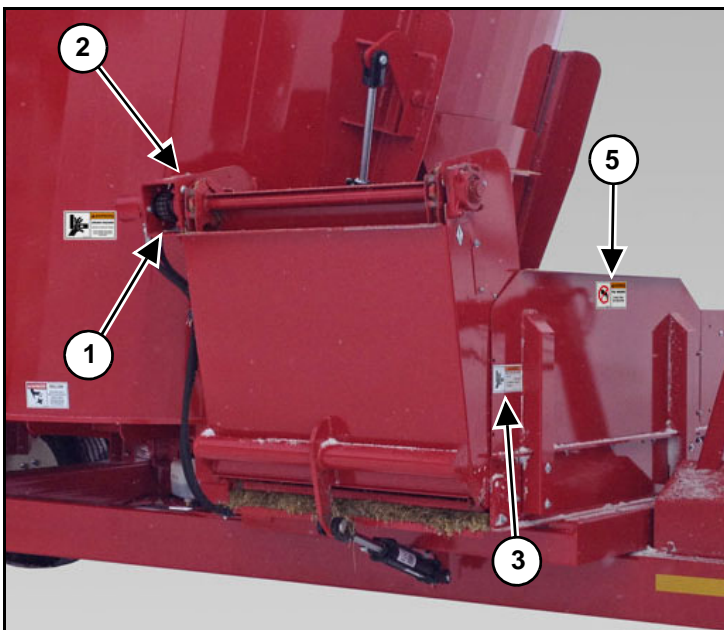

PART NO. 46-0001-206
(Both Sides On Some Models)

BACK OF IMPLEMENT

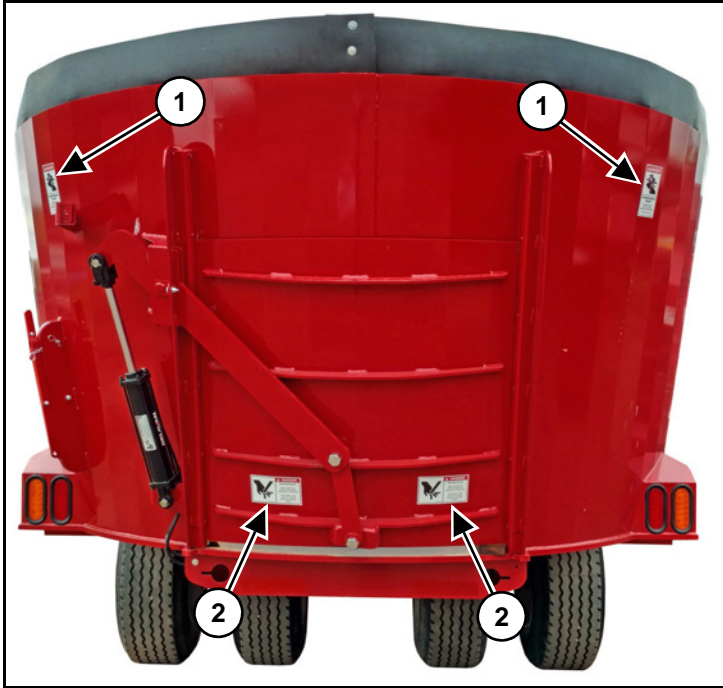

PART NO. 46-0001-213

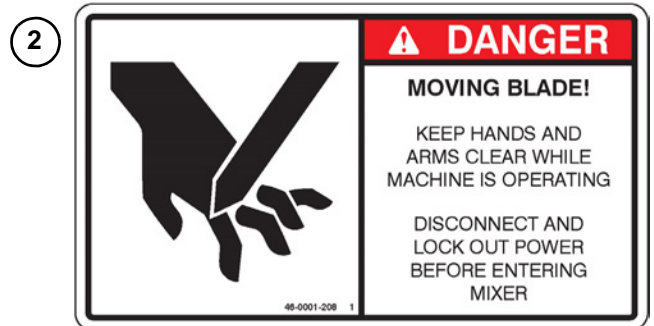

PART NO. 46-0001-208

SIDE DOOR CONVEYOR (OPTION)

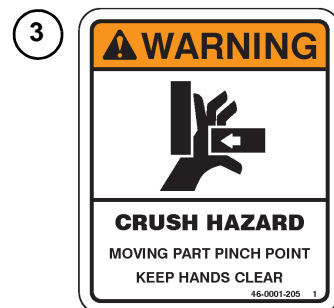
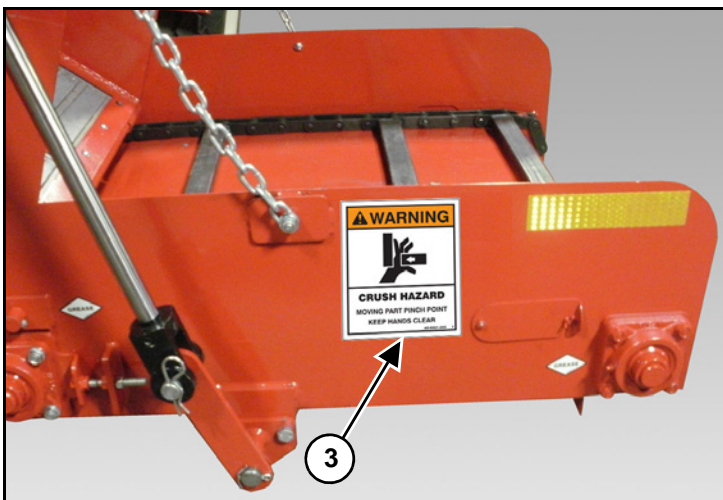

PART NO. 46-0001-205

5.3 SHUTOFF & LOCKOUT POWER



CAUTION

Any individual that will be adjusting, servicing, maintaining, or clearing an obstruction from this machine needs to ensure that this machine stays safely OFF until the adjustment, service, or maintenance has been completed, or when the obstruction has been cleared, and that all guards, shields, and covers have been restored to their original position. The safety of all individuals working on or around this machine, including family members, are affected. The following procedure will be referred to throughout this manual, so be familiar with the following steps.

5.3.1 Shutoff & Lockout Power Recommendations

1. Think, Plan and Check

- a. **THINK** through the entire procedure and identify all the steps that are required.
- b. **PLAN** what personnel will be involved, what needs to be shut down, what guards/shields need to be removed, and how the equipment will be restarted.
- c. **CHECK** the machine over to verify all power sources and stored energy have been identified including engines, hydraulic and pneumatic systems, springs and accumulators, and suspended loads.

2. Communicate - Let everyone involved, including those working on or around this machine, that work is being done which involves keeping this machine safely “OFF”.

3. Power Sources

- a. **LOCKOUT** - Shut off engines and take the key, or physically lock the start/on switch or control. Disconnect any power sources which are meant to be disconnected (i.e. electrical, hydraulic, and PTO of pull-type units).
- b. **TAGOUT** - Place a tag on the machine noting the reason for the power source being tagged out and what work is being done. This is particularly important if the power source is not within your sight and/or will need to be isolated for a longer period of time.

4. Stored Energy - Neutralize all stored energy from its power source. Ensure that this machine is level, set the parking brake, and chock the wheels. Disconnect electricity, block movable parts, release or block spring energy, release pressure from hydraulic and pneumatic lines, and lower suspended parts to a resting position.

5. Test - Do a complete test and personally double check all of the above steps to verify that all of the power sources are actually disconnected and locked out.

6. Restore Power - When the work has been completed, follow the same basic procedures, ensuring that all individuals working on or around this machine are safely clear of the machine before locks and tags are removed and power is restored.

IMPORTANT

It is important that everyone who works on this equipment is properly trained to help ensure that they are familiar with this procedure and that they follow the steps outlined above.

This manual will remind you when to SHUTOFF & LOCKOUT POWER.

6.0 PRE-OPERATION



Always keep all shields and guards in place and securely fastened. Keep hands, feet and clothing away from moving components.



DO NOT allow anyone to operate, service, inspect or otherwise handle this implement until all operators have read and understand all of the instructional materials in this Owner / Operator's and Parts Manual and have been properly trained in its intended usage.

Verify that the implement is securely hitched to the tractor/truck.

Verify that all electrical/hydraulic connections and bolts/hardware are tight and securely fastened before operating the implement.

Wear safety glasses to prevent eye injury when any of the following conditions exist:

- When fluids are under pressure.
- Flying debris or loose material is present.
- Tools are being used.

6.1 STATIC INSPECTION



Hydraulic fluid escaping under pressure can have sufficient force to cause injury. Keep all hoses and connections in good serviceable condition.

Before operating the mixer for the first time and each time thereafter, check the following items:

1. Check that all safety signs are in good and legible condition.
2. Inspect the mixer for proper adjustments. Refer to Section 8.3 ADJUSTMENTS.
3. Check that all lubrication has been completed. Refer to Section 8.2 LUBRICATION.
4. Make sure that all guards and shields are in place, secured and functioning as designed.
5. Check condition of all hydraulic components for leaks and electrical cords and cables for wear. Repair or replace as required.
6. Check the planetary gearbox and stop & shift gearbox reservoir (If Equipped) for proper oil level. Check power shift transmission sight glass (If Equipped) for proper oil level. Refer to Section 8.2 LUBRICATION.
7. Check for and remove any foreign objects in the mixing chamber and discharge opening.
8. Be sure that there are no tools laying on or in the mixer.
9. Verify that all electrical and hydraulic connections are tight and secure before operating.
10. Check that all hardware is in place and is tight.
11. Watch for any worn or cracked welds. If found, have qualified personnel repair immediately or replacement is necessary.
12. Check all bearings. Replace as needed.
13. Inspect any wear items. i.e.: Knives, scrapers, kicker wear plate. Replace as required.
14. Inspect the tires for excessive wear or damage and inflate to the recommended pressure. Refer to Section 8.6 WHEELS AND TIRES.
15. Inspect the condition of axles, o-beams, spindles, and safety lighting. Repair or replace as required.

6.2 LIGHT HOOK-UP

Note: *The lighting system provided is intended for being transported by an agricultural tractor.*

Ensure that lights and indicators are clean and in good working order. When attaching to a towing vehicle other than a tractor always check lighting for proper operation as wiring may vary. Connect to the standardized 7-pin socket located at the back of the tractor.

Models	Color	Function	SAE Terminal	SAE Connector
All Models	White	Ground	1	 <p>Viewed From Back</p>
F2 Models	White	J-Box Ground	1	
All Models		Not Used	2	
All Models	Yellow	Left Turn & Hazard	3	
All Models		Not Used	4	
All Models	Green	Right Turn & Hazard	5	
All Models	Brown	Tail Lights	6	
F2 Models	Black	J-Box	7	

Note: *The brake wire should only be connected to the #4 terminal if the #4 terminal on the tractor is confirmed to be a brake light terminal. If the tractor does not have a brake light terminal, cap / seal off the end of the brake wire of the implement (secure to other wires).*

6.3 HYDRAULIC HOOK-UP



Hydraulic fluid escaping under pressure can have sufficient force to cause injury. Keep all hoses and connections in good serviceable condition.

Whenever working on any part of the hydraulics, safely relieve hydraulic pressure before starting.



Do not exceed maximum PSI or a motor failure could result.

Pull Type: Requires 25 GPM @ 3000 PSI.

Call the factory if additional information is needed.

Note: *The PTO horsepower and/or hydraulic requirements may not reflect adequate tractor size for towing the machine.*

6.4 PTO DRIVELINE OPTION



Do not operate without PTO guard on implement and tractor. Maintain PTO drive shaft guard in good operating condition. Replace them if damaged and not turning freely.

CAUTION

Shutoff and lockout power before adjusting, servicing, maintaining, or clearing an obstruction from this machine. Refer to section 5.3 SHUTOFF & LOCKOUT POWER.

The tractor half of the PTO drive shaft assembly must be locked securely to the tractor output shaft and the implement half of the PTO drive shaft assembly must be locked securely to the implement driveline.

See the PTO Installation, Service, and Safety Instruction Manual for additional PTO details. For a replacement manual, call the factory at 1-800-325-9103.

See the ADMA Safety Manual for further safety situations and precautions, ensure all operators become familiar with it. For a replacement manual, call the factory at 1-800-325-9103.

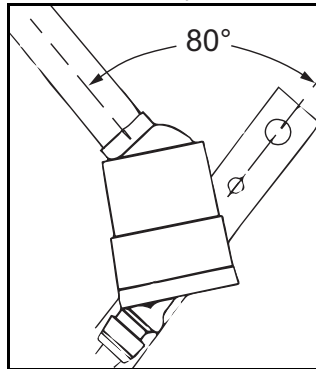

IMPORTANT

Do not exceed the maximum 80° turning angle on the constant velocity PTO driveline. Exceeding the turning angle will damage the constant velocity “center housing” and exerts excessive pressures on the PTO input center shaft and related bearings.

6.5 TRACTOR DRAWBAR SETUP

Do not operate 1000 RPM implements at 540 RPM. No PTO adapter should be used to alter speed or geometry.

Set the tractor drawbar to conform to the standard dimensions as shown. An improperly located hitch point may cause damage to the universal joints of the PTO drive shaft. This will ensure that the PTO drive shaft will not be over extended.

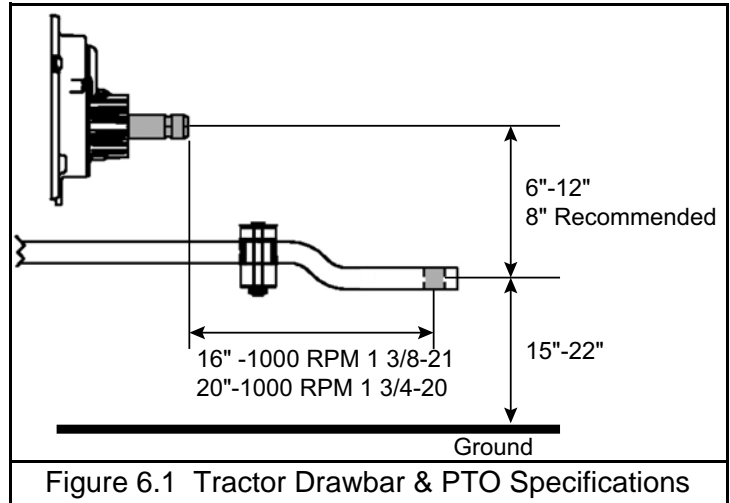

An improperly positioned hitch point may cause damage to the universal joints of the PTO drive shaft. Conforming to the standard 16" or 20" drawbar & PTO relationship will ensure that the PTO drive shaft will not become over-extended.

With initial hook-up to your implement test PTO travel by turning equipment in both directions observing the minimum (A) and maximum (B) travel dimensions.

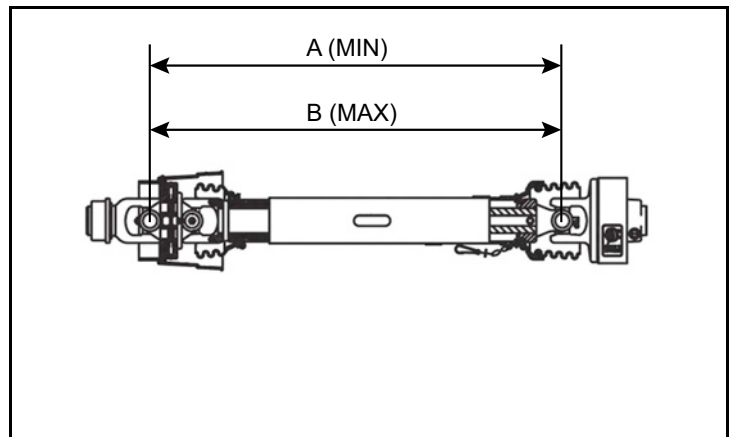

PTO PART NUMBER	A	B
118-VM-0026-55	38.39"	51.18"
118-VM-0025-55	33.27"	46.06"
118-VM-0023-55	38.19"	50.98"
118-VM-0024-55	38.19"	50.98"

6.6 HITCHING TO TRACTOR



Do not allow anyone to stand between the tongue or hitch and the tractor when backing up to the implement.

Before hitching to the tractor, make sure that there is sufficient ballast on the front axle of the tractor.

Depending on conditions, the ballast weight needs to be adjusted to optimize tractor drive. The front axle load must never, under any circumstances, be less than 20% of the tractor's unladen weight.

Move to the operator's position, start the engine and release the parking brake.

Move the tractor in front of the mixer. Slowly move the tractor backwards towards the mixer and align the drawbar with the implement's hitch.

Note: *Lower or raise the mixer jack to properly align the drawbar and hitch.*

Fasten the forage box hitch to the tractor drawbar with a properly sized hitch pin with safety retainer. (Reference ANSI/ASABE AD6489-3 Agricultural vehicles - Mechanical connections between towed and towing vehicles - Part 3: Tractor drawbar.) (See your Trailer / Chassis manual for further details.)

Before operation and after hitching the tractor to the implement, connect the hydraulic hoses and light cord to the tractor. Connect any optional equipment as needed.

6.6.1 Jack Storage

After hitching the mixer or the tractor.

Using the handle, raise the jack off the ground and remove the pin. Move the jack to the storage mount (Item 1) located on the back left hand side of the mixing tub. Reinstall the pin to lock the jack into the transport position.

Note: *Keeping jack stored in proper position will keep it from getting damaged during transportation.*



Figure 6.2 Jack Storage

6.7 START-UP AND SHUT-DOWN

WARNING

Disengage electric/ hydraulic power, engage the machine's parking brake, stop the engine and make sure all moving components are completely stopped before connecting, disconnecting, adjusting or cleaning this equipment.

Always keep all shields and guards in place and securely fastened.

Keep hands, feet and clothing away from moving components.

CAUTION

Shutoff and lockout power before adjusting, servicing, maintaining, or clearing an obstruction from this machine. Refer to section 5.3 SHUTOFF & LOCKOUT POWER.

DO NOT allow anyone to operate, service, inspect or otherwise handle this implement until all operators have read and understand all of the instructional materials in this Owner / Operator's and Parts Manual and have been properly trained in its intended usage.

Before operating the implement, look in all directions to ensure there are no bystanders, especially small children, in the work area.

6.7.1 Start-Up

1. Be sure there is no one inside the mixer and the mixer is empty.
2. Enter the tractor and start the engine.
3. Set the parking brake.
4. Check to see that the discharge door is closed.
5. Slowly engage the PTO and operate at idle speed.
6. Bring PTO RPM up to the implement's rated RPM.

6.7.2 Shut-Down

1. Disengage the PTO.
2. Turn off conveyor, if equipped.
3. Fully lower all doors.
4. Raise slide trays or conveyors, if equipped.
5. Park the mixer on a flat, level surface.
6. Engage the parking brake, stop the engine and exit the tractor.

6.8 OPERATIONAL CHECKS



Always keep all shields and guards in place and securely fastened. Keep hands, feet and clothing away from moving components.



Shutoff and lockout power before adjusting, servicing, maintaining, or clearing an obstruction from this machine. Refer to section 5.3 SHUTOFF & LOCKOUT POWER.

DO NOT allow anyone to operate, service, inspect or otherwise handle this implement until all operators have read and understand all of the instructional materials in this Owner / Operator's and Parts Manual and have been properly trained in its intended usage.

Before operating the implement, look in all directions to ensure there are no bystanders, especially small children, in the work area.



Once PTO has been disengaged and a change of auger speed has been selected, allow at least 5 seconds for the stop & shift gearbox to complete the shift process before engaging PTO.

Before running material through the mixer for the first time and each time thereafter, follow these steps:

1. Follow the Start-Up procedure section 6.7.1 Start-Up.
2. Raise and lower the door several times.
3. Lower and raise mixer slide trays or conveyors, if equipped.
4. Operate the mixer augers and conveyors, if equipped, for approximately 5-10 minutes. If mixer is equipped with a stop & shift gearbox or power shift transmission:

Stop & Shift Gearbox: Stop the tractor PTO. Once the PTO has completely stopped, shift the stop & shift gearbox to high. Wait 5 seconds. Engage the tractor PTO and bring RPM back up to operating speed for the last minute of test run time.

Power Shift Transmission: Shift the power shift transmission into high for the last minute of test run time.

5. Follow the Shut-Down procedure section 6.7.2 Shut-Down.
6. Check drive components to be sure components are not abnormally hot.
7. Check all hydraulic components for leaks.
8. Adjust and lubricate equipment as needed. See Section 8.3 ADJUSTMENTS and Section 8.2 LUBRICATION.

6.8.1 Controls

6.8.1.1 Stop & Shift Gearbox

IMPORTANT

Once PTO has been disengaged and a change of auger speed has been selected, allow at least 5 seconds for the stop & shift gearbox to complete the shift process before engaging PTO.

A control box is provided with the mixer. There is a single 2-position switch, one position to shift to “Low” (Item 1) and one to shift to “High” (Item 2). Mixers equipped with a stop & shift gearbox will automatically begin the shift process after selecting a different speed and the PTO has stopped to prevent damage to the gearbox. Once PTO has been disengaged and a change of auger speed has been selected, allow at least 5 seconds before engaging PTO.

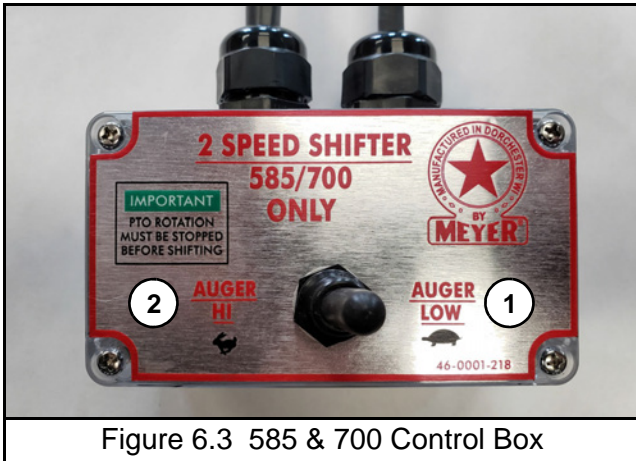

Figure 6.3 585 & 700 Control Box

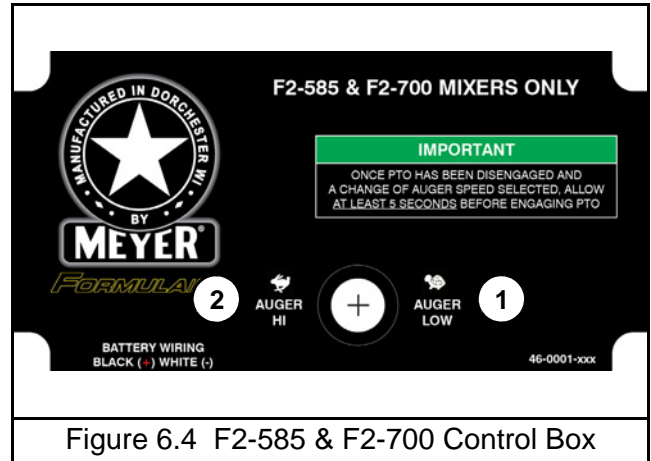

Figure 6.4 F2-585 & F2-700 Control Box

6.8.1.2 Power Shift Transmission

A remote control is provided with the mixer. There are 2 switches, one to shift to “Low” (Key 1) and one to shift to “High” (Key 2). The power shift transmission will only shift to “High”, once selected, if the PTO RPM is at 650RPM. The “High” speed light (Key 3) will light up indicating the power shift transmission is in “High” speed.



Figure 6.5 Remote



Figure 6.6 “High” Speed Indicator Light

6.9 TRANSPORTING

CAUTION

- DO NOT allow anyone to operate, service, inspect or otherwise handle this implement until all operators have read and understand all of the instructional materials in this Owner/ Operator's and Parts Manual and have been properly trained in its intended usage.
 - Before operating the implement, look in all directions to ensure there are no bystanders, especially small children, in the work area.
 - No riders allowed when transporting.
 - Do not drink and drive.
 - Before moving, be sure required lights and reflectors are installed and working.
 - Before maintenance or repair, stop vehicle, set parking brake, and remove ignition key.
 - Place safety stands under frame and chock wheels before working on tires or chassis.
 - Maintain wheel bolts at torque as recommended in the manual.
 - If equipped with brakes, maintain proper adjustment.
-

CAUTION

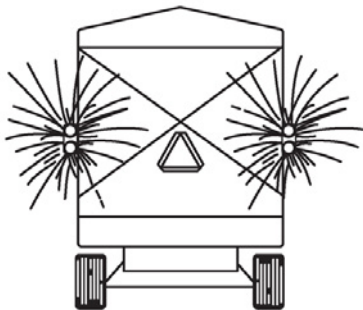

PULL-TYPE UNITS

- Use flashing warning lights when transporting on ALL highways (public roadways) at ALL times (Tractor towed models) EXCEPT WHEN PROHIBITED BY LAW! (Check w/local law enforcement).
 - Adhere to all state and federal laws. Implement lights do not replace the SMV (Slow-Moving Vehicle) identification emblem. All towed agricultural vehicles must display SMV emblems when traveling LESS than 20 mph (32 kph).
 - Check for traffic constantly. Be sure you can see that no one is attempting to pass you and that all traffic is sufficiently clear from you before making any turns.
 - Securely attach to towing unit. Use a high strength appropriately sized hitch pin with mechanical retainer and attach safety chain.
 - Do not exceed 20 mph (32 kph). Slow down for corners and rough terrain.
-

WARNING



- Shift to lower gear before going down steep grades
 - Avoid traveling on slopes or hills that are unsafe
 - Keep towing vehicle in gear at all times
 - Never exceed a safe travel speed (may be less than 20 MPH)
-

WARNING

You must observe all applicable traffic laws when transporting on public roadways. Check local laws for all highway lighting and marking requirements.

(Tractor Powered) Do not tow at speeds in excess of 20 mph.

IMPORTANT

Verify that the rear discharge door is in the closed position before traveling on roadways.

If you will travel on public roads and it is legal to do so, you must know all rules governing such operation. This will include lighting and brake requirements in addition to traffic rules.

Note: *An optional highway lighting package is available to assist in meeting these requirements. See your Meyer dealer for details.*

6.9.1 Safety Chain

The chain must be of adequate size to hold the weight of the loaded implement.

Note: *If using a grab hook at the end(s) of the chain to secure the chain to itself, a hook latch (Item 1) must be installed.*

The length of the safety chain is not to be any longer than necessary to turn without interference. If any chain links or attachment hardware are broken or stretched, repair before using. Store chain so it does not corrode or become damaged. Do not use this chain for other implements because the strength and length of the chain may not be adequate. Identify this chain for use on this particular implement.

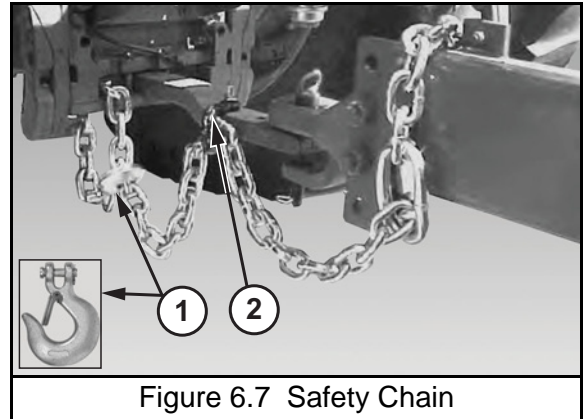

Figure 6.7 Safety Chain

Note: *Do not use the intermediate support (Item 2) as the attaching point.*

IMPORTANT

If you do not have a safety chain, or a replacement safety chain is needed, see your local Meyer dealer and do not operate on public roads until you are able to travel with the safety chain properly installed.

6.9.2 Tractor Towing Size Requirements

Use the following charts to help calculate the minimum tractor weight when towing without implement brakes. The minimum tractor weight, up to 20 mph (33 kph) needs to be two thirds of the box Gross Weight (GW). Gross Weight is calculated by the empty weight of the box and undercarriage combined added to the Load Weight. Then take the Gross Weight and multiply it by 0.667 and you will get the Minimum Required Weight of the Tractor. A tractor with this recommended weight for your machine is normally adequate for towing the loaded machine under average conditions.

Note: *Implement Loaded Weight x 0.667 = Minimum Tractor Weight Up to 20 mph*

Model	MAXIMUM IMPLEMENT GROSS WEIGHT (LBS)	MINIMUM TRACTOR WEIGHT UP TO 20 MPH (LBS)

6.10 DIGITAL SCALE INDICATOR

Refer to scale indicator (Item 1) manufacturer’s operators manual for operation.

See 8.5.2 Digital Scale Indicator for additional scale maintenance information.

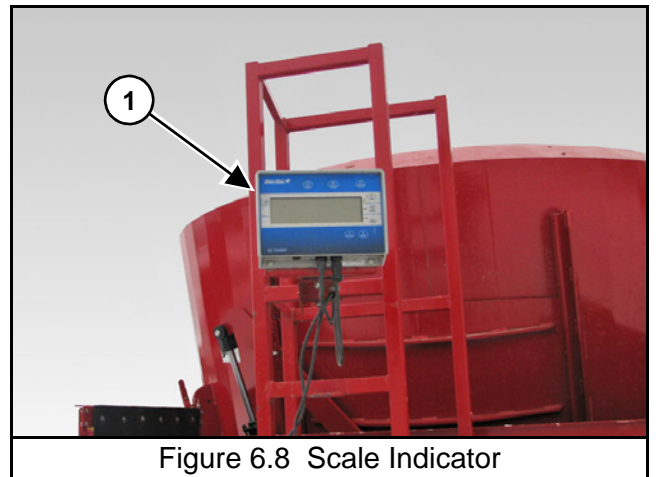
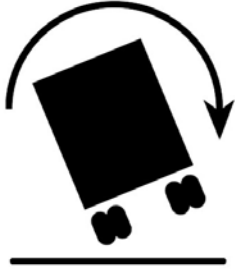

Figure 6.8 Scale Indicator



7.0 OPERATION

CAUTION



- **DO NOT** allow anyone to operate, service, inspect or otherwise handle this implement until all operators have read and understand all of the instructional materials in this Owner/ Operator's and Parts Manual and have been properly trained in its intended usage.
- **Before operating the implement, look in all directions to ensure there are no bystanders, especially small children, in the work area.**
- **Do not climb or step on any part of the implement at any time.**
- **Turn on level ground. Slow down when turning.**
- **Go up and down slopes, not across them.**
- **Keep the heavy end of the machine uphill.**
- **Do not overload the machine.**
- **Check for adequate traction.**

7.1 GENERAL

IMPORTANT

Always operate at the rated PTO speed but **DO NOT EXCEED THE RATED PTO SPEED**. If the mixer is operated faster than the rated PTO speed the strain on the drive train and mixer is greatly increased.

Do not force hay into the auger with loader or any other device.

Be aware of the overall size of the mixer to allow clearance through doorways.

The mixer is designed for blending dairy and beef rations. The mixer performance can vary according to the difference in material, loading sequence, mixing speed and unloading methods. The following guidelines should be understood before operating the mixer.

A new mixer will need an initial run-in period to polish the augers and mixer sides to achieve correct material movement inside the mixer. Until the unit is polished inside the user may experience material spillage, dead spots, or increased horsepower requirements. The load size may need to be reduced until the unit is polished inside.

7.1.1 Material



WARNING

Never hand feed material into mixer while it is running. Augers may cut or grab hands, clothing or material being loaded. Always stop the tractor's engine before hand loading materials.

Some feed materials will need to be processed alone in the mixer before they can be efficiently mixed with other feed materials.

- Large square or round bales of alfalfa
- Large square or round bales of high moisture content
- Large square or round bales of long mixed grasses, wheat or oat hay
- Large square or round bales of crop residue such as straw or soybean stubble
- Very light and bulky feed material

NOTE: Always remove any twine, net or plastic wrap from bales before loading into mixer.

7.1.2 Cutout Clutch

The clutch is designed to limit the amount of torque transferred to the machine through the driveline. If excessive torque is developed the clutch will disengage. A loud ratcheting sound will be heard and the transfer of power to the machine will be disrupted. This may occur when mixing or unloading a heavy mix or if an obstruction has lodged within the mixer. This is to protect the driveline from damage. To re-engage the machine, simply shut down the PTO and allow the driveline to come to a stop. The PTO can then be re-engaged to restart the mixer. The cutout clutch will either re-engage upon shut down of the PTO or just before it comes to a complete stop.

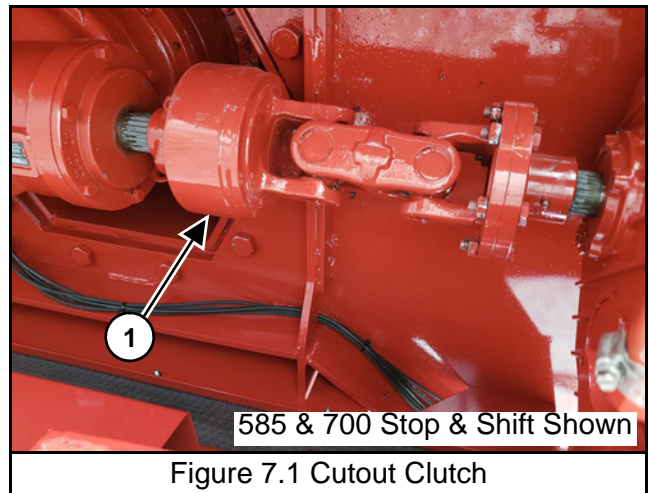

Figure 7.1 Cutout Clutch

7.2 LOADING



DO NOT ENTER MIXING CHAMBER WHILE MIXER IS RUNNING! Shutoff and lockout power before attempting to clear an obstruction or to perform work inside the mixing chamber. Refer to section 5.3 SHUTOFF & LOCKOUT POWER.



Be aware of power lines and other overhead obstructions when loading with a telescopic arm or loader.



Shutoff and lockout power before adjusting, servicing, maintaining, or clearing an obstruction from this machine. Refer to section 5.3 SHUTOFF & LOCKOUT POWER.

Comply with the safety instructions stipulated in the User Manuals for the operation / handling equipment used for loading the mixer.

Do not climb or step onto the platform or ladder before the parking brake has been applied.

When loading from a raised bay or platform, adopt the necessary measures (safety rails, etc.) to avoid people or equipment from falling into the machine.



Overloading may cause failure of axles, tires, structural members, hitches, loss of vehicle control. **DO NOT** exceed maximum gross weight.

NOTE: *Overloading can have detrimental effects on the integrity of the implement and it's safe use. Overloading will void warranty and increase risk to the operator's safety. Always be aware of your gross weight.*

Before loading, especially in freezing weather, make sure the augers are free to rotate and the discharge door moves freely up and down.

MATERIAL	LBS / CU.FT.
Soybeans	47 lbs.
Cotton Seed (Dry)	20 lbs.
Corn (Shelled)	45 lbs.
Corn Silage	30 lbs.
Haylage	20 lbs.
Sawdust	17 lbs.

NOTE: *Maximum Gross Weight is the lesser value between the implement or tires.*

MODEL	MAXIMUM MIXER GROSS WEIGHT	TOTAL NET WEIGHT (LBS)	CU. FT. CAPACITY**

** Struck capacity, heaped loads significantly increase weight.

When loading material into the mixer with an end-loader, dump the material into the center of the mixer.

1. Be sure that mixer is parked on a level surface.
2. The tractor should be straight in line with the mixer.
3. Completely close the mixer discharge door(s).
4. Set hay stops according to the instructions in this manual. See section 7.8 HAY STOP ADJUSTMENT.
5. Enter the tractor and start the engine.
6. Engage the PTO / hydraulics.
7. Set the tractor engine to operate at approximately 3/4 of rated PTO speed.
8. Load baled hay into the center of the mixer.
9. Allow mixer enough time to process the bale before adding other ingredients (4-10 minutes).

NOTES:

- ***Processing of long stem forages will continue as other materials are added and mixed. Be careful not to over process these materials before adding other ingredients.***
- ***Mixers equipped with a stop & shift gearbox or power shift transmission can process roughages in “Low” or “High” depending on how fast the bale needs to be processed. Mix all other materials in “Low”.***

7.2.1 Loading Sequence

IMPORTANT

Load all ingredients as quickly as possible. Allow a final mix time of 3-7 minutes, or whenever the load looks consistently mixed.

Never load long stem bales last. They will not be processed or mixed into the ration and may cause unloading difficulties or spillage.

NOTE: The loading sequence could vary.

The following is an example of a typical loading sequence:

1. Load and process long stemmed materials.
2. Load haylage and corn silage.
3. Load minerals, proteins and other small quantity ingredients.
4. Load grains, wet and dry commodities, etc.
5. Load all liquid fats, water and other liquids. Always load liquids at the center of the mixing chamber.

7.3 MIXING



DO NOT ENTER MIXING CHAMBER WHILE MIXER IS RUNNING! Shutoff and lockout power before attempting to clear an obstruction or to perform work inside the mixing chamber. Refer to section 5.3 SHUTOFF & LOCKOUT POWER.



Always operate at the rated PTO speed but **DO NOT EXCEED THE RATED PTO SPEED.** If the mixer is operated faster than the rated PTO speed the strain on the drive train and mixer is greatly increased.

Do not force hay into the auger with loader or any other device.

Normal mixing speed is 3/4 to full rated PTO speed. Time available to mix, thoroughness of the mix, and ingredients are all factors that must be considered when deciding on when and how fast to operate the mixer.

7.3.1 Mixing Troubleshooting Guide

PROBLEM	POSSIBLE SOLUTIONS
Forage Is Cut Too Short	<ul style="list-style-type: none"> • Reduce the initial processing time. • Adjust hay stops to a less aggressive or neutral position. (See Section 7.8 HAY STOP ADJUSTMENT) • Reduce total loading time. • Reduce the mixer RPM to limit aggressiveness in processing. • Modify the knife type, quantity, setting or placement. • Shift power shift transmission into “Low”.
Spillage Is Occurring	<ul style="list-style-type: none"> • Reduce Load Size. • Reduce tractor and/or mixer RPM. • Make sure machine is level. • The load size may need to be reduced until the unit is polished inside. • Adjust hay stops to a less aggressive or neutral position. • Adjust knives to a less aggressive position. • If spillage still occurs, the optional side extensions or hay retention ring may need to be installed.
Dead Spots	<ul style="list-style-type: none"> • The load size may need to be reduced until the unit is polished inside. • The auger scraper may need to be adjusted. (See Section 8.3.5 Auger Scraper Plate)

7.4 PLATFORM OPERATION

Park the tractor on a flat, level surface.

Engage the parking brake.

NOTE: *Always maintain a three-point contact at all times when getting on and off the ladder. Use the ladder rails and steps when climbing the ladder.*

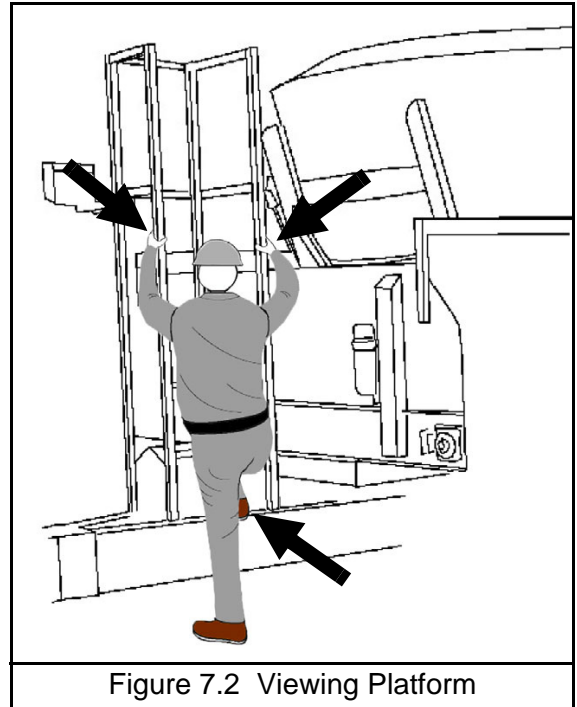

Figure 7.2 Viewing Platform

7.5 FOLDING LADDER

To unfold the ladder, release latch (Item 1) and pull ladder fully out (Item 2). To return ladder to storage position, pull ladder out to “unlock” it and guide the ladder support back up to its original position. Replace latch.

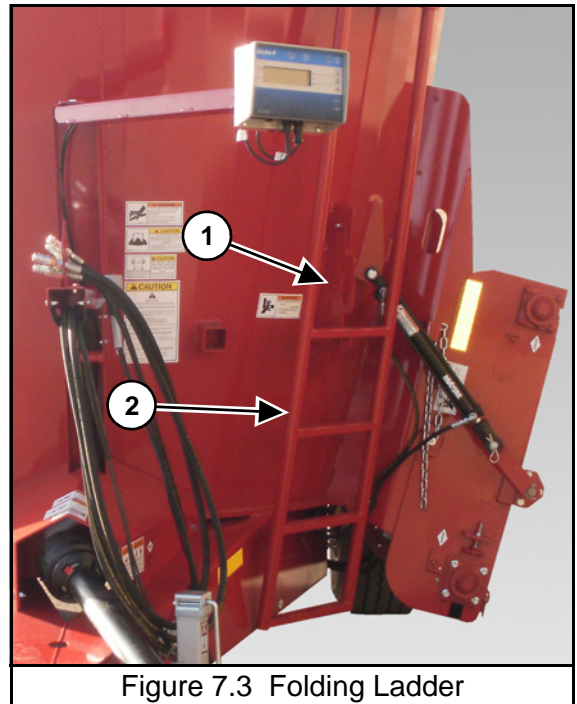

Figure 7.3 Folding Ladder

7.6 UNLOADING



DANGER

DO NOT ENTER MIXING CHAMBER WHILE MIXER IS RUNNING! Shutoff and lockout power before attempting to clear an obstruction or to perform work inside the mixing chamber. Refer to section 5.3 SHUTOFF & LOCKOUT POWER.



CAUTION

Shutoff and lockout power before adjusting, servicing, maintaining, or clearing an obstruction from this machine. Refer to section 5.3 SHUTOFF & LOCKOUT POWER.



IMPORTANT

Once PTO has been disengaged and a change of auger speed has been selected, allow at least 5 seconds for the stop & shift gearbox to complete the shift process before engaging PTO.

NOTE: Unload the mixed ration within a short time of mixing. A fully loaded mixer which is bounced over rough terrain or allowed to settle will require more horsepower during start-up.

1. Enter the tractor, start the engine, release the parking brake.
2. Move the tractor and mixer to the unloading area.
3. Be sure that mixer is parked on a level surface.
4. The tractor should be straight in line with the mixer.
5. Shift front sliding conveyor into working position or lower slide tray / conveyor (if equipped).

NOTE: Mixers equipped with a power shift transmission will automatically shift to low if the PTO RPM drops below 600 RPM while in "High".

6. For mixers equipped with a stop & shift gearbox, shift the gearbox into "Low" to ease the start of a full load for unloading.
7. Engage the PTO.
8. Set the tractor engine to operate at approximately 1/2 of rated PTO speed.
9. Open discharge door slowly to adjust the amount of material to be discharged. Adjust door height or conveyor speed for desired flow of feed.
10. After the load begins to discharge, increase the tractor RPM to full rated PTO speed to ensure fast and thorough clean out while driving forward along the discharge path.
11. During the unloading process, the mixer can be shifted into "High". See section 6.8.1 Controls for more details. This will help remove any feed remaining on the augers and assist in keeping an even flow until the mixer is empty.
12. When finished unloading, reduce engine speed to idle and disengage the PTO / hydraulics.
13. Move the mixer forward, away from the unloaded material.
14. Close the discharge door.
15. Shift front sliding conveyor into storage position or raise slide tray / conveyor (if equipped).
16. Park the mixer on a flat, level surface.
17. Engage the parking brake, stop the engine and exit the tractor.

7.7 UNHOOKING THE TRACTOR



WARNING

Keep hands, legs and feet from under tongue and hitch until jack is locked into place.

Jack is not designed to support the implement when it is loaded.

1. Park the implement on level ground. Put the tractor controls in neutral, set the parking brake, and turn the engine off before dismounting.
2. Place wheel chocks in front and in back of the implement wheels on opposite sides to prevent the implement from rolling after the tractor is unhooked.
3. Disconnect the PTO drive shaft.
4. Remove the hydraulic hose ends from the tractor hydraulic ports and secure the hose ends in the key slot holes on the front of the mixer to keep them clean.
5. Remove the light cords and any optional equipment connections.
6. Remove the jack from the storage mount and reinstall the jack on the hitch tongue. Crank the jack down until the hitch lifts off the tractor drawbar.
7. Remove the hitch pin.
8. Unhook safety chain from tractor drawbar and intermediate support.
9. Slowly drive the tractor away from the implement.

7.8 HAY STOP ADJUSTMENT

CAUTION

DO NOT adjust the hay stops while the mixer is running. Moving feed inside the mixer can make the hay stop move suddenly causing injury to the person making the adjustment.

IMPORTANT

Never operate the mixer without the hay stop lock bolt installed.

7.8.1 Hay Stop Lock Bolt

The hay stop lock bolt (Item 1) prevents the hay stop from rotating past the intended range of operation. If the hay stop bolt and the positioning pin (Item 2) are removed, the hay stop could contact the moving auger and cause damage to the hay stop and auger.

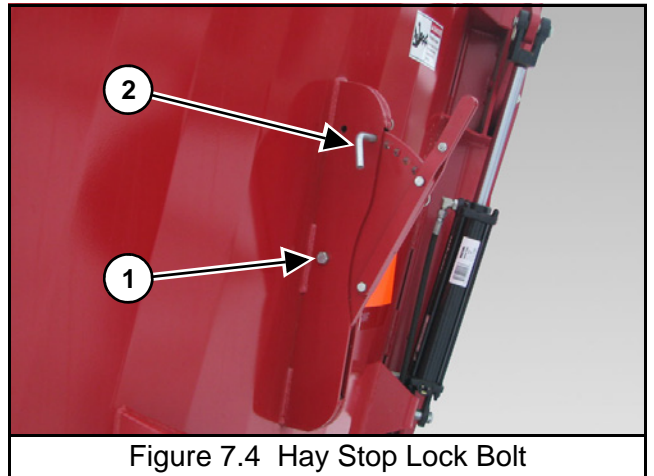

Figure 7.4 Hay Stop Lock Bolt

Position	Setting	Material
A	High	Light And Bulky Material (Dry Grasses)
B	Medium High	Alfalfa Bales And Other Forages
C	Neutral	Unrestrained Movement Of Feed
D	Medium Low	Heavier Rations
E	Low	Aggressive Cutting

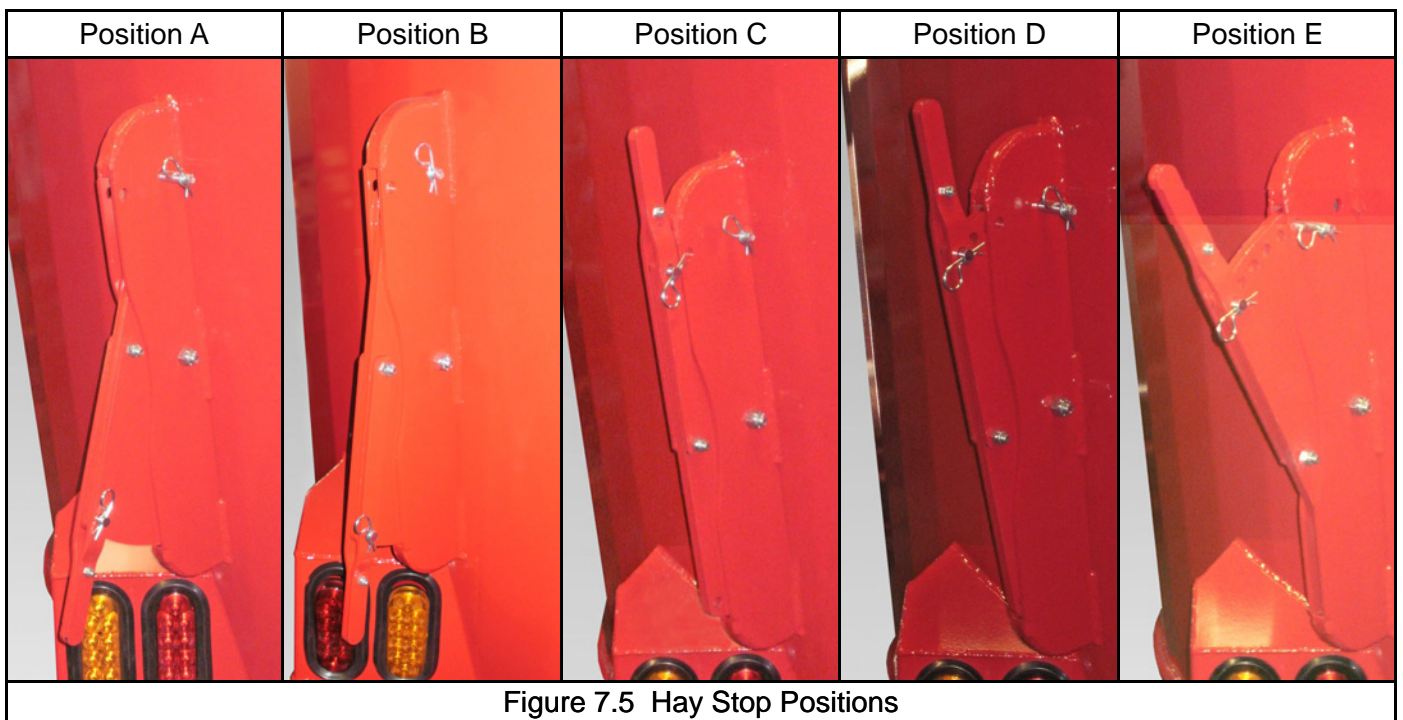

Figure 7.5 Hay Stop Positions



8.0 MAINTENANCE

8.1 GENERAL



Shutoff and lockout power before adjusting, servicing, maintaining, or clearing an obstruction from this machine. Refer to section 5.3 SHUTOFF & LOCKOUT POWER.

IMPORTANT

When welding do not allow electrical current to flow through bearings, roller chains, or scale weigh bars. Ground the welder directly to the part being welded. Always disconnect the power cord from scale indicator before welding.

8.2 LUBRICATION



Shutoff and lockout power before adjusting, servicing, maintaining, or clearing an obstruction from this machine. Refer to section 5.3 SHUTOFF & LOCKOUT POWER.

IMPORTANT

Fluid such as hydraulic fluid, grease, etc., must be disposed of in an environmentally safe manner. Some regulations require that certain spills and leaks on the ground must be cleaned in a specific manner. See local, state and federal regulations for the correct disposal.

NOTES:

- *Use a grease type that is composed of a high quality lithium complex or better, unless otherwise stated. We recommend using a #1 grade in colder temperatures or a #2 grade in warmer temperatures.*
- *We recommend using a 4-jaw grease coupling to allow greasing of both imperial and metric style grease fittings.*
- *Over lubrication is a major cause of bearing failures. Please lubricate conservatively when unsure of bearing requirements.*
- *Do not mix synthetic and mineral oils.*

8.2.1 Daily Lubrication

Check the planetary gearbox oil levels daily to prevent abnormal component wear. Add new oil to the planetary reservoir tank (See 8.2.14.1 Planetary Gearbox) if the oil level is not at the oil reservoir mark (Item 1).

Check for any oil leaks. If leaks occur, correct the source of the leak.

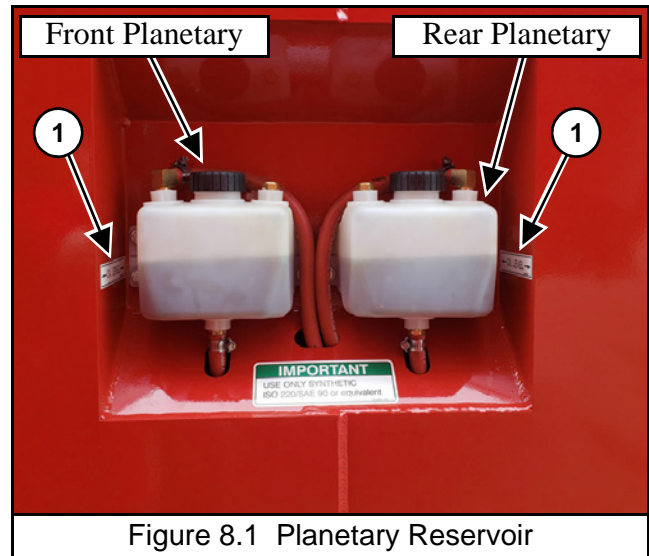

Figure 8.1 Planetary Reservoir

Check the 585 & 700 gearbox oil level daily to prevent abnormal component wear. Add new oil to the reservoir tank (Item 2) (See 8.2.14.2 Stop & Shift Gearbox (If Equipped)) if the oil level is not at the oil reservoir mark.

Check for any oil leaks. If leaks occur, correct the source of the leak

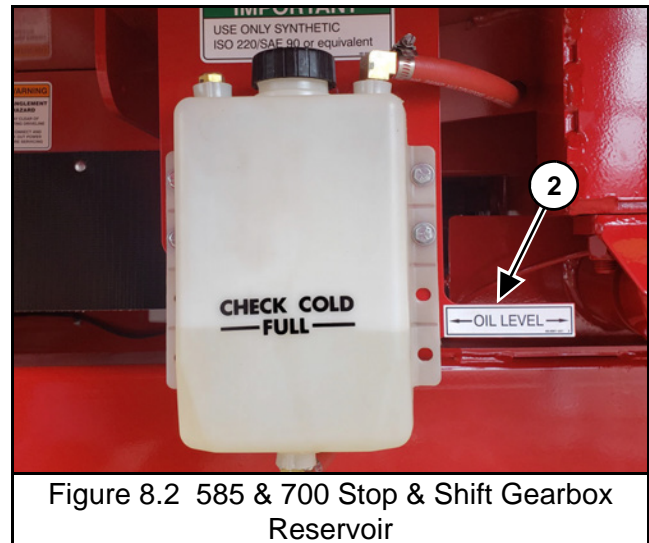

Figure 8.2 585 & 700 Stop & Shift Gearbox Reservoir

Check the F2-585 & F2-700 stop & shift gearbox oil level daily to prevent abnormal component wear (If Equipped). Add new oil to the gearbox (Item 3) (See 8.2.14.2 Stop & Shift Gearbox (If Equipped)) if the oil level is not at the sight glass (Item 4).

Check for any oil leaks. If leaks occur, correct the source of the leak

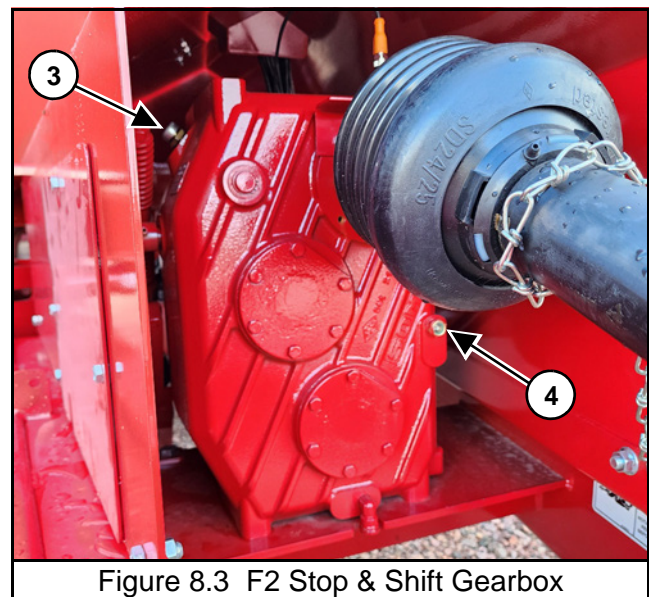

Figure 8.3 F2 Stop & Shift Gearbox

Check the power shift transmission oil level daily to prevent abnormal component wear. Add new oil to the transmission (If Equipped). Add new oil to the power shift transmission (See 8.2.14.3 Power Shift Transmission (If Equipped)) if the oil level is not at the sight glass (Item 5).

Check for any oil leaks. If leaks occur, correct the source of the leak.

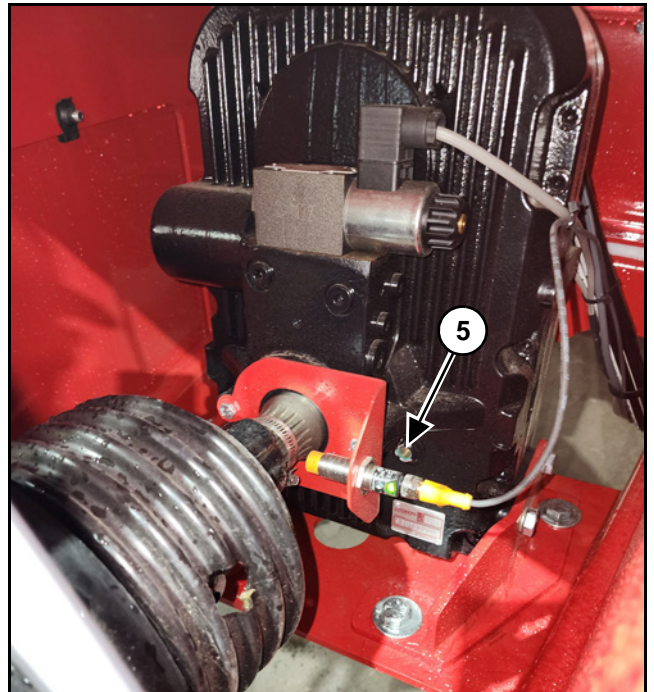
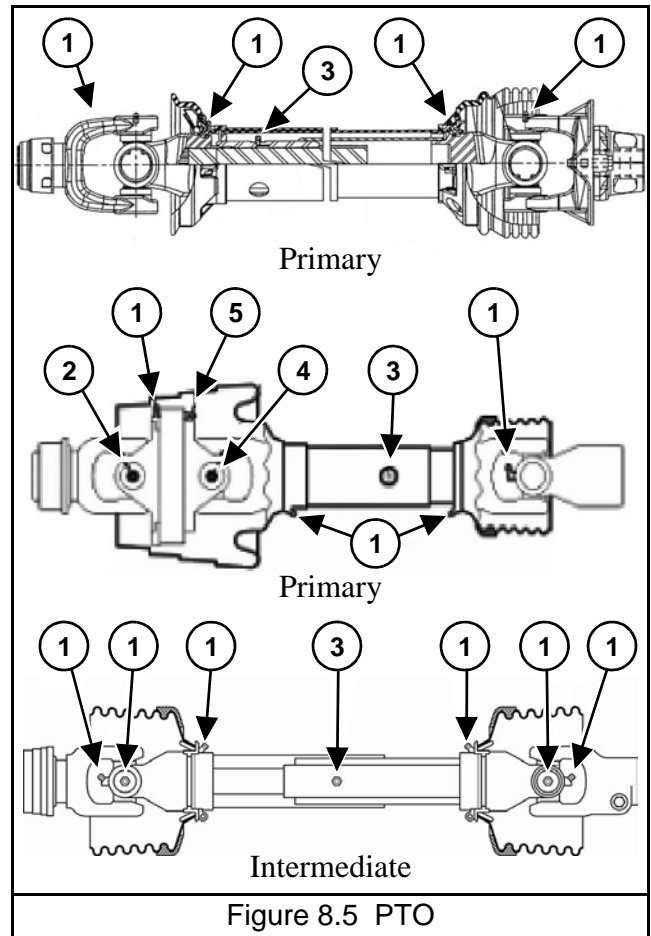

Figure 8.4 Power Shift Transmission Sight Glass

8.2.2 Every 8 Hours

Grease all PTO driveline zerks

1. Grease PTO locations every 8 hours.
2. Lubricate the outer CV cross kit with about 5 pumps of grease every 8 hours.
3. Grease telescoping members until it adequately covers the sliding members every 8 hours. Take apart occasionally to make sure adequate lubrication is being added. Take apart each season to be cleaned with solvent and re-coated with grease before re-assembling.
4. Lubricate the inner CV cross kit with about 15 pumps of grease every 8 hours.
5. Lubricate the double yoke with about 10 pumps of grease every 8 hours.



Grease all universal joints (Item 6) and the slide (Item 7) (If Equipped).

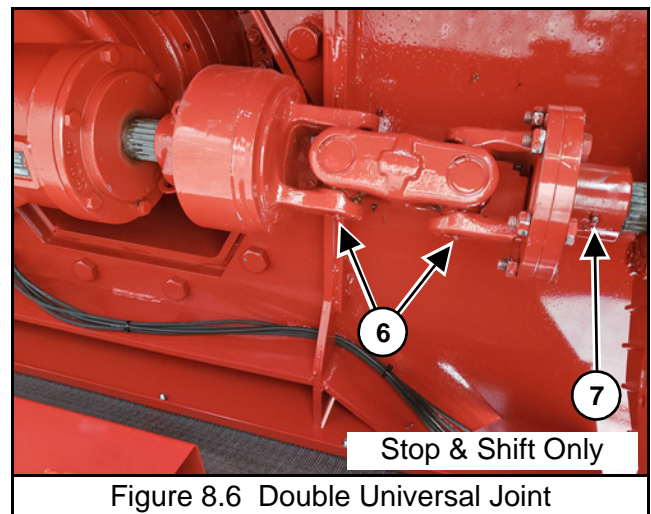

8.2.3 Weekly Lubrication

Clean out under chain return shield (Item 3) (If Equipped).

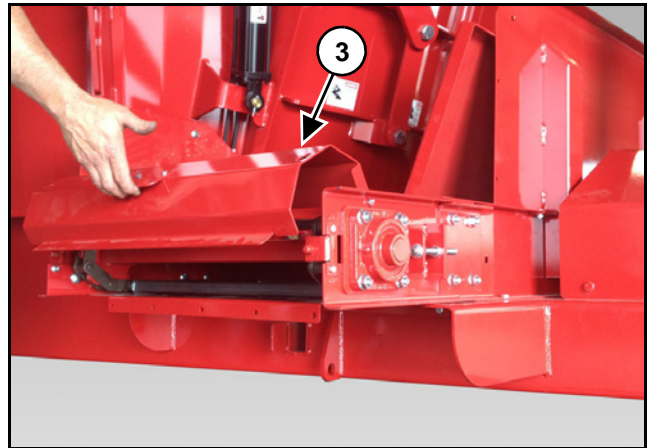

Figure 8.7 Front Chain Conveyor Return

8.2.4 Monthly Lubrication

Grease the hubs through the zerk (Item 1) in each hub (If Equipped). Be careful not to over grease and force the seal out of the back side of the hub.

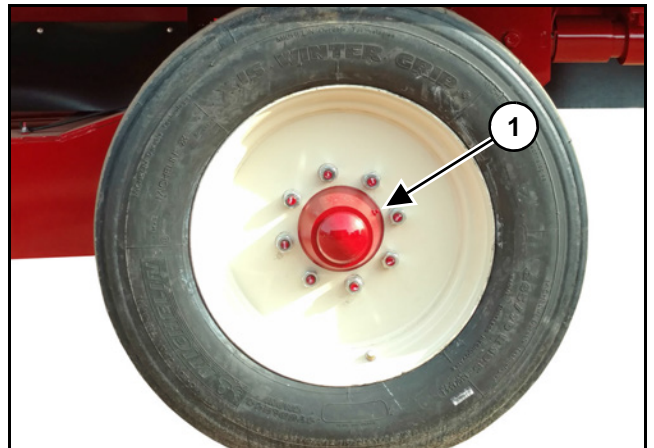

Figure 8.8 Grease Lubricated Wheel Hub

Grease the tandem inner / outer bearings (Item 2) (If Equipped).

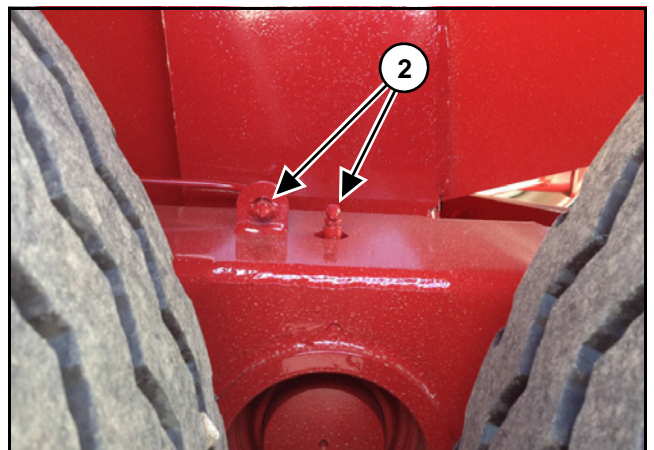

Figure 8.9 Tandem Trailer Inner/Outer Bearing

8.2.5 Every 40 Hours

Oil door pivots (Item 1).

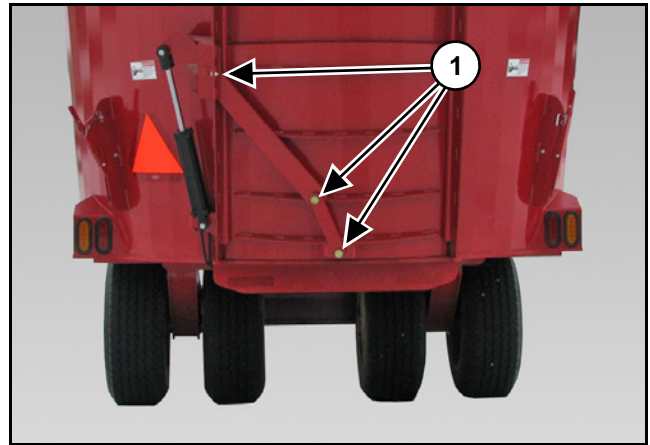

Figure 8.10 Door Pivots

8.2.6 First 50 Hours

First oil change in the planetaries (See 8.2.14.1 Planetary Gearbox).

First oil change in the stop & shift gearbox (If Equipped).
(See 8.2.14.2 Stop & Shift Gearbox (If Equipped))

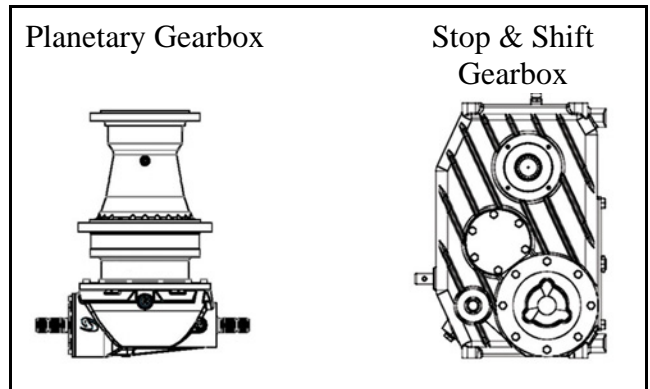

Figure 8.11 Planetary / Stop & Shift Gearbox

8.2.7 Every 250 Hours

NOTES:

- *The number of input bearings will vary depending upon your model mixer.*
- *Shielding has been removed for illustration purposes only.*

Grease all 585 & 700 input bearings with 1 pump of grease (Item 1). Be careful not to over grease.

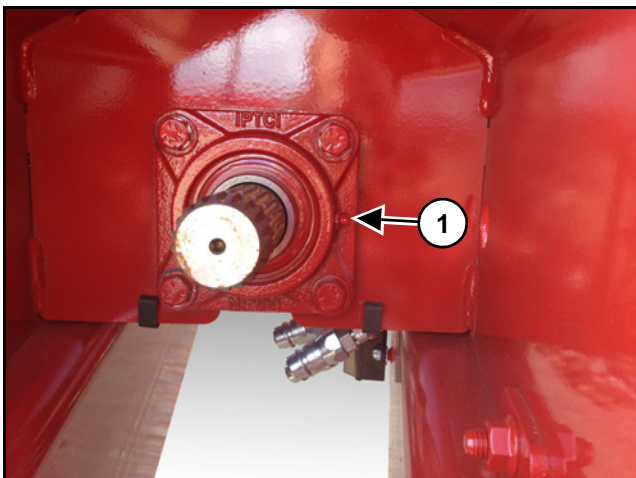

Figure 8.12 Front Input Shaft Bearing

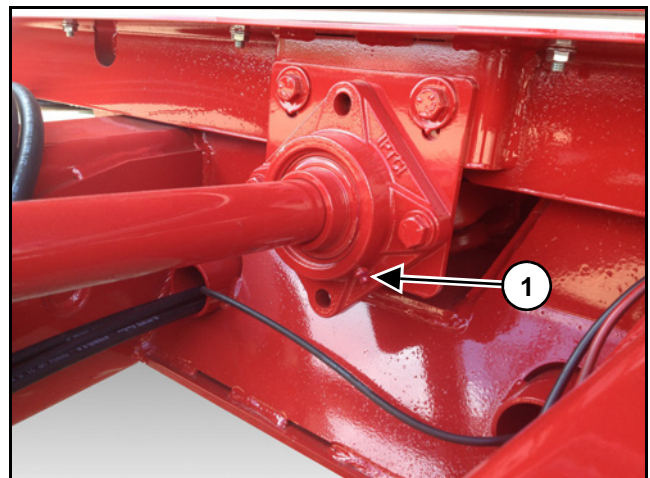

Figure 8.13 Rear Input Shaft Bearing

Grease all F2-585 & F2-700 direct drive input bearings (If Equipped) with 1 pump of grease (Item 2). Be careful not to over grease.

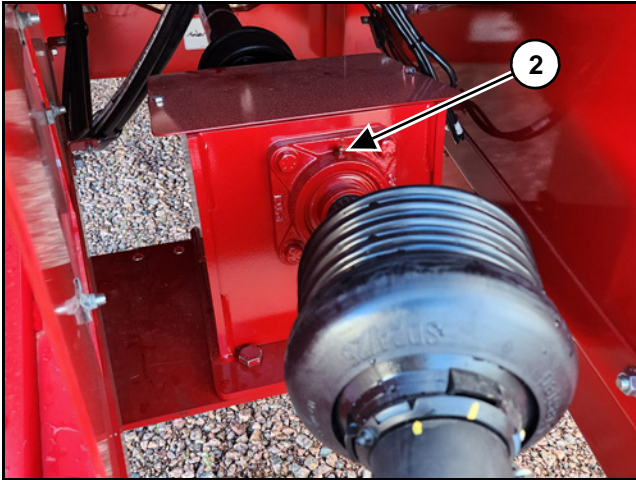

Figure 8.14 F2 Front Input Shaft Bearing

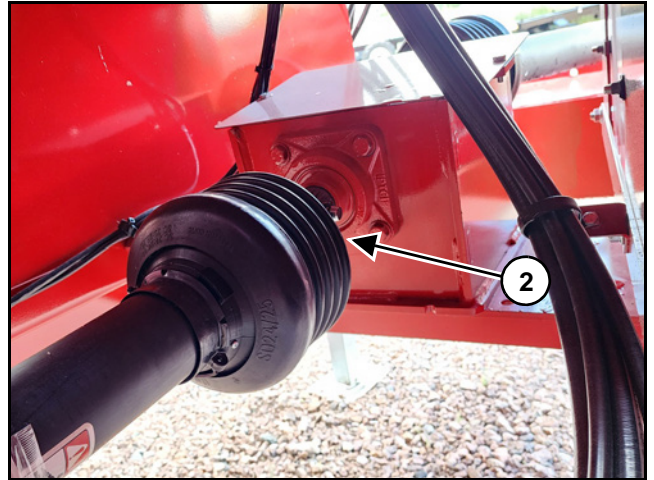

Figure 8.15 F2 Rear Input Shaft Bearing

Grease the four (4) front cross conveyor bearings (Item 3) (If Equipped).

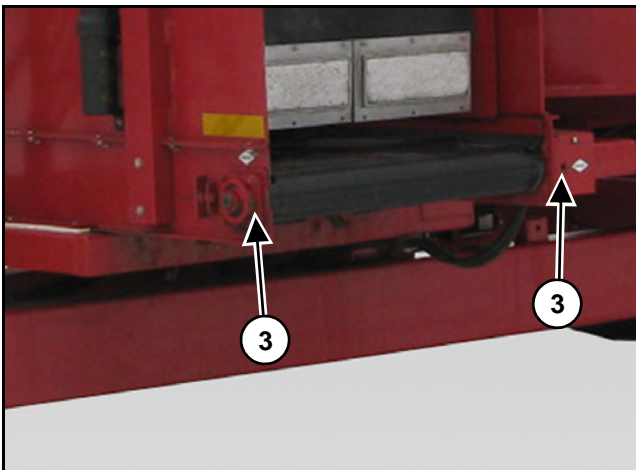

Figure 8.16 Front Cross Conveyor - Left Side

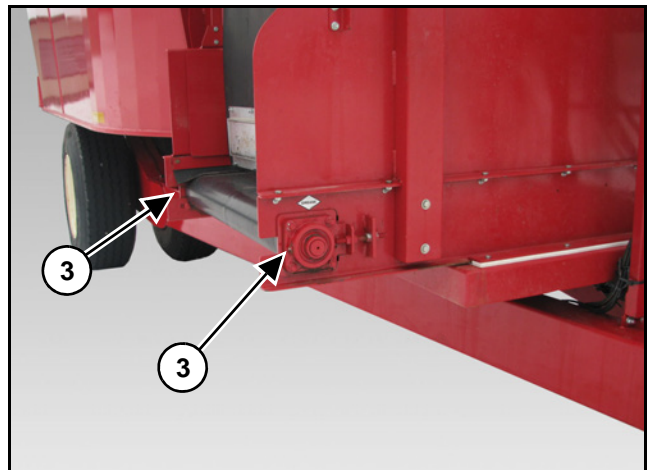

Figure 8.17 Front Cross Conveyor - Right Side

Grease the four (4) side door conveyor bearings (Item 4) (both sides) (If Equipped).

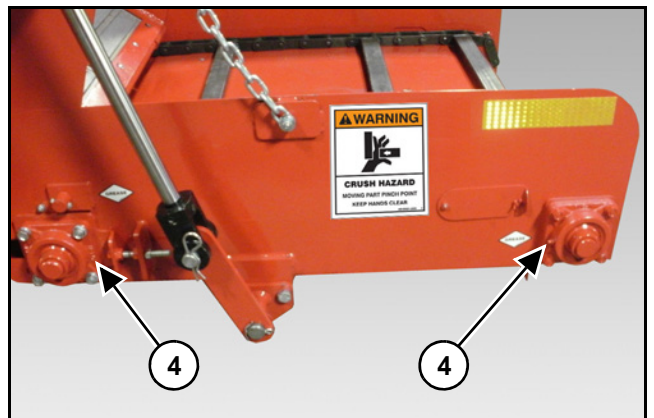
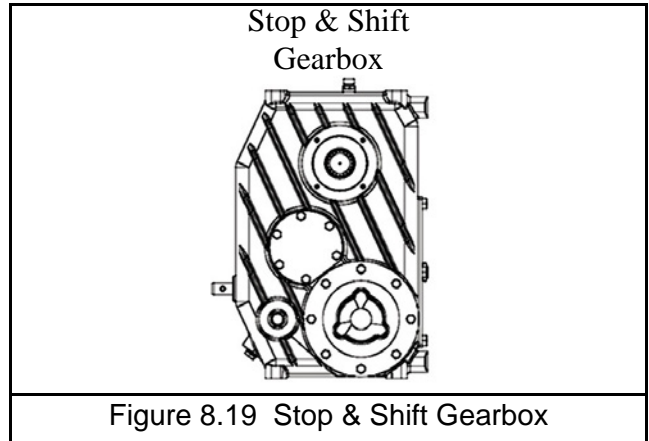

Figure 8.18 Side Door Conveyor Option

8.2.8 Semiannually or Every 500 - 600 Hours (Whichever Is First)

Change oil in the stop & shift gearbox (If Equipped). (See 8.2.14.2 Stop & Shift Gearbox (If Equipped))



8.2.9 Annually

Clean and repack the grease lubricated wheel hubs with axle grease (If Equipped). (See 8.2.13 Grease Hubs Procedure)



8.2.10 Annually or Every 1000 Hours (Whichever Is First)

Change the power shift transmission oil and filter (If Equipped). (See 8.1.14.3 Automatic Transmission (If Equipped))

(Filter Element Part Number: 119-Z-26-1)

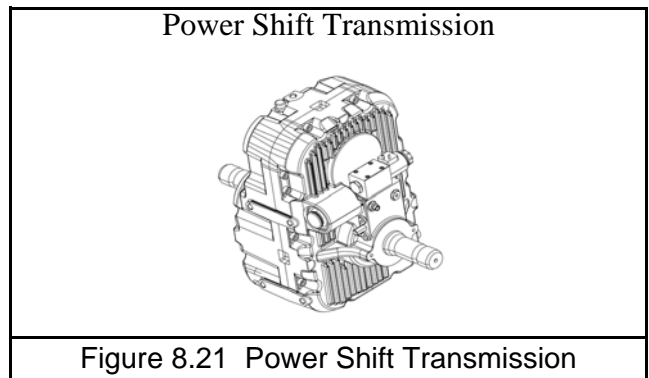

8.2.11 Annually or Every 2000 Hours (Whichever Is First)

Change oil in the planetary gearboxes. (See 8.2.14.1 Planetary Gearbox)

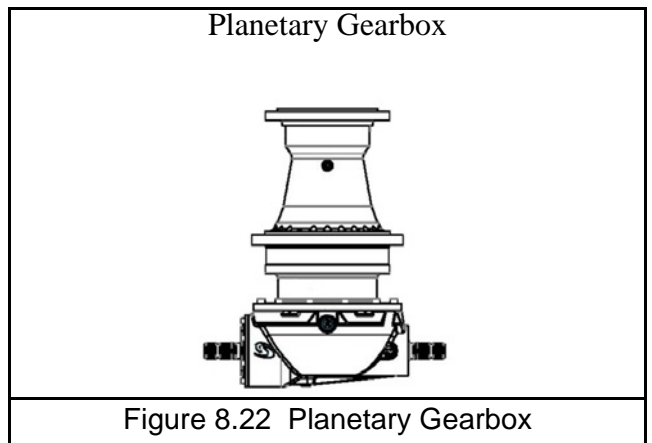

8.2.12 Every 5000 Hours

Replace all planetary bearings.

Change external planetary O-rings.

Check the extent of wear on all planetary gears.

8.2.13 Grease Hubs Procedure

- Use a pressure packer to pack the bearing cones with grease by forcing grease into the cavities between the rollers and cage from the large end of the cone. If a pressure packer is not available, pack the bearings by hand.
- Apply a light coat of grease to the spindle bearing journals.
- Pack the area of the hub between the two bearings with grease up to the smallest diameter of the bearing cups. Remove excess grease.
- Install and tighten the hub retention hardware. Apply a light coat of approved NLGI 1 or 2 grease to the hubcap interior and across the face of the outer locknut. This will indicate that NLGI 1 or 2 grease was used, as well as help prevent corrosion of these parts.

8.2.14 Gearbox/Transmission Oil & Filter Change Procedures



Shutoff and lockout power before adjusting, servicing, maintaining, or clearing an obstruction from this machine. Refer to section 5.3 SHUTOFF & LOCKOUT POWER.



Fluid such as hydraulic fluid, grease, etc., must be disposed of in an environmentally safe manner. Some regulations require that certain spills and leaks on the ground must be cleaned in a specific manner. See local, state and federal regulations for the correct disposal.

NOTES:

- *In order to avoid sludge deposits, change the oil while the gear unit is still warm.*
- *For an effective oil change, the unit should be flushed with a liquid detergent recommended by the lubricant supplier.*
- *The mixer should be level when changing gearbox oil.*

8.2.14.1 Planetary Gearbox

Draining

- Place a container of sufficient capacity under the gearbox (Item 4). Remove the planetary reservoir (Item 2) cap (Item 3).
- Drain the planetary by removing the drain plug (Item 5).
- After the planetary is completely drained, reinstall the drain plug.

Filling

Filling with an oil pump:

(Call the factory to purchase an oil pump kit, Part #: VA-OP.)

- Loosen the hose clamp and detach the lower hose (Item 1) on the reservoir (Item 2). Unbolt the reservoir and lay so the top hose and reservoir are below the lower hose used for filling (Item 1).
- Connect oil pump to the lower hose (Item 1) and fill with oil until the reservoir (Item 2) fills with approximately 2 quarts of oil. Discard this oil if it is dirty.
- Reattach the lower reservoir hose (Item 1) with the hose clamp.
- Bolt the reservoir back in place.
- Fill the reservoir to the oil level mark (Item 6) and reinstall the cap (Item 3).

NOTE: See Planetary Lubrication Specifications table for oil type and approximate capacities.

- Inspect the reservoir breather, make sure it is not plugged, and check for leaks.

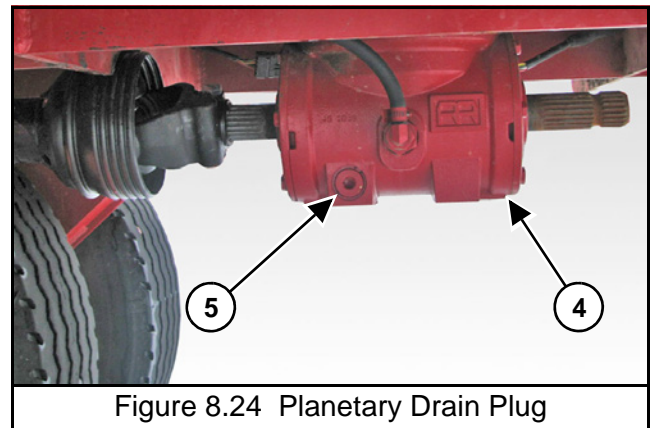
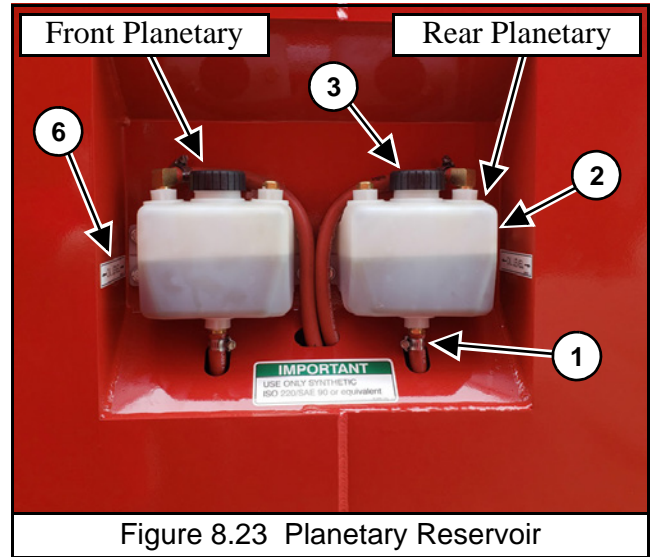

PLANETARY LUBRICATION SPECIFICATIONS				
Model	Part Number	Description	Oil Type	Capacity Per Planetary (Including Reservoir) (Approximate)
585 & 700	119-18-13.92-1	1800 Planetary 13.92:1	Synthetic ISO 220 Or Equivalent	14.8 Quarts
F2-585 & F2-700	119-21-25.67-1	2100 Planetary 25.67:1	Synthetic ISO 220 Or Equivalent	18.5 Quart

8.2.14.2 Stop & Shift Gearbox (If Equipped)

IMPORTANT

Check the gearbox oil levels regularly to prevent abnormal component wear. Add oil to the reservoir tank if oil level is not at the oil level mark.

585 & 700 MIXER MODELS

Draining

- Place a container of sufficient capacity under the gearbox.
- Drain the unit by removing the plug from the bottom of the gearbox.
- After the unit is completely drained, reinstall the plug.

Filling

- Remove reservoir filler cap (Item 1) and fill with oil to the oil level mark (Item 2).

NOTE: See *stop & shift Gearbox Lubrication Specifications table for oil type and approximate capacities.*

- Replace reservoir filler cap.
- Inspect the reservoir breather, make sure it is not plugged, and check for leaks.

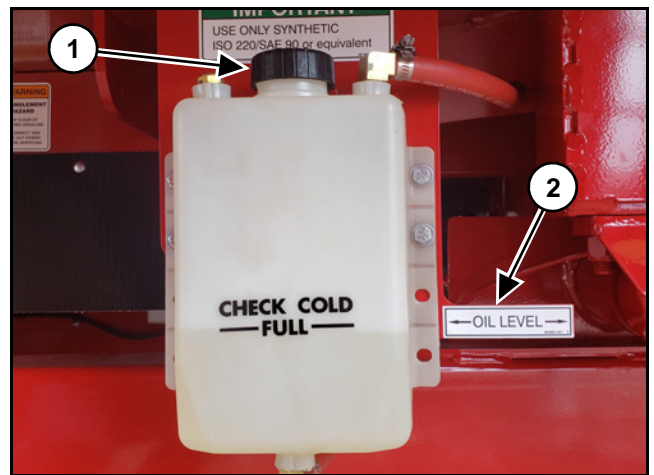

Figure 8.25 Stop & Shift Gearbox Reservoir

F2-585 & F2-700 MIXER MODELS

Draining

- Place a container of sufficient capacity under the gearbox.
- Drain the unit by removing the plug from the bottom of the gearbox (Item 5).
- After the unit is completely drained, reinstall the plug.

Filling

- Remove breather plug (Item 3) and fill with oil to the sight glass (Item 4).

NOTE: See *stop & shift Gearbox Lubrication Specifications table for oil type and approximate capacities.*

- Inspect the breather to make sure it is not plugged.
- Replace breather plug and check for leaks.

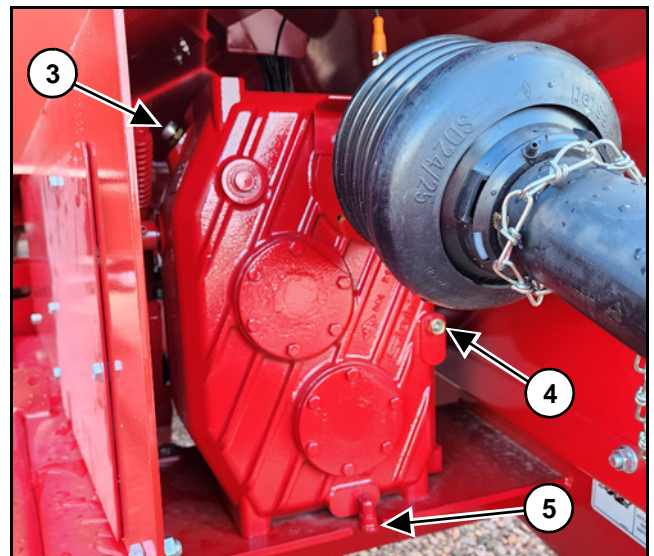

Figure 8.26 F2 Stop & Shift Gearbox

STOP & SHIFT GEARBOX LUBRICATION SPECIFICATIONS

Model	Part Number	Description	Oil Type	Capacity (Including Reservoir) (Approximate)
585 & 700	119-2SP-1.5-2.7-1	1.51:1 / 2.73:1	Synthetic ISO 220 Or Equivalent	10.5 Quarts
F2-585 & F2-700	119-2SP-1.0-1.5-6	1.00:1 / 1.50:1	Synthetic ISO 220 Or Equivalent	6.75 Quarts

8.2.14.3 Power Shift Transmission (If Equipped)

IMPORTANT

Check the transmission oil levels regularly to prevent abnormal component wear. Add oil to the transmission if oil level is not at the oil level mark.

Draining

- Be sure the mixer is positioned on level ground/surface.
- Place a container of sufficient capacity under the transmission.
- Drain the unit by removing the plug (Item 4) from the bottom of the transmission.
- After the unit is completely drained, reinstall the plug.

Filter Replacement

- Remove filter snap ring and cap (Item 1).
- Remove old filter taking note of spring location.
- Lubricate the O-ring with clean oil.
- Place the new filter element carefully onto the element spigot with the spring in its proper location.
- Reinstall the filter cap and snap ring.

Filling

- Remove breather/filler plug (Item 2).
- Fill transmission until the oil level has reached the sight glass (Item 3).

NOTE: See Power Shift Transmission Lubrication Specifications table for oil type and approximate capacities.

- Replace the breather/filler plug.
- Run the transmission with no load for a few minutes, switching from low to high gear several times.
- Check the oil level and add if necessary.
- Inspect the breather, make sure it is not plugged, and check for leaks.

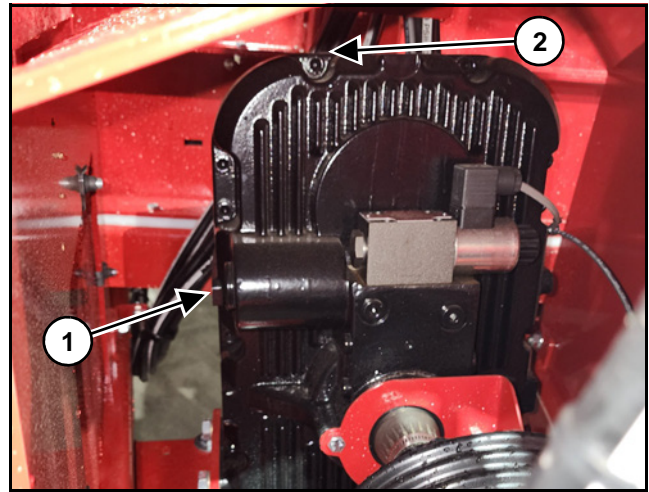

Figure 8.27 Power Shift Transmission Filter

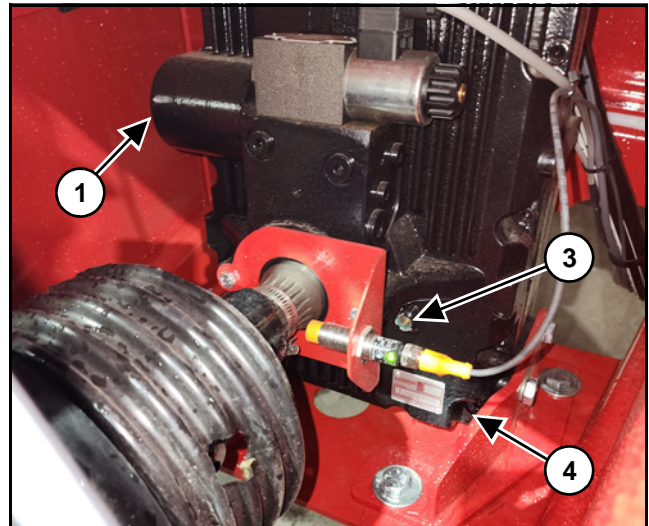

Figure 8.28 Power Shift Transmission

POWER SHIFT TRANSMISSION LUBRICATION SPECIFICATIONS				
Model	Part Number	Description	Oil Type	Capacity (Including Filter) (Approximate)
F2-585 & F2-700	119-2SP-1.0-1.77-2	1.00:1 / 1.77:1	See Approved Fluid Table	4.3 Quarts

POWER SHIFT TRANSMISSION FLUID (ATF) OIL						Revision: 00 Latest Update: 07-2017	
Supplier:	Product Name:	Viscosity @40°C:	Viscosity @100°C:	Viscosity Index:	Pour Point:	STATUS	
						Recommended	Approved
AGCO	AGCO PERMATRAN 821XL T&H OIL SAE 10W30	58	9.2	141	-33°C		X
BP	BP VANELLUS AGRI SUPER TRANSMISSION 80W	57	10.2	167	-39°C	X	X
CASTROL	CASTROL AGRI TRANS PLUS 80W	55	9.8	161	-45°C		X
CLAAS	CLAAS AGRISHIFT GA12	59	10.2	155	-39°C		X
EXXONMOBIL	MOBILFLUID 424	55	9.3	145	-42°C		X
EXXONMOBIL	MOBILFLUID 426	59	9.7	149	-36°C		X
FUCHS	FUCH AGRIFARM UTTO MP	56	9.3	147	-42°C		X
JOHN DEERE	JOHN DEERE HY-GARD	59	9.4	140	-40°C		X
KUBOTA	KUBOTA UDT	62	10.1	148	-45°C		X
KUWAIT PETROLEUM	Q8 T2200	55	9.8	165	-30°C		X
MASSEY FERGUSON	MASSEY FERGUSON PERMATRAN T&H OIL SAE 10W30	58	9.2	141	-33°C		X
PETRONAS	PETRONAS ARBOR MTF 10W30	58	9.5	147	-40°C		X
PETRONAS/ CNH	AMBRA MULTI-G	N/A	9.5	140	-40°C		X
PETRONAS/ CNH	CASE AKCELA HY-TRAN ULTRACTION	57	9.3	145	-39°C		X
PETRONAS/ CNH	NH AMBRA MASTERTRAN ULTRACTION	57	9.3	145	-42°C		X
SHELL	SHELL SPIRAX S4 TXM	60	9.4	138	-42°C		X
SHELL	SHELL SPIRAX S6 TXME	64	10.4	151	-48°C		X
TOTAL	TOTAL DYNATRANS MPV	64	10.4	150	-39°C		X
TOTAL	ELF TRACTELF BF 16	59	10.1	153	-33°C		X
VALVOLINE	UNITRAC 80W	63	10.0	143	-39°C		X
ATF-Oil With The Defined Specifications		<62	>9.0	>140	<-35°C		X

8.3 ADJUSTMENTS



Shutoff and lockout power before adjusting, servicing, maintaining, or clearing an obstruction from this machine. Refer to section 5.3 SHUTOFF & LOCKOUT POWER.

If work must be done inside the mixer, put a protective cover over the auger knives to avoid injury. The hopper and flighting may be slippery. Use caution when stepping on or standing inside the mixer.

8.3.1 Side Discharge Conveyor

To adjust tension of the chain, loosen the inner nut (Item 1) and either tighten or loosen the outer nut (Item 2) as needed. Count the number of turns you are adjusting so you can adjust the other end. Once you have proper tension, re-tighten the inner nut (Item 1) on both sides.

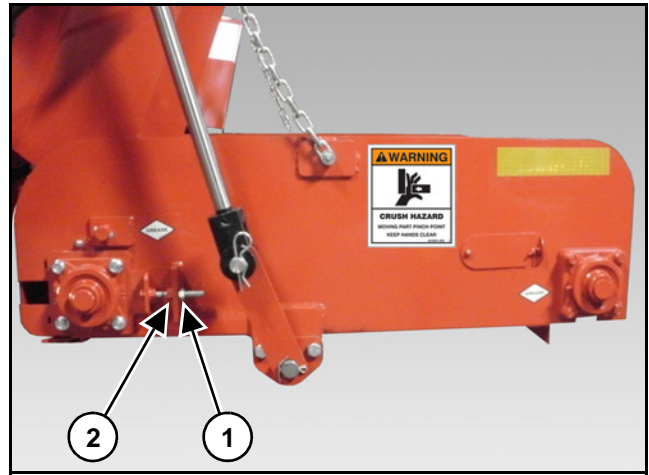

Figure 8.29 Side Discharge Conveyor

8.3.2 Belt Conveyor Tension

IMPORTANT

Check belt tension often. Belts can tighten with use. Overtightening can cause damage to belt.

Front Conveyor:

Tension the belt (Item 1) so as the belt is flush with the bottom radius (Item 2) of conveyor side rails.

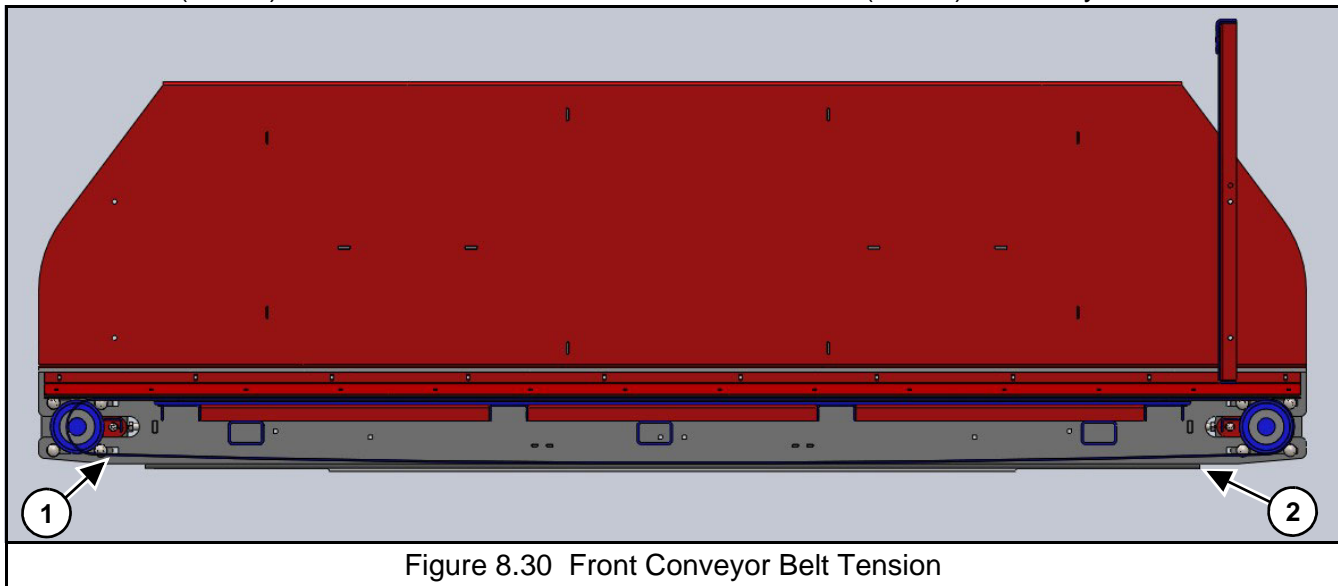

Figure 8.30 Front Conveyor Belt Tension

Incline/Side Discharge Conveyor:

Tension the belt (Item 3) so as the midpoint between both rollers hangs 7/8" lower than at the rollers (Item 4).

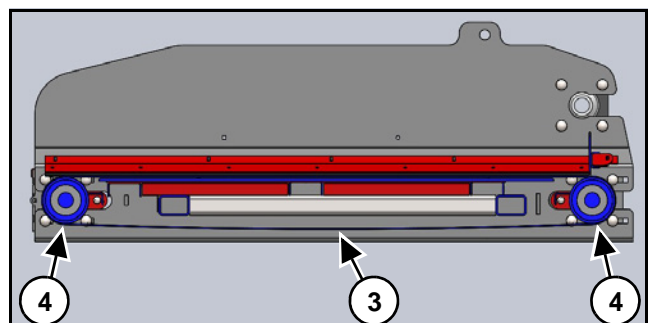

Figure 8.31 Incline/Side Conveyor Belt Tension

8.3.3 Tracking

NOTE: The primary discharge side for the two motor flat conveyor is the side that is used for discharge the most.

Step 1: Loosen the lock nuts (Item 1) holding the four bearings to the conveyor. Loosen the tightener nuts (Item 2) on all adjuster locations. Do not loosen the scraper bolts (Item 3).

Step 2: Locate the primary discharge side of the conveyor.

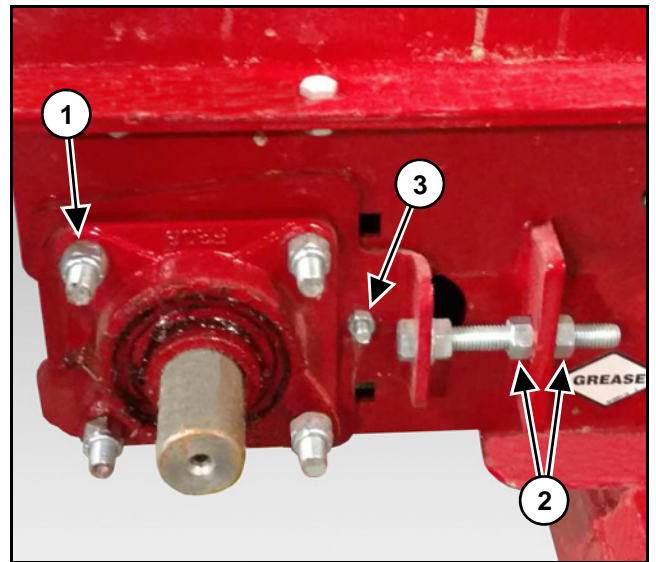

Figure 8.32 Conveyor Adjusters

Step 3: Set the primary side as follows:

Use the primary side adjusters to remove at least half of the belts slack. Measure, as shown below, until both sides of the drive pulley shaft (Item 4) are set at exactly the same from the end of the conveyor frame (Item 5).

Step 4: Once the primary drive pulley is set and square, tighten the lock nuts on both primary drive pulley bearings. Lock both adjusters on the primary drive pulley.

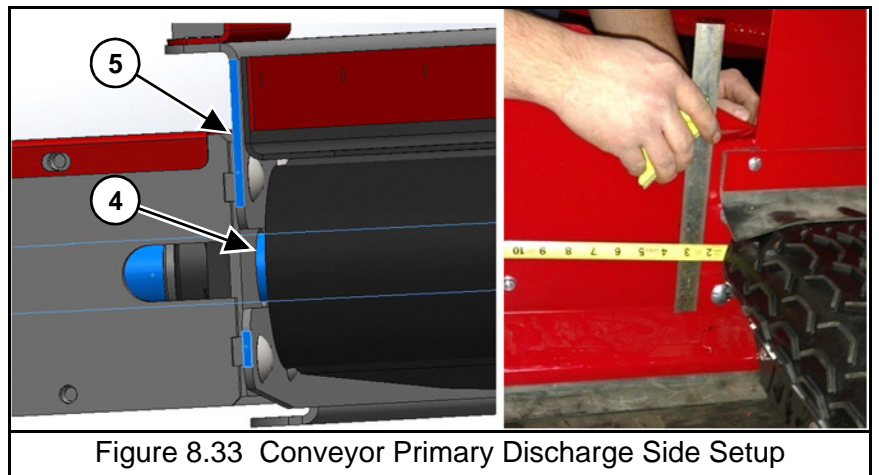

Figure 8.33 Conveyor Primary Discharge Side Setup

Step 5: With the primary discharge drive pulley set, move to the other side of the conveyor. Start to evenly tighten the belt by alternating sides on the non-primary discharge pulley adjusters. Tighten until the lowest hanging part of the belt is flush with the bottom of the conveyor frame. Once the belt is tight (Do not over tighten belt), measure the distance from the non-primary discharge shaft to the end of the conveyor frame, same as shown in Step 3. Do that for both shaft ends of the non-primary discharge pulley.

Step 6: Take the shortest measurement from either end and set both ends of the non-primary discharge pulley to the same measurement.

NOTE: If you run out of adjustment on the non-primary side, repeat Step 3 and remove more slack from the belt using the primary side.

Step 7: With the belt tightened as shown in section 8.3.2 Belt Conveyor Tension and the non-primary discharge pulley square with the conveyor frame, tighten the adjuster lock nuts for both non-primary discharge pulley bearings.

Step 8: Run the mixer conveyor for 2-3 minutes (both directions for front flat conveyors) at full RPM. If you notice the belt walking to the left or right while looking at the primary discharge end of the conveyor, stop the conveyor. Check your measurements to make sure both primary and non-primary discharge pulleys are square with the conveyor frame. If the conveyor pulleys are square but the belt continues to walk, use the images below to unlock and tighten the corresponding non-primary discharge pulley bearing adjuster (See Below). Continue to slightly adjust and run the conveyor until the belt stops walking.

NOTE: *If the center v of the belt is completely out of the pulley groove, you may have to loosen both non-primary pulley adjusters to center the belt. Re-tighten to your measurement used in Step 6 before adjusting the conveyor as shown below.*

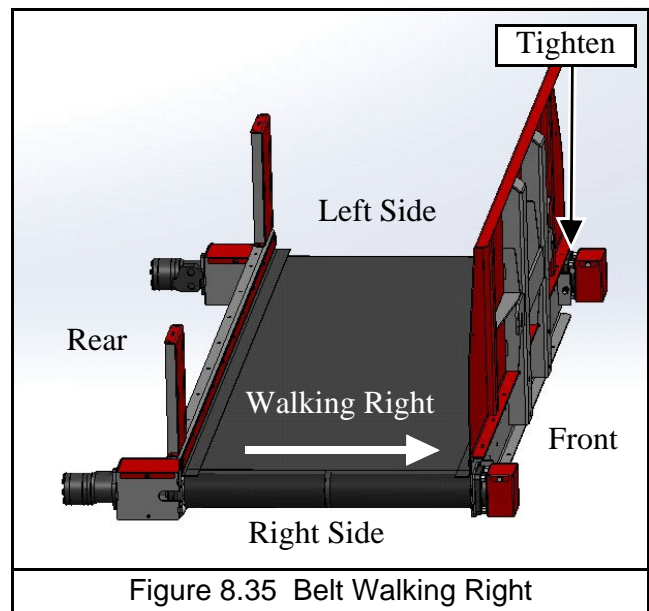
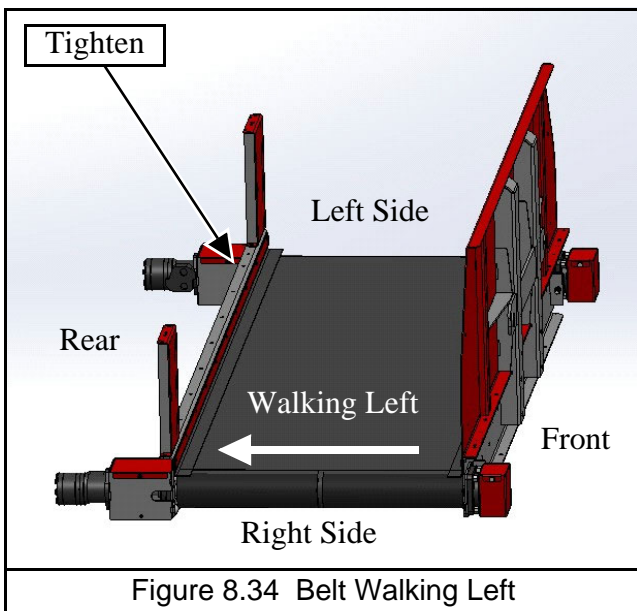

NOTE: *Both images are viewed as if the conveyor is a right primary discharge.*

Step 9: With the belt conveyor tracking properly, make sure all bearing bolts are tight and adjusters are locked.

Step 10: Watch the conveyor when discharging your feed ration to make sure the belt doesn't slip. If the belt is slipping, evenly tighten the non-primary discharge side. Run and check belt alignment. Repeat as necessary.

Step 11: Watch the conveyor when discharging your feed ration to make sure the belt doesn't slip. If the belt is slipping, evenly tighten the non-primary discharge side. Run and check belt alignment. Repeat as necessary.

NOTE: *If you run out of adjustment on the non-primary side, repeat Step 3 and remove more slack from the belt using the primary side.*

8.3.4 Front Discharge Conveyor - Chain

To adjust tension of the chain, loosen the inner nut (Item 1) and either tighten or loosen the outer nut (Item 2) as needed. Count the number of turns you are adjusting so you can adjust the other end. Once you have proper tension, re-tighten the inner nut (Item 1) on both sides.

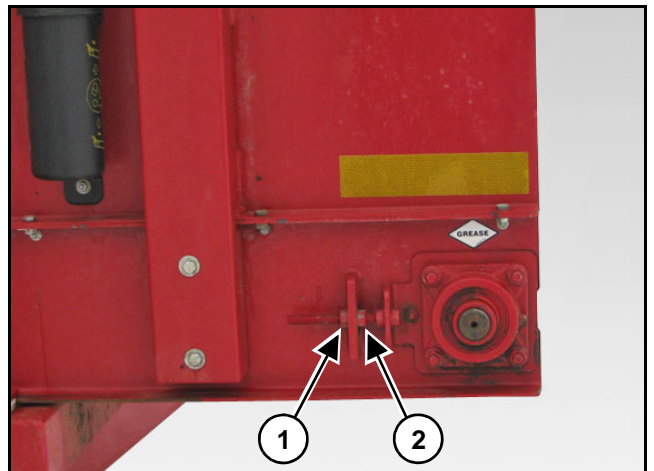

Figure 8.36 Chain Conveyor Adjusters

8.3.5 Auger Scraper Plate

Check the auger scraper monthly for proper clearance with the side panel. Locate the closest point along the augers rotation that the scraper comes to the baffles. Adjust the scraper to a 1/16" from the located closest point as shown in the image.

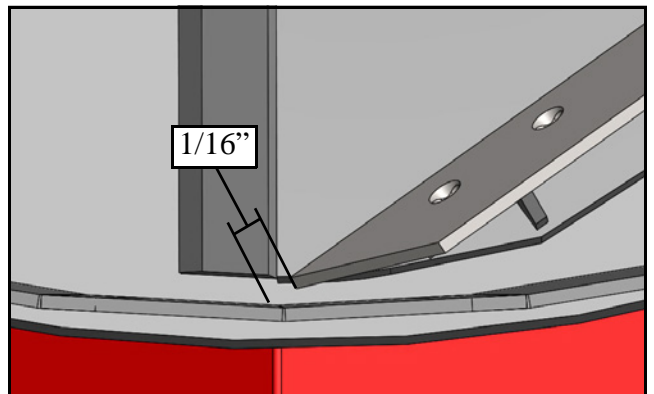

Figure 8.37 Auger Scraper Plate

8.3.6 Auger Timing

Auger timing is critical. Whenever disconnecting the PTO connecting the two planetaries, it is critical that the front leading edge be 225° from the rear leading edge when the rear leading edge is pointing to the front auger.

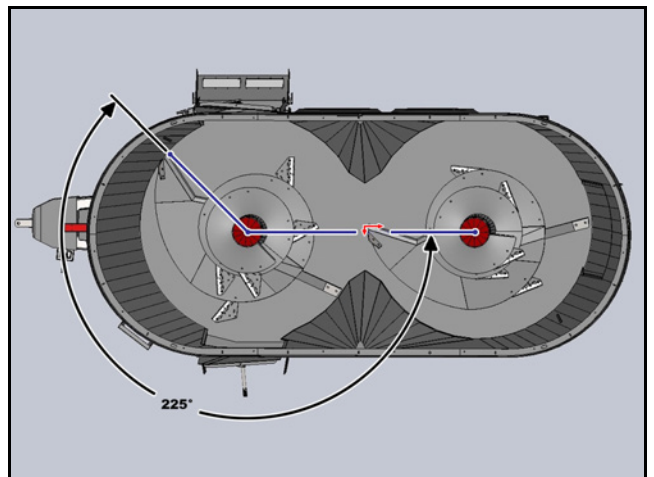

Figure 8.38 Auger Timing

8.3.7 585 & 700 Driveline Alignment

Alignment of the driveline is very important. If the driveline is not properly aligned, a vibration noise could start occurring.

In order to properly align the drive shaft joints:

- Find the split in the yoke on the PTO (Item 1) and the split in the yoke on the Universal Joint (Item 2) before the 2-speed gearbox (Item 3) or planetary.
- These two splits should be installed so that they are in-line with each other as shown in the images below.
- You will notice the bolts holding the joints to the shaft are parallel.
- To adjust remove the bolt on the PTO yoke, adjust to align as shown, and re-tighten the bolt.
- Loosen the bolts that attach the bearing directly in front of the 2-speed gearbox (Item 4). With the bearing loose, rotate the shaft an entire revolution to ensure it doesn't bind. With the shaft rotating freely, tighten the bearing (Item 4) hardware.

NOTE: Mixer needs to be empty in order to rotate input shaft.

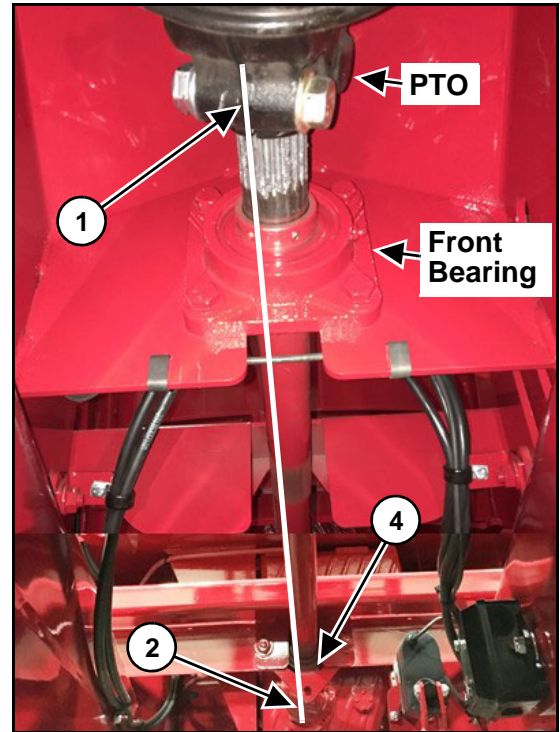

Figure 8.39 585/700 Driveline Alignment

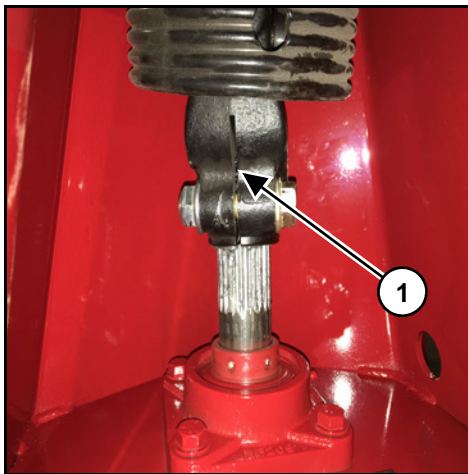

Figure 8.40 Primary PTO Yoke

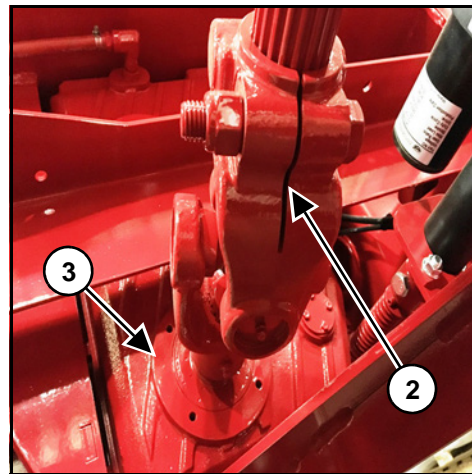

Figure 8.42 Universal Joint Yoke

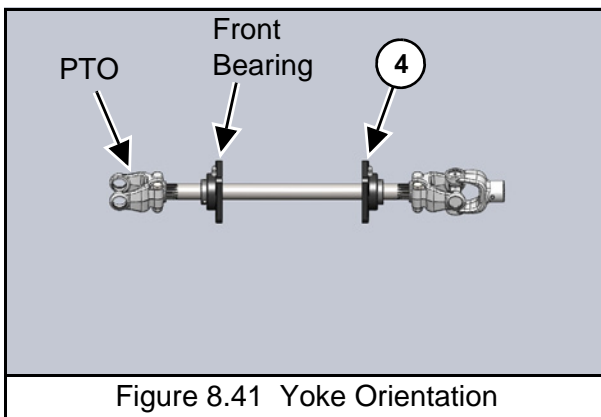

Figure 8.41 Yoke Orientation

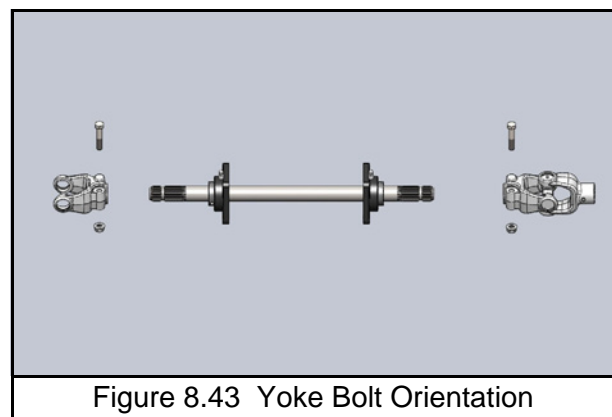
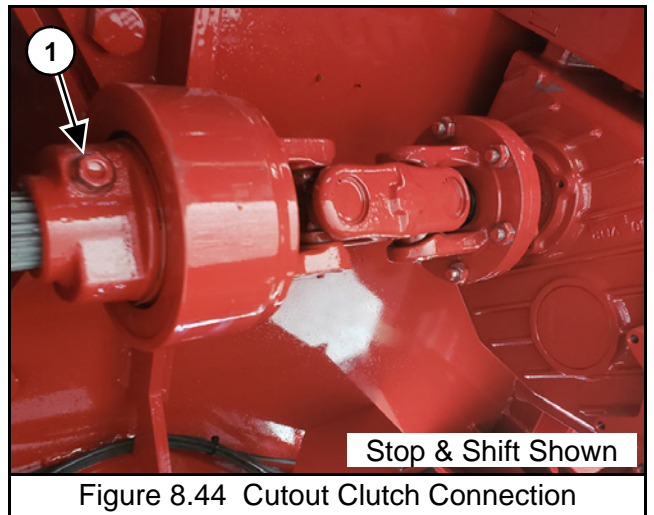

Figure 8.43 Yoke Bolt Orientation

8.3.8 PTO Cutout Clutch Connection

The cutout clutch end of the PTO driveline must always be attached to the implement. The PTO driveline is equipped with a 1-3/4" x 20 spline on the implement half for attaching to the spreader. Remove the M17-hexagon bolt from the splined hub and slide the PTO onto the implement splined input shaft. Install the hexagon bolt (Item 1) through the hub being sure the bolt is falling into the groove on the splined shaft. Torque tight using a metric size M17 6-point socket and torque down to 75 ft. lbs. A M17 6-POINT METRIC SOCKET MUST BE USED AS ROUNDING OF HEXAGON BOLT AND INACCURACY OF TORQUE SETTINGS COULD OCCUR.

If removal of the M-17 hexagon bolt is necessary, use the same M-17 6-point socket and loosen bolt 1/2 turn. Insert a 1/4" drift punch in the hole on the opposite side of the hexagon bolt and tap to loosen the seated portion of the bolt from the splined hub. Loosen in 1/4 turn increments and tapping to loosen. After bolt seat has been released, remove the bolt. If bolt is not unseated, damage to the hexagon bolt will occur.



8.3.9 Knives

Knives are designed and intended for processing and mixing rations that include long stem forages.

NOTE: Some rations may require adding or removing knives, or changing knife position to obtain the desired result.

8.3.9.1 Knife Removal

Individual knives may be removed from the auger if the ration does not include hay or includes very small amounts of small square bale hay or tub ground hay. Removing knives will decrease the aggressive cutting action on the stem length of the ration and may also reduce horsepower requirements.

8.3.9.2 Adding Knives

If the hay in your ration is not being processed enough or fast enough extra knives may be ordered through your dealer. Adding extra knives will help break down and process materials faster, but may increase the horsepower required to process and mix.

8.3.9.3 Knife Placement

The placement of knives towards the bottom of the auger will process the forage faster and make the stem length shorter but may require more horsepower. Placement of knives higher on the auger will assist in breaking up bales faster after initial loading.

8.3.9.4 Knife Position

“Out” Position

When the knives are in the “out” position they tend to move the long stem hay and lighter bulky materials best in the early stages of processing and mixing. This setting may result in feed spillage in certain materials. Knives placed in this setting are very aggressive in processing feed and will also cause an increase in horsepower requirement.

“In” Position

When the knives are in the “in” position they will slow down the long stem hay and lighter bulky materials in the early stages of processing and mixing. Less spillage will occur due to clearance between the knives. This setting is more desirable for heavy rations with long run time and where over processing can occur. Knives placed in this position are less aggressive in processing feed and will reduce the horsepower requirement.

8.3.9.5 Replacing Damaged or Worn Knives

When knives become worn and rounded on the leading edge their efficiency is greatly reduced. This results in longer processing times and increased horsepower requirements. Refer to your parts manual and contact your Meyer MFG dealer for replacement part ordering.

8.3.10 Brake Adjustment (If Equipped)

Properly support wheel end to adjust the brakes with the tire assembly removed.

Excessive actuator travel (over one inch) is a sign that the brakes need to be adjusted. Jack wheel/tire off of the ground and rotate tire in the forward direction. The brake adjustment nut is located through a slot at the bottom of the backing plate. Insert brake tool or screwdriver into slotted hole with handle up and bit against the adjusting wheel, pull down on handle and rotate drum in forward direction while tightening. When you can no longer rotate drum in the forward direction, then loosen the large nut on the back side of the brake cluster, located at the 12 o'clock position, one turn, do not take nut completely off, just loosen to allow anchor pin to realign. Take dead blow hammer and tap on brake drum several times around the perimeter, now re-tighten the large anchor pin nut. Back off adjuster twenty clicks (notches) for two-wheel brake systems and fifteen clicks (notches) for four wheel brake systems, and back off shoe adjuster 10-15 clicks. If there is one spot where the wheel drags just slightly, this is acceptable. As soon as the brake linings are burnished (this requires several braking stops) the brakes will then be set correctly.

8.3.11 Wheel Bearing Preload

1. Chock all four wheels or hitch to tractor with engine off, key removed and parking brake set. Jack empty mixer off ground and support with adequate jack stands.
2. Push back and forth on each wheel assembly. If play is detected, bearings need adjusting.
3. If adjusting bearings, it is suggested the bearings be repacked as described previously.
4. Remove hub cap and remove cotter pin from spindle nut.
5. Tighten spindle nut to remove all play. It should be snug and slight drag can be felt while rotating the wheel.
6. If the cotter pin hole in the spindle does not line up with the notch in spindle nut, back off the spindle nut only enough to line up. Reinstall cotter pin. If cotter pin is damaged, replace it.
7. Replace hub cap and lower wheel to the ground.

8.4 FASTENER TORQUE SPECIFICATIONS



Shutoff and lockout power before adjusting, servicing, maintaining, or clearing an obstruction from this machine. Refer to section 5.3 SHUTOFF & LOCKOUT POWER.

After an initial break in period approximately four months and periodically thereafter, ALL bolts and nuts should be checked to ensure that recommended torque values are being maintained.

8.4.1 General Torque Specifications



DO NOT use these values if a different torque value or tightening procedure is given for a specific application. Torque values listed are for general use only and include a + or - 10% variance. Check tightness of fasteners periodically. DO NOT use air powered wrenches.

Head Marking	Grade and Material	Nominal Size Range (inches)
 No Markings	Grade 2 Low or medium carbon steel	1/4" thru 3/4" Over 3/4" thru 1-1/2"
 3 Radial Lines	Grade 5 Medium carbon steel, quenched and tempered	1/4" thru 1" Over 1" thru 1-1/2"
 6 Radial Lines	Grade 8 Medium carbon alloy steel, quenched and tempered	1/4" thru 1-1/2"
 A325	Grade A325 Carbon or Alloy Steel with or without Boron	1/2" thru 1-1/2"
Stainless markings vary. Most stainless is non-magnetic	18-8 Stainless Steel alloy with 17-19% Chromium and 8-13% Nickel	All Sizes thru 1"

Figure 8.46 SAE Bolt Grade

Head Marking	Class and Material	Nominal Size Range (mm)
 8.8	Class 8.8 Medium carbon steel, quenched and tempered	All Sizes below 16mm 16mm - 72mm
 10.9	Class 10.9 Alloy steel, quenched and tempered	5mm - 100mm
 12.9	Class 12.9 Alloy steel, quenched and tempered	1.6mm - 100mm
Stainless markings vary. Most stainless is non-magnetic. Usually stamped A-2.	A-2 Stainless Steel alloy with 17- 19% chromium and 8-13% nickel	All Sizes thru 20mm

Figure 8.45 Metric Bolt Grade

SAE				
	Grade 5, 5.1 & 5.2		Grade 8 & 8.2	
Size (inches)	Lubricated (lb-ft)	Dry (lb-ft)	Lubricated (lb-ft)	Dry (lb-ft)
1/4	7	9	10	12.5
5/16	15	18	21	26
3/8	26	33	36	46
7/16	41	52	58	75
1/2	63	80	90	115
9/16	90	115	130	160
5/8	125	160	160	225
3/4	225	280	310	400
7/8	360	450	500	650
1	540	675	750	975
1-1/8	675	850	1075	1350
1-1/4	950	1200	1500	1950
1-3/8	1250	1550	2000	2550
1-1/2	1650	2100	2650	3350

METRIC								
	Class 4.8		Class 8.8 & 9.8		Class 10.9		Class 12.9	
Size (mm)	Lubricated (lb-ft)	Dry (lb-ft)	Lubricated (lb-ft)	Dry (lb-ft)	Lubricated (lb-ft)	Dry (lb-ft)	Lubricated (lb-ft)	Dry (lb-ft)
M6	3.5	4.5	6.5	8.5	9.5	12	11.5	14.5
M8	8.5	11	16	20	24	30	28	35
M10	17	21	32	40	47	60	55	70
M12	29	37	55	70	80	105	95	120
M14	47	60	88	110	130	165	150	109
M16	73	92	140	175	200	225	240	300
M18	100	125	195	250	275	350	325	410
M20	140	180	275	350	400	500	460	580
M22	190	250	375	475	540	675	625	800
M24	250	310	475	600	675	850	800	1000
M27	360	450	700	875	1000	1250	1150	1500
M30	490	625	950	1200	1350	1700	1600	2000
M33	675	850	1300	1650	1850	2350	2150	2750
M36	850	1075	1650	2100	2350	3000	2750	3500

8.4.2 Wheel Torque

BOLT/STUD SIZE	SOCKET SIZE	PRESS FORMED WHEEL CENTER	BOLT TYPE	HEAVY DUTY WHEEL CENTER
3/4"	1-1/8" / 1-1/2"	N/A	Flange Nut	378 lb-ft
5/8"	15/16" / 1-1/16"	100 lb-ft	Bevel or Flange Nut	160 lb-ft

8.4.3 Hub Torque

1. Torque the spindle nut while rotating the hub to seat the bearings using the Seat Bearings torque value for your specific hub listed in the table below.
2. Loosen spindle nut.
3. Re-torque the spindle nut to the Final Torque.
4. Install cotter pin. If the nut isn't aligned with the cotter pin hole, back the nut off to closest position that does. **Do Not** back the nut off more than 30° from Final Torque position.

MEYER PART #	MODELS	SEAT BEARINGS	FINAL TORQUE
75-0209	585/700	80 lb-ft	50 lb-ft
75-0222	F2-585/F2-700		

8.5 ELECTRICAL

8.5.1 Power Shift Remote Control Programming

1. Apply a temporary 12 Volt positive (Key 1) and negative (Key 2) source to the receiver.
2. Locate the push button labeled "PROGRAM" on the receiver. Press and hold this button until the red LED next to the program button illuminates (approximately 3 seconds). The receiver is now in the remote program mode. Release the button. At this point all previously programmed remotes are erased from the receiver's memory.

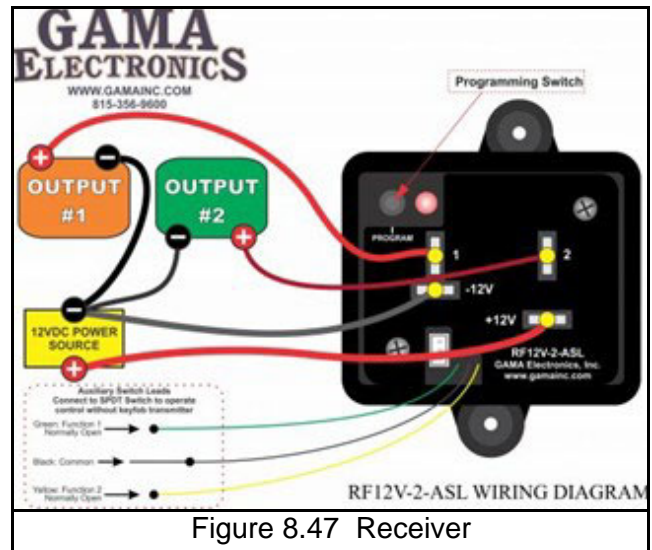

3. **Single Remote:** Press and release either button on the remote once and verify that the red program LED extinguishes and blinks once.

Multiple Remotes: For the first remote being programmed press and release either button once, then once on the second remote, once on the third remote, once on the fourth remote etc. The receiver will not respond to remotes that have been previously programmed. The first remote that is programmed determines the receiver's relay operating mode.

4. The receiver will return to normal mode if no remote buttons are pressed for 5-seconds. The red LED on the receiver will blink rapidly, then extinguish. The receiver is now in the normal mode of operation. Test remote by pressing either button. The red program LED on the receiver should stay on until the button on the remote is released.
5. This completes the programming instructions. The receiver will retain its programming even when power is removed.
6. Remove the temporary 12 Volt positive (Key 1) and negative (Key 2) source to the receiver.



8.5.1.1 Remote Troubleshooting

If your RF remote control system does not work out of the box, stops working or functions intermittently please take the following steps to resolve common issues. Please note that you must be 2-3 feet away from the receiver when operating the transmitter. Operating within 2-3 feet may result in no operation or intermittent operation.

1. Recharge your remote.
 - The remote can activate during shipping and drain the battery.
 - The remote can be charged using a micro USB cable and any standard USB outlet or charger. Plug the micro USB into the connector located on the bottom of the remote.

NOTE: When the transmitter is plugged into a USB outlet/charger the LED backlights will slowly fade on and then fade off while the unit is charging. Once the transmitter has reached a full charge, the LEDs will extinguish and remain off.

2. Check the voltage supply at the receiver.
 - The receiver is designed to function at 10VDC-15VDC. Voltage on the (+) and (-) terminals on the control should be within this range.
3. Reprogram the remote.
 - If the system is non-functional, try to reprogram the remote. The program may not have taken during the programming process, or the program button may have been pressed. If the program button is pressed the memory of the remote(s) programed to the receiver are erased.
4. Listen and look for functionality on the receiver.
 - The LED that is used for programming the system will illuminate when the receiver is activated. You will also hear a “click” when the internal relays engage. If you can see the LED illuminate and you hear the relay “click” the issue is most likely in the wiring or device being controlled.

8.5.2 Digital Scale Indicator

Refer to scale indicator (Item 1) manufacturer’s operators manual for maintenance.

NOTE: Some scale drift may occur after the scale is turned on but should level out within 10 to 15 minutes. Temperature changes may also cause some drifting.

JUNCTION BOX WIRING						
	FUNCTION	WEIGH BAR WIRING			MONITOR WIRING	
		DIGISTAR	WEIGH-TRONIX	DYNAMICA GENERALE	STANDARD	WEIGH-TRONIX*
1	+SIG	WHITE	WHITE	GREEN	WHITE	WHITE
2	-SIG	GREEN	RED	WHITE	GREEN	RED
3	+EX	RED	GREEN	RED	RED	GREEN
4	-EX	BLACK	BLACK	BLACK	BLACK	BLACK
5	SHIELD	TRANSP	ORANGE	BLUE	TRANSP	TRANSP

*WEIGH-TRONIX MONITOR WITH WEIGH-TRONIX WEIGH BARS ONLY 46-0001-199 2

Figure 8.49 Weigh Bar Wiring Diagram

Scale Set Up Numbers

Digistar Monitors	
SET UP #	CALIBRATION #
126080	36909

Weigh-Tronix Monitors	
CONFIGURE #	CUSTOM #
98300	35910

8.6 WHEELS AND TIRES

8.6.1 Wheel Installation



These instructions are not complete. Read and follow all procedures in user's guide to wheels and rims by "The Maintenance Council" #T0410. If you have questions call Walther Eng. & Mfg. company inc. (937) 743-8125.

- Clean adjoining surfaces.
- Start nuts to bring wheel and brake drum (If Equipped) flush to hub mounting surface.
- Avoid brake drum (If Equipped) and/or wheel binding on hub.
- Install remaining wheel nuts. Torque to 50 ft-lbs, then re-torque to required full torque (See 8.4.2 Wheel Torque).
- Re-torque wheel nuts after 50-100 miles.
- Check wheel nut torque every 10,000 miles and re-torque as necessary.

8.6.2 Tire Inflation

TIRE SIZE	PSI
385/65R x 22.5	100
245/70R x 19.5	100
380/60R x 16.5	73
380/55R x 16.5	73
435/50 x 19.5	100
12.5L-15	52

If tires are to operate for any length of time on roads or other hard surfaces and the draft load is not great, it is advisable to increase the pressure in the tire to the maximum recommendation in order to reduce the movement of the tread bars that causes excessive wiping action.

Inflation pressures should be checked at least every week. Recommended inflation pressures based on total load on tires should be used. For accurate inflation use a special low-pressure gauge with one-pound gradations. Gauges should be checked occasionally for accuracy. Always use sealing valve caps to prevent loss of air.

8.6.3 Implement Tires

Agricultural tires are designed to carry a specified load at a specified inflation pressure when mounted on a specified width rim. When these conditions are met, the deflection of the tire carcass is in the optimum range and maximum tire performance can be expected. If this combination of design factors is altered for any reason, tire performance will be reduced.

Tire Overload or Under Inflation

Tire overload or under inflation have the same effect of over-deflecting the tire. Under such conditions the tread on the tire will wear rapidly and unevenly, particularly in the shoulder area. Radial cracking in the upper sidewall area will be a problem. With under inflated drive tires in high torque applications sidewall buckles will develop leading to carcass breaks in the sidewall. While an under inflated drive tire may pull better in some soil conditions, this is not generally true and not worth the high risk of tire damage that such an operation invites.

Over Inflation

Over inflation results in an under-deflected tire carcass. The tread is more rounded, concentrates tread wear at the centerline area. Traction is reduced in high torque service because ground contact of the tread shoulder area is reduced and the harder carcass, with reduced flexing characteristics, does not work as efficiently. The tightly stretched overinflated carcass is more subject to weather checking and impact break damage.

Pressure Adjustments Required - Slow Speed Operation

Higher tire loads are approved for intermittent service operations at reduced speed. Under such conditions inflation pressure must be increased to reduce tire deflection and assure full tire service life. See 8.6.2 Tire Inflation for proper inflation.

Use of Proper Width Rims

If tires are mounted on rims of incorrect width, the following conditions can result:

- Use of a wider rim results in flattening of the tread face. This feature may improve traction in loose soil conditions. In hard soils, however, the flatter tread penetrates less effectively and tractive effort is reduced. Additional stresses concentrated in the shoulder area tend to increase the rate of shoulder tread wear. By spacing the tire beads farther apart the sidewalls are forced to flex in an area lower than normal and this can result in circumferential carcass breaks and/or separation.
- Use of a narrower rim brings potential mounting problems because the rim shield or flange cover molded into most drive tire designs tends to interfere with the seating of the tire beads on a narrow rim. Once mounted on a narrow rim, the tire shield applies undue pressure on the rim flange, with possible tire sidewall separation or premature rim failure at the heel radius. On a narrow rim the tread of the tire is rounded. As with the over-inflated tire tread wear will be concentrated in the center area of the tread and traction in the field will be reduced.

Roading Of Farm Implement Tires

- Tractor tires operate most of the time in field conditions where the lugs can penetrate the soil, and where all portions of the tread make contact with the ground. In operating on hard roads with low inflation pressure there is an undesirable distortion of the tire during which the tread bars squirm excessively while going under and coming out from under the load. On highly abrasive or hard surfaces, this action wipes off the rubber of the tread bars or lugs and wears them down prematurely and irregularly.
- Farm tractor and implement tires are designed for low-speed operations not exceeding 25 miles per hour. If tractors or implements are towed at high speeds on the highway high temperatures may develop under the tread bars and weaken the rubber material and cord fabric. There may be no visible evidence of damage at the time. Later a premature failure occurs which experience shows was started by the overheated condition that developed when the unit was towed at a high speed.

Care And Storage Of Tractor And Implement Tires

- All tires should be stored indoors in a cool, dark, dry area free from drafts. Both heat and light are sources of oxidation on the tire surfaces - a result of which is crazing and weather checking. Tires should never be stored on oily floors or otherwise in contact with solvents, oil or grease. Further, tires should not be stored in the same area with volatile solvents. Such solvents are readily absorbed by rubber and will damage and weaken it.
- Tires should be stored away from electric motors, generators, arc welders, etc. since these are active sources of ozone. Ozone attacks rubber - to cause crazing and weather checking.
- Unmounted tires should be stored vertically on tread. If stored for an extended period, tires should be rotated periodically to reduce stress concentrations in the area of ground contact. Tires should not be stored flat and "stove piped" as they will become squashed and distorted, making mounting on the rim difficult - particularly for tubeless tires.
- Inflated tires mounted on rims should be stored under conditions noted above, with inflation pressure reduced to 10 PSI.

8.7 STORING THE IMPLEMENT

LOCKOUT / TAGOUT the machine / mixer. (See 5.3 SHUTOFF & LOCKOUT POWER)

Extended Storage

Sometimes it may be necessary to store your Meyer mixer for an extended period of time. Below is a list of items to perform before storage.

- Fully empty the material from the mixer. (See 7.6 UNLOADING)
- Thoroughly clean the mixer inside and outside.
- Remove all material build-up.
- Lubricate the equipment. (See 8.2 LUBRICATION)
- Inspect all mixer components for wear or damage. Repair and replace components as necessary.
- Make appropriate adjustments to equipment. (See 8.3 ADJUSTMENTS)
- Place hydraulic hoses and 7-pin connector in the storage brackets (if equipped).
- Inspect the hitch and all welds on the equipment for wear and damage.
- Check for loose hardware, missing guards, or damaged parts.
- Check for damaged or missing safety signs (decals). Replace if necessary.
- Touch up all paint nicks and scratches to prevent rusting.
- Place the equipment in a dry protected shelter.
- Place the equipment flat on the ground.

8.8 RETURN THE IMPLEMENT TO SERVICE

After the Meyer mixer has been in storage, it is necessary to follow a list of items to return the equipment to service.

- Be sure all shields and guards are in place.
- Lubricate the equipment.
- Check tire pressure and that the lug nuts are tight.
- Connect to a tractor and operate equipment; verify all functions operate correctly.
- Check for leaks. Repair as needed.

8.9 MIXER TROUBLESHOOTING GUIDE

PROBLEM	POSSIBLE SOLUTIONS
Requiring High Horsepower	<ul style="list-style-type: none"> • Reduce load size. • Adjust hay stops to a less aggressive or neutral position. • The load size may need to be reduced until the unit is polished inside. • Modify the knife type, quantity, setting, or placement. • Shift mixer into “Low”.
Digital Scale Indicator	<ul style="list-style-type: none"> • Refer to scale manufacturer’s operator manual for operation and maintenance. • Some scale drift may occur after the scale is turned on but should level out within 10 to 15 minutes. • Temperature changes may also cause some drifting.
Planetary Reservoir Is Overflowing or Stop & Shift Reservoir Is Overflowing (If Equipped)	<ul style="list-style-type: none"> • Check oil level when cold. • Clean breather. • Make sure hoses are not kinked or clogged. • Change oil.
Cooling Light Fault Indicated	<ul style="list-style-type: none"> • Check to make sure there is no debris preventing cooling fans from running. • Clean radiators. • Check electrical connections and wiring. • Check for faulty fan motors. Replace if necessary.



9.0 REPAIR PARTS

WARNING

Before servicing this equipment, ensure that all personnel, including family members are familiar with the equipment and the safety hazards that are present, along with the safety practices that should be observed while working in this equipment.

CAUTION

Inspect the axles, o-beams, spindles, tires, hitches and all safety shielding, safety signs and safety lighting regularly. These parts if not watched closely, could pose potential injury or death. If any part is found in need of repair, follow the SHUTOFF & LOCKOUT POWER recommendations and have qualified personnel repair immediately.

CAUTION

Shutoff and lockout power before adjusting, servicing, maintaining, or clearing an obstruction from this machine. Refer to section 5.3 SHUTOFF & LOCKOUT POWER.

IMPORTANT

It is important that everyone who works on this equipment is properly trained to help ensure that they are familiar with this procedure and that they follow the steps outlined above. This manual will remind you when to SHUTOFF & LOCKOUT POWER.

At times, parts on this implement will become worn or damaged. Performing repairs on this implement can pose a risk of injury including death. To reduce risk, the party that will be doing the repair should be very knowledgeable of the implement and the equipment that they will be using to do the repair.

- Review the repair so that a plan can be put together and the proper equipment can be used to repair this implement safely and correctly.
- Personal safety equipment may include items such as safety glasses, protective footwear, hearing protection, gloves, fire retardant clothes, etc.

WARNING

Crushing Hazard:
Do Not work under suspended or blocked parts



- The use of hoists and/or supports may be needed to handle heavy components.
- If the implement is being repaired in the field, make sure the parking brake of the tractor is engaged, the implement is on solid and level ground.
- Welding and torching should be done by properly trained individuals who have proven their skills.

IMPORTANT

Call the factory for any additional details you may need to perform the repair. Some parts may come with instruction sheets to assist in the repair. Instruction sheets may be provided with the parts order. Otherwise, if available, instruction sheets can be e-mailed or faxed for your convenience. Call Meyer Manufacturing Corporation toll free at 1-800-325-9103 or email parts@meyermfg.com.

NOTE: Be environmentally friendly and dispose of any waste materials properly. Recycle when appropriate.

585 & 700 LIGHTS

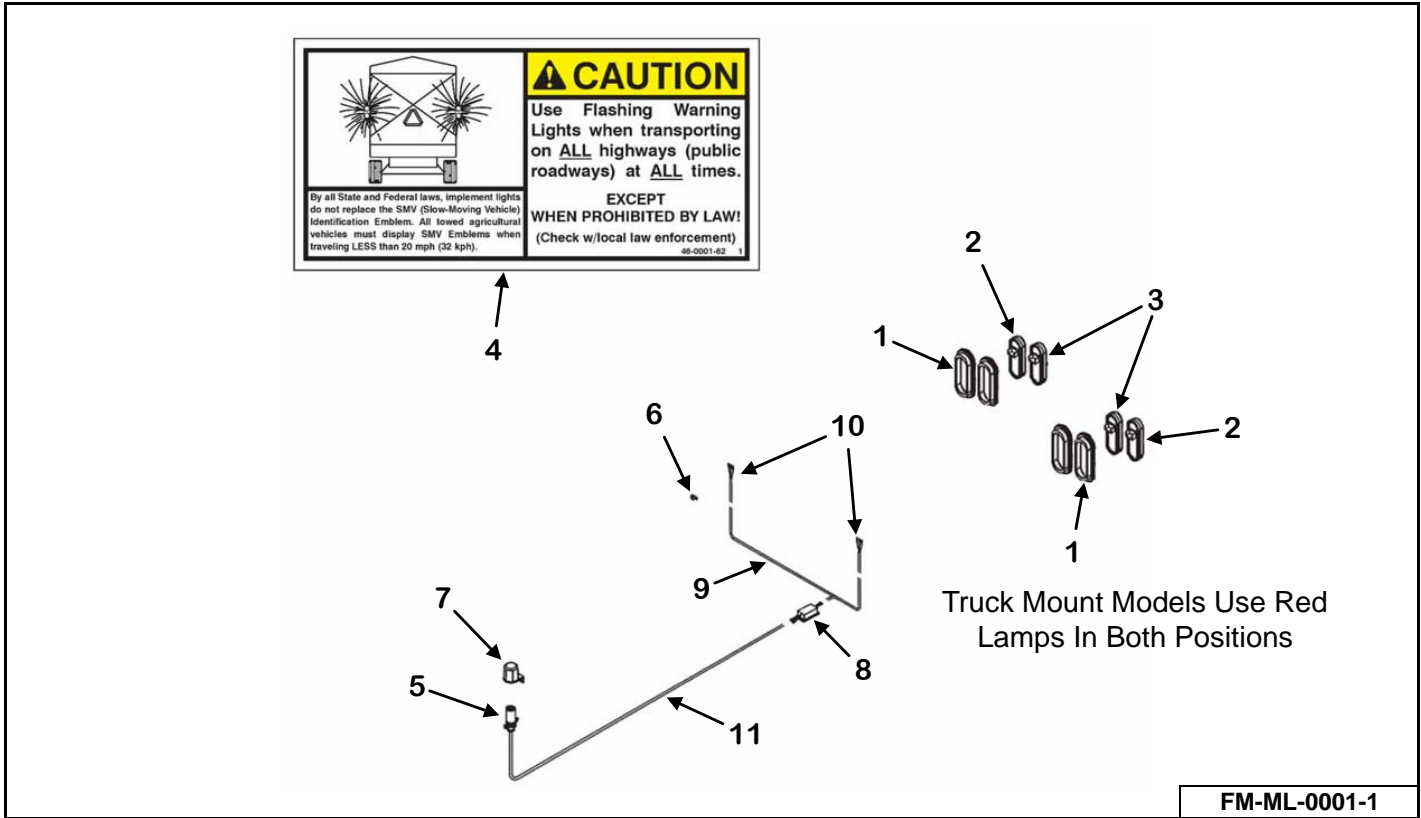

KEY	PART NUMBER	QTY	DESCRIPTION	MIXER MODEL
1	56-0082	4	6" Oval Grommet	585/700
2	56-0081	2/0	6" Oval Amber LED Light	585/700
3	56-0115	2/4	6" Oval Red LED Light	585/700
4	46-0001-62	1	Caution Tail Light Decal	585/700
5	56-0005-2	1	7-Contact Plug End Only	585/700
6	56-0008	2	Harness Frame Clip	585/700
7	56-0009	1	7-Way "Stor-A-Way" Plug Holder	585/700
8	56-0084	1	LED Ag Enhancer Module (Trailer Mounts Only)	585/700
9	56-0130-1	1	Y-Harness Less Light Plug Leads	585/700
10	56-0130-2	2	Right/Left Light Pigtail Lead	585/700
11	56-0211	1	Front Discharge 24' LED Light Cord 6-Pin & 7-Pin Connector	585/700
	56-0212	1	Side Discharge 20.75' LED Light Cord 6-Pin & 7-Pin Connector	585/700

F2-585 & F2-700 LIGHTS

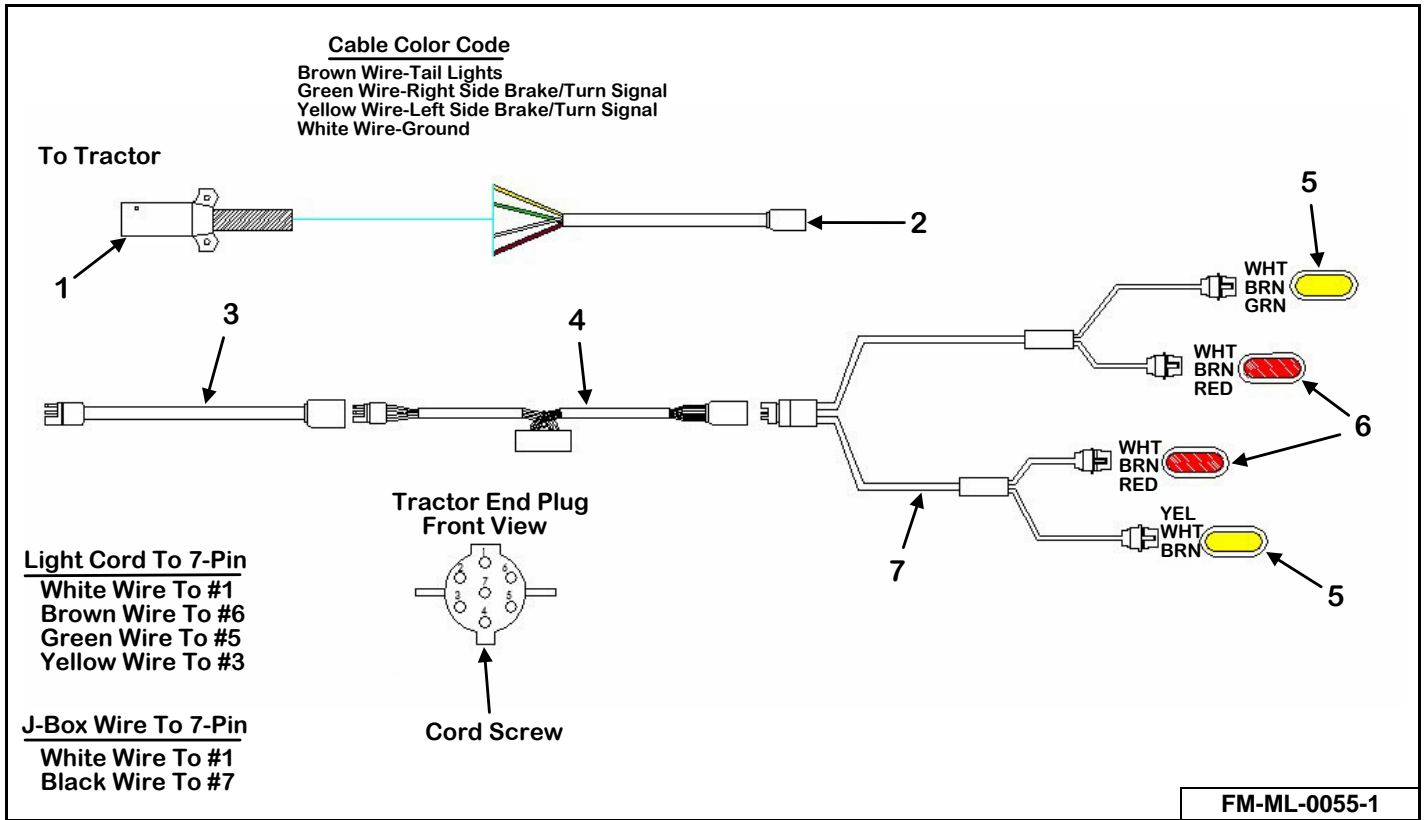

KEY	PART NUMBER	QTY	DESCRIPTION	MIXER MODEL
1	56-0005-4	1	7-Way Plug With Spring	F2-585/F2-700
2	56-0306	1	Maxi-Seal Front Harness to 7-Pin	F2-585/F2-700
3	56-0309	1	198" Maxi-Seal Harness Power Extension (Side Discharge)	F2-585/F2-700
	56-0308	1	222" Maxi-Seal Harness Power Extension (Front Discharge)	F2-585/F2-700
4	56-0284	1	Maxi-Seal Ag Module	F2-585/F2-700
5	56-0081-AMP	2	6-1/2" Amber Clearance Light	F2-585/F2-700
	56-0082	2	6-1/2" Oval Grommet	F2-585/F2-700
6	56-0115-AMP	2	6-1/2" Red Clearance Light	F2-585/F2-700
	56-0082	2	6-1/2" Oval Grommet	F2-585/F2-700
7	56-0310	1	Maxi-Seal Rear Harness	F2-585/F2-700

WEIGH BAR WIRING DIAGRAM

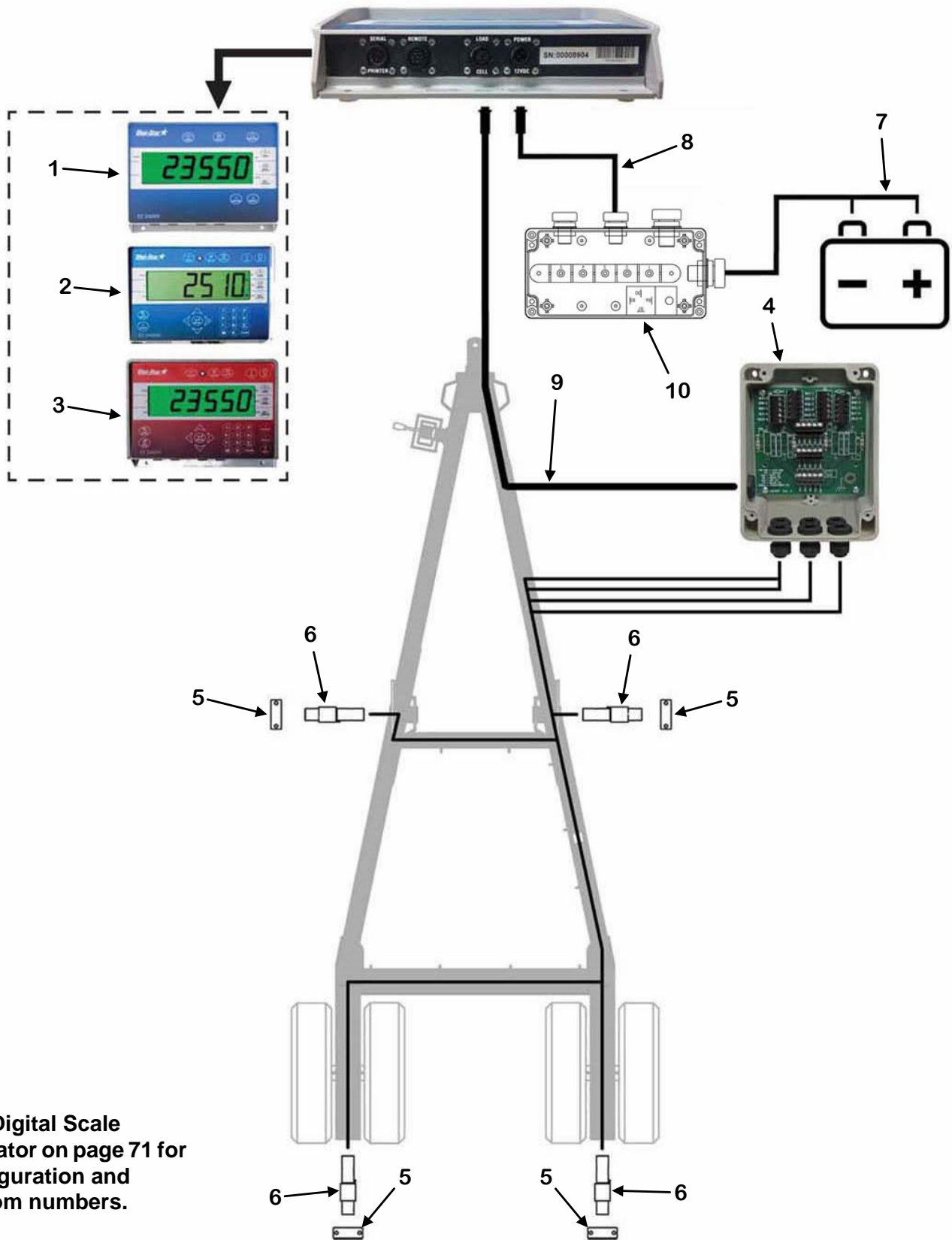

See Digital Scale Indicator on page 71 for configuration and custom numbers.

FM-ML-0002-1

KEY	PART NUMBER	QTY	DESCRIPTION	MIXER MODEL
1	58-0002-1057170-01	1	EZ2805 Scale Indicator Monitor	All Models
	58-0002-281047	1	EZ2810 Scale Indicator Monitor	All Models
2	58-0002-341047	1	EZ3410 Scale Indicator Monitor	All Models
3	58-0002-361023	1	EZ3610 Scale Indicator Monitor	All Models
4	58-0020	1	6 Point Mobil J-Box	All Models
	58-0008	1	6 Point Mobil J-Box With Monitor Cable	All Models
5	M9-1-8-0001	4	DB Bar Mount	All Models
	881-7510-2.5Z	8	3/4"-10 x 2-1/2" Bolt	All Models
6	58-0034-WT	4	2.875" x 14" Load Cell	All Models
7	See Page 82	1	585 & 700 Power Cord Assembly	585/700
	See Page 84		F2 Stop & Shift Power Cord Assembly	F2-585/F2-700
	See Page 86	1	F2 Power Shift Power Cord Assembly	F2-585/F2-700
8	58-0035-10	1	10' Power Cord	All Models
9	58-0029	1	Junction Box To Monitor Cable 30'	All Models
10	See Page 82	1	7-Terminal Enclosure Mixer	585/700
	See Page 84	1	F2 Stop & Shift Junction Box Assembly	F2-585/F2-700
	See Page 86	1	F2 Power Shift Junction Box Assembly	F2-585/F2-700
NS	58-0002-410002	1	Pack RPM Sensor (No Extension Cable)	All Models
NS	58-0002-408845	1	RPM Y-Alarm Cord	All Models
NS	58-0002-SPC-1	1	8' Printer/Computer Connector Lead	All Models
NS	58-0002-SPC-3	1	24' Printer/Computer Connector Lead	All Models
NS	58-0038-2-1	1	Sensor RPM With Connector 6'	All Models

KEY	PART NUMBER	QTY	DESCRIPTION	MIXER MODEL
1	56-0202	1	Proximity Switch Assembly	585/700
1A	56-0200-1	1	Proximity Switch	585/700
2	56-0205	1	5-Wire Tractor to Junction Power Cord	585/700
3	56-0204	1	2-Speed Power Cord Assembly	585/700
	56-0136	1	3-Pin Aux Power Cord Assembly (Optional)	585/700
	VA-BBL	1	Battery Box Package (Optional)	585/700
	656-0001-2	1	10 Amp 250V Fuse	585/700
4	56-0280	1	7-Terminal Enclosure	585/700
	56-0200-3	1	Normally Open Relay	585/700
5	56-0224	1	2-Speed Actuator Power Cord, Front Discharge	585/700
	56-0225	1	2-Speed Actuator Power Cord, Side Discharge	585/700
6	56-0123	1	12V Linear Actuator With Plug	585/700
7	56-0282	1	2-Speed Control Box ASM	585/700

F2 STOP & SHIFT ELECTRICAL SYSTEM

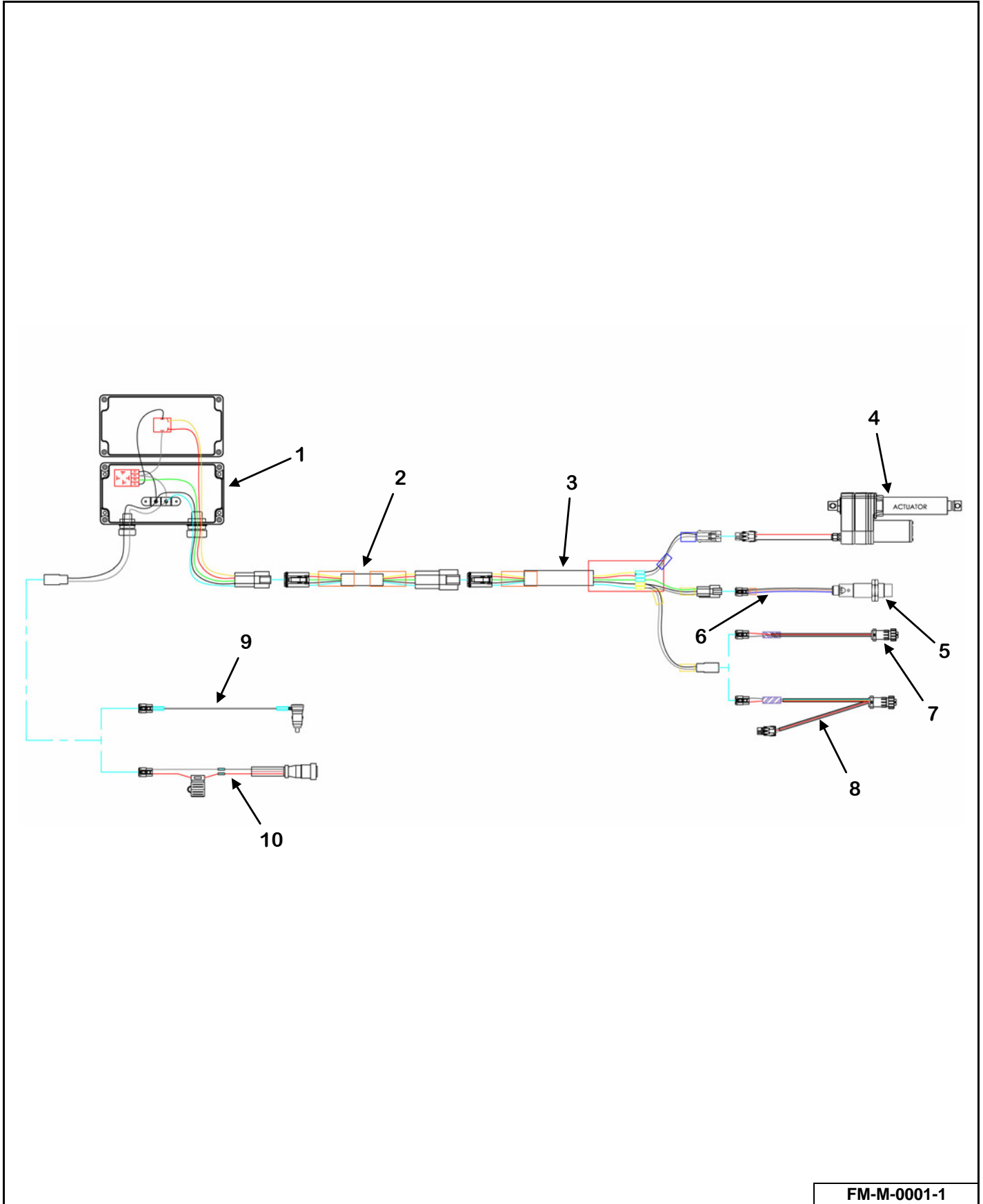

FM-M-0001-1

KEY	PART NUMBER	QTY	DESCRIPTION	MIXER MODEL
1	See Page 88	1	Junction Box Assembly	F2-585/F2-700
2	56-0536	1	Extension Harness	F2-585/F2-700
3	56-0533	1	Chassis Harness	F2-585/F2-700
4	56-0123	1	12V Actuator	F2-585/F2-700
5	56-0393	1	Programmed Sensor	F2-585/F2-700
6	56-0505	1	Power Extension Harness	F2-585/F2-700
7	56-0527	1	Monitor Cord Harness (Optional Monitor Package)	F2-585/F2-700
8	56-0528	1	Monitor Cord Harness With Rotational Counter (Optional Monitor Package)	F2-585/F2-700
9	56-0525	1	12V Power Harness	F2-585/F2-700
10	56-0526	1	3-Pin Power Harness	F2-585/F2-700

F2 POWER SHIFT ELECTRICAL SYSTEM

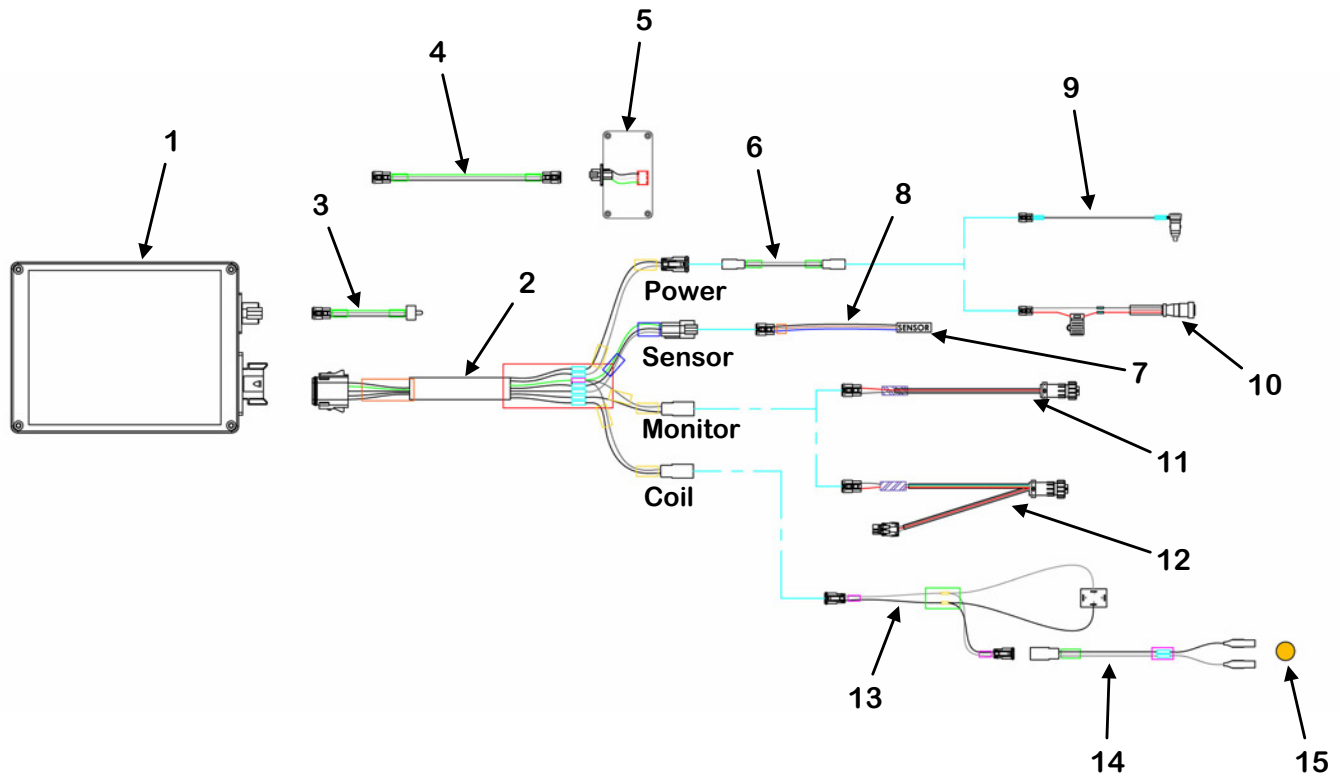

FM-M-0002-1

KEY	PART NUMBER	QTY	DESCRIPTION	MIXER MODEL
1	See Page 89	1	Junction Box Assembly	F2-585/F2-700
2	56-0521	1	Chassis Harness	F2-585/F2-700
3	56-0531	1	Manual Switch Harness	F2-585/F2-700
4	56-0530	1	Manual Switch Extension Harness (Optional)	F2-585/F2-700
5	56-0529	1	Manual Switch Control Box (Optional)	F2-585/F2-700
6	56-0524	1	Power Extension Harness	F2-585/F2-700
7	56-0389	1	Programmed Sensor	F2-585/F2-700
8	56-0505	1	Power Extension Harness	F2-585/F2-700
9	56-0525	1	12V Power Harness	F2-585/F2-700
10	56-0526	1	3-Pin Power Harness	F2-585/F2-700
11	56-0527	1	Monitor Cord Harness (Optional Monitor Package)	F2-585/F2-700
12	56-0528	1	Monitor Cord Harness With Rotational Counter (Optional Monitor Package)	F2-585/F2-700
13	56-0522	1	Coil Harness	F2-585/F2-700
14	56-0523	1	Indicator Harness	F2-585/F2-700
15	56-0111-BT	1	Amber Light	F2-585/F2-700

F2 STOP & SHIFT JUNCTION BOX

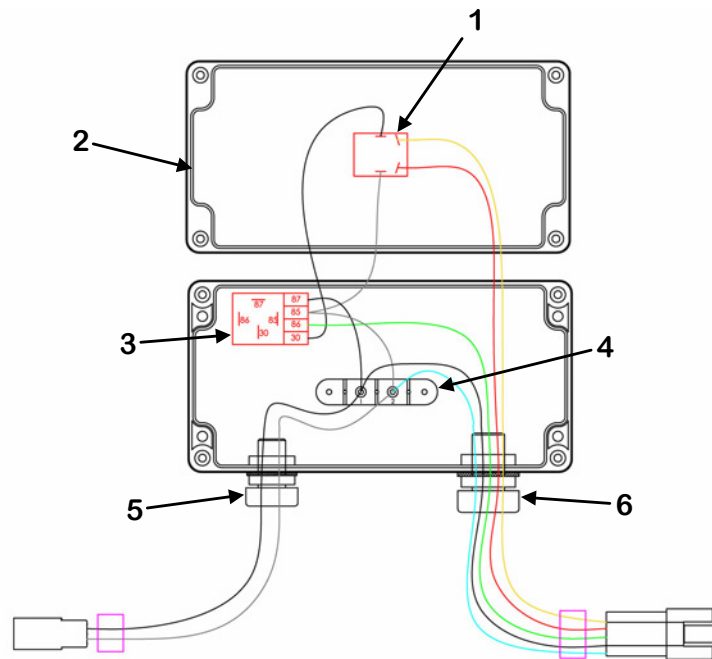

56-0532

KEY	PART NUMBER	QTY	DESCRIPTION	MIXER MODEL
0	56-0532	1	Junction Box Assembly	F2-585/F2-700
1	56-0200-4	1	Toggle Switch	F2-585/F2-700
	55-0303-3	1	Toggle Switch Boot	F2-585/F2-700
2	46-M-0026	1	Cover Decal	F2-585/F2-700
3	56-0200-3	2	70A Relay	F2-585/F2-700
4	56-0532-2	1	2-Pin Terminal Block	F2-585/F2-700
5	156-CG-06-1	1	Cord Grip	F2-585/F2-700
6	156-CG-08-1	1	Cord Grip	F2-585/F2-700

F2 POWER SHIFT JUNCTION BOX

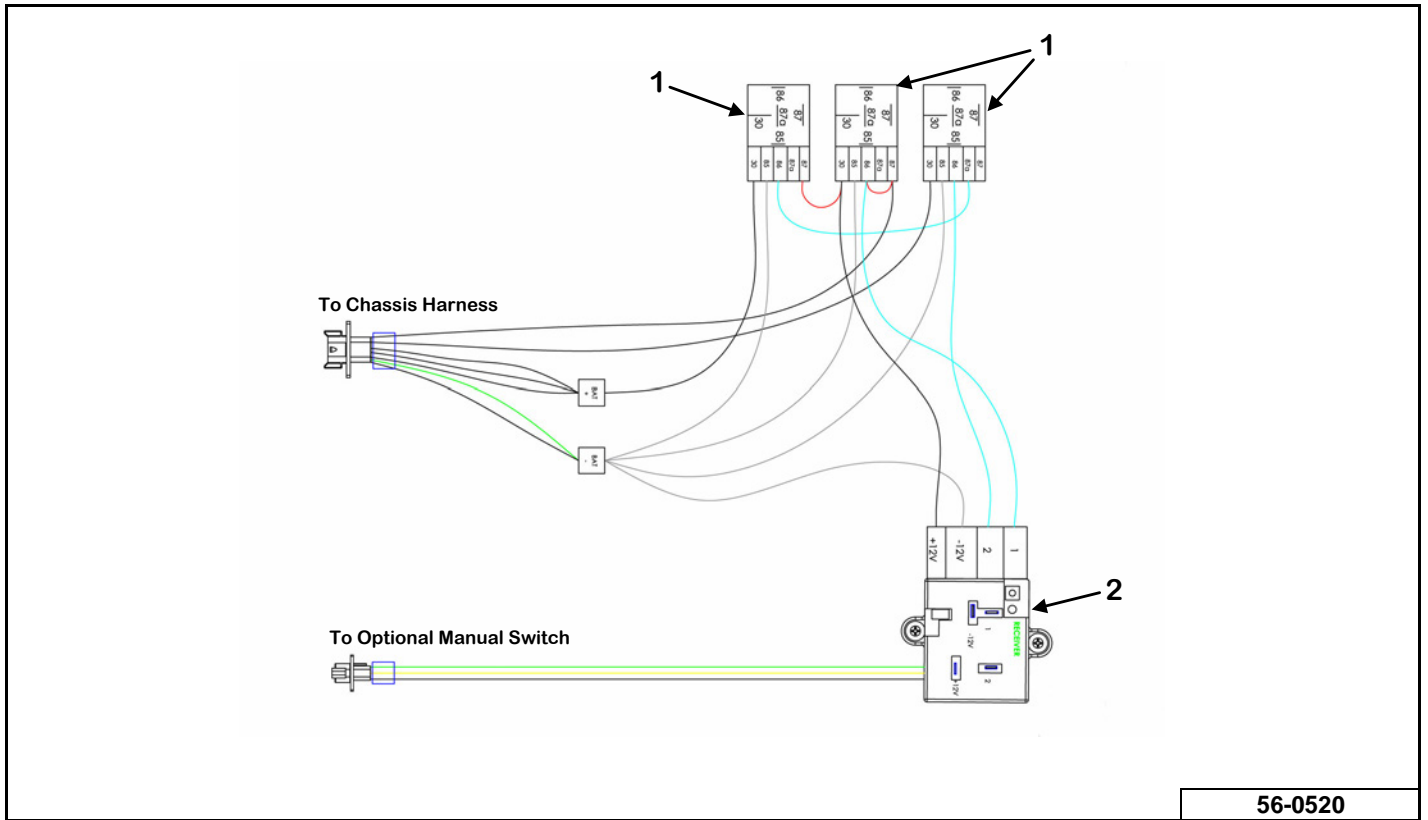

KEY	PART NUMBER	QTY	DESCRIPTION	MIXER MODEL
0	56-0520	1	Junction Box Assembly	F2-585/F2-700
1	56-0501-2	3	50A Relay	F2-585/F2-700
	56-0501-1	3	Relay Housing	F2-585/F2-700
2	56-0350	1	Remote Control Receiver Assembly	F2-585/F2-700

SINGLE AXLE TRAILER

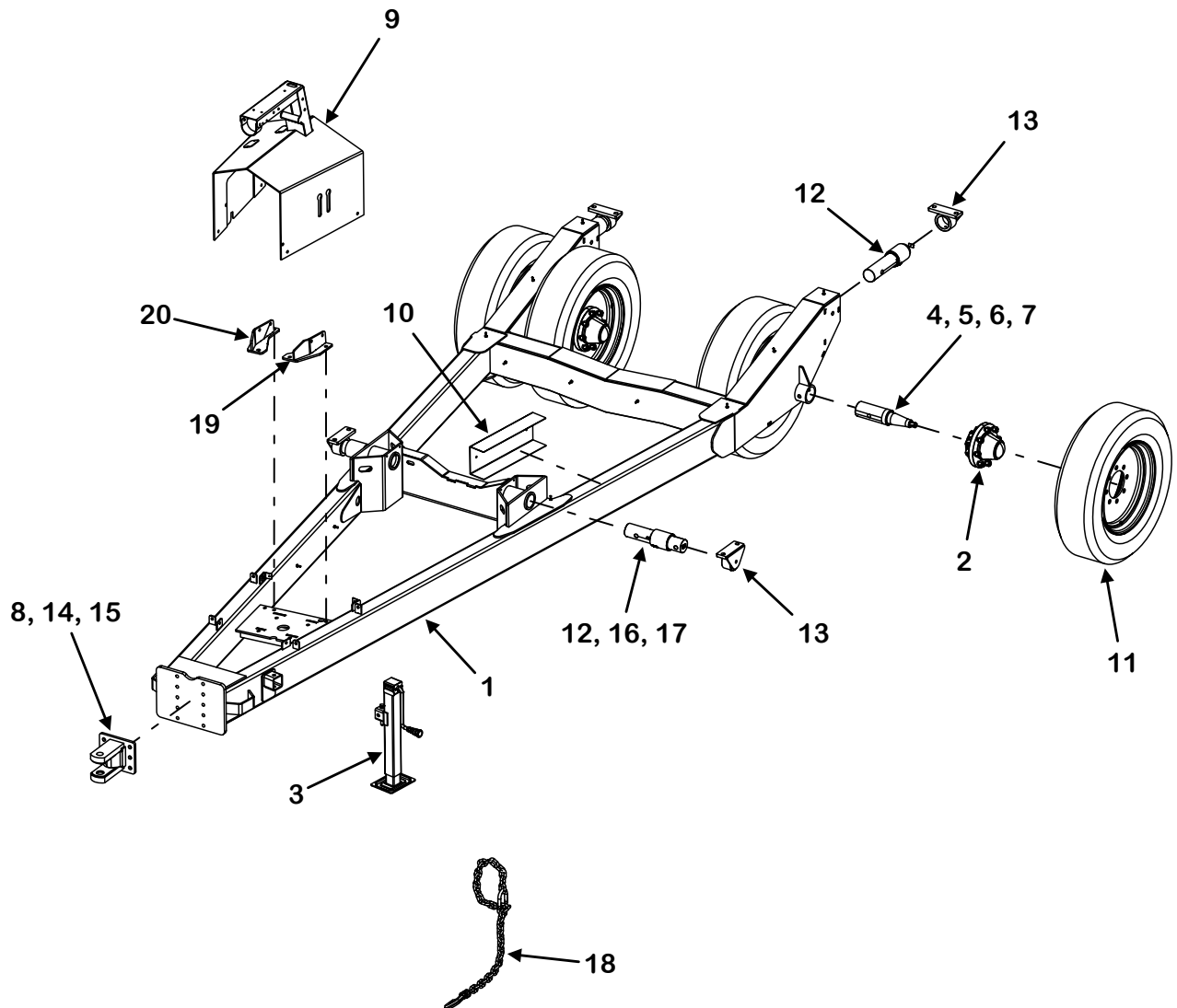

FM-M-0003-1

KEY	PART NUMBER	QTY	DESCRIPTION	MIXER MODEL
1	M1-7-0007	1	Single Axle Trailer Frame Assembly (Side Discharge)	585/700
	M1-7-0001-1	1	Single Axle Trailer Frame Assembly (Front Discharge)	585/700
	M1-7-0023-1	1	Single Axle Trailer Frame Assembly (Side Discharge)	F2-585/F2-700
	M1-7-0019-1	1	Single Axle Trailer Frame Assembly (Front Discharge)	F2-585/F2-700
2	75-0209	4	Hub, 8,000# Capacity	585/700
	75-0222	4	Hub, 10,000# Capacity	F2-585/F2-700
3	956-3806	1	8,000# Square Jack Without Mount Tube	All Models
4	M1-7-0006-L	4	Spindle, 2.725" x 14.25" With Nut, Washer, Cotter Pin	585/700
	M1-7-0028-2	4	Spindle, 3-1/4" x 14-1/4"	F2-585/F2-700
5	75-0205-7	4	Spindle Washer	All Models
6	75-0205-8	4	Spindle Nut	All Models
7	75-0205-9	4	Cotter Pin	All Models
8	M1-8-0010	1	Adjustable Hitch Front Plate	All Models
9	See Page 96	1	PTO Shroud	All Models
10	M11-7-0007	1	Load Cell Wire Storage Cover	All Models
11	Call 1-800-325-9103	4	Tire & Wheel	All Models
12	See Page 80	4	2.875" x 14" Load Cell	All Models
13	See Page 80	4	DB Bar Mount	All Models
14	881-7510-1.75Z	6	3/4"-10 x 1-1/2" Machine Bolt Grade 8	All Models
15	822-0075-Z	6	3/4" Split Lock Washer	All Models
16	851-7510-5Z	2	3/4"-10 x 5" Grade 5 Bolt Zinc	All Models
17	815-7510-Z	2	3/4"-10 Nylon Insert Lock Nut	All Models
18	52-0051	1	Safety Chain, 40,000# Capacity	All Models
19	M1-7-0020	1	Left Gearbox Mount Weldment (Power Shift Models Only)	F2-585/F2-700
20	M1-7-0021	1	Right Gearbox Mount Weldment (Power Shift Models Only)	F2-585/F2-700

TANDEM AXLE TRAILER

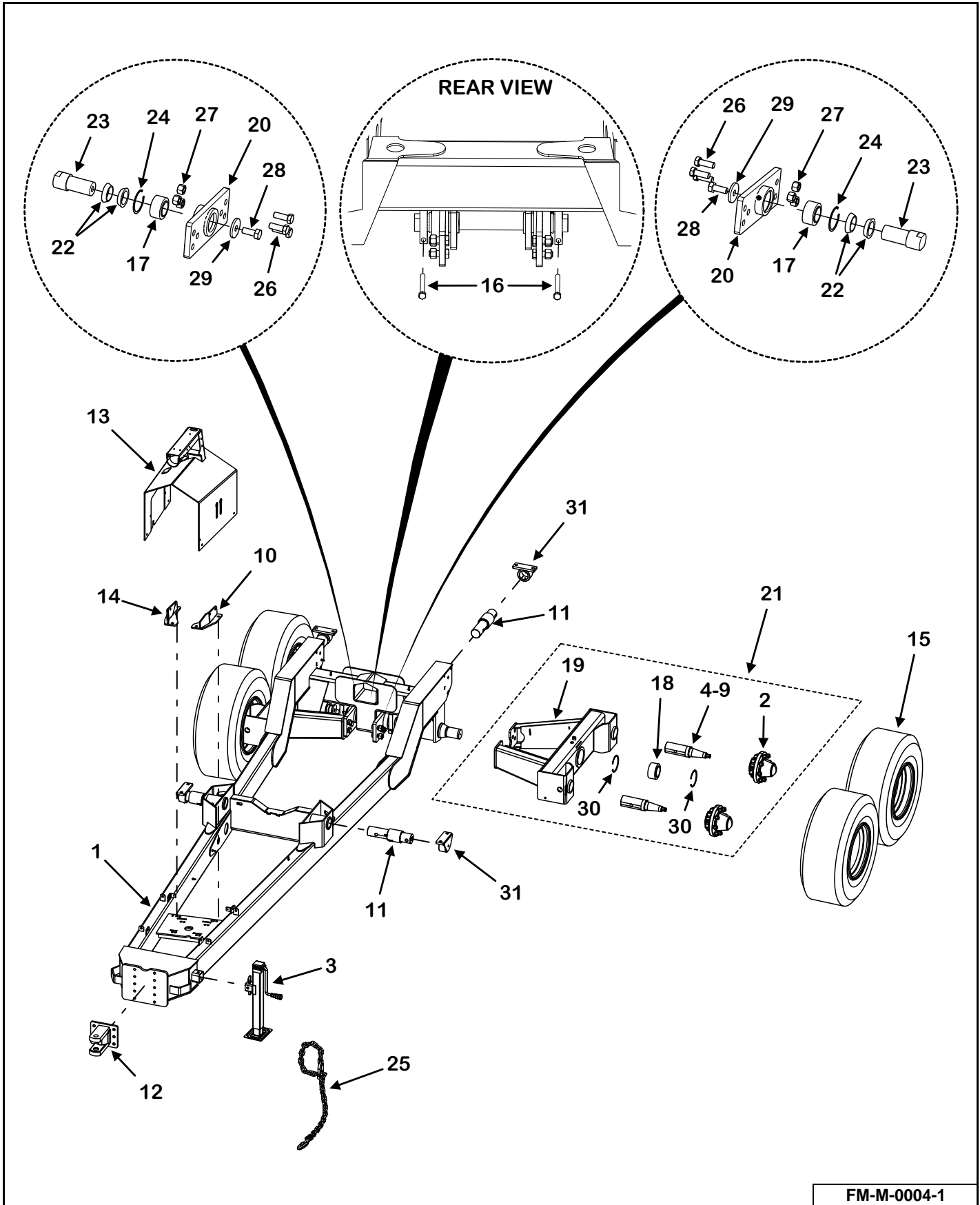

KEY	PART NUMBER	QTY	DESCRIPTION	MIXER MODEL
1	M1-7-0015-1	1	Tandem Axle Trailer Frame Assembly (Front Discharge)	585/700
	M1-7-0024-1	1	Tandem Axle Trailer Frame Assembly (Side Discharge)	F2-585/F2-700
	M1-7-0027-1	1	Tandem Axle Trailer Frame Assembly (Front Discharge)	F2-585/F2-700
2	See Page 98	4	Hub, 8,000# Capacity	585/700
	See Page 99	4	Hub, 10,000# Capacity	F2-585/F2-700
3	956-3806	1	8,000# Square Jack With Storage Mount Tube	All Models
4	M1-7-0006-L	4	Spindle, 2.725" x 14.250" With Nut, Washer, Cotter Pin	585/700
	M1-7-0028-2	4	Spindle, 3-1/4" x 14-1/4"	F2-585/F2-700
5	75-0205-7	4	Spindle Washer	All Models
6	75-0205-8	4	Spindle Nut	All Models
7	75-0205-9	4	Cotter Pin	All Models
8	851-7510-5Z	4	3/4"-10 x 5" Bolt	All Models
9	815-7510-Z	8	3/4"-10 Nylon Insert Lock Nut	All Models
10	M1-7-0020	1	Left Gearbox Mount Weldment (Power Shift Models Only)	F2-585/F2-700
11	See Page 80	4	2.875" x 14" Load Cell	All Models
12	M1-8-0010	1	Adjustable Hitch Front Plate (Stop & Shift Models Only)	All Models
	881-7510-1.75Z	6	3/4"-10 x 1-1/2" Machine Bolt Grade 8	All Models
	822-0075-Z	6	3/4" Split Lock Washer	All Models
13	See Page 96	1	PTO Shroud	All Models
14	M1-7-0021	1	Right Gearbox Mount Weldment (Power Shift Models Only)	F2-585/F2-700
15	Call 1-800-325-9103	4	Call Factory With Model Information	All Models
16	881-7510-7Z	2	3/4"-10 x 7" Machine Bolt Grade 8	All Models
	814-7510-Z	2	3/4"-10 Center Lock Nut	All Models
17	114-VM-0002	2	Plain Spherical Bearing 2.5" ID Motion	All Models
18	914-3822	2	Sealed Spherical Bearing 3" ID x 4.75" OD x 2.625"	All Models
19	M1-7-0013-NHS	2	Tandem O-Beam Assembly (Including Key #'s 18 & 30)	585/700
	M1-7-0028-NHS	2	Tandem O-Beam Assembly (Including Key #'s 18 & 30)	F2-585/F2-700
20	M1-12-0017	2	Tandem Inner Bearing Weldment With Grease Fittings	All Models

TANDEM AXLE TRAILER (CONT'D)

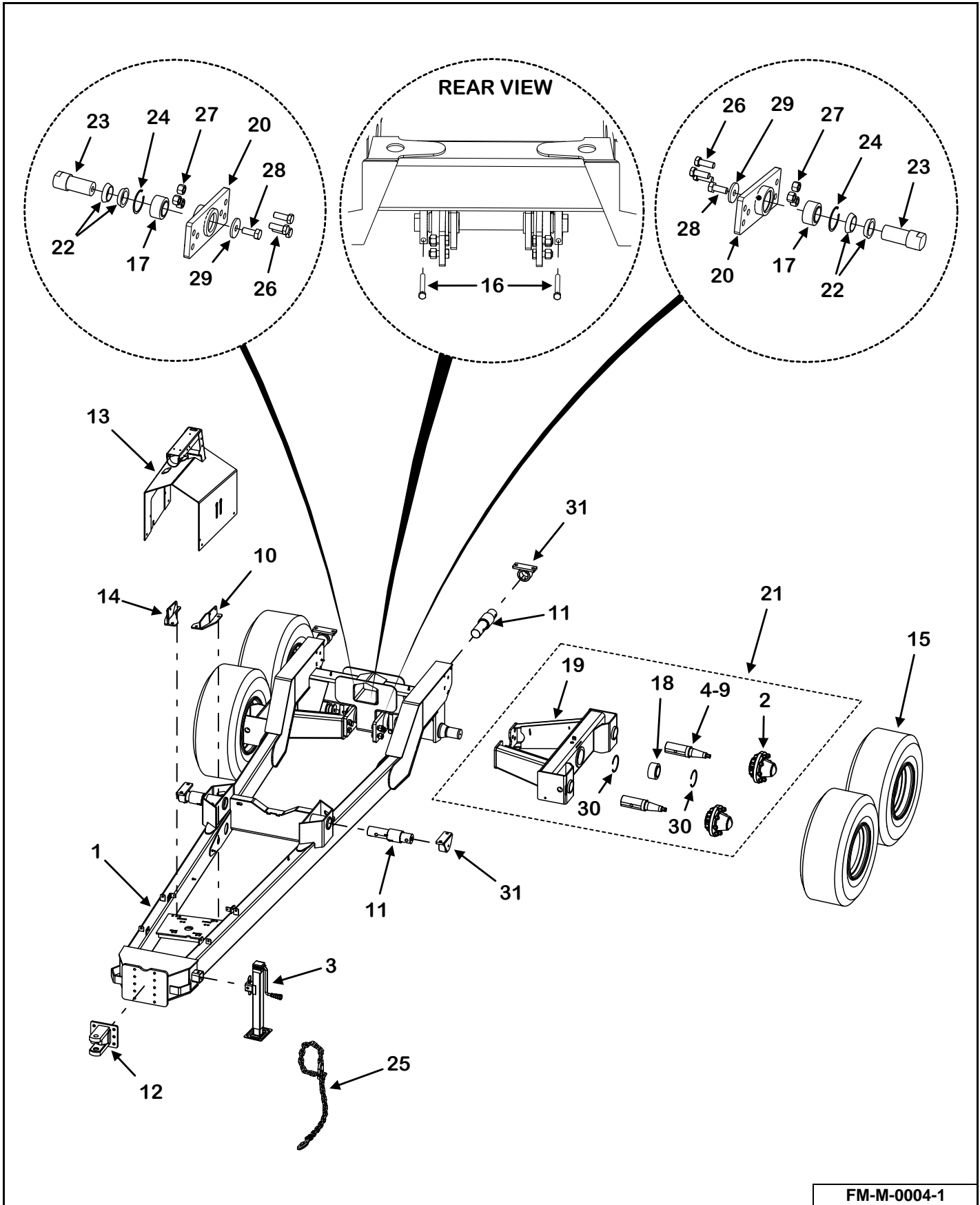

FM-M-0004-1

KEY	PART NUMBER	QTY	DESCRIPTION	MIXER MODEL
21	M1-7-0013-R	1	Right Tandem O-Beam Assembly (Including Key #'s 17, 20, 24, 26 & 27)	585/700
	M1-7-0013-NHR	1	Right Tandem O-Beam Assembly Without Hubs (Including Key #'s 17, 20, 24, 26 & 27)	585/700
	M1-7-0013-L	1	Left Tandem O-Beam Assembly (Including Key #'s 17, 21, 24, 26 & 27)	585/700
	M1-7-0013-NHL	1	Left Tandem O-Beam Assembly Without Hubs (Including Key #'s 17, 21, 24, 26 & 27)	585/700
	M1-7-0028-NH	2	Right Tandem O-Beam Assembly (Including Key #'s 17, 20, 24, 26 & 27)	F2-585/F2-700
22	M1-10-0004-1-1	4	Tandem Inner Bearing Torque Collar	All Models
23	M1-10-0004-1-2	2	Tandem Inner Bearing Pin	All Models
24	33-0056	2	Internal Snap Ring Fits 3.938" ID Tube	All Models
25	52-0051	1	Safety Chain, 40,000# Capacity	All Models
26	851-1008-2.75Z	12	1"-8 x 2-3/4" Bolt	All Models
27	884-1008	12	1"-8 Lock Nut	All Models
28	881-1014-2.5Z	2	1"-14 x 2-1/2" Bolt (Torque to 500 ft./lbs. lubricated)	All Models
29	M1-10-0004-1-3	2	Inner Bearing Washer	All Models
30	33-0057	4	4-3/4" Internal Snap Ring	All Models
31	See Page 80	4	DB Bar Mount	All Models

585 & 700 PTO SHROUD

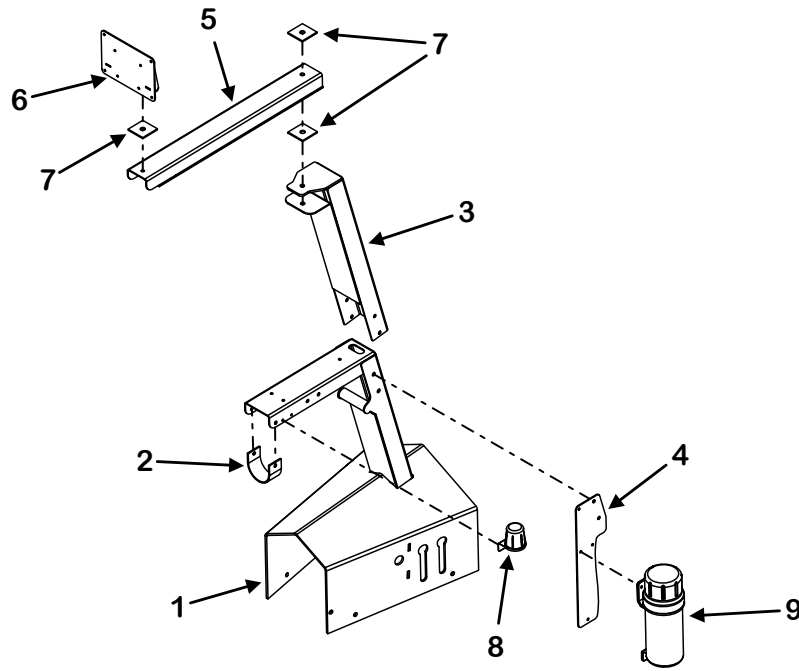

FM-ML-0047-1

F2 PTO SHROUD

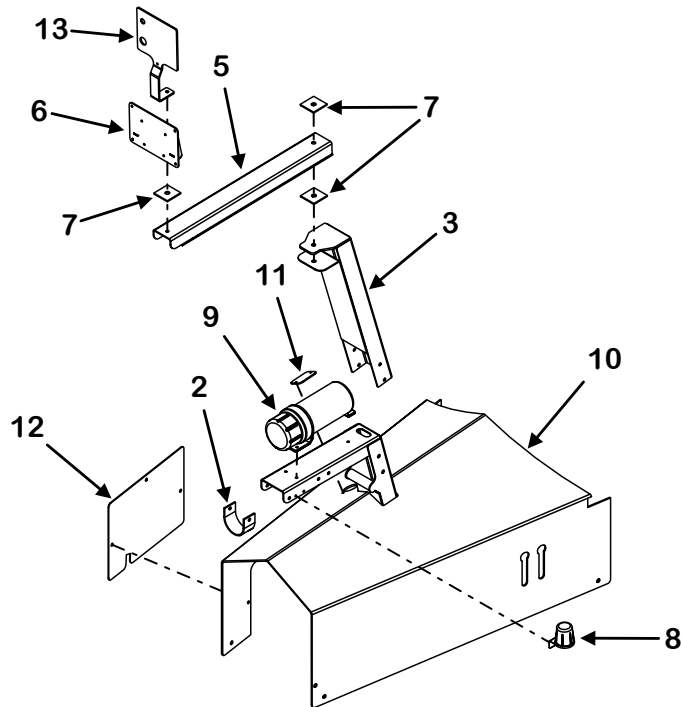

FM-M-0005-1

KEY	PART NUMBER	QTY	DESCRIPTION	MIXER MODEL
1	M8-1-7-0005	1	PTO Shroud (Side Discharge) (Single Axle Trailer)	585/700
	M8-1-7-0001	1	PTO Shroud (Front Discharge)	585/700
	M8-12-0001-1	1	PTO Shroud (Side Discharge) (Tandem Axle Trailer)	585/700
2	M8-1-8-0006-7	1	Rubber Hose Holder	All Models
3	M9-1-8-0007	1	Scale Mount Extension Weldment (Without Platform Only)	All Models
4	M8-1-4-0004	1	Manual Holder Mount	585/700
5	M9-1-4-0001	1	Load Display Pivot Arm (Without Platform Only)	All Models
6	M9-1-8-0002	1	Scale Indicator Mount (Without Platform Only)	All Models
7	M9-1-8-0004	3	Scale Arm Rubber Washer (Without Platform Only)	All Models
8	56-0009	1	Plug Holder	585/700
9	33-0060	1	Manual Holder	585/700
10	M8-1-7-0009	1	PTO Shroud (Side Discharge) (Single Axle Trailer)	F2-585/F2-700
	M8-1-7-0007	1	PTO Shroud (Front Discharge) (Single Axle Trailer)	F2-585/F2-700
	M8-1-7-0010	1	PTO Shroud (Side Discharge) (Tandem Axle Trailer)	F2-585/F2-700
	M8-1-7-0008	1	PTO Shroud (Front Discharge) (Tandem Axle Trailer)	F2-585/F2-700
11	M8-1-7-0007-2	1	Indicator Light Bracket	F2-585/F2-700
12	M11-1-0067-6	1	Filter Cover Plate	F2-585/F2-700
13	MN11-1-0002-3	1	Indicator Light Bracket (Power Shift Models Only)	F2-585/F2-700

75-0209 HUB ASSEMBLY

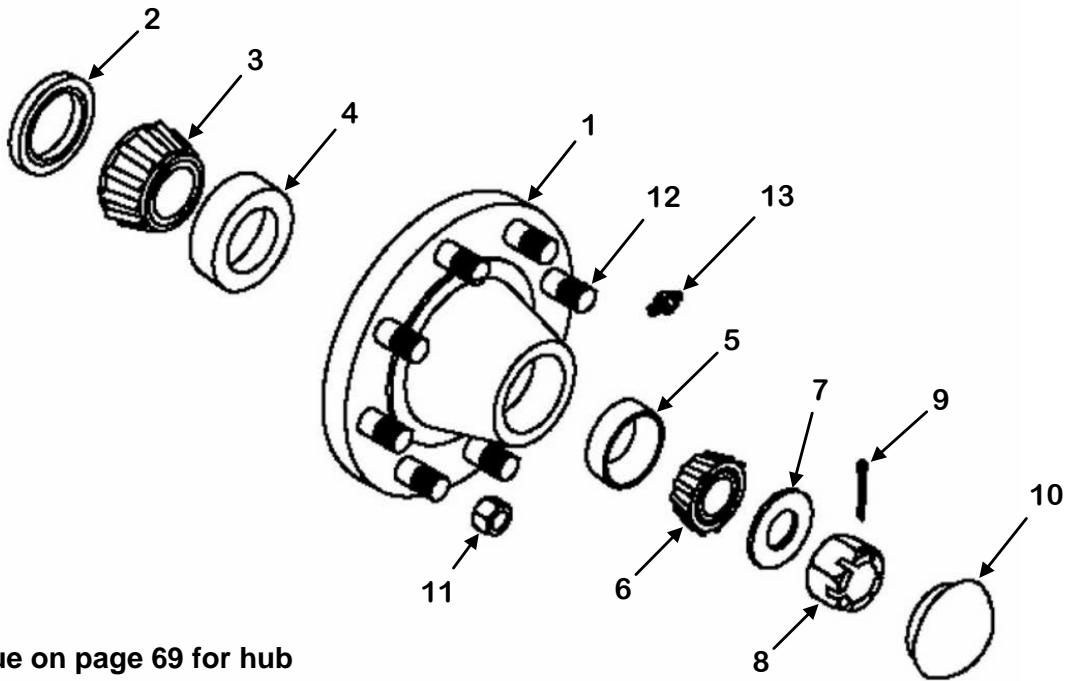

See Hub Torque on page 69 for hub installation. See Wheel Torque on page 69 for wheel installation.

75-0209

KEY	PART NUMBER	QTY	DESCRIPTION
0	75-0209	4	Hub, Complete Assembly
1	75-0207-1	1	Hub With Races
2	75-0209-2	1	Grease Seal
3	75-0207-3	1	Inner Wheel Bearing
4	75-0207-4	1	Inner Wheel Race
5	75-0202-4	1	Outer Wheel Race
6	75-0202-3	1	Outer Wheel Bearing
7	75-0205-7	1	Washer
8	75-0205-8	1	Nut
9	75-0205-9	1	Cotter Pin
10	75-0205-10	1	Cap
11	75-0205-11-H	8	5/8"-18 Lug Nut, Grade 5, Torque 160 ft/lbs
12	75-0207-12	8	5/8"-18 x 2-1/2" Stud Bolt
13	30-0002	1	1/8" NPS Straight Zerk

75-0222 HUB ASSEMBLY

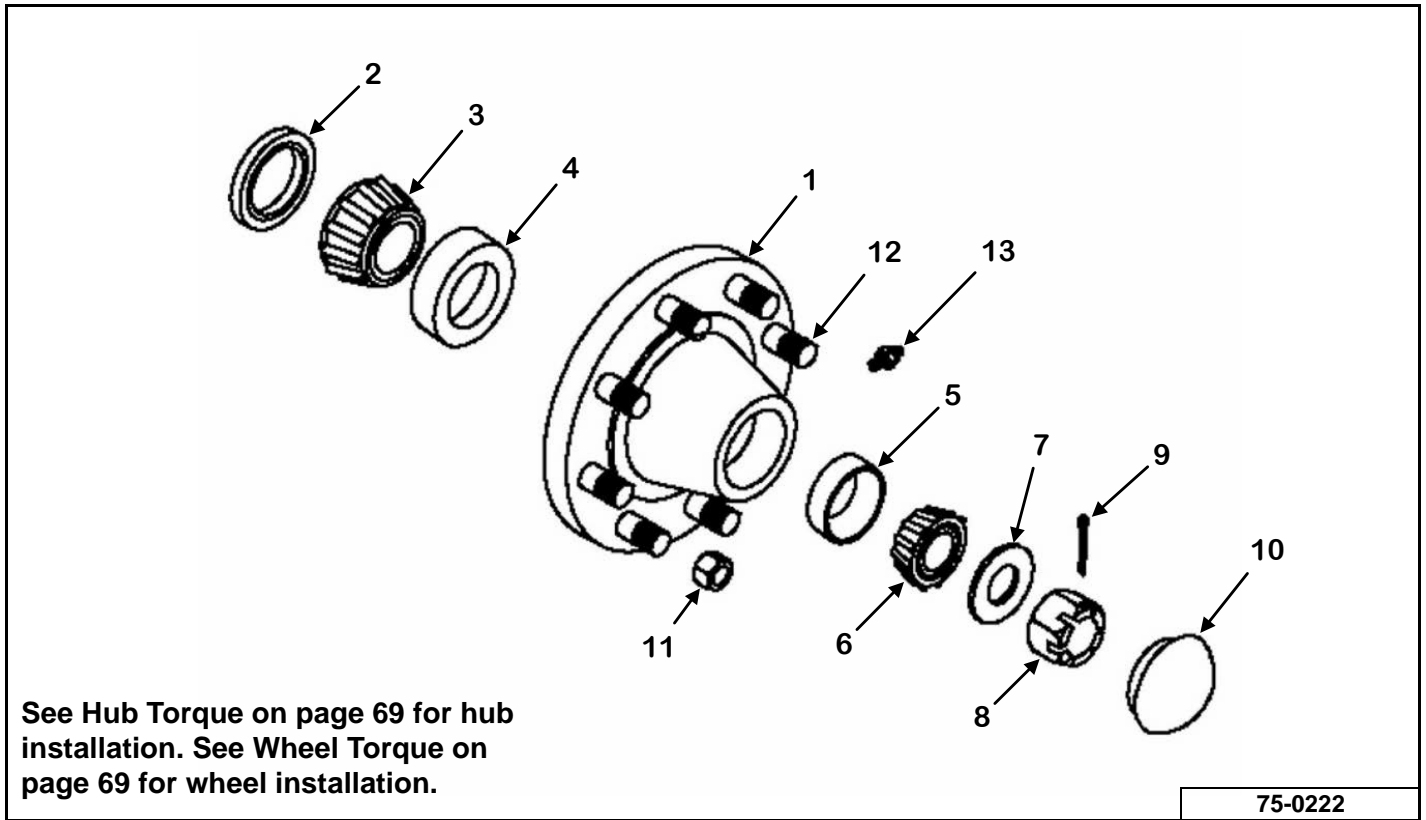

KEY	PART NUMBER	QTY	DESCRIPTION
0	75-0222	1	Hub Assembly
1	75-0222-1	1	Hub With Races
2	75-0222-2	1	Grease Seal
3	75-0222-3	1	Inner Wheel Bearing
4	75-0222-4	1	Inner Wheel Race
5	75-0202-4	1	Outer Wheel Race
6	75-0202-3	1	Outer Wheel Bearing
7	75-0205-7	1	Washer
8	75-0205-8	1	Nut
9	75-0205-9	1	Cotter Pin
10	75-0205-10	1	Cap
11	75-0205-11-H	8	5/8"-18 Lug Nut, Grade 5, Torque 160 ft/lbs
12	75-0207-12	8	5/8"-18 x 2-1/2" Stud Bolt
13	30-0002	1	1/8" NPS Straight Zerk

MIXER

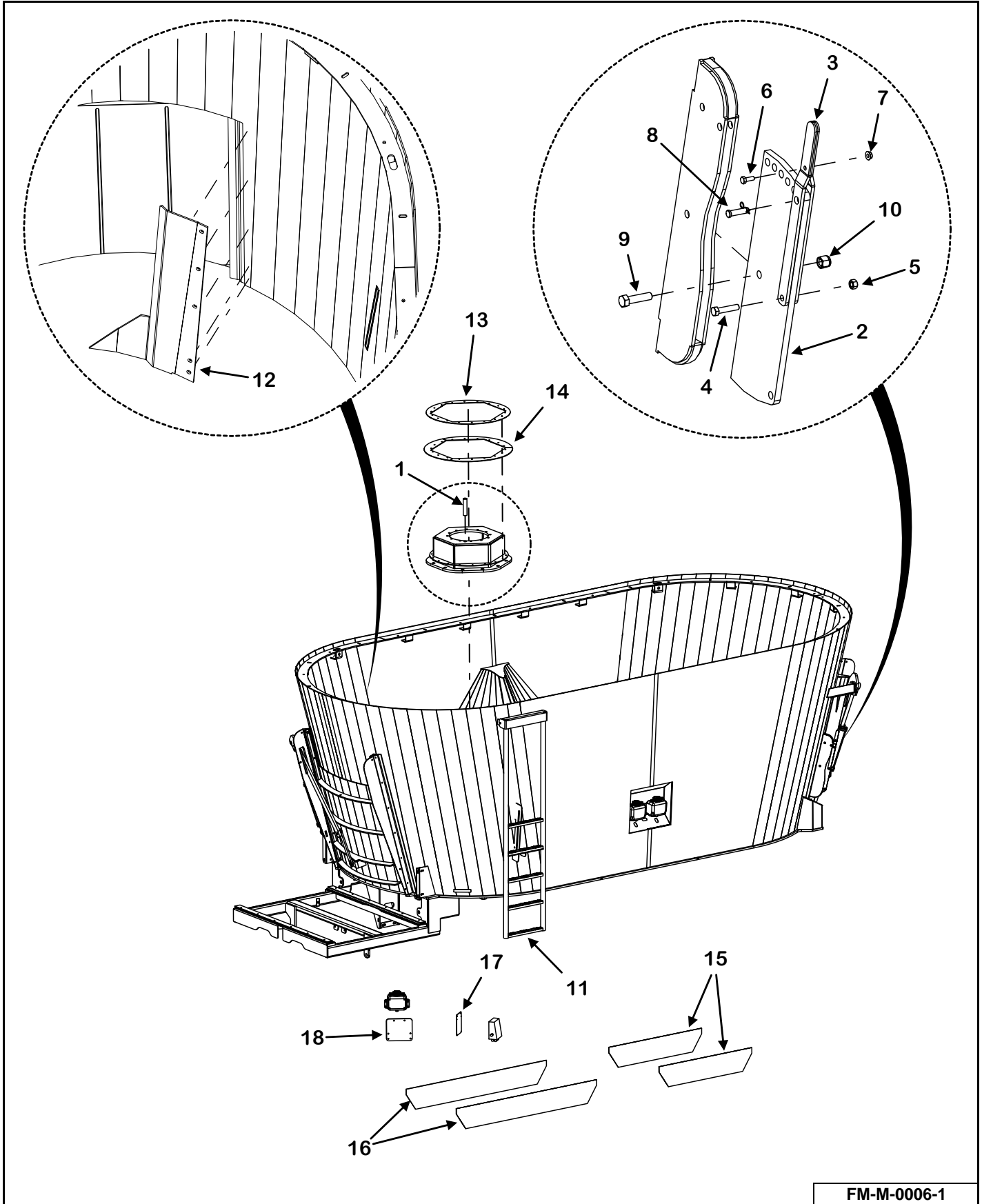

FM-M-0006-1

KEY	PART NUMBER	QTY	DESCRIPTION	MIXER MODEL
1	M2-1-7-0003-3	2	Planetary Mount Tube (Welded On)	All Models
2	M7-1-8-0002	2	Hay Stop	All Models
3	M7-1-8-0003	4	Hay Stop Handle	All Models
4	851-3816-1.75Z	2	3/8"-16 x 1-3/4" Machine Bolt	All Models
5	815-3816-Z	2	3/8"-16 Nylon Insert Lock Nut	All Models
6	851-2520-.75Z	2	1/4"-20 x 3/4" Machine Bolt	All Models
7	810-2520-Z	2	1/4" Spin Lock Nut	All Models
8	32-0042	2	1/2" x 1-1/2" Clevis Pin With Clip	All Models
9	851-5013-2Z	2	1/2"-13 x 2" Machine Bolt	All Models
10	815-5013-Z	2	1/2"-13 Nylon Lock Nut	All Models
11	See Page 152	1	Ladder Weldment	All Models
12	M6-1-7-0016	1	Front/Rear Door Deflector	All Models
	803-3816-1.25Z	5	3/8"-16 x 1-1/4" Flat Head Socket Cap Screw	All Models
	815-3816-Z	5	3/8"-16 Nylon Insert Lock Nut	All Models
13	M2-1-5-0011-3	2	Auger Seal Cover	All Models
	851-3816-1Z	36	3/8"-16 x 1" Machine Bolt	All Models
	815-3816-Z	36	3/8"-16 Nylon Lock Nut	All Models
14	M2-1-5-0011-2	6	Auger Seal Belting	All Models
15	49-0177	2	Belt Skirting	All Models
16	49-0176	2	Belt Skirting	All Models
17	M9-1-8-0005	1	J-Box Mount Plate	All Models
18	M2-1-10-0001-9	1	Oil Tank Mount	585/700

FRONT FLAT & INCLINE BASE BELT CONVEYOR

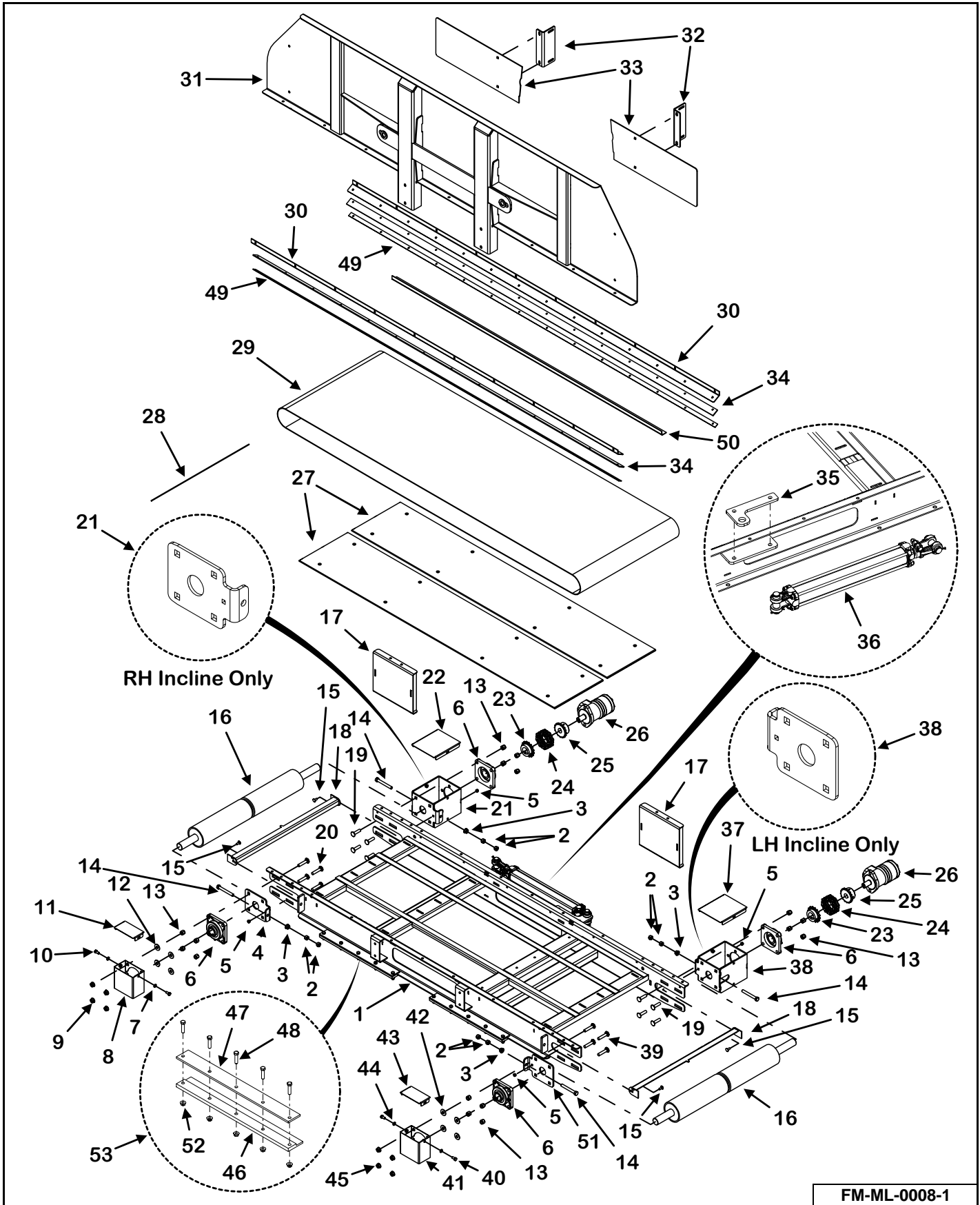

FM-ML-0008-1

KEY	PART NUMBER	QTY	DESCRIPTION	MIXER MODEL
0	VAM-FDB-36-2MI	1	2 Motor Front Discharge Flat Belt Conveyor (Incline Ready)	All Models
	VAM-FDBI-3636-L3	1	3 Motor Front LH Discharge Incline Belt Conveyor (36" Incline)	All Models
	VAM-FDBI-3636-R3	1	3 Motor Front RH Discharge Incline Belt Conveyor (36" Incline)	All Models
	VAM-FDBI-3648-L3	1	3 Motor Front LH Discharge Incline Belt Conveyor (48" Incline)	All Models
	VAM-FDBI-3648-R3	1	3 Motor Front RH Discharge Incline Belt Conveyor (48" Incline)	All Models
	VAM-FDBI-3660-L3	1	3 Motor Front LH Discharge Incline Belt Conveyor (60" Incline)	All Models
1	M3-1-5-0060-1	1	Incline Base Conveyor Weldment	All Models
2	813-5013-Z	8	1/2"-13 Nut	All Models
3	810-5013-Z	4	1/2" Spin Lock Nut	All Models
4	M3-1-5-0044-1	2	Front Conveyor Bearing Mount	All Models
	See Page 218	1	Bearing Mount Weldment (RH Power Magnet)	All Models
5	814-3118-Z	4	5/16"-18 Indented Lock Nut	All Models
6	14-0070	4	1-1/2" 4-Bolt Bearing Narrow Inner Race	All Models
7	822-0038-Z	2	3/8" Split Lock Washer (No Incline, LH Incline)	All Models
8	M3-1-8-0047	1	Shaft Cover Weldment (No Incline, LH Incline)	All Models
9	810-5013-Z	4	1/2" Spin Lock Nut (No Incline, LH Incline)	All Models
10	851-3816-.75Z	2	3/8"-16 x 3/4" Machine Bolt (No Incline, LH Incline)	All Models
11	M3-1-8-0048	1	Shaft Cover Plate (No Incline, LH Incline)	All Models
12	805-0050-Z	4	1/2" Flat Washer (No Incline, LH Incline)	All Models
13	815-5013-Z	16	1/2"-13 Nylon Lock Nut	All Models
14	830-5013-4Z	4	1/2"-13 x 4" Tap Bolt Full Threaded	All Models
15	850-3118-.75Z	4	5/16"-18 x 3/4" Carriage Bolt	All Models
16	23-0269	2	Drive Pulley Urethane Lagged	All Models
17	M3-1-7-0051	2	Conveyor Shield Weldment (Front Flat Sliding Conveyor Only)	All Models
18	M3-1-10-0023	2	Conveyor Pulley Scraper	All Models
19	850-5013-1.75Z	8	1/2"-13 x 1-3/4" Carriage Bolt	All Models
20	850-5013-2.25Z	4	1/2"-13 x 2-1/4" Carriage Bolt (No Incline, LH Incline)	All Models
	850-5013-1.75Z	4	1/2"-13 x 1-3/4" Carriage Bolt (RH Incline)	All Models
21	M3-1-8-0046	1	Front Conveyor Motor Mount Weldment (No Incline, LH Incline)	All Models
	M3-1-5-0044-1	1	Front Conveyor Bearing Mount (RH Incline)	All Models
	See Page 218	1	Motor Mount Weldment (RH Power Magnet)	All Models
22	M3-1-8-0045	1	Chain Coupler Cover Plate (No Incline, LH Incline)	All Models
	851-3816-.75Z	2	3/8"-16 x 3/4" Machine Bolt (No Incline, LH Incline)	All Models
	822-0038-Z	2	3/8" Split Lock Washer (No Incline, LH Incline)	All Models

FRONT FLAT & INCLINE BASE BELT CONVEYOR (CONT'D)

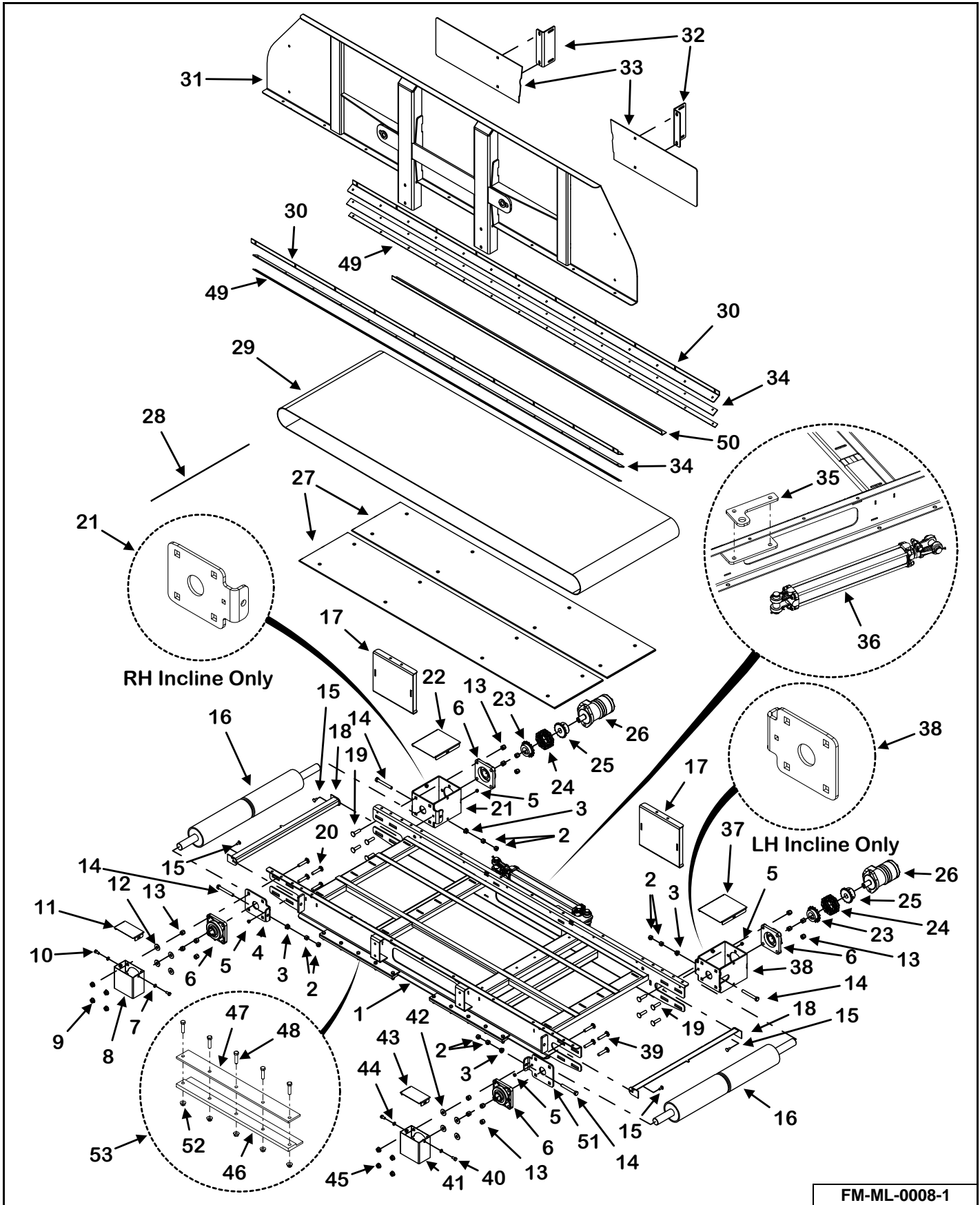

FM-ML-0008-1

KEY	PART NUMBER	QTY	DESCRIPTION	MIXER MODEL
23	110-50B16-1.50-1	2	Coupler Sprocket	All Models
	35-0006	2	Key	All Models
24	37-0013-2	2	Coupler Chain	All Models
25	37-0013-1	2	Coupler Sprocket	All Models
26	See Page 108	2	12.1 Cubic Inch 2-Bolt Motor	All Models
	135-2525-1.25-1	2	Key	All Models
27	M3-1-5-0060-3	2	Front Belt Discharge Conveyor Floor	All Models
	803-3118-1Z	16	5/16"-18 x 1" Flat Socket Head Cap Screw	All Models
	805-0031-Z	16	5/16" Flat Washer	All Models
	815-3118-Z	16	5/16"-18 Nylon Insert Lock Nut	All Models
28	49-0156-6-AS	1	Conveyor Belt Lacing Pin Kit	All Models
29	49-0247-MB	1	Front Conveyor Mini Bite Belt	All Models
30	VAM-FCS	1	Skirt Seal Kit (SN 19VM0585201 Only)	585/700
	M3-1-5-0060-6	2	Front Conveyor Skirt Bracket (Excluding SN 19VM0585201)	All Models
31	M3-1-5-0061	1	Base Conveyor Front Panel Weldment	All Models
32	M3-1-7-0021	2	Front Conveyor Shield Mounting Bracket	All Models
33	M3-1-7-0024	2	Front Conveyor Shield	All Models
34	VAM-FCS	1	Skirt Seal Kit (SN 19VM0585201 Only)	585/700
	49-0339	2	Base Conveyor Skirting (Excluding SN 19VM0585201)	All Models
35	M3-1-8-0011	1	Front Conveyor Cylinder Mount (Front Flat Sliding Conveyor Only) Prior to SN 20VM(0585201, 0700201)	585/700
	M3-1-8-0057	1	Front Conveyor Cylinder Mount (Front Flat Sliding Conveyor Only) SN 20VM(0585201, 0700201) & Later	All Models
	851-5013-1.75Z	2	1/2"-13 x 1-3/4" Machine Bolt (Front Flat Sliding Conveyor Only)	All Models
	810-5013-Z	2	1/2" Spin Lock Nut (Front Flat Sliding Conveyor Only)	All Models
36	See Page 108	1	Front Flat Belt Conveyor Hydraulic Schematic	All Models
37	M3-1-8-0045	1	Chain Coupler Cover Plate (No Incline, RH Incline)	All Models
	851-3816-.75Z	2	3/8"-16 x 3/4" Machine Bolt (No Incline, RH Incline)	All Models
	822-0038-Z	2	3/8" Split Lock Washer (No Incline, RH Incline)	All Models
38	M3-1-8-0046	1	Front Conveyor Motor Mount Weldment (No Incline, RH Incline)	All Models
	M3-1-5-0044-1	1	Front Conveyor Bearing Mount (LH Incline)	All Models
	See Page 242	1	Motor Mount Weldment (LH Power Magnet)	All Models

FRONT FLAT & INCLINE BASE BELT CONVEYOR (CONT'D)

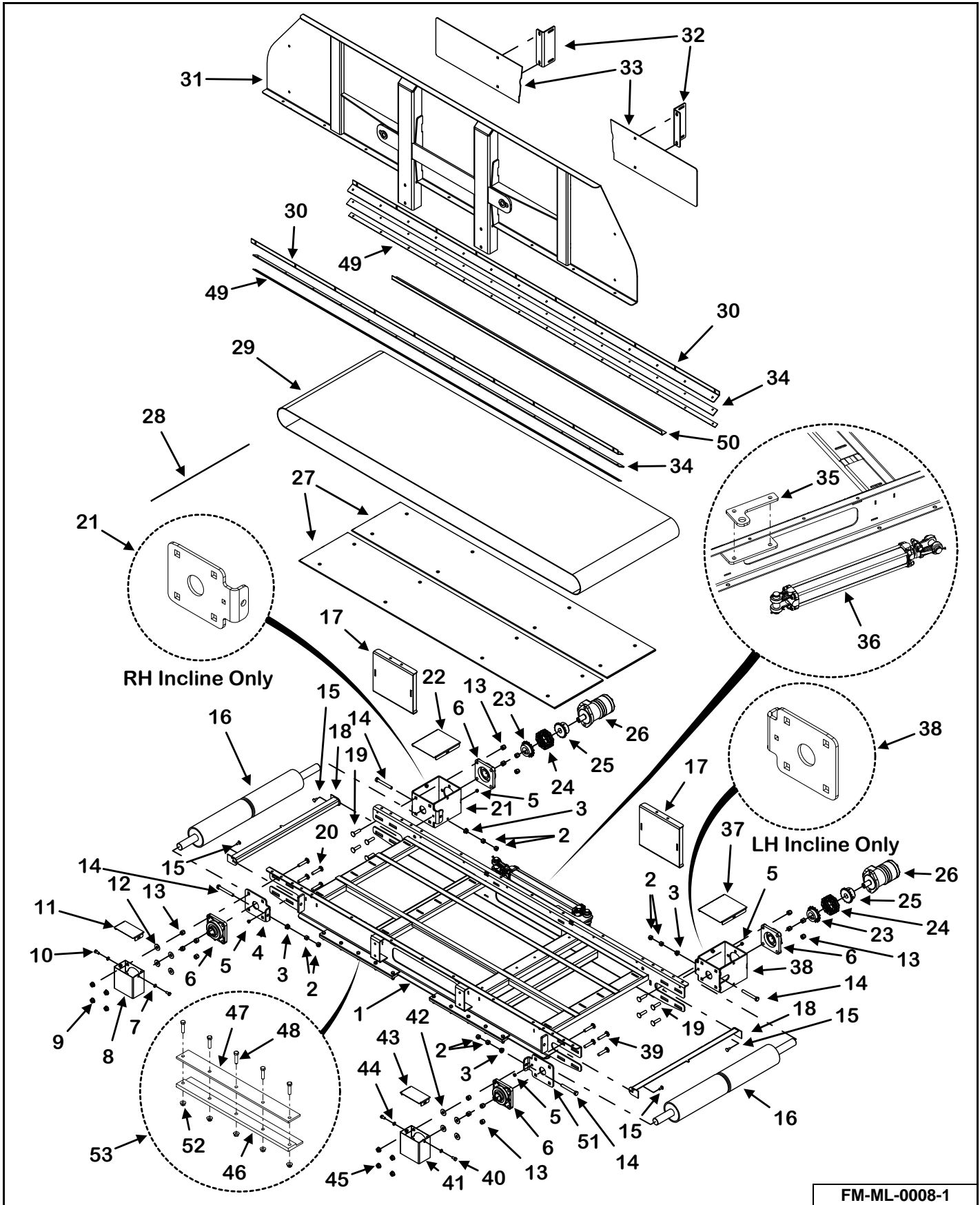

FM-ML-0008-1

KEY	PART NUMBER	QTY	DESCRIPTION	MIXER MODEL
39	850-5013-2.25Z	4	1/2"-13 x 2-1/4" Carriage Bolt (No Incline, RH Incline)	All Models
	850-5013-1.75Z	4	1/2"-13 x 1-3/4" Carriage Bolt (LH Incline)	All Models
40	851-3816-.75Z	2	3/8"-16 x 3/4" Machine Bolt (No Incline, RH Incline)	All Models
41	M3-1-8-0047	1	Shaft Cover Weldment (No Incline, RH Incline)	All Models
42	805-0050-Z	4	1/2" Flat Washer (No Incline, RH Incline)	All Models
43	M3-1-8-0048	1	Shaft Cover Plate (No Incline, RH Incline)	All Models
44	822-0038-Z	2	3/8" Split Lock Washer (No Incline, RH Incline)	All Models
45	810-5013-Z	4	1/2" Spin Lock Nut (No Incline, RH Incline)	All Models
46	VAM-CSK	1	Conveyor Slide Update Kit (Flat Sliding Conveyor Only) Prior to SN 20VM(0585211, 0700204)	585/700
	M3-1-7-0056	4	Conveyor Bottom Slide (Flat Sliding Conveyor Only) SN 20VM(0585211, 0700204) & Later	All Models
47	VAM-CSK	1	Conveyor Slide Update Kit (Flat Sliding Conveyor Only) Prior to SN 20VM(0585211, 0700204)	585/700
	M3-1-7-0057	4	Conveyor Slide Cap (Flat Sliding Conveyor Only) SN 20VM(0585211, 0700204) & Later	All Models
48	851-3816-1.5Z	20	3/8"-16 x 1-1/2" Hex Cap Screw	All Models
49	VAM-FCS	1	Skirt Seal Kit (SN 19VM0585201 Only)	585/700
	M3-1-5-0060-7	2	Front Conveyor Skirt Backer (Excluding SN 19VM0585201)	All Models
50	M3-1-5-0060-2	1	Floor Seal	All Models
51	M3-1-5-0044-1	1	Front Conveyor Bearing Mount	All Models
	See Page 134	1	Bearing Mount Weldment (LH Power Magnet)	All Models
52	810-3816-Z	20	3/8"-16 Spin Lock Nut	All Models
53	VAM-CSK	1	Conveyor Slide Update Kit (Flat Sliding Conveyor Only) Prior to SN 20VM(0585211, 0700204)	585/700
	M3-1-7-0056-AS	4	Conveyor Bottom Slide With Cap & Hardware (Flat Sliding Conveyor Only) SN 20VM(0585211, 0700204)& Later	All Models

FRONT FLAT BELT CONVEYOR HYDRAULIC SCHEMATIC

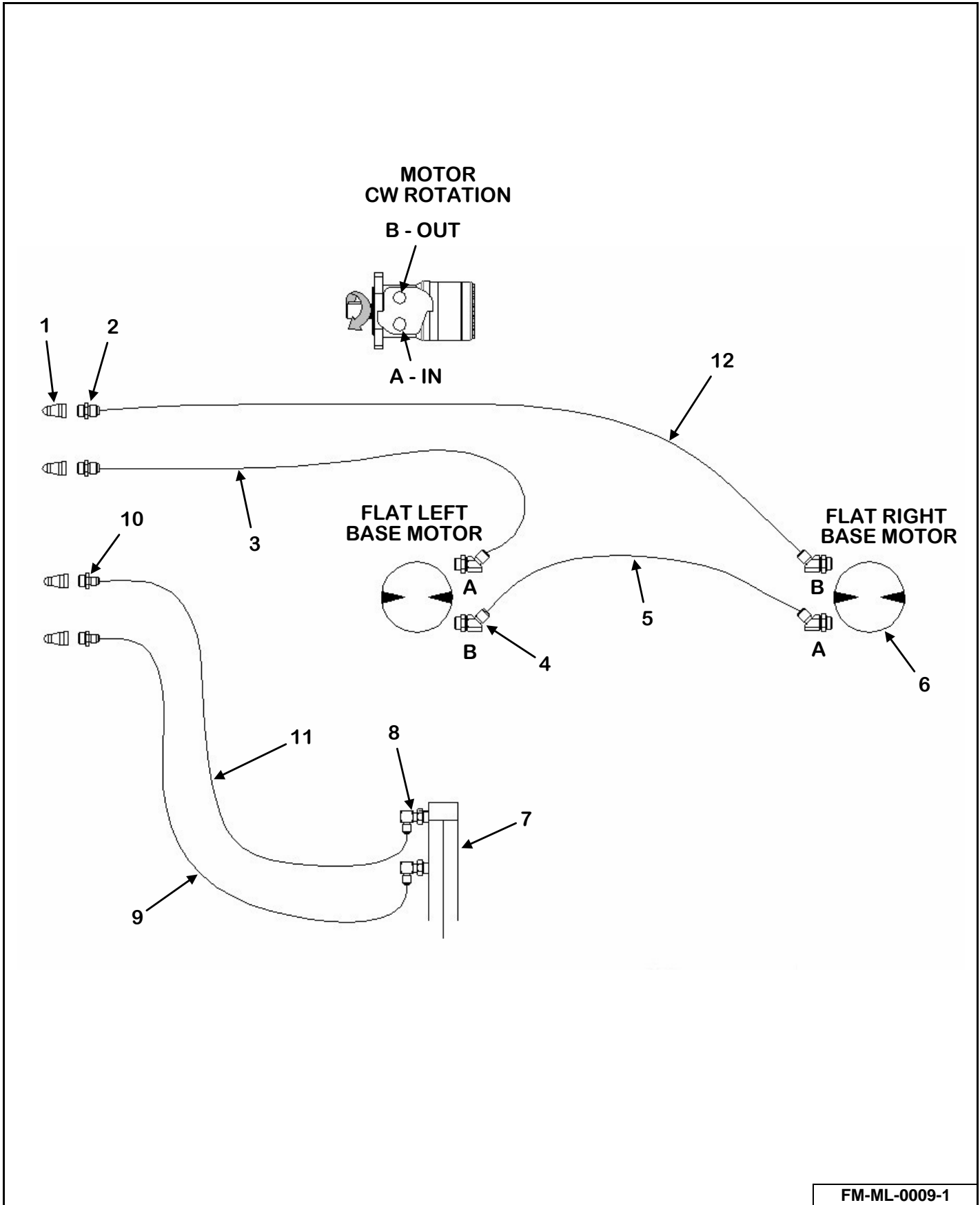

FM-ML-0009-1

KEY	PART NUMBER	QTY	DESCRIPTION	MIXER MODEL
1	155-8010-15	4	#8 ORB Male Tip 1/2" Body Size	All Models
2	155-6400-8-8	2	#8 JIC Male, #8 ORB Male Straight Connector	All Models
3	155-08R17-189-1	2	1/2" x 189" Hose Assembly	585/700
	155-08R17-192-1	1	1/2" x 192" Hose Assembly	F2-585/F2-700
4	155-6802-8-10	4	#8 JIC Male, #10 ORB Male Adjustable 45°	All Models
5	155-08R17-166-1	1	1/2" x 166" Hose Assembly	585/700
	155-08R17-126-1	1	1/2" x 126" Hose Assembly	F2-585/F2-700
6	155-WR-12.1-1	2	12.1 Cubic Inch 2-Bolt Motor	All Models
	155-WR-SK-1	AR	Motor Seal Kit	All Models
7	155-2-16-1.125-2	1	2" x 16" x 1-1/8" Hydraulic Cylinder, Modified Port Prior to SN 20VM(0585201, 0700201)	585/700
	155-2-14-1.125-1	1	2" x 14" x 1-1/8" Hydraulic Cylinder, Modified Port SN 20VM(0585201, 0700201) & Later	All Models
	155-2-1.125-1-DSK	1	Cylinder Seal Kit	All Models
8	155-6801-6-8	2	#6 JIC Male, #8 ORB Male Adjustable 90°	All Models
9	155-04R17-185-1	1	1/4" x 185" Hose Assembly	585/700
	155-04R17-193-1	1	1/4" x 193" Hose Assembly	F2-585/F2-700
10	155-6400-6-8	2	#6 JIC Male, #8 ORB Male Straight Connector	All Models
11	155-04R17-173-1	1	1/4" x 173" Hose Assembly	585/700
	155-04R17-193-1	1	1/4" x 193" Hose Assembly	F2-585/F2-700

FRONT INCLINE BELT CONVEYOR

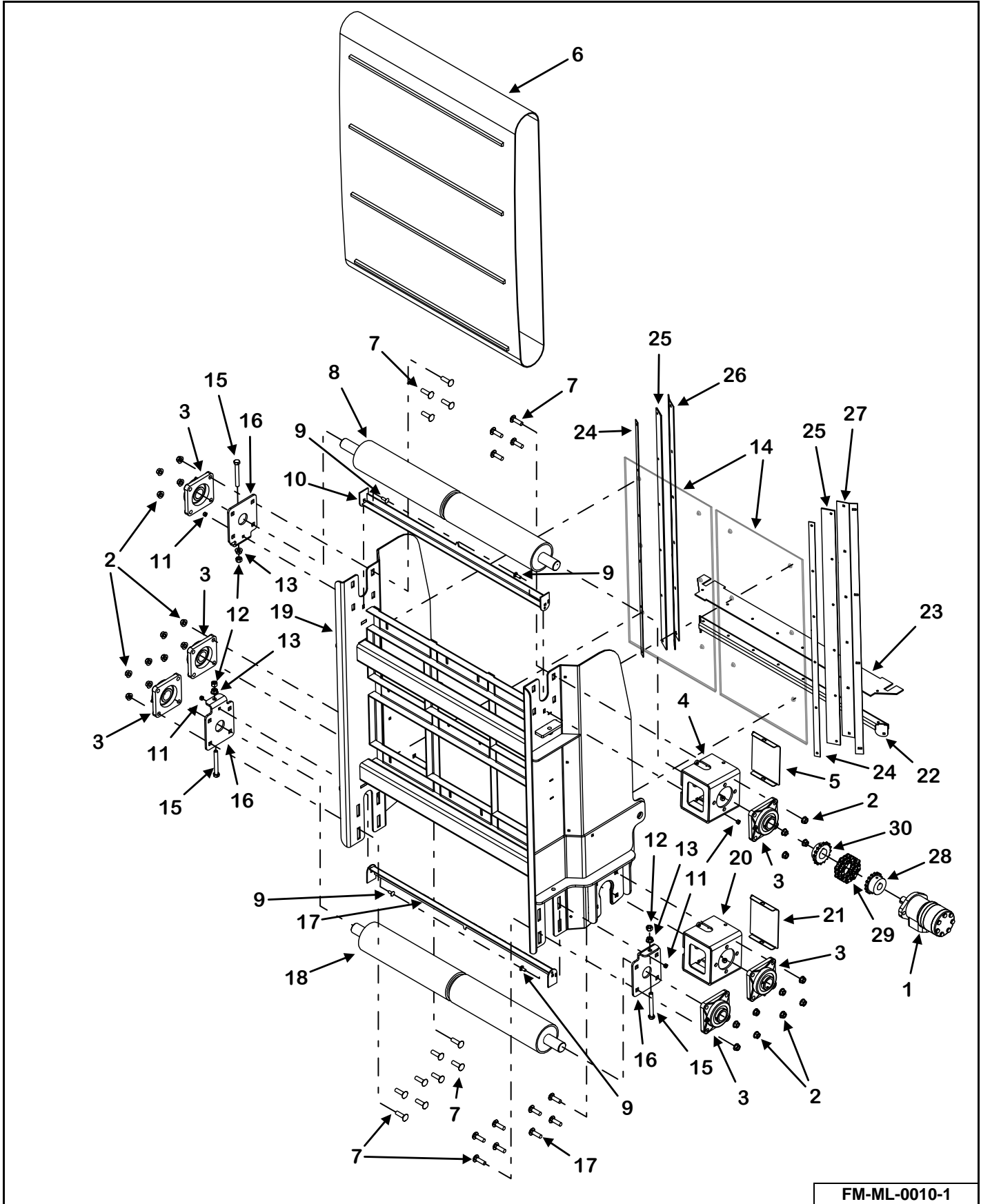

KEY	PART NUMBER	QTY	DESCRIPTION	MIXER MODEL
0	VAM-FDB-LI36K	1	36" Front LH Belt Conveyor, Incline Section Only Kit	All Models
	VAM-FDB-RI36K	1	36" Front RH Belt Conveyor, Incline Section Only Kit	All Models
	VAM-FDB-LI48K	1	48" Front LH Belt Conveyor, Incline Section Only Kit	All Models
	VAM-FDB-RI48K	1	48" Front RH Belt Conveyor, Incline Section Only Kit	All Models
1	See Page 118	1	7.9 Cubic Inch 2-Bolt Motor	All Models
	135-2525-1.25-1	1	Key	All Models
2	810-5013-Z	24	1/2" Spin Lock Nut	All Models
3	14-0070	6	1-1/2" 4-Bolt Bearing Narrow Inner Race	All Models
4	M3-1-5-0049	1	Conveyor Motor Mount Weldment	All Models
5	M3-1-8-0006	1	Coupler Cover Plate	All Models
	851-3816-.75Z	2	3/8"-16 x 3/4" Machine Bolt	All Models
	822-0038-Z	2	3/8" Split Lock Washer	All Models
6	49-0232-MB	1	24" Incline Mini Bite Belt	All Models
	49-0168-MB	1	36" Incline Mini Bite Belt	All Models
	49-0195-MB	1	48" Incline Mini Bite Belt	All Models
	49-0196-MB	1	60" Incline Mini Bite Belt	All Models
	49-0216-MB	1	72" Incline Mini Bite Belt	All Models
	49-0156-6-AS	1	Conveyor Belt Lacing Pin Kit	All Models
7	850-5013-1.75Z	20	1/2"-13 x 1-3/4" Carriage Bolt	All Models
8	23-0251	1	Drive Pulley Urethane Lagged	All Models
9	850-3118-1Z	4	5/16"-18 x 1" Carriage Bolt	All Models
10	M3-1-10-0023	2	Conveyor Pulley Scraper	All Models
11	814-3118-Z	4	5/16"-18 Indented Lock Nut	All Models
12	813-5013-Z	3	1/2"-13 Nut	All Models
13	810-5013-Z	3	1/2" Spin Lock Nut	All Models

FRONT INCLINE BELT CONVEYOR (CONT'D)

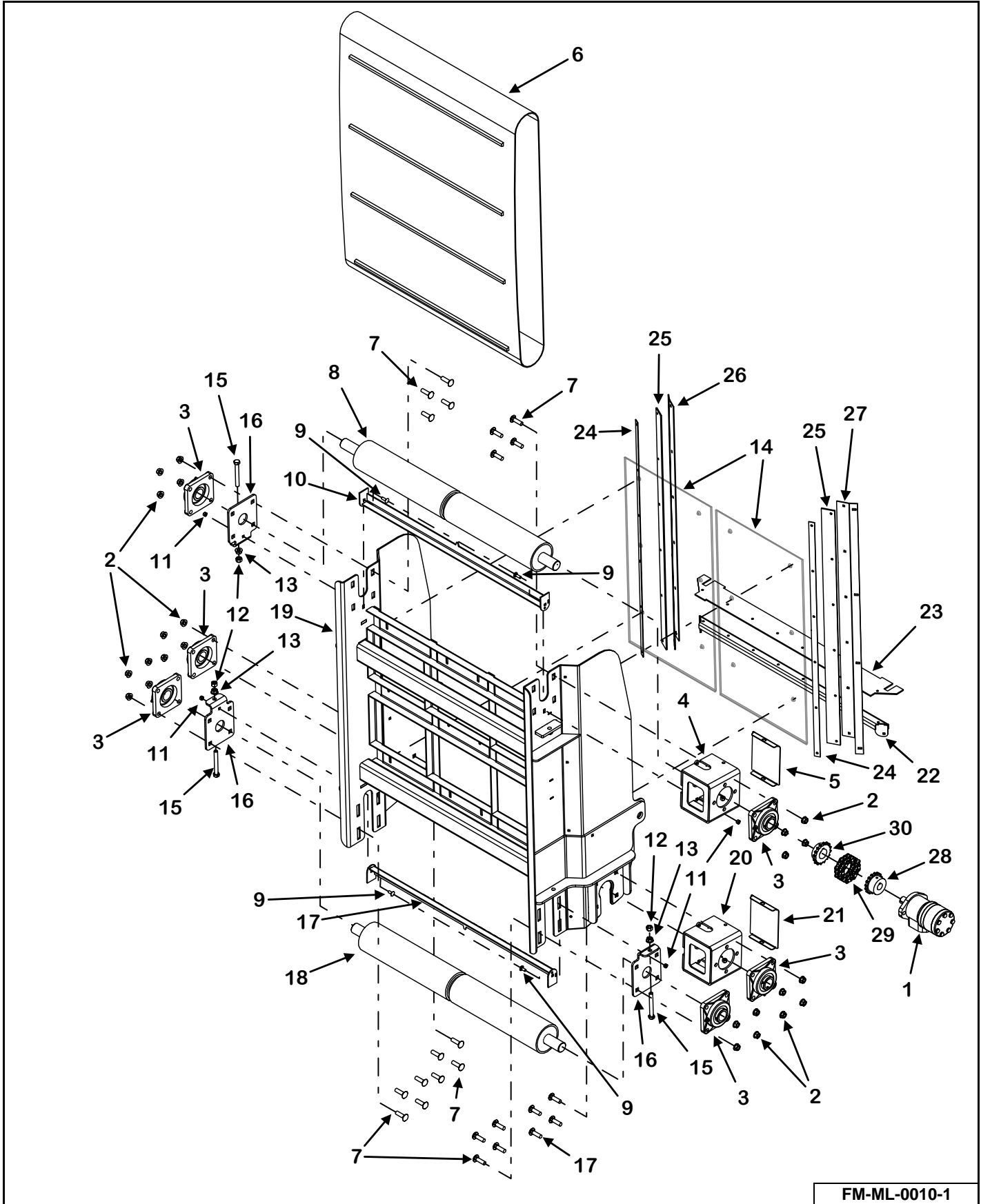

FM-ML-0010-1

KEY	PART NUMBER	QTY	DESCRIPTION	MIXER MODEL
14	M3-1-4-0075	2	24" Incline Floor	All Models
	M3-1-4-0036	2	36" Incline Floor	All Models
	M3-1-4-0048	2	36" Incline Floor	All Models
	M3-1-4-0052	2	60" Incline Floor	All Models
	M3-1-4-0058	2	72" Incline Floor	All Models
15	830-5013-4Z	3	1/2"-13 x 4" Tap Bolt Full Threaded	All Models
16	M3-1-5-0044-1	3	Front Conveyor Bearing Mount	All Models
17	850-5013-2Z	4	1/2"-13 x 2" Carriage Bolt	All Models
18	23-0257	1	Idler Pulley	All Models
19	M3-1-5-0063-1	1	24" Front Incline Belt Conveyor, Incline Frame Weldment	All Models
	M3-1-5-0041-1	1	36" Front Incline Belt Conveyor, Incline Frame Weldment	All Models
	M3-1-5-0051-1	1	48" Front Incline Belt Conveyor, Incline Frame Weldment	All Models
	M3-1-5-0064-1	1	60" Front Incline Belt Conveyor, Incline Frame Weldment	All Models
	M3-1-5-0065-1	1	72" Front Incline Belt Conveyor, Incline Frame Weldment	All Models
20	M3-1-8-0034	1	Conveyor Motor Mount Weldment	All Models
21	M3-1-8-0006	1	Coupler Cover Plate	All Models
22	M3-1-5-0041-3	1	Incline Belt Conveyor Seal Weldment	All Models
23	49-0241	1	Incline Belt Conveyor Seal	All Models
24	VA-ICS-24	1	24" Incline Skirt Seal Kit Prior to SN 19VM(0585202, 0815202, 1015204, 1215209)	585
	M3-1-5-0063-8	2	24" Incline Skirt Backer SN 19VM(0585202, 0815202, 1015204, 1215209) & Later	All Models
	VA-ICS-36	1	36" Incline Skirt Seal Kit Prior to SN 19VM(0585201, 0815201, 1015204, 1215209)	585
	M3-1-5-0041-10	2	36" Incline Skirt Backer SN 19VM(0585202, 0815202, 1015204, 1215209) & Later	All Models
	VA-ICS-48	1	48" Incline Skirt Seal Kit Prior to SN 19VM(0585201, 0815201, 1015204, 1215209)	585
	M3-1-5-0051-8	2	48" Incline Skirt Backer SN 19VM(0585202, 0815202, 1015204, 1215209) & Later	All Models
	VA-ICS-60	1	60" Incline Skirt Seal Kit Prior to SN 19VM(0585201, 0815201, 1015204, 1215209)	585
	M3-1-5-0064-9	2	60" Incline Skirt Backer SN 19VM(0585202, 0815202, 1015204, 1215209) & Later	All Models
	VA-ICS-72	1	72" Incline Skirt Seal Kit Prior to SN 19VM(0585201, 0815201, 1015204, 1215209)	585
	M3-1-5-0065-8	2	72" Incline Skirt Backer SN 19VM(0585202, 0815202, 1015204, 1215209) & Later	All Models

FRONT INCLINE BELT CONVEYOR (CONT'D)

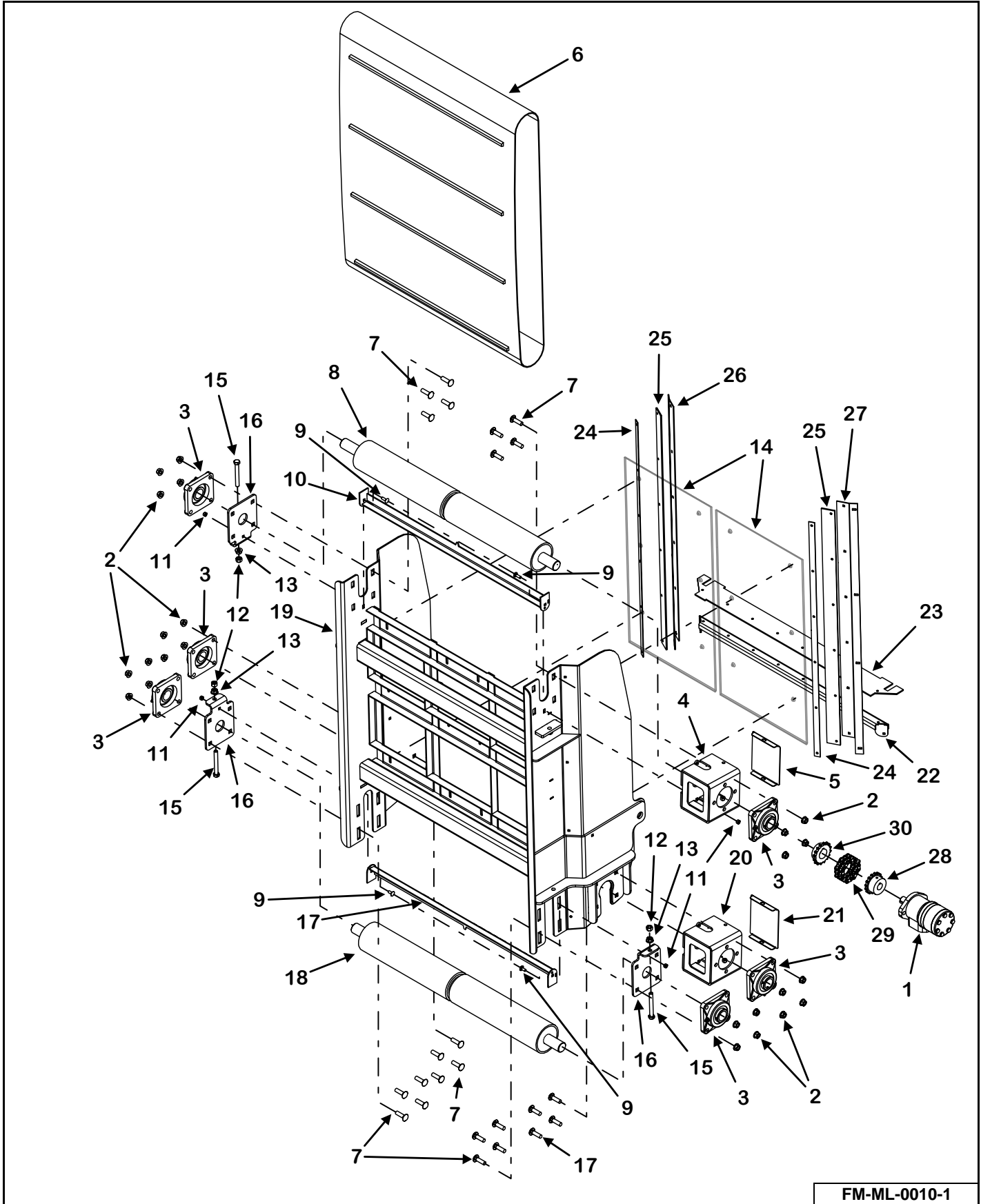

FM-ML-0010-1

KEY	PART NUMBER	QTY	DESCRIPTION	MIXER MODEL
25	VA-ICS-24	1	24" Incline Skirt Seal Kit Prior to SN 19VM(0585202, 0815202, 1015204, 1215209)	585
	49-0350	2	24" Incline Side Skirting SN 19VM(0585202, 0815202, 1015204, 1215209) & Later	All Models
	VA-ICS-36	1	36" Incline Skirt Seal Kit Prior to SN 19VM(0585201, 0815201, 1015204, 1215209)	585
	49-0348	2	36" Incline Side Skirting SN 19VM(0585202, 0815202, 1015204, 1215209) & Later	All Models
	VA-ICS-48	1	48" Incline Skirt Seal Kit Prior to SN 19VM(0585201, 0815201, 1015204, 1215209)	585
	49-0346	2	48" Incline Side Skirting SN 19VM(0585202, 0815202, 1015204, 1215209) & Later	All Models
	VA-ICS-60	1	60" Incline Skirt Seal Kit Prior to SN 19VM(0585201, 0815201, 1015204, 1215209)	585
	49-0344	2	60" Incline Side Skirting SN 19VM(0585202, 0815202, 1015204, 1215209) & Later	All Models
	VA-ICS-72	1	72" Incline Skirt Seal Kit Prior to SN 19VM(0585201, 0815201, 1015204, 1215209)	585
	49-0342	2	72" Incline Side Skirting SN 19VM(0585202, 0815202, 1015204, 1215209) & Later	All Models
26	VA-ICS-24	1	24" Incline Skirt Seal Kit Prior to SN 19VM(0585202, 0815202, 1015204, 1215209)	585
	M3-1-5-0063-7	1	24" Incline Side Skirt Bracket SN 19VM(0585202, 0815202, 1015204, 1215209) & Later	All Models
	VA-ICS-36	1	36" Incline Skirt Seal Kit Prior to SN 19VM(0585201, 0815201, 1015204, 1215209)	585
	M3-1-5-0041-9	1	36" Incline Side Skirt Bracket SN 19VM(0585202, 0815202, 1015204, 1215209) & Later	All Models
	VA-ICS-48	1	48" Incline Skirt Seal Kit Prior to SN 19VM(0585201, 0815201, 1015204, 1215209)	585
	M3-1-5-0051-7	1	48" Incline Side Skirt Bracket SN 19VM(0585202, 0815202, 1015204, 1215209) & Later	All Models
	VA-ICS-60	1	60" Incline Skirt Seal Kit Prior to SN 19VM(0585201, 0815201, 1015204, 1215209)	585
	M3-1-5-0064-8	1	60" Incline Side Skirt Bracket SN 19VM(0585202, 0815202, 1015204, 1215209) & Later	All Models
	VA-ICS-72	1	72" Incline Skirt Seal Kit Prior to SN 19VM(0585201, 0815201, 1015204, 1215209)	585
	M3-1-5-0065-7	1	72" Incline Side Skirt Bracket SN 19VM(0585202, 0815202, 1015204, 1215209) & Later	All Models

FRONT INCLINE BELT CONVEYOR (CONT'D)

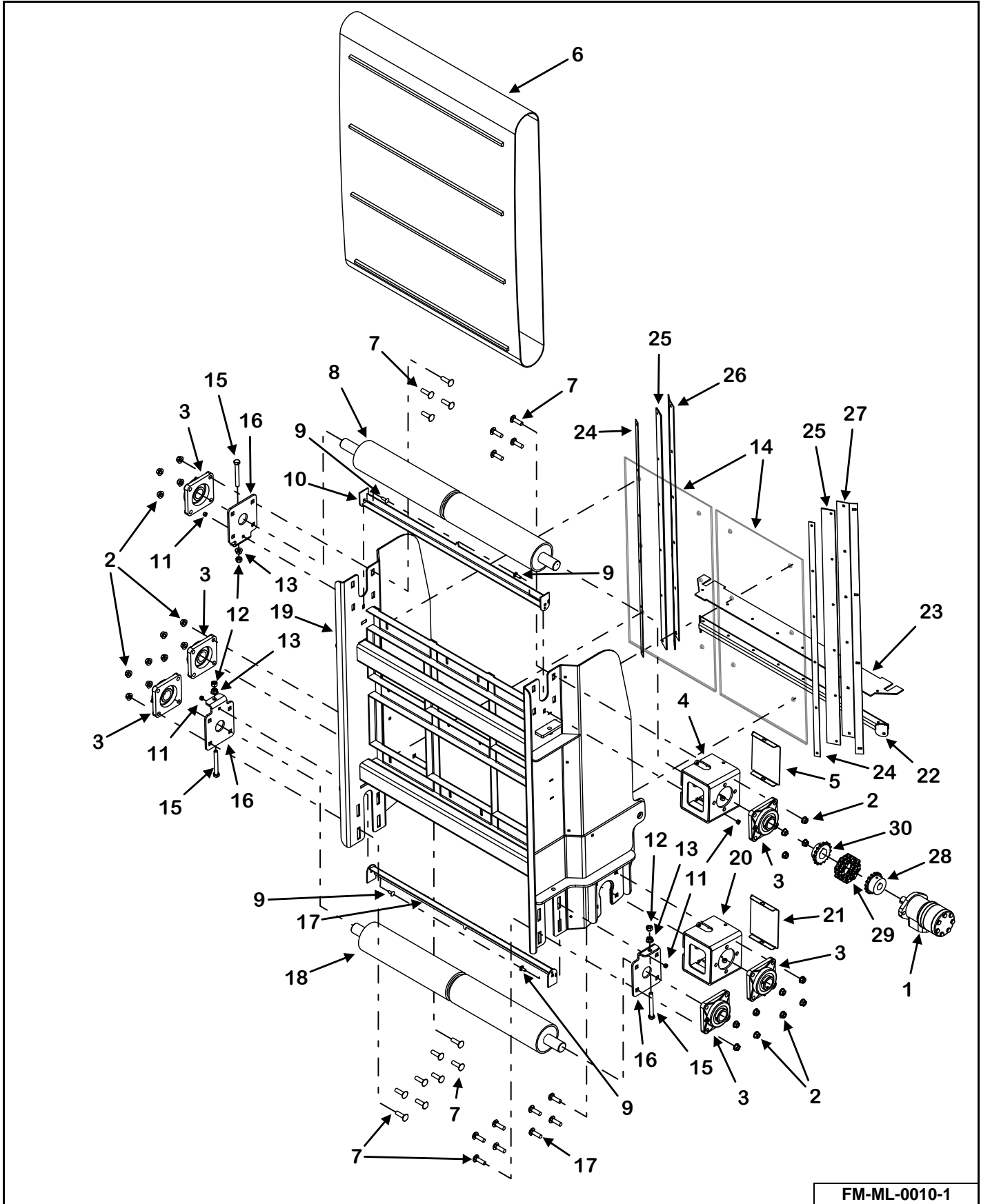

FM-ML-0010-1

KEY	PART NUMBER	QTY	DESCRIPTION	MIXER MODEL
27	VA-ICS-24	1	24" Incline Skirt Seal Kit Prior to SN 19VM(0585202, 0815202, 1015204, 1215209)	585
	M3-1-5-0063-6	1	24" Incline Side Skirt Bracket SN 19VM(0585202, 0815202, 1015204, 1215209) & Later	All Models
	VA-ICS-36	1	36" Incline Skirt Seal Kit Prior to SN 19VM(0585201, 0815201, 1015204, 1215209)	585
	M3-1-5-0041-8	1	36" Incline Side Skirt Bracket SN 19VM(0585202, 0815202, 1015204, 1215209) & Later	All Models
	VA-ICS-48	1	48" Incline Skirt Seal Kit Prior to SN 19VM(0585201, 0815201, 1015204, 1215209)	585
	M3-1-5-0051-6	1	48" Incline Side Skirt Bracket SN 19VM(0585202, 0815202, 1015204, 1215209) & Later	All Models
	VA-ICS-60	1	60" Incline Skirt Seal Kit Prior to SN 19VM(0585201, 0815201, 1015204, 1215209)	585
	M3-1-5-0064-7	1	60" Incline Side Skirt Bracket SN 19VM(0585202, 0815202, 1015204, 1215209) & Later	All Models
	VA-ICS-72	1	72" Incline Skirt Seal Kit Prior to SN 19VM(0585201, 0815201, 1015204, 1215209)	585
	M3-1-5-0065-6	1	72" Incline Side Skirt Bracket SN 19VM(0585202, 0815202, 1015204, 1215209) & Later	All Models
28	37-0013-1	1	Coupler Sprocket	All Models
29	37-0013-2	1	Coupler Chain	All Models
30	110-50B16-1.50-1	1	Coupler Sprocket	All Models
	35-0006	1	Key	All Models

FRONT LH INCLINE BELT CONVEYOR HYDRAULIC SCHEMATIC

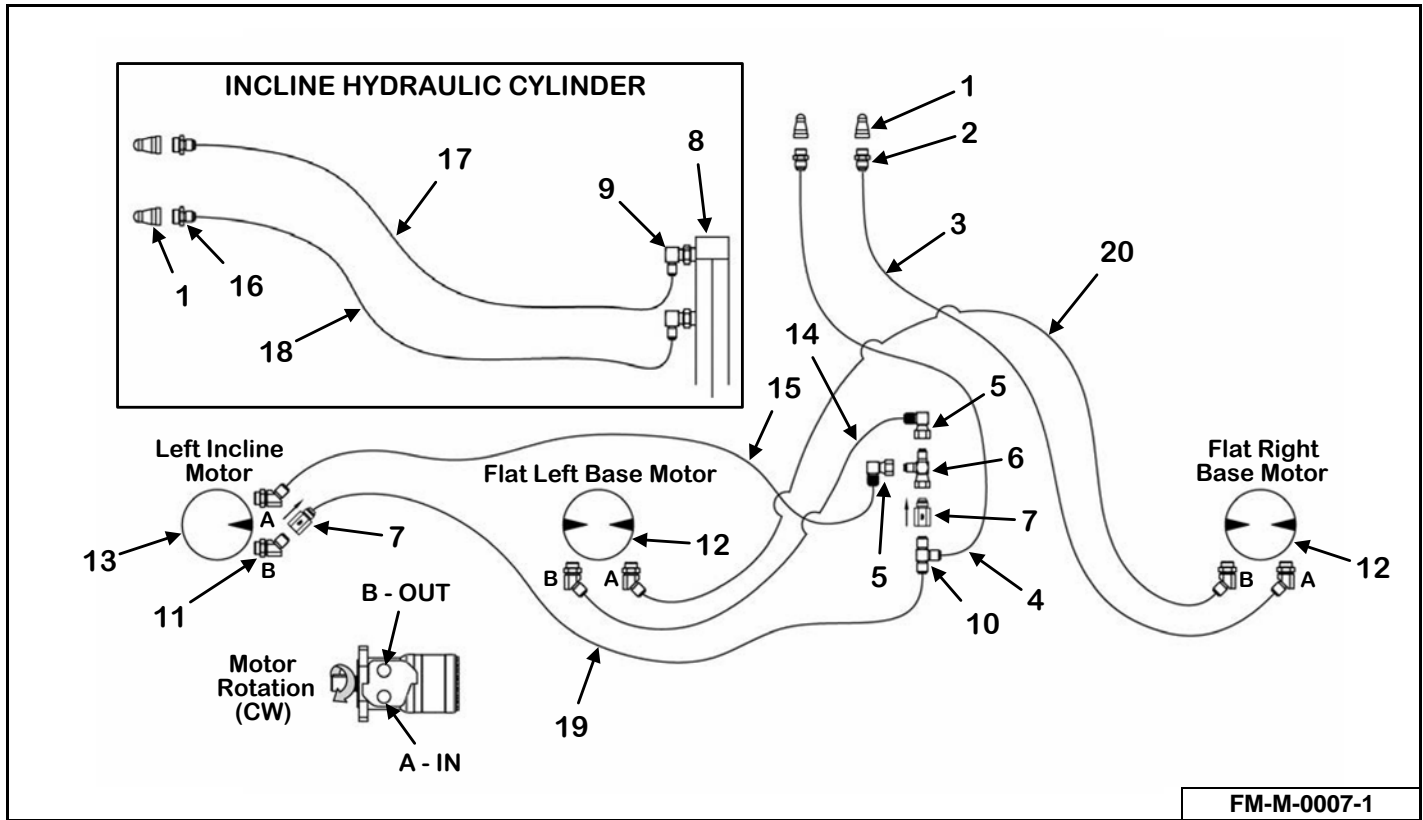

FRONT RH INCLINE BELT CONVEYOR HYDRAULIC SCHEMATIC

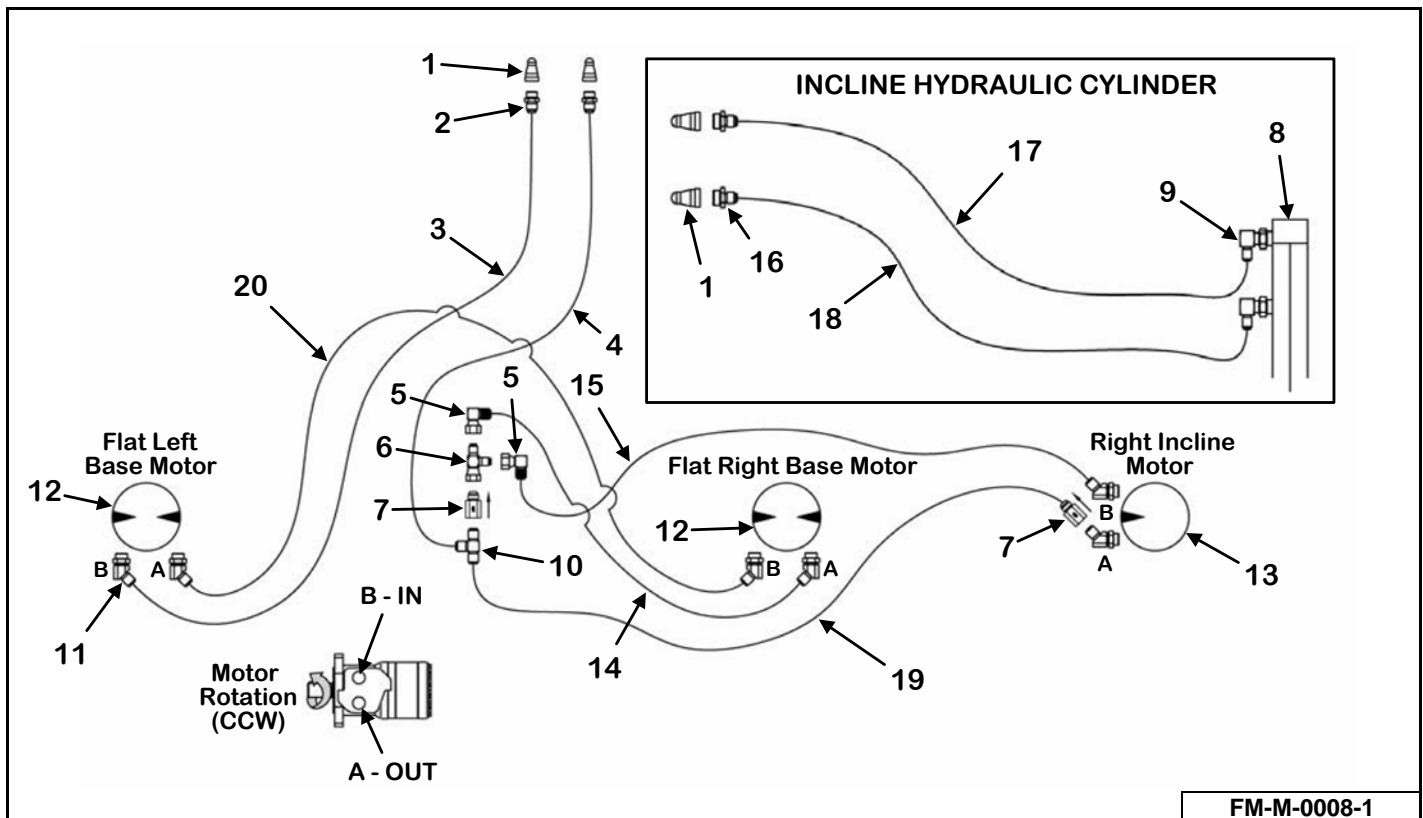

KEY	PART NUMBER	QTY	DESCRIPTION	MIXER MODEL
1	155-8010-15	4	#8 ORB Male Tip 1/2" Body Size	All Models
2	155-6400-8-8	2	#8 JIC Male, #8 ORB Male Straight Connector	All Models
3	155-08R17-189-1	1	1/2" x 189" Hose Assembly	All Models
4	155-08R17-159-1	1	1/2" x 159" Hose Assembly	585/700
	155-08R17-166-1	1	1/2" x 166" Hose Assembly	F2-585/F2-700
5	155-6500-08-08	1	#8 JIC Male, #8 JIC Female Swivel 90°	All Models
6	155-6602-08-08-08	1	#8 MJ x #8 FJS x #8 MJ Tee	All Models
7	155-CV-8-1	2	Check Valve	All Models
8	155-2-16-1.125-2	1	2" x 16" x 1-1/8" Hydraulic Cylinder	All Models
	155-2-1.125-1-DSK	1	Cylinder Seal Kit	All Models
9	155-6801-6-8-55	2	#6 x #8 90° Adjustable Elbow with 0.055" Orifice	All Models
10	155-2603-08-08-08	1	#8 x #8 x #8 JIC Male Tube Tee	All Models
11	155-6802-8-10	6	#8 JIC Male, #10 ORB Male Adjustable 45°	All Models
12	155-WR-12.1-1	2	12.1 Cubic Inch 2-Bolt Motor	All Models
	155-WR-SK-1	AR	Motor Seal Kit	All Models
13	155-WR-7.9-1	1	7.9 Cubic Inch 2-Bolt Motor	All Models
	155-WR-SK-1	AR	Motor Seal Kit	All Models
14	155-08R17-57-1	1	1/2" x 57" Hose Assembly	All Models
15	155-08R17-69-1	1	1/2" x 69" Hose Assembly (24" Incline)	All Models
	155-08R17-75-1	1	1/2" x 75" Hose Assembly (36" Incline)	All Models
	155-08R17-87-1	1	1/2" x 87" Hose Assembly (48" Incline)	All Models
	155-08R17-99-1	1	1/2" x 99" Hose Assembly (60" Incline)	All Models
16	155-6400-6-8	2	#6 x JIC Male Tube #8 ORB Male Straight Connector	All Models
17	155-04R17-121-1	1	1/4" x 121" Hose Assembly	585/700
	155-04R17-108-1	1	1/4" x 108" Hose Assembly	F2-585/F2-700
18	155-04R17-102-1	1	1/4" x 102" Hose Assembly	585/700
	155-04R17-126-1	1	1/4" x 126" Hose Assembly	F2-585/F2-700
19	155-08R17-61-1	1	1/2" x 61" Hose Assembly (24" Incline)	All Models
	155-08R17-69-1	1	1/2" x 69" Hose Assembly (36" Incline)	All Models
	155-08R17-81-1	1	1/2" x 81" Hose Assembly (48" Incline)	All Models
	155-08R17-93-1	1	1/2" x 93" Hose Assembly (60" Incline)	All Models
20	155-08R17-166-1	1	1/2" x 166" Hose Assembly	All Models

FRONT INCLINE BELT CONVEYOR STOP

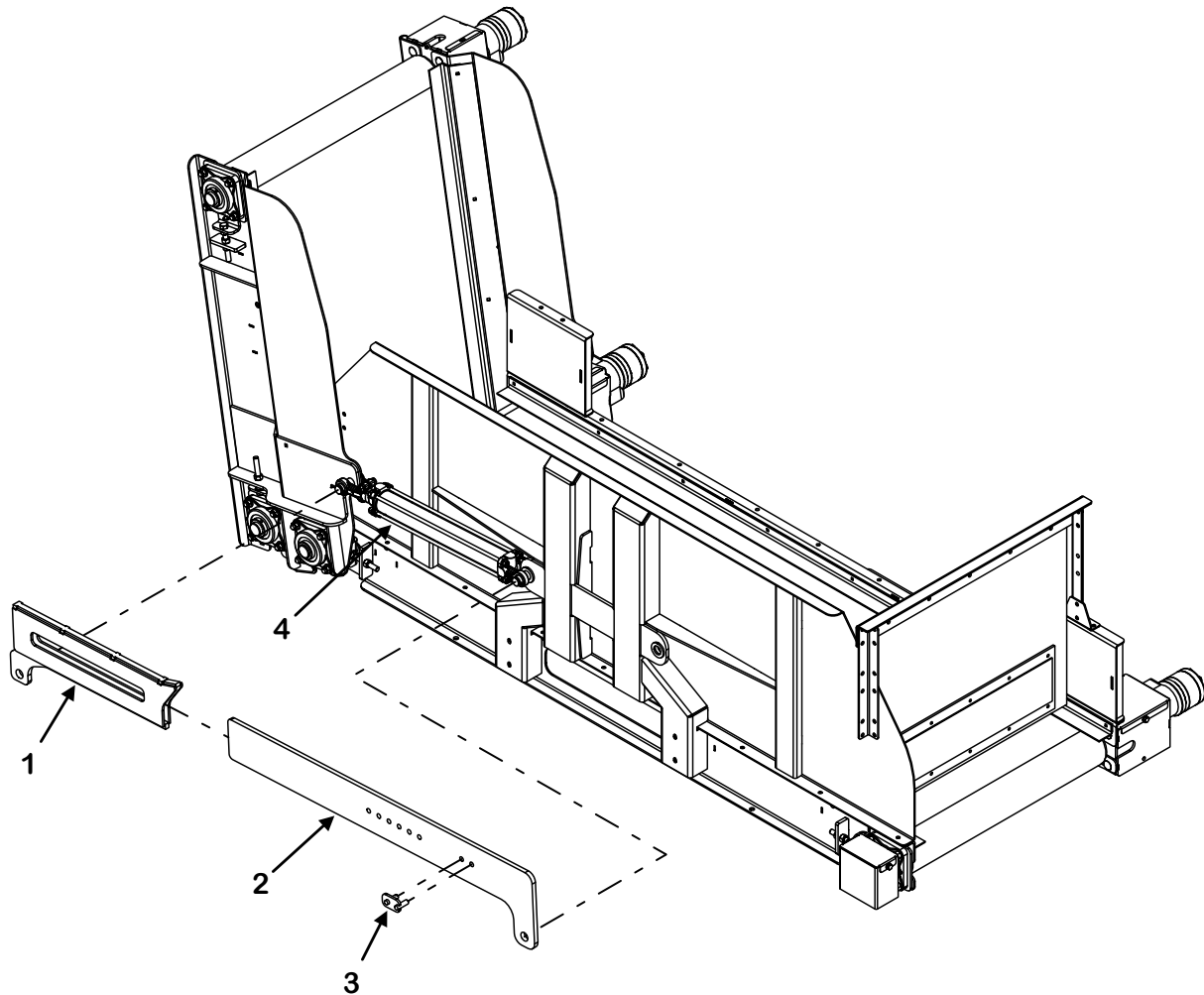

FM-ML-0013-1

KEY	PART NUMBER	QTY	DESCRIPTION	MIXER MODEL
0	VA-IBCS	1	Incline Belt Conveyor Stop	All Models
1	M3-1-5-0070	1	Incline Conveyor Stop Slider Weldment	All Models
2	M3-1-5-0052	1	Incline Conveyor Stop Bar	All Models
3	M3-1-5-0055	1	Belt Conveyor Stop Weldment	All Models
	32-0019	1	Hair Spring Cotter Pin	All Models
4	See Page 118	1	2" x 16" x 1-1/8" Hydraulic Cylinder	All Models

FRONT FLAT & INCLINE CHAIN CONVEYOR ASSEMBLY

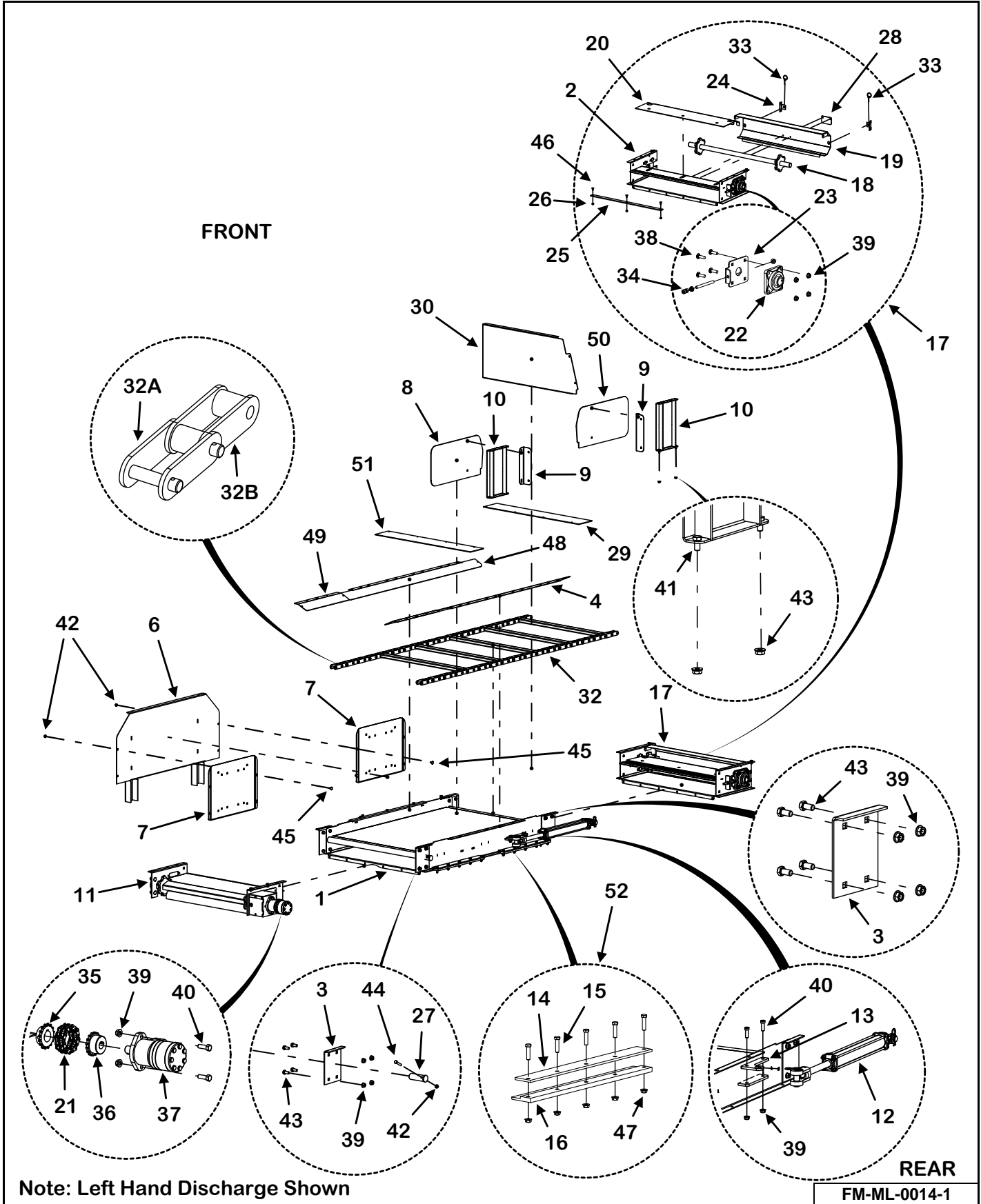

KEY	PART NUMBER	QTY	DESCRIPTION	MIXER MODEL
1	M3-1-5-0001-1	1	Front Conveyor-Center Section Weldment, Flat	All Models
2	M3-1-5-0002-1	1	Front Conveyor Panel Weldment	All Models
3	M3-1-7-0014	4	Front Conveyor Connecting Plate	All Models
4	M3-1-5-0022	1	Conveyor Chain Cover, Flat (LH Discharge-Rear, RH Discharge-Front)	All Models
5	M3-1-5-0012	1	Conveyor Chain Cover, Flat (LH Discharge-Rear, RH Discharge-Front)	All Models
6	M3-1-5-0009	1	Front Conveyor Panel Weldment	All Models
7	M3-1-5-0010	2	Front Conveyor Panel	All Models
8	M3-1-7-0024	2	Front Conveyor Shield, Flat	All Models
	M3-1-7-0028	1	Front Conveyor Shield, Incline (Left Discharge)	All Models
9	M3-1-7-0021	2	Front Shield Mounting Bracket	All Models
10	M3-1-7-0023	2	Conveyor Shield Assembly	All Models
11	See Page 128	1	Front Flat & Incline Conveyor Assembly	All Models
12	See Page 130	1	Hydraulic Cylinder	All Models
	33-0309	1	Cylinder Pin Spacer, Flat & Incline	All Models
13	M3-1-8-0011	1	Front Conveyor Cylinder Mount	All Models
14	VAM-CSK	1	Conveyor Slide Update Kit (Flat Sliding Conveyor Only) Prior to SN 20VM(0585211, 0700204)	585/700
	M3-1-7-0057	4	Conveyor Slide Cap (Flat Sliding Conveyor Only) SN 20VM(0585211, 0700204) & Later	All Models
15	851-3816-1.5Z	20	3/8"-16 x 1-1/2" Hex Cap Screw	All Models

FRONT FLAT & INCLINE CHAIN CONVEYOR ASSEMBLY (CONT'D)

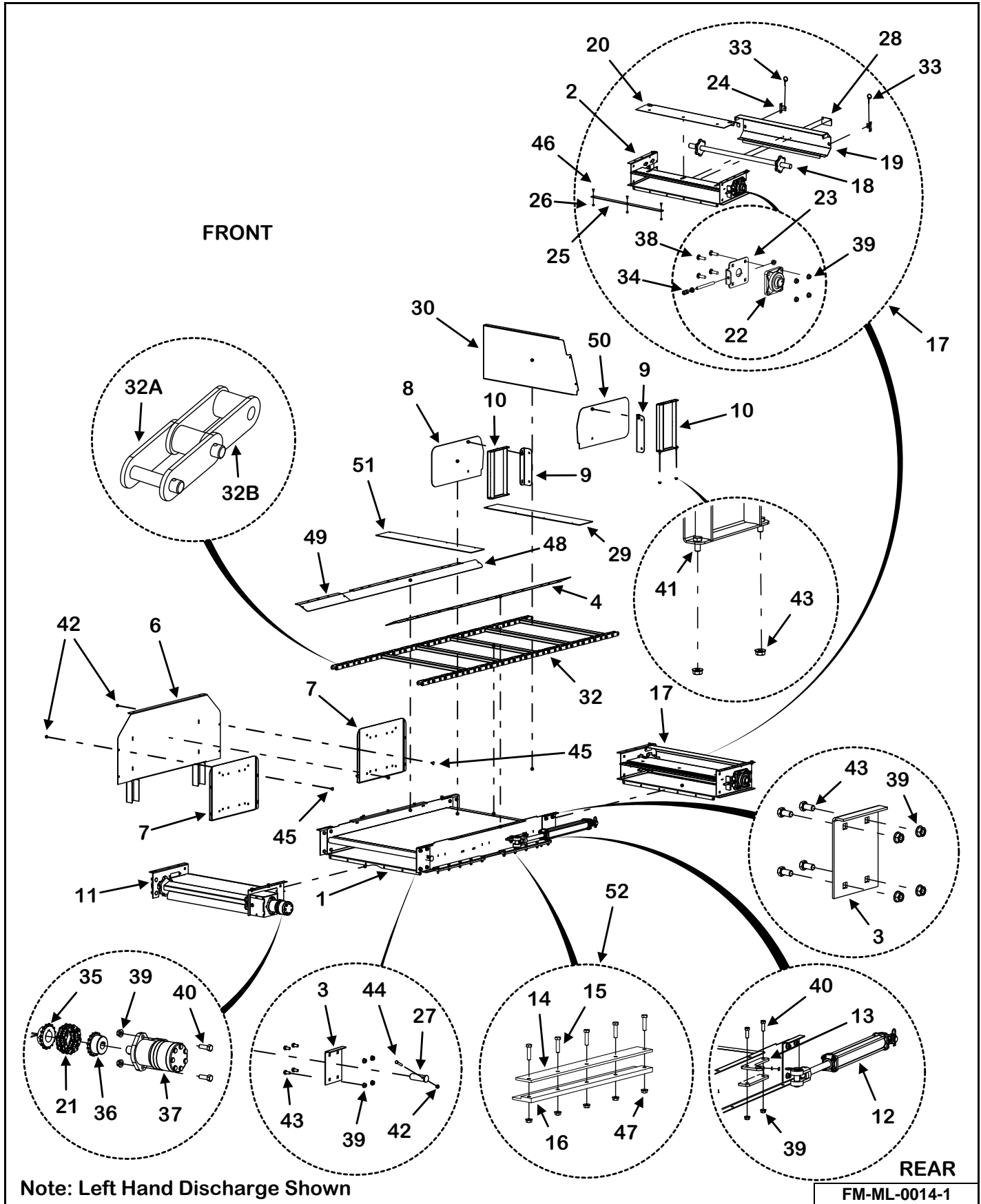

KEY	PART NUMBER	QTY	DESCRIPTION	MIXER MODEL
16	VAM-CSK	1	Conveyor Slide Update Kit (Flat Sliding Conveyor Only) Prior to SN 20VM(0585211, 0700204)	585/700
	M3-1-7-0056	4	Conveyor Bottom Slide (Flat Sliding Conveyor Only) SN 20VM(0585211, 0700204) & Later	All Models
17	M3-1-5-0002	1	Front Conveyor Extension Assembly	All Models
18	23-0255	1	Conveyor Idler Shaft Assembly	All Models
19	M3-1-7-0005-1-AS	1	Conveyor Extension Chain Guard	All Models
	M3-1-7-0005-3	2	Conveyor Clean-Out Door Washer	All Models
20	M3-1-7-0013	1	Extension Sprocket Cover	All Models
21	37-0013-2	1	Unit Coupler Chain #50 16 Double W/Connector	All Models
22	14-0070	4	1-1/2" 4 Bolt Bearing	All Models
23	M3-1-8-0002	2	Front Conveyor Bearing Mount	All Models
24	M3-1-7-0034	2	Conveyor Extension Cover Latch	All Models
25	M3-1-4-0029	1	36" Extension Adjustment Bracket Weldment	All Models
26	813-3118	3	5/16"-18 Hex Nut Plain	All Models
27	M3-1-5-0004-2	2	Hinge Pin, Incline	All Models
28	M3-1-7-0005-2	1	Conveyor Extension Cover Handle	All Models
29	49-0184	1	Front Left Discharge Conveyor Chain Cover, Incline	All Models
30	M3-1-7-0011	1	Conveyor Cross Panel – Incline, LH	All Models
	M3-1-7-0027	1	Conveyor Cross Panel – Incline, RH	All Models
31	830-5013-4Z	2	Tap Bolt, 1/2"-13 x 4"	All Models
32	11-0505	1	Front Discharge, 36" Flat Conveyor 81x Chain	All Models
32A	11-0272-4	AR	81X Connector Link	All Models
32B	11-0272-5	AR	81X Offset Link	All Models
33	823-0003	2	Lynch Pin 3/16" x 1-1/4"	All Models
34	813-5013-Z	4	1/2"-13 Nut	All Models
35	110-50B16-1.50-1	1	Chain Coupler Sprocket 1.5 Bore x .375" Keyway	All Models
36	37-0013-1	1	Unit Coupler 1" Bore 1/4" Keyway	All Models
	135-2525-1.25-1	1	1/4" x 1/4" x 1-1/4" Key	All Models

FRONT FLAT & INCLINE CHAIN CONVEYOR ASSEMBLY (CONT'D)

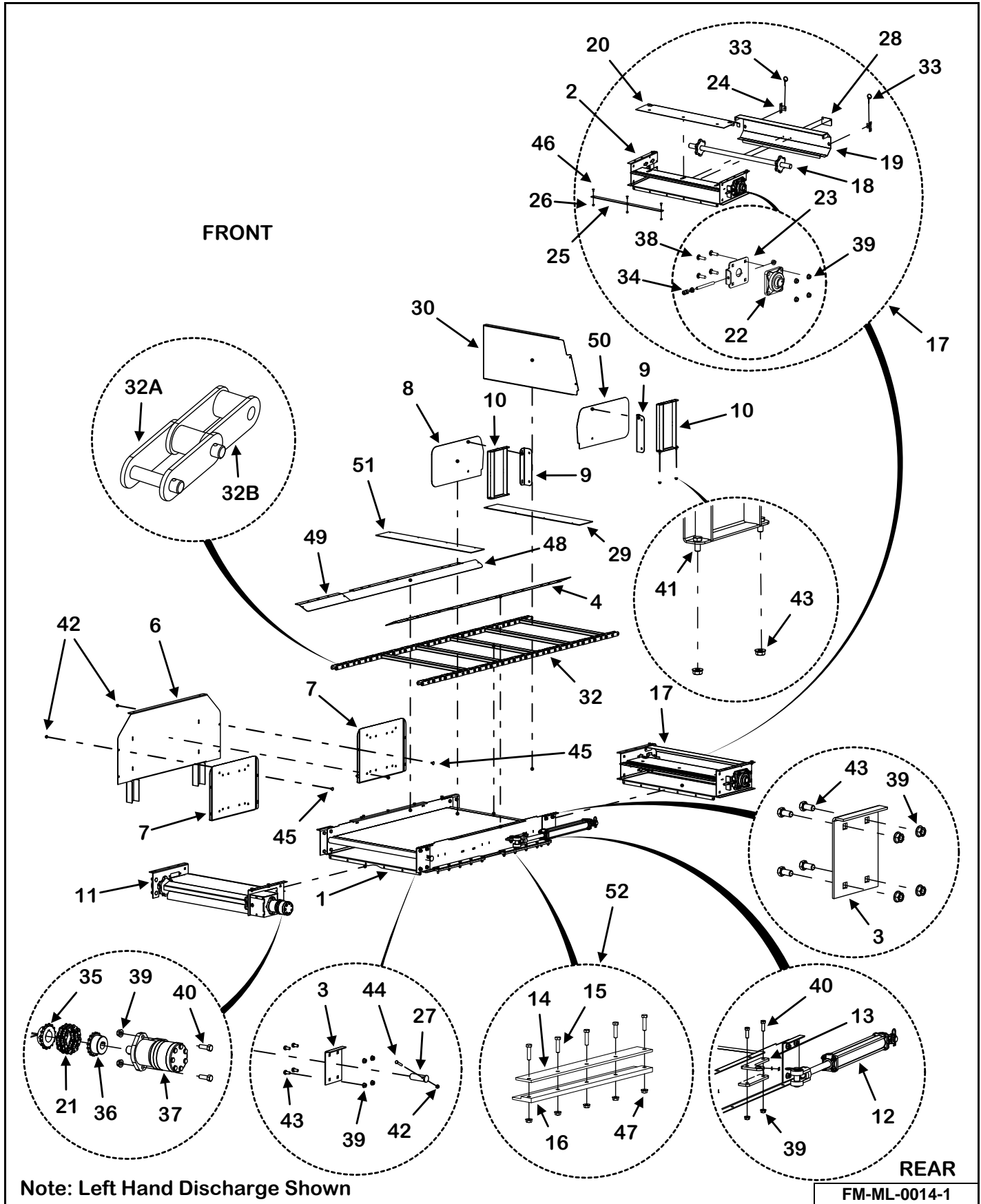

KEY	PART NUMBER	QTY	DESCRIPTION	MIXER MODEL
37	See Page 130	1	12.1 Cubic Inch 2-Bolt Motor	All Models
38	850-5013-1.75Z	16	1/2"-13 x 1-3/4" Carriage Bolt, Grade 5	All Models
39	810-5013-Z	28	1/2" Spin Lock Nut	All Models
40	851-5013-1.5Z	4	1/2"-13 x 1-1/2" Bolt	All Models
41	851-3816-.75Z	4	3/8"-16 x 3/4" Grade 5 Machine Bolt	All Models
42	810-3816-Z	10	3/8" Spin Lock Nut	All Models
43	851-5013-1Z	16	1/2"-13 x 1" Bolt	All Models
44	851-3816-2Z	2	3/8"-16 x 2" Grade 5 Machine Bolt	All Models
45	850-3816-.75Z	4	3/8"-16 x 3/4" Grade 5 Carriage Bolt	All Models
46	803-3118-.75Z	3	5/16"-18 x 3/4" Flat Head Socket Cap Screw	All Models
47	810-3816-Z	20	3/8"-16 Spin Lock Nut	All Models
48	M3-1-5-0028	1	Conveyor Chain Cover, Flat (LH Discharge-Front, RH Discharge-Rear)	All Models
49	M3-1-5-0029	1	Conveyor Chain Cover, Flat Extension (LH Discharge- Front, RH Discharge-Rear)	All Models
50	M3-1-7-0024	1	Front Conveyor Shield, Flat	All Models
	M3-1-7-0028	1	Front Conveyor Shield, Incline (Right Discharge)	All Models
51	49-0185	1	Front Right Discharge Conveyor Chain Cover, Incline	All Models
52	VAM-CSK	1	Conveyor Slide Update Kit (Flat Sliding Conveyor Only) Prior to SN 20VM(0585211, 0700204)	585/700
	M3-1-7-0056-AS	4	Conveyor Bottom Slide With Cap & Hardware (Flat Sliding Conveyor Only) SN 20VM(0585211, 0700204)& Later	All Models

FRONT FLAT CONVEYOR

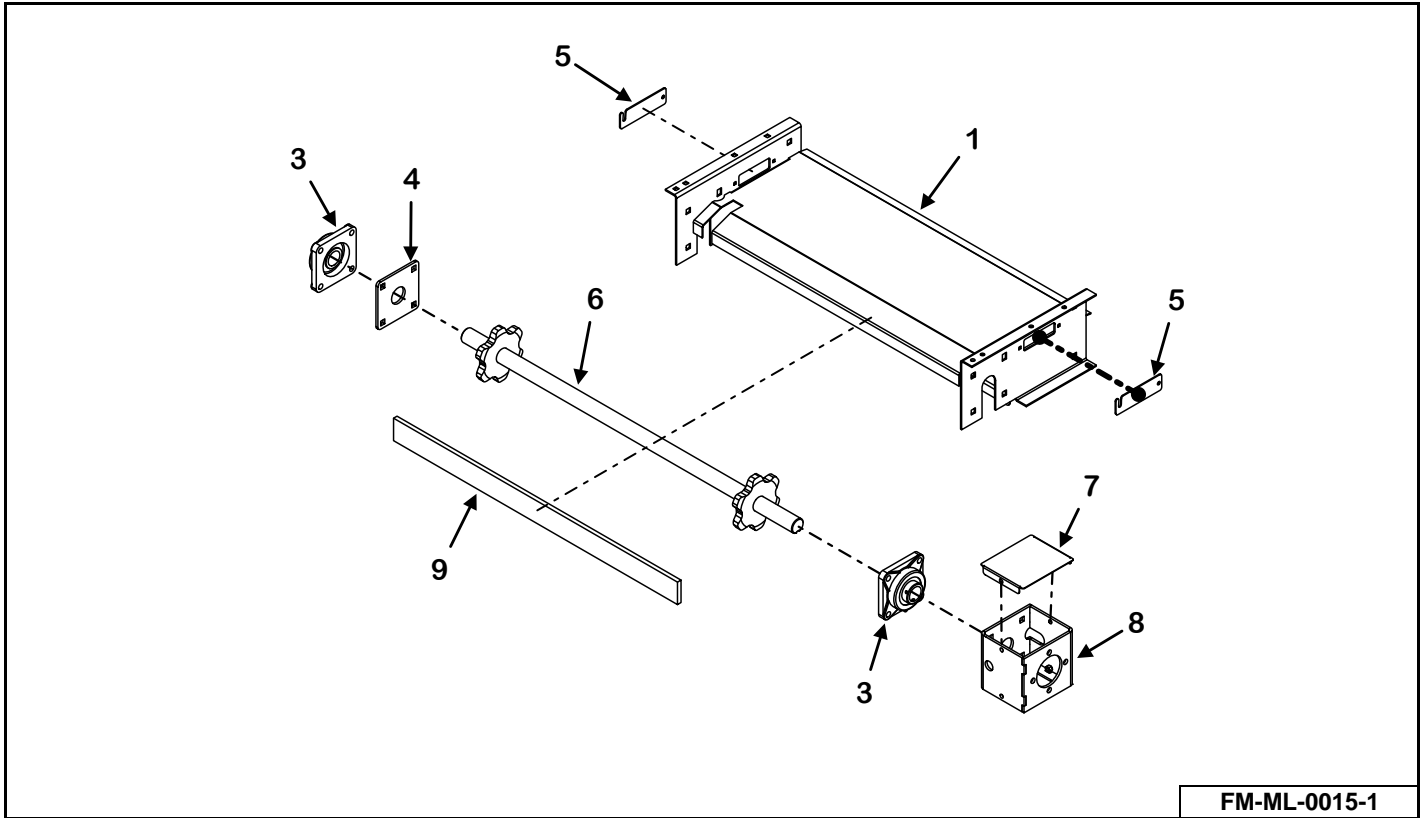

FM-ML-0015-1

FRONT INCLINE CONVEYOR

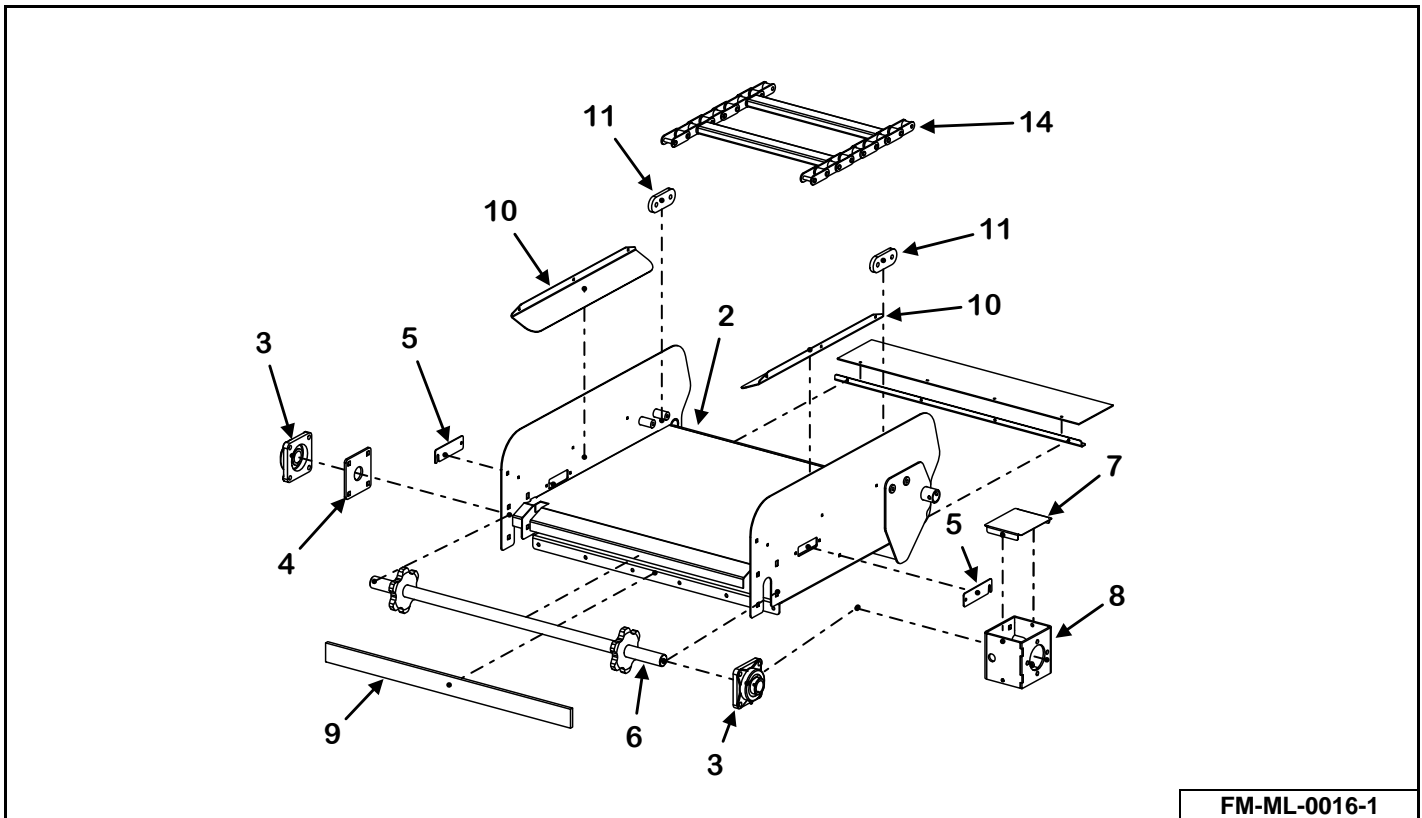

FM-ML-0016-1

KEY	PART NUMBER	QTY	DESCRIPTION	MIXER MODEL
0	M3-1-5-0003	1	36" Wide Front Flat Drive End Assembly	All Models
	VAM-DCI-36-I24	1	Front Incline Conveyor Assembly (36" x 24" Conveyor)	All Models
	VAM-DCI-36-I36	1	Front Incline Conveyor Assembly (36" x 36" Conveyor)	All Models
	VAM-DCI-36-I48	1	Front Incline Conveyor Assembly (36" x 48" Conveyor)	All Models
	VAM-DCI-36-I60	1	Front Incline Conveyor Assembly (36" x 60" Conveyor)	All Models
1	M3-1-5-0003-1	1	36" Front Conveyor Ext Weldment-Flat Drive End	All Models
2	M3-1-5-0032-1	1	Front Incline Conveyor Weldment (36" x 24" Conveyor)	All Models
	M3-1-5-0033-1	1	Front Incline Conveyor Weldment (36" x 36" Conveyor)	All Models
	M3-1-5-0034-1	1	Front Incline Conveyor Weldment (36" x 48" Conveyor)	All Models
	M3-1-5-0036-1	1	Front Incline Conveyor Weldment (36" x 60" Conveyor)	All Models
3	14-0070	4	1-1/2" 4-Bolt Bearing	All Models
4	M3-1-4-0002	1	Extension Bearing Mount Plate	All Models
5	M3-1-4-0015-2	2	Chute Cover	All Models
6	23-0254	1	36" Wide Conveyor Drive Shaft Weldment, Flat	All Models
	23-0262	1	36" Wide Conveyor Drive Shaft Weldment, Incline	All Models
7	M3-1-8-0006	1	Coupler Cover Plate	All Models
8	M3-1-8-0034	1	Front Conveyor Motor Bracket	All Models
9	49-0181	1	Front Chain Conveyor Belt	All Models
10	M3-1-5-0011-2	2	Conveyor Chain Cover, Incline (24" Conveyor)	All Models
	M3-1-5-0025	2	Conveyor Chain Cover, Incline (36" Conveyor)	All Models
	M3-1-5-0014	2	Conveyor Chain Cover, Incline (48" Conveyor)	All Models
	M3-1-4-0045-2	2	Conveyor Chain Cover, Incline (60" Conveyor)	All Models
11	M3-1-7-0006	2	Chain Hold Down Plate	All Models
12	850-5013-1.75Z	8	1/2"- 13 x 1-3/4" Carriage Bolt, Grade 5	All Models
13	810-5013-Z	8	1/2" Spin Lock Nut	All Models
14	11-0501-AS	1	Incline Ext. 81X Chain Assembly (36" x 24" Conveyor)	All Models
	11-0508	1	Incline Ext. 81X Chain Assembly (36" x 36" Conveyor)	All Models
	11-0509	1	Incline Ext. 81X Chain Assembly (36" x 48" Conveyor)	All Models
	11-0510	1	Incline Ext. 81X Chain Assembly (36" x 60" Conveyor)	All Models

FLAT CHAIN CONVEYOR HYDRAULIC SCHEMATIC

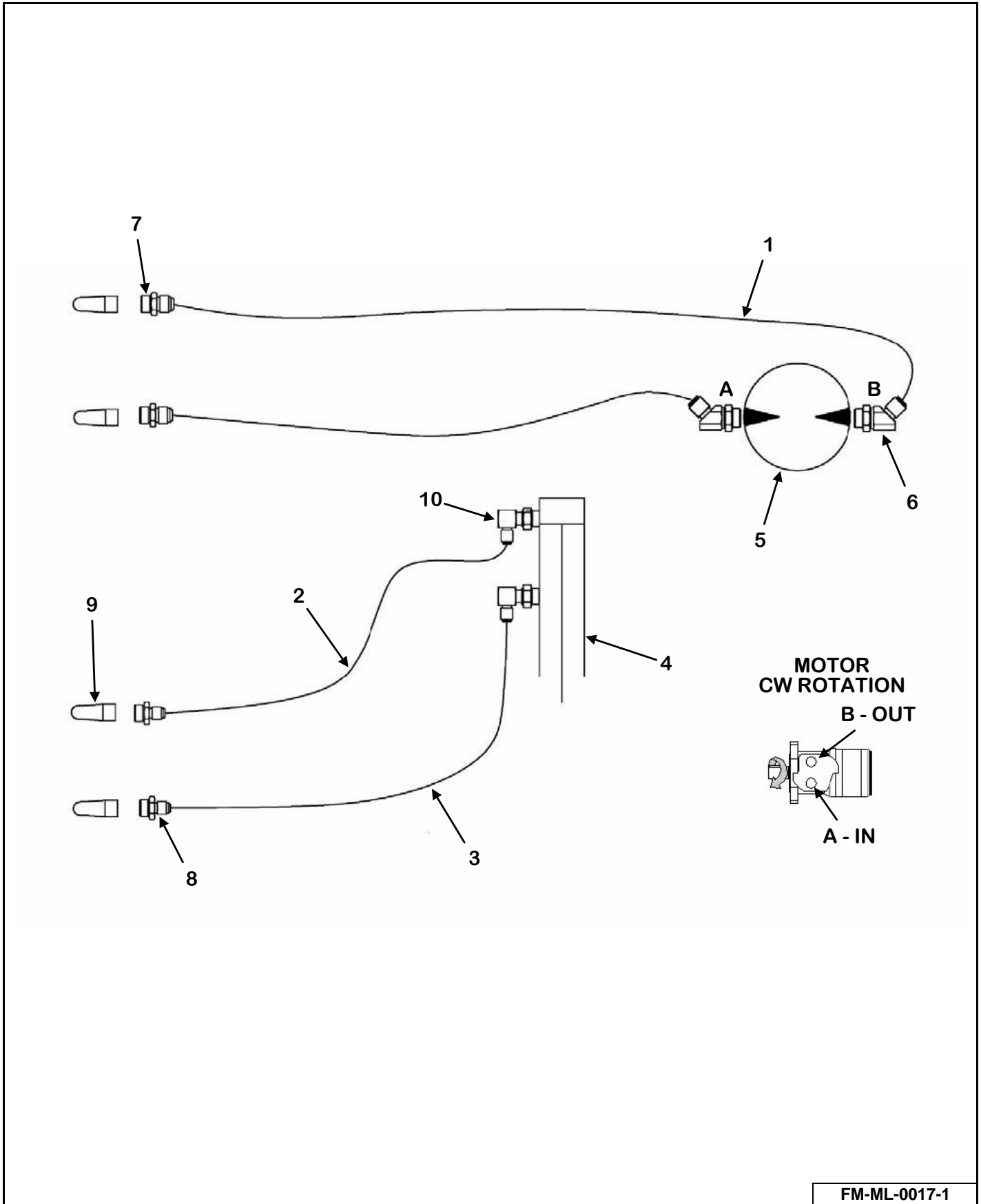

KEY	PART NUMBER	QTY	DESCRIPTION	MIXER MODEL
1	155-08R17-189-1	2	1/2" x 189" Hose Assembly	All Models
2	155-04R17-173-1	1	1/4" x 173" Hose Assembly	All Models
3	155-04R17-185-1	1	1/4" x 185" Hose Assembly	All Models
4	155-2-16-1.125-2	1	2" x 16" x 1-1/8" Hydraulic Cylinder	All Models
5	155-WR-12.1-1	1	12.1 Cubic Inch 2-Bolt Motor	All Models
	155-WR-SK-1	1	Motor Seal Kit	All Models
6	155-6802-8-10	2	#8 JIC Male, #10 ORB Male Adjustable 45°	All Models
7	155-6400-8-8	2	#8 JIC Male, #8 ORB Male Straight Connector	All Models
8	155-6400-6-8	2	#6 JIC Male, #8 ORB Male Straight Connector	All Models
9	155-8010-15	4	#8 ORB Male Tip 1/2" Body Size	All Models
10	155-6801-6-8	2	#6 JIC Male, #8 ORB Male Adjustable 90°	All Models

FRONT DISCHARGE INCLINE CHAIN CONVEYOR HYDRAULIC SCHEMATIC

MODELS: (36" X 24" CHAIN CONVEYOR)

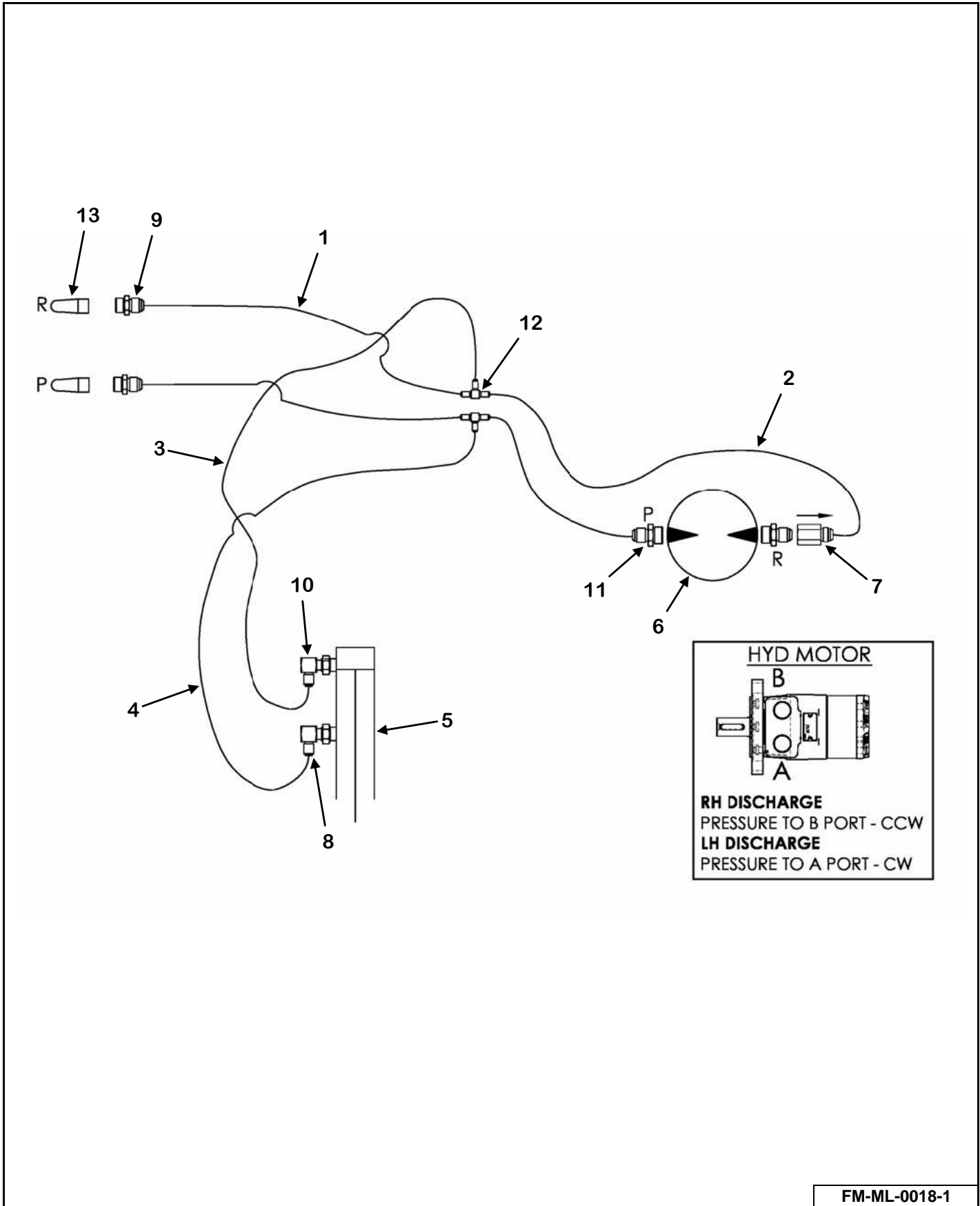

FM-ML-0018-1

KEY	PART NUMBER	QTY	DESCRIPTION	MIXER MODEL
1	155-08R17-138-1	2	1/2" x 138" Hose Assembly (36" x 24" Conveyor Chain)	585/700
	155-08R17-141-1	2	1/2" x 141" Hose Assembly (36" x 24" Conveyor Chain)	F2-585/F2-700
2	155-08R17-69-1	2	1/2" x 69" Hose Assembly (36" x 24" Conveyor Chain)	All Models
3	155-04R17-19-1	1	1/4" x 19" Hose Assembly (36" x 24" Conveyor Chain)	All Models
4	155-04R17-28-1	1	1/4" x 28" Hose Assembly (36" x 24" Conveyor Chain)	All Models
5	155-2-8-1.125-1	1	2" x 8" x 1-1/8" Hydraulic Cylinder	All Models
6	155-WR-12.1-1	1	12.1 Cubic Inch 2-Bolt Motor	All Models
	155-WR-SK-1	1	Motor Seal Kit	All Models
7	155-CV-8-1	1	Check Valve	All Models
8	155-6801-6-8	1	#6 JIC Male, #8 ORB Male Adjustable 90°	585/700
	155-6801-6-8-55	1	#6 x #8 90° Adj Elbow With .055" Orifice	F2-585/F2-700
9	155-6400-8-8	2	#8 JIC Male, #8 ORB Male Straight Connector	All Models
10	155-6801-6-8-55	1	#6 x #8 90° Adj Elbow With .055" Orifice	All Models
11	155-6400-08-10	2	#8 JIC Male, #10 ORB Male Straight Connector	585/700
	155-6802-8-10	2	#8 JIC Male, #10 ORB Male Adjustable 45°	F2-585/F2-700
12	155-2603-08-08-06	2	#8 x #8 x #8 JIC Male Tube Tee	All Models
13	155-8010-15	2	#8 ORB Male Tip 1/2" Body Size	All Models

FRONT DISCHARGE INCLINE CHAIN CONVEYOR HYDRAULIC SCHEMATIC
MODELS 585 - 1215: (36" X 36", 36" X 48", 36" X 60" CHAIN CONVEYOR)

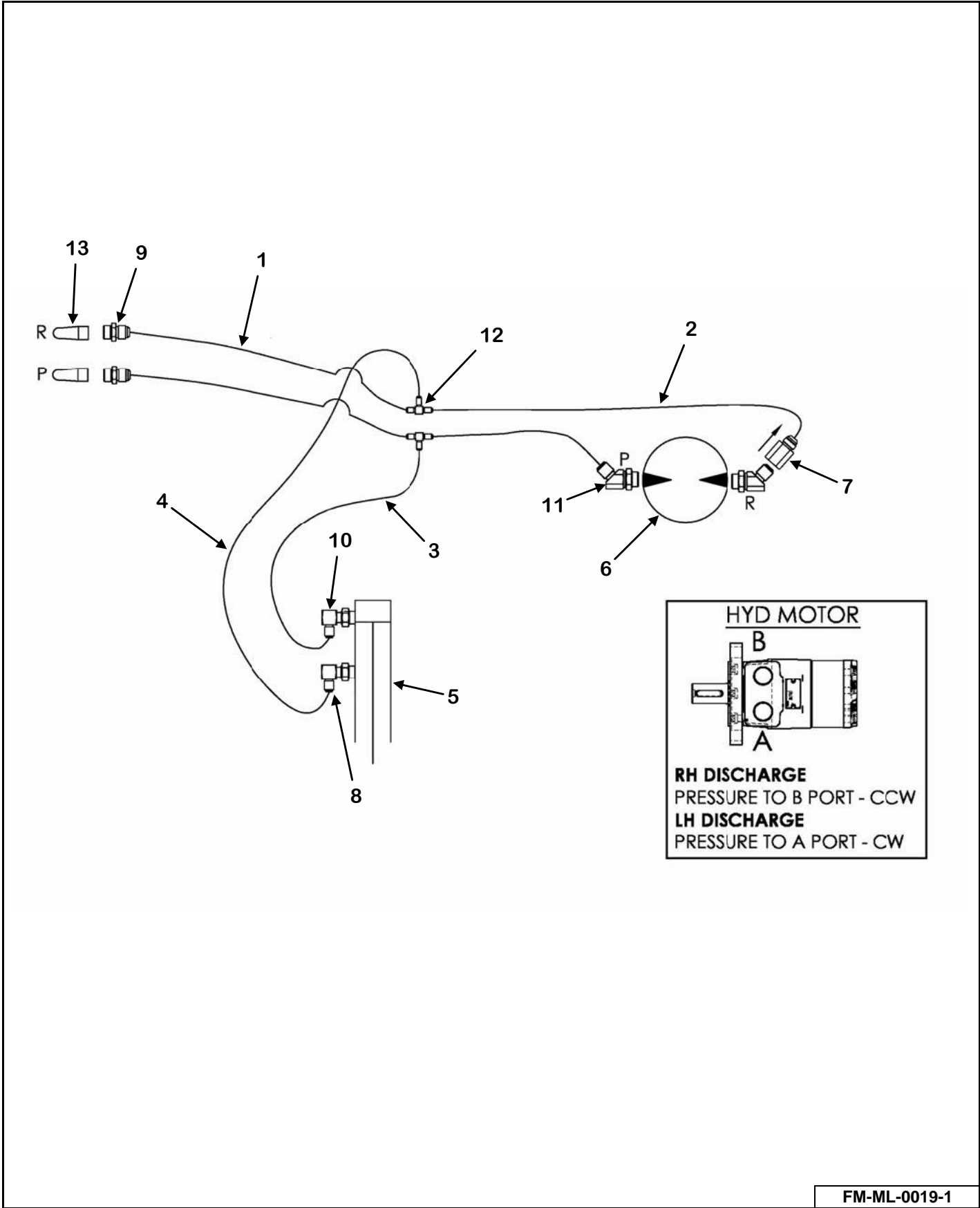

FM-ML-0019-1

KEY	PART NUMBER	QTY	DESCRIPTION	MIXER MODEL
1	155-08R17-138-1	2	1/2" x 138" Hose Assembly (36" x 36", 36" x 48", 36" x 60" Conveyor Chain)	585/700
	155-08R17-141-1	2	1/2" x 141" Hose Assembly (36" x 24" Conveyor Chain)	F2-585/F2-700
2	155-08R17-85-1	2	1/2" x 85" Hose Assembly (36" x 36" Conveyor Chain)	All Models
	155-08R17-97-1	2	1/2" x 97" Hose Assembly (36" x 48" Conveyor Chain)	All Models
	Call 1-800-325-9103	2	1/2" x _" Hose Assembly (36" x 60" Conveyor Chain)	All Models
3	155-04R17-19-1	1	1/4" x 19" Hose Assembly (36" x 36", 36" x 48", 36" x 60" Conveyor Chain)	All Models
4	155-04R17-28-1	1	1/4" x 28" Hose Assembly (36" x 36", 36" x 48", 36" x 60" Conveyor Chain)	All Models
5	155-2-8-1.125-1	1	2" x 8" x 1-1/8" Hydraulic Cylinder	All Models
6	155-WR-12.1-1	1	12.1 Cubic Inch 2-Bolt Motor	All Models
	155-WR-SK-1	1	Motor Seal Kit	All Models
7	155-CV-8-1	1	Check Valve	All Models
8	155-6801-6-8	1	#6 JIC Male, #8 ORB Male Adjustable 90°	585/700
	155-6801-6-8-55	1	#6 x #8 90° Adj Elbow With .055" Orifice	F2-585/F2-700
9	155-6400-8-8	2	#8 JIC Male, #8 ORB Male Straight Connector	All Models
10	155-6801-6-8-55	1	#6 x #8 90° Adj Elbow With .055" Orifice	All Models
11	155-6802-8-10	2	#8 JIC Male, #10 ORB Male Adjustable 45°	All Models
12	155-2603-08-08-06	2	#8 x #8 x #8 JIC Male Tube Tee	All Models
13	155-8010-15	2	#8 ORB Male Tip 1/2" Body Size	All Models

KEY	PART NUMBER	QTY	DESCRIPTION	MIXER MODEL
0	VAM-DBI-42-24-SL	1	42" x 24" Left Side Belt Conveyor Complete	All Models
	VAM-DBI-42-24-SR	1	42" x 24" Right Side Belt Conveyor Complete	All Models
	VAM-DBI-42-36-SL	1	42" x 36" Left Side Belt Conveyor Complete	All Models
	VAM-DBI-42-36-SR	1	42" x 36" Right Side Belt Conveyor Complete	All Models
	VAM-DBI-42-48-SL	1	42" x 48" Left Side Belt Conveyor Complete	All Models
	VAM-DBI-42-48-SR	1	42" x 48" Right Side Belt Conveyor Complete	All Models
	VAM-DBI-42-60-SL	1	42" x 60" Left Side Belt Conveyor Complete	All Models
	VAM-DBI-42-60-SR	1	42" x 60" Right Side Belt Conveyor Complete	All Models
1	M3-1-7-0044-1	1	42" x 24" Belt Conveyor Frame Weldment	All Models
	M3-1-7-0035-1	1	42" x 36" Belt Conveyor Frame Weldment	All Models
	M3-1-7-0041-1	1	42" x 48" Belt Conveyor Frame Weldment	All Models
	M3-1-7-0039-1	1	42" x 60" Belt Conveyor Frame Weldment	All Models
2	M3-1-7-0046	2	24" Side Belt Discharge Conveyor Floor	All Models
	M3-1-7-0036	2	36" Side Belt Discharge Conveyor Floor	All Models
	M3-1-7-0042	2	48" Side Belt Discharge Conveyor Floor	All Models
	M3-1-7-0040	2	60" Side Belt Discharge Conveyor Floor	All Models
3	VA-SCS-4224	1	24" Incline Skirt Seal Kit Prior to SN 19VM(0585202, 0815202, 1015204, 1215209)	585
	M3-1-7-0044-7	2	24" Incline Skirt Backer SN 19VM(0585202, 0815202, 1015204, 1215209) & Later	All Models
	VA-SCS-36	1	36" Incline Skirt Seal Kit Prior to SN 19VM(0585201, 0815201, 1015204, 1215209)	585
	M3-1-4-0035-4	2	36" Incline Skirt Backer SN 19VM(0585202, 0815202, 1015204, 1215209) & Later	All Models
	VA-SCS-48	1	48" Incline Skirt Seal Kit Prior to SN 19VM(0585201, 0815201, 1015204, 1215209)	585
	M3-1-4-0031-7	2	48" Incline Skirt Backer SN 19VM(0585202, 0815202, 1015204, 1215209) & Later	All Models
	VA-SCS-60	1	60" Incline Skirt Seal Kit Prior to SN 19VM(0585201, 0815201, 1015204, 1215209)	585
	M3-1-4-0051-7	2	60" Incline Skirt Backer SN 19VM(0585202, 0815202, 1015204, 1215209) & Later	All Models
4	M3-1-5-0049	1	Front Conveyor Motor Bracket	All Models
5	M3-1-7-0035-1-5	2	Pivot Spacer Prior to SN 19VM(0585201, 0815201, 1015204, 1215209)	585
	M3-1-4-0057-1-4	2	Pivot Spacer SN 19VM(0585202, 0815202, 1015204, 1215209) & Later	All Models

KEY	PART NUMBER	QTY	DESCRIPTION	MIXER MODEL
6	M3-1-8-0006	1	Coupler Cover Plate	All Models
7	See Page 146	1	Hydraulic Motor	All Models
8	VA-SCS-4224	1	24" Incline Skirt Seal Kit Prior to SN 19VM(0585202, 0815202, 1015204, 1215209)	585
	49-0351	2	24" Incline Side Skirting SN 19VM(0585202, 0815202, 1015204, 1215209) & Later	All Models
	VA-SCS-36	1	36" Incline Skirt Seal Kit Prior to SN 19VM(0585201, 0815201, 1015204, 1215209)	585
	49-0347	2	36" Incline Side Skirting SN 19VM(0585202, 0815202, 1015204, 1215209) & Later	All Models
	VA-SCS-48	1	48" Incline Skirt Seal Kit Prior to SN 19VM(0585201, 0815201, 1015204, 1215209)	585
	49-0345	2	48" Incline Side Skirting SN 19VM(0585202, 0815202, 1015204, 1215209) & Later	All Models
	VA-SCS-60	1	60" Incline Skirt Seal Kit Prior to SN 19VM(0585201, 0815201, 1015204, 1215209)	585
	49-0343	2	60" Incline Side Skirting SN 19VM(0585202, 0815202, 1015204, 1215209) & Later	All Models
9	37-0013-1	1	Unit Coupler, 1" Bore 1/4" Keyway	All Models
10	37-0013-2	1	Unit Coupler Chain, #50 16 Double With Connector	All Models
11	110-50B16-1.50-1	1	Chain Coupler Sprocket 1.5 Bore x 0.375" Keyway	All Models
	35-0006	1	3/8" x 3/8" x 1-1/4" Key	All Models
12	14-0070	4	1-1/2" - 4 Bolt Bearing	All Models
13	810-5013-Z	22	1/2" Spin Lock Nut (42" x 36" Belt Conveyor)	All Models
	810-5013-Z	24	1/2" Spin Lock Nut (42" x 24", 42" x 48", 42" x 60" Belt Conveyor)	All Models
14	850-5013-1.75Z	16	1/2"-13 x 1-3/4" Carriage Bolt, Grade 5	All Models
15	M3-1-8-0002	3	Front Conveyor Bearing Mount	All Models
16	49-0219	1	41.38" x 73" Belt, (42" x 24" Belt Conveyor).	All Models
	49-0193-MB	1	41.38" x 93" Belt, (42" x 36" Belt Conveyor)	All Models
	49-0199	1	41.38" x 117" Belt, (42" x 48" Belt Conveyor)	All Models
	49-0198-MB	1	41.38" x 141" Belt, (42" x 60" Conveyor)	All Models
	49-0193-3-AS	1	42" Conveyor Steel Belt Lacing Pin	All Models
17	M3-1-7-0052	2	Conveyor Idler Roll Scraper	All Models
	850-3118-.75Z	4	5/16"-18 x 3/4" Carriage Bolt	All Models
	814-3118-Z	4	5/16"-18 Indented Locknut	All Models
18	810-6311-Z	3	5/8" Spin Locknut	All Models
19	M3-1-7-0029	1	Chute Pivot Rod 1" Diameter x 45-1/4"	All Models
20	See Page 146	1	Hydraulic Cylinder	All Models
21	M3-1-4-0005	1	Extension Hydraulic Mount Weldment	All Models
22	M3-1-4-0006	1	Conveyor Link Arm Weldment	All Models
23	23-0266	1	1.5 Shaft x 49.375" Drive Pulley	All Models

KEY	PART NUMBER	QTY	DESCRIPTION	MIXER MODEL
24	23-0265	1	1.5 Shaft x 48.25" Cross Conveyor Idler Pulley	All Models
25	830-5013-4Z	3	Tap Bolt, 1/2"-13 x 4"	All Models
26	813-5013-Z	6	1/2"-13 Nut	All Models
27	49-0171	1	Door Frame Seal	All Models
28	M3-1-4-0024	2	Door Deflector (Belting)	All Models
29	M3-1-4-0025	2	Belt Chute Deflector	All Models
30	802T-3118-.75Z	7	5/16"-18 x 3/4" Truss Head Screw	All Models
31	815-3118-Z	7	5/16"-18 Nylon Insert Lock Nut, Left Side	All Models
32	850-3816-1Z	6	3/8"-16 x 1" Carriage Bolt, Grade 5	All Models
33	810-3816-Z	6	3/8" Spin Lock Nut	All Models
34	851-3816-1Z	8	3/8"-16 x 1" Grade 5 Machine Bolt	All Models
35	805-0038-Z	4	3/8" Flat Washer	All Models
36	815-3816-Z	8	3/8"-16 Nylon Insert Lock Nut	All Models
37	851-6311-1.5Z	3	5/8"-11 x 1-1/2" Grade 5 Machine Bolt	All Models
38	VA-SCS-4224	1	24" Incline Skirt Seal Kit Prior to SN 19VM(0585202, 0815202, 1015204, 1215209)	585
	M3-1-7-0044-5	1	24" Incline Side Skirt Bracket SN 19VM(0585202, 0815202, 1015204, 1215209) & Later	All Models
	VA-SCS-36	1	36" Incline Skirt Seal Kit Prior to SN 19VM(0585201, 0815201, 1015204, 1215209)	585
	M3-1-4-0035-5	1	36" Incline Side Skirt Bracket SN 19VM(0585202, 0815202, 1015204, 1215209) & Later	All Models
	VA-SCS-48	1	48" Incline Skirt Seal Kit Prior to SN 19VM(0585201, 0815201, 1015204, 1215209)	585
	M3-1-4-0031-5	1	48" Incline Side Skirt Bracket SN 19VM(0585202, 0815202, 1015204, 1215209) & Later	All Models
	VA-SCS-60	1	60" Incline Skirt Seal Kit Prior to SN 19VM(0585201, 0815201, 1015204, 1215209)	585
	M3-1-4-0051-5	1	60" Incline Side Skirt Bracket SN 19VM(0585202, 0815202, 1015204, 1215209) & Later	All Models
39	VA-SCS-4224	1	24" Incline Skirt Seal Kit Prior to SN 19VM(0585202, 0815202, 1015204, 1215209)	585
	M3-1-7-0044-6	1	24" Incline Side Skirt Bracket SN 19VM(0585202, 0815202, 1015204, 1215209) & Later	All Models
	VA-SCS-36	1	36" Incline Skirt Seal Kit Prior to SN 19VM(0585201, 0815201, 1015204, 1215209)	585
	M3-1-4-0035-6	1	36" Incline Side Skirt Bracket SN 19VM(0585202, 0815202, 1015204, 1215209) & Later	All Models
	VA-SCS-48	1	48" Incline Skirt Seal Kit Prior to SN 19VM(0585201, 0815201, 1015204, 1215209)	585
	M3-1-4-0031-6	1	48" Incline Side Skirt Bracket SN 19VM(0585202, 0815202, 1015204, 1215209) & Later	All Models
	VA-SCS-60	1	60" Incline Skirt Seal Kit Prior to SN 19VM(0585201, 0815201, 1015204, 1215209)	585
	M3-1-4-0051-6	1	60" Incline Side Skirt Bracket SN 19VM(0585202, 0815202, 1015204, 1215209) & Later	All Models

SIDE DISCHARGE CHAIN CONVEYOR

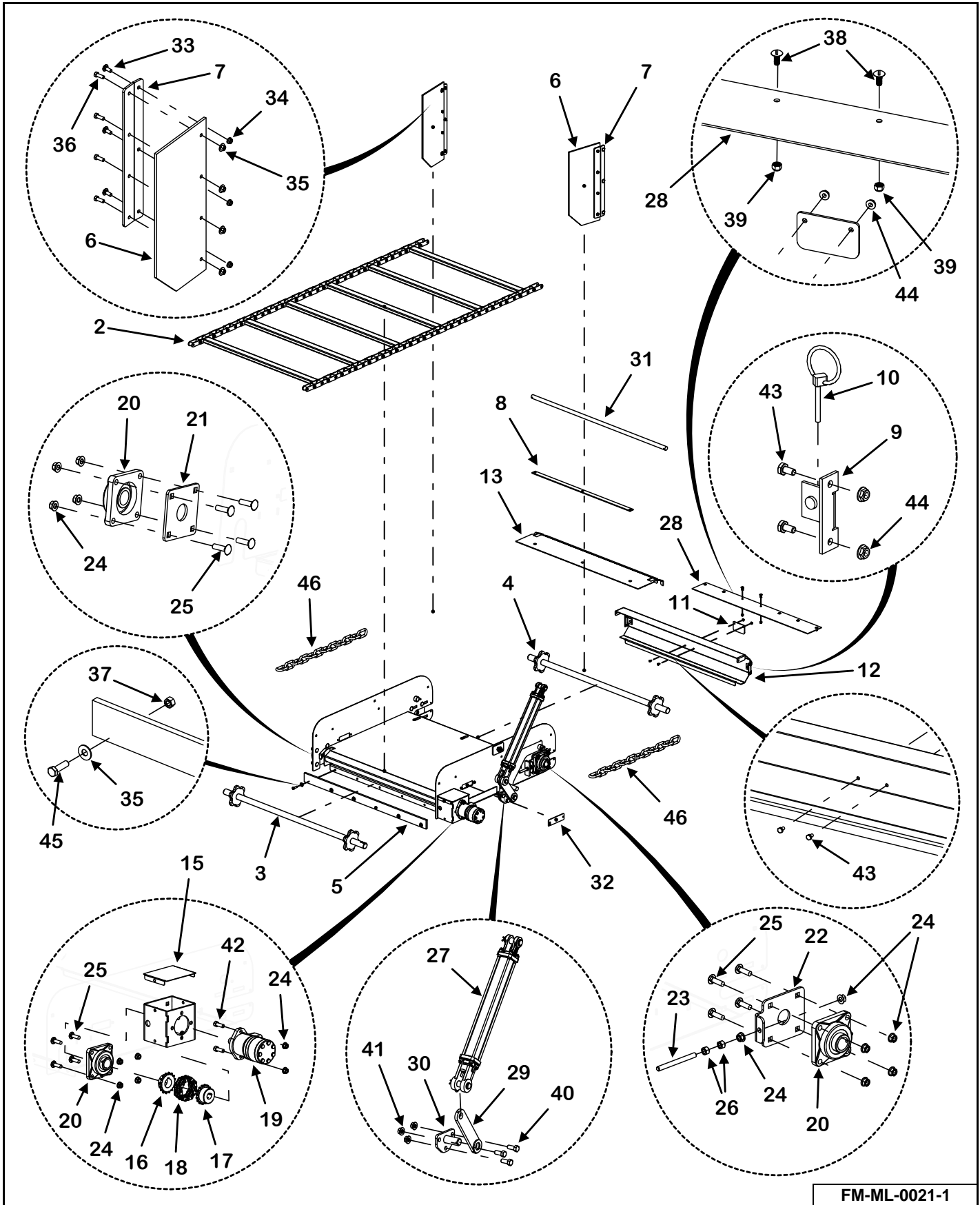

FM-ML-0021-1

KEY	PART NUMBER	QTY	DESCRIPTION	MIXER MODEL
0	VAM-DCI-42-36-SL	1	42" x 36" Left Chain Side Extension Complete	All Models
	VAM-DCI-42-36-SR	1	42" x 36" Right Chain Side Extension Complete	All Models
	VAM-DCI-42-48-SL	1	42" x 48" Left Chain Side Extension Complete	All Models
	VAM-DCI-42-48-SR	1	42" x 48" Right Chain Side Extension Complete	All Models
	VAM-DCI-42-60-SL	1	42" x 60" Left Chain Side Extension Complete	All Models
	VAM-DCI-42-60-SR	1	42" x 60" Right Chain Side Extension Complete	All Models
1	M3-1-12-0017-1	1	42" x 36" Chain Conveyor Weldment	All Models
	M3-1-12-0018-1	1	42" x 48" Chain Conveyor Weldment	All Models
	M3-1-12-0021-1	1	42" x 60" Chain Conveyor Weldment	All Models
	M3-1-12-0019-1	1	42" x 72" Chain Conveyor Weldment	All Models
2	11-0279	1	42" x 36" Side Discharge Conveyor 81X Chain Assembly	All Models
	11-0280	1	42" x 48" Side Discharge Conveyor 81X Chain Assembly	All Models
	11-0315	1	42" x 60" Side Discharge Conveyor 81X Chain Assembly	All Models
	11-0288	1	42" x 72" Side Discharge Conveyor 81X Chain Assembly	All Models
3	23-0258	1	Conveyor Drive Shaft Weldment	All Models
4	23-0259	1	Conveyor Idler Shaft Weldment	All Models
5	49-0180	1	Side Chain Conveyor Belt	All Models
6	M3-1-4-0024	2	Door Deflector (Belting)	All Models
7	M3-1-4-0025	2	Belt Chute Deflector	All Models
8	M3-1-12-0009	1	Extension Adjustment Bracket Weldment	All Models
9	M3-1-7-0034	2	Conveyor Extension Cover Latch Weldment	All Models
10	823-0003	2	Lynch Pin 3/16" x 1-1/4"	All Models
11	M3-1-7-0005-2	1	Conveyor Extension Cover Handle	All Models
12	M3-1-12-0003-AS	1	Extension Back Plate	All Models
13	M3-1-12-0002	1	Extension Sprocket Cover	All Models
14	M3-1-8-0034	1	Front Conveyor Motor Bracket	All Models
15	M3-1-8-0006	1	Coupler Cover Plate	All Models
16	110-50B16-1.50-1	1	Chain Coupler Sprocket	All Models
17	37-0013-1	1	Unit Coupler, 1" Bore 1/4" Keyway	All Models
18	37-0013-2	1	Unit Coupler Chain, #50 16 Double with Connector	All Models

SIDE DISCHARGE CHAIN CONVEYOR (CONT'D)

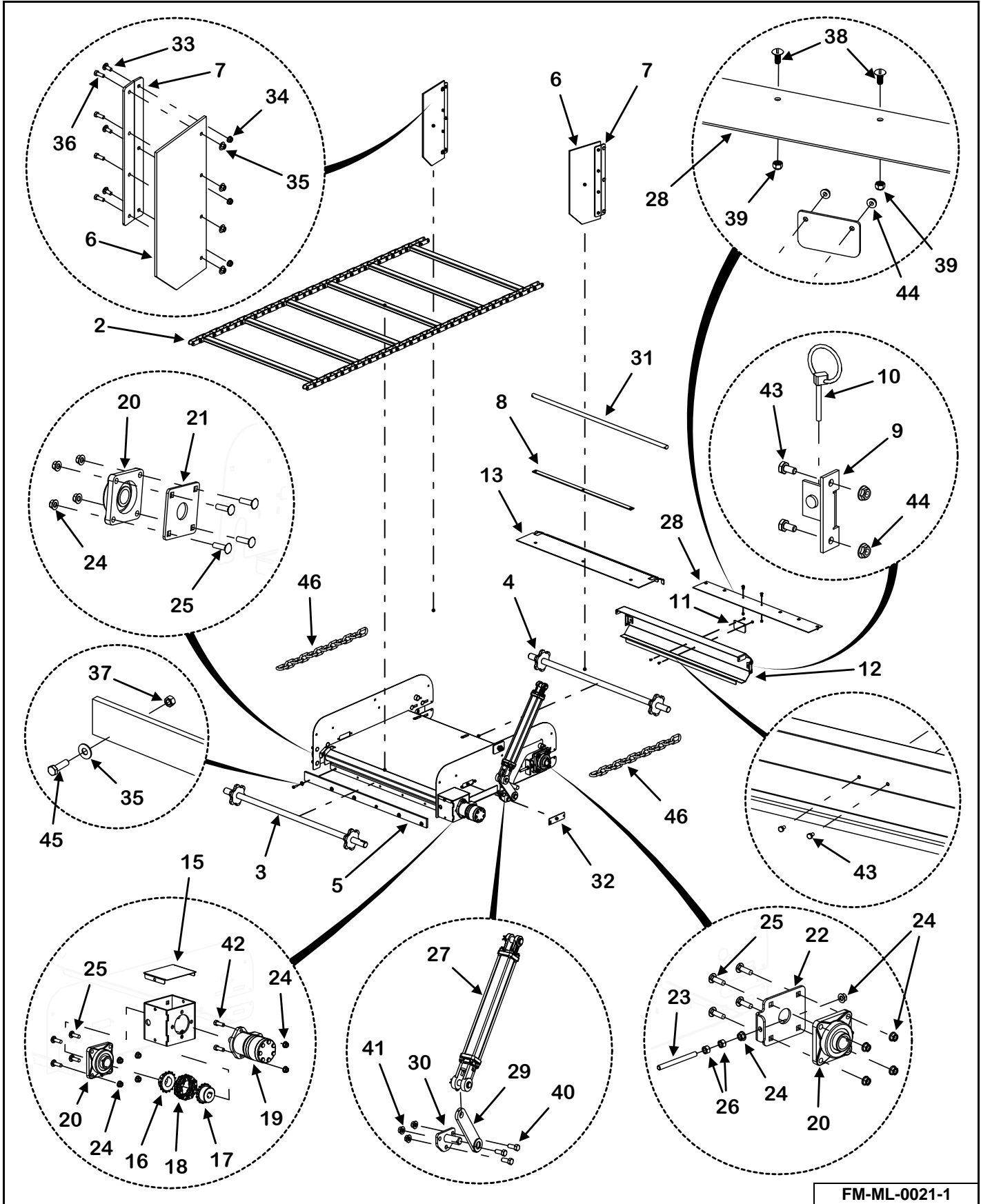

FM-ML-0021-1

KEY	PART NUMBER	QTY	DESCRIPTION	MIXER MODEL
19	See Page 146		Hydraulic Motor	All Models
20	14-0070	1	1-1/2" 4-Bolt Bearing	All Models
21	M3-1-4-0002	1	Extension Bearing Mount Plate	All Models
22	M3-1-8-0002	2	Front Conveyor Bearing Mount	All Models
23	830-5013-4Z	2	Tap Bolt, 1/2"-13 x 4"	All Models
24	810-5013-Z	22	1/2"-13 Spin Lock Nut	All Models
25	850-5013-1.75Z	16	1/2"-13 x 1-3/4" Carriage Bolt, Grade 5	All Models
26	813-5013-Z	8	1/2"-13 Nut	All Models
27	See Page 146		Hydraulic Cylinder	All Models
28	49-0171	1	Door Frame Seal	All Models
29	M3-1-4-0006	1	Conveyor Link Arm Weldment	All Models
30	M3-1-4-0005	1	Extension Hydraulic Mount Weldment	All Models
31	M3-1-12-0008	1	Chute Pivot Rod	All Models
32	M3-1-4-0015-2	2	Chute Cover	All Models
33	850-3816-1Z	6	3/8"-16 x 1" Carriage Bolt	All Models
34	810-3816-Z	6	3/8"-16 Spin Lock Nut	All Models
35	805-0038-Z	6	3/8" Flat Washer	All Models
36	851-3816-1Z	8	3/8"-16 x 1" Machine Bolt	All Models
37	815-3816-Z	14	3/8"-16 Nylon Insert Lock Nut	All Models
38	802T-3118-.75Z	7	5/16"-18 x 3/4" Truss Head Machine Screw	All Models
39	815-3118-Z	7	5/16"-18 Nylon Insert Lock Nut	All Models
40	851-6311-1.5Z	3	5/8"-11 x 1-1/2" Machine Bolt	All Models
41	810-6311-Z	3	5/8"-11 Spin Locknut	All Models
42	851-5013-1.5Z	2	1/2"-13 x 1-1/2" Bolt	All Models
43	851-2520-.5Z	4	1/4"-20 x 1/2" Machine Bolt	All Models
44	810-2520-Z	4	1/4"-20 Spin Lock Nut	All Models
45	851-3816-1.25Z	6	3/8"-16 x 1-1/4" Machine Bolt	All Models
46	M3-1-4-0001-2	2	Chain Stop 1/4" Chain	All Models

KEY	PART NUMBER	QTY	DESCRIPTION	MIXER MODEL
1	155-08R17-208-1	2	1/2" x 208" Hose Assembly	All Models
2	155-08R17-85-1	2	1/2" x 85" Hose Assembly (42" x 24", 42" x 36" Belt & Chain Conveyor)	All Models
	155-08R17-85-1	2	1/2" x 85" Hose Assembly (42" x 48" Belt Conveyor)	All Models
	155-08R17-97-1	2	1/2" x 97" Hose Assembly (42" x 48" Chain Conveyor)	All Models
	155-08R17-97-1	2	1/2" x 97" Hose Assembly (42" x 60" Belt Conveyor)	All Models
	155-08R17-109-1	2	1/2" x 109" Hose Assembly (42" x 60" Chain Conveyor)	All Models
	155-08R17-109-1	2	1/2" x 109" Hose Assembly (42" x 72" Belt Conveyor)	All Models
3	155-04R17-70-1	1	1/4" x 70" Hose Assembly	All Models
4	155-04R17-52-1	1	1/4" x 52" Hose Assembly	All Models
5	155-2-16-1.125-1	1	2" x 16" x 1-1/8" Hydraulic Cylinder	All Models
6	155-WR-12.1-1	1	12.1 Cubic Inch 2-Bolt Motor	All Models
	155-WR-SK-1	1	Motor Seal Kit	All Models
7	155-CV-8-1	1	Check Valve	All Models
8	155-6801-6-8	1	#6 JIC Male, #8 ORB Male Adjustable 90°	All Models
9	155-6400-8-8	2	#8 JIC Male, #8 ORB Male Straight Connector	All Models
10	155-6801-6-8-55	1	#6 x #8 90° Adj Elbow With .055" Orifice	All Models
11	155-6802-8-10	2	#8 JIC Male, #10 ORB Male Adjustable 45°	All Models
12	155-2603-08-08-06	2	#8 x #8 x #8 JIC Male Tube Tee	All Models
13	155-8010-15	2	#8 ORB Male Tip 1/2" Body Size	All Models

DOOR

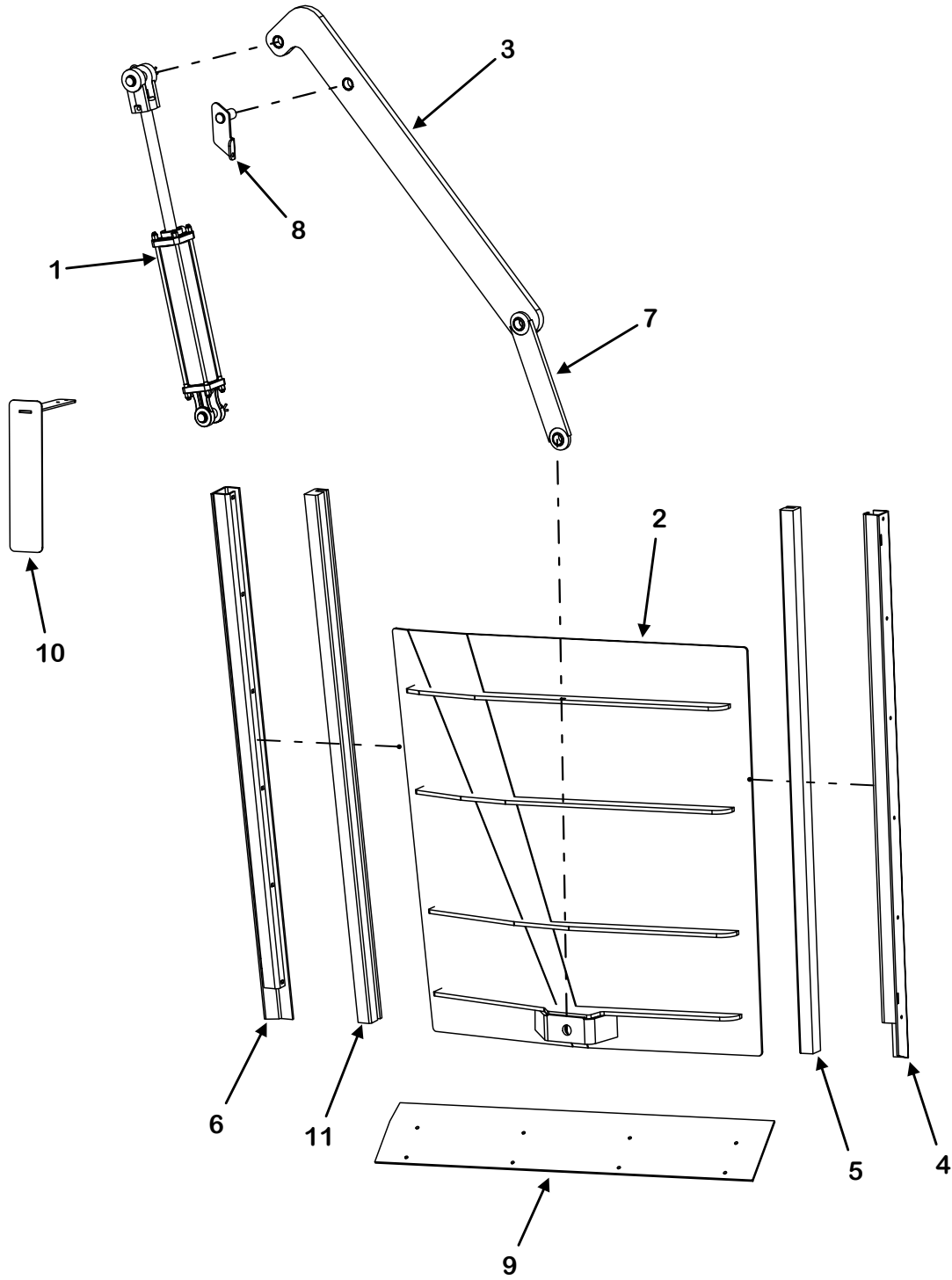

FM-ML-0024-1

KEY	PART NUMBER	QTY	DESCRIPTION	MIXER MODEL
1	155-2.5-12-1.125-1	1	2-1/2" x 12" x 1-1/8" Hydraulic Cylinder	All Models
2	M6-1-7-0004	1	Rear / Front Door Weldment	All Models
	M6-1-7-0007	1	Left Side Door Weldment	All Models
	M6-1-7-0009	1	Right Side Door Weldment	All Models
3	M6-1-7-0005	1	Door Arm	All Models
	M6-1-8-0006-2	2	Spring Bushing 1" ID x 1-1/4" OD x 3/4"	All Models
4	M6-1-8-0002	1	Right Door Frame Guide Assembly	All Models
5	M6-1-10-0007-R	1	Right Poly Door Slide (Facing Door)	All Models
	850-3118-2.5Z	6	Carriage Bolt, 5/16"-18 x 2-1/2"	All Models
	814-3118-Z	6	Indented Lock Nut, 5/16"-18	All Models
6	M6-1-8-0004	1	Left Door Frame Guide Assembly	All Models
7	M6-1-8-0008	1	Door Link Arm Assembly	All Models
	851-1008-3Z	2	Machine Bolt, 1"-8 x 3"	All Models
	815-1008-Z	2	Lock Nut, 1"-8 Nylon Insert	All Models
8	M6-1-8-0009	1	Front & Rear Door Link Pivot Pin Assembly	All Models
	M6-1-7-0010	1	Right Door Pivot Pin Assembly	All Models
	M6-1-7-0011	1	Left Door Pivot Pin Assembly	All Models
	851-3816-1.25Z	1	3/8"-16 x 1-1/4" Machine Bolt	All Models
	805-0038-Z	2	3/8" Flat Washer	All Models
	815-3816-Z	1	3/8"-16 Nylon Insert Lock Nut	All Models
9	M11-1-0019	1	Magnet Cover Plate (Side Door Only)	All Models
10	M2-1-7-0001-47	AR	Left/Right Side Discharge Door Indicator Weldment	All Models
	46-M-0006	AR	Door Open Indicator Decal	All Models
11	M6-1-10-0007-L	1	Left Poly Door Slide (Facing Door)	All Models
	850-3118-2.5Z	6	Carriage Bolt, 5/16"-18 x 2-1/2"	All Models
	814-3118-Z	6	Indented Lock Nut, 5/16"-18	All Models

**OPTIONAL REAR DOOR HYDRAULIC SCHEMATIC FOR
FRONT DOOR & SIDE DOOR MODELS**

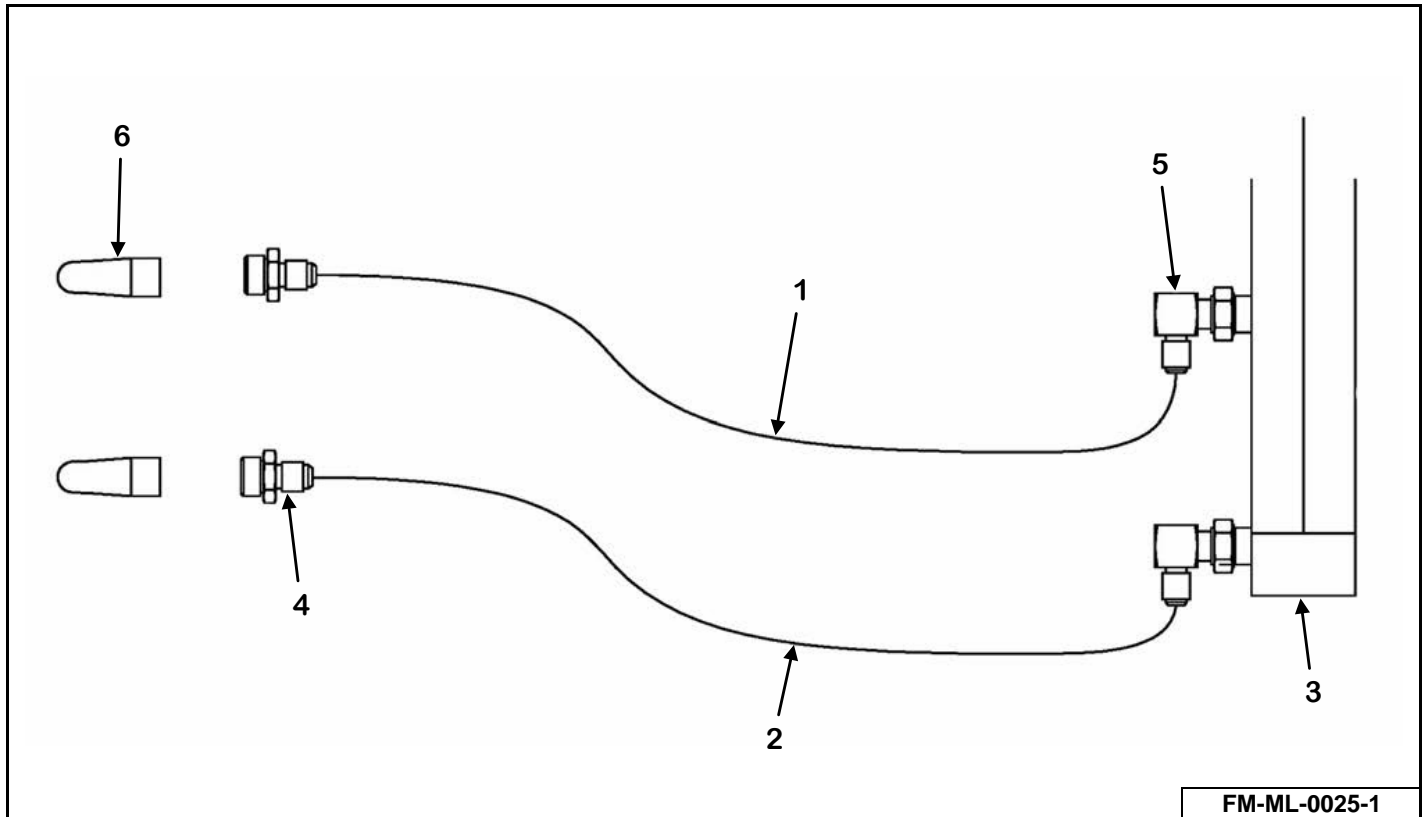

FM-ML-0025-1

KEY	PART NUMBER	QTY	DESCRIPTION	MIXER MODEL
1	155-04R17-373-1	1	1/4" x 373" Hose Assembly (Optional Rear Door For Side Door)	585/700
	155-04R17-387-1	1	1/4" x 387" Hose Assembly (Optional Rear Door For Front Door)	585/700
	155-04R17-367-1	1	1/4" x 367" Hose Assembly (Optional Rear Door For Side & Front Door)	F2-585/F2-700
2	155-04R17-354-1	1	1/4" x 354" Hose Assembly (Optional Rear Door For Side Door)	585/700
	155-04R17-373-1	1	1/4" x 373" Hose Assembly (Optional Rear Door For Front Door)	585/700
	155-04R17-379-1	1	1/4" x 379" Hose Assembly (Optional Rear Door For Side Door)	F2-585/F2-700
	155-04R17-382-1	1	1/4" x 382" Hose Assembly (Optional Rear Door For Front Door)	F2-585/F2-700
3	155-2-5-12-1.125-1	1	2-1/2" x 12" x 1-1/8" Hydraulic Cylinder	All Models
4	155-6400-6-8	2	#6 JIC Male, #8 ORB Male Straight Connector	All Models
5	155-6801-6-8	2	#6 JIC Male, #8 ORB Male Adjustable 90°	All Models
6	155-8010-15	2	#8 ORB Male Tip 1/2" Body Size	All Models

DOOR HYDRAULIC SCHEMATIC FRONT / LEFT / RIGHT / DUAL LEFT & RIGHT DOOR

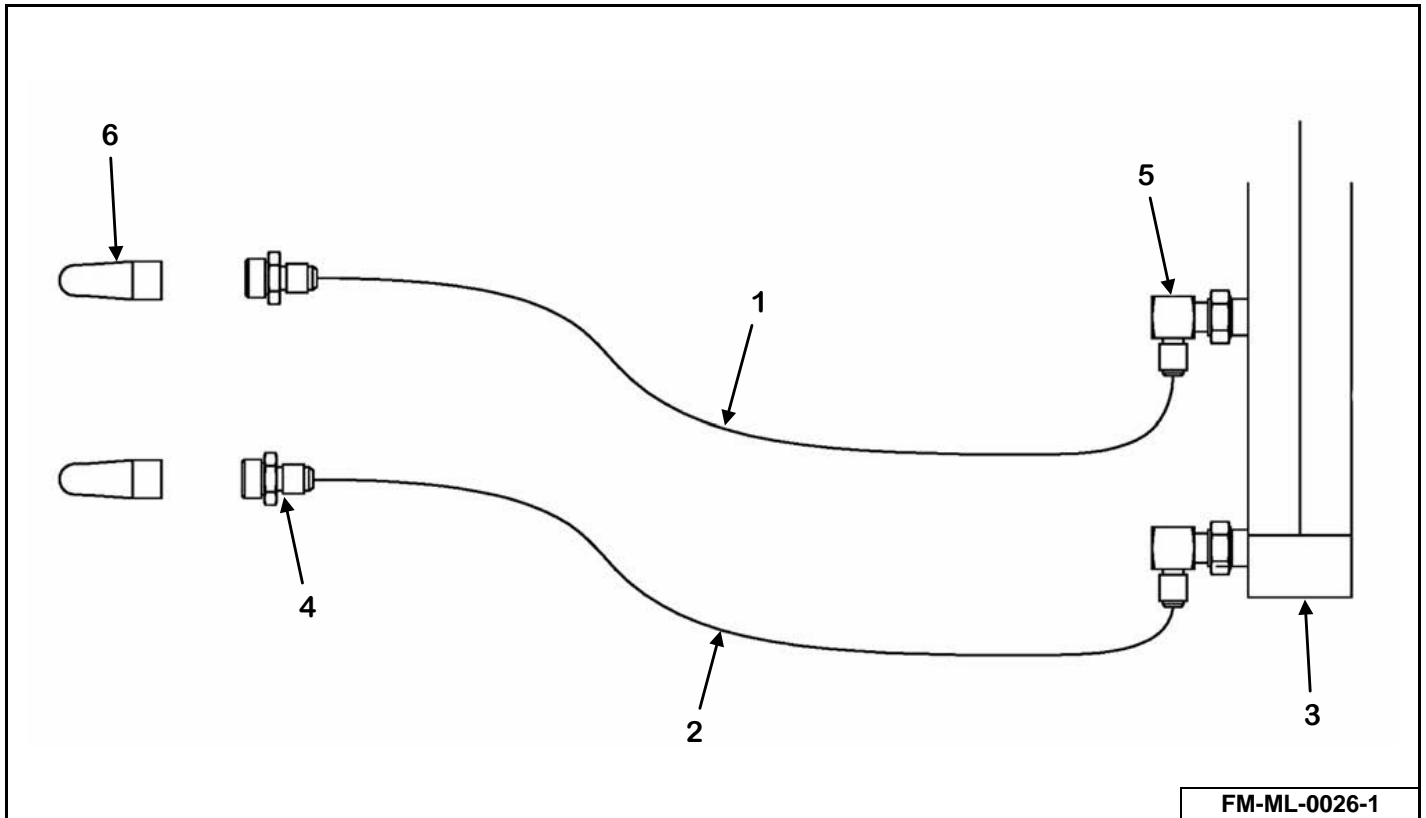

KEY	PART NUMBER	QTY	DESCRIPTION	MIXER MODEL
1	155-04R17-208-1	1	1/4" x 208" Hose Assembly (Left, Right & Front Doors)	585/700
	155-04R17-205-1	1	1/4" x 205" Hose Assembly (Left & Right Doors)	F2-585/F2-700
	155-04R17-212-2	1	1/4" x 212" Hose Assembly (Front Door)	F2-585/F2-700
2	155-04R17-193-1	1	1/4" x 193" Hose Assembly (Left, Right & Front Doors)	585/700
	155-04R17-190-1	1	1/4" x 190" Hose Assembly (Left & Right Doors)	F2-585/F2-700
	155-04R17-225-1	1	1/4" x 225" Hose Assembly (Front Door)	F2-585/F2-700
3	155-2-5-12-1.125-1	1	2-1/2" x 12" x 1-1/8" Hydraulic Cylinder	All Models
4	155-6400-6-8	2	#6 JIC Male, #8 ORB Male Straight Connector	All Models
5	155-6801-6-8	2	#6 JIC Male, #8 ORB Male Adjustable 90°	All Models
6	155-8010-15	2	#8 ORB Male Tip 1/2" Body Size	All Models

LADDER

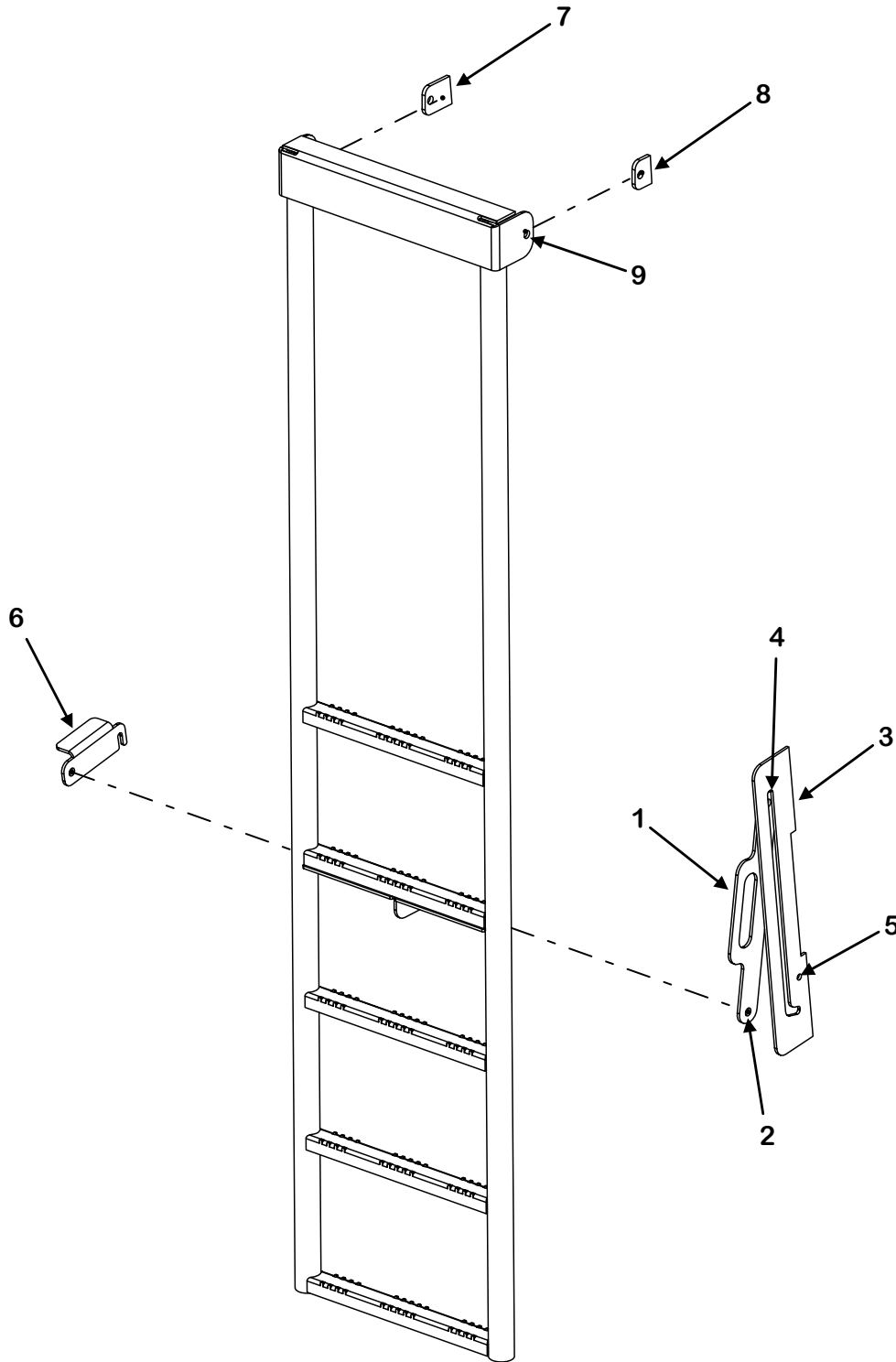

FM-ML-0027-1

KEY	PART NUMBER	QTY	DESCRIPTION	MIXER MODEL
0	M10-1-5-0001	1	Ladder Weldment	585/F2-585
	M10-1-7-0001	1	Ladder Weldment	700/F2-700
1	M10-1-4-0001-4	1	Ladder Handle	All Models
2	851-5013-1.75Z	1	1/2"-13 x 1-3/4" Bolt	All Models
	805-0050-Z	2	1/2" Flat Washer	All Models
	815-5013-Z	1	1/2"-13 Nylon Lock Nut	All Models
3	M2-1-4-0001-48	1	Ladder Guide (Welded On)	All Models
4	851-5013-1.5Z	1	1/2"-13 x 1-1/2" Bolt	All Models
	805-0050-Z	2	1/2" Flat Washer	All Models
	815-5013-Z	1	1/2"-13 Nylon Lock Nut	All Models
5	851-3816-1.5Z	1	3/8"-16 x 1-1/2" Bolt	All Models
	810-3816-Z	2	3/8" Spin Lock Nut	All Models
6	M10-1-4-0001-5	1	Ladder Latch	All Models
7	M2-1-7-0001-26	1	Left Ladder Mount, Front Discharge (Welded On)	All Models
	M2-1-7-0001-29	1	Left Ladder Mount, Side Discharge (Welded On)	All Models
8	M2-1-7-0001-25	1	Right Ladder Mount, Front Discharge (Welded On)	All Models
	M2-1-7-0001-28	1	Right Ladder Mount, Side Discharge (Welded On)	All Models
9	851-5013-1.5Z	2	1/2"-13 x 1-1/2" Bolt	All Models
	805-0050-Z	2	1/2" Flat Washer	All Models
	815-5013-Z	2	1/2"-13 Nylon Lock Nut	All Models

VIEWING PLATFORM

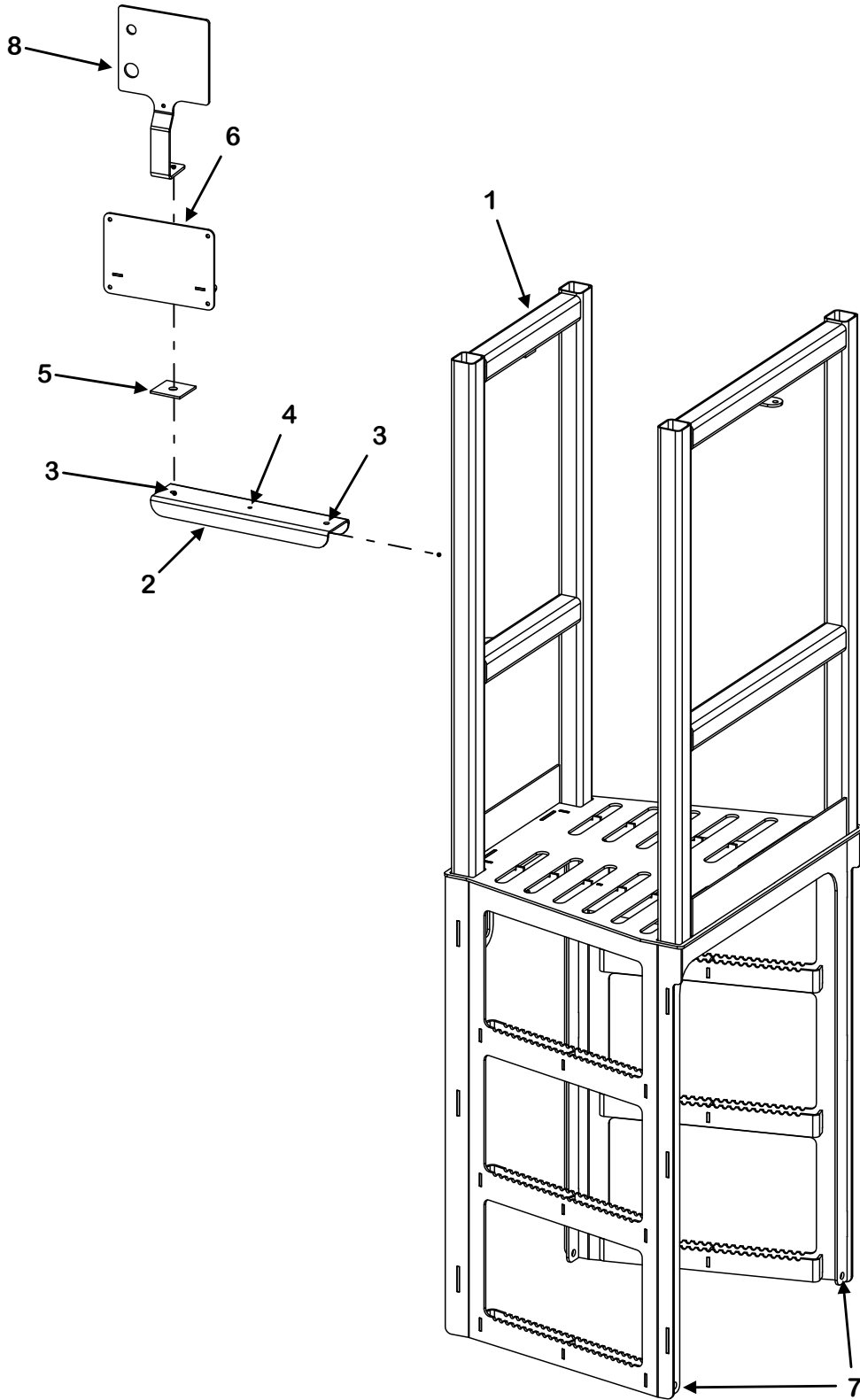

FM-M-0014-1

KEY	PART NUMBER	QTY	DESCRIPTION	MIXER MODEL
1	M10-1-5-0005	1	Viewing Platform Weldment	585
	M10-1-5-0012	1	Viewing Platform Weldment (Single Axle Front & Side Discharge) (Tandem Axle Side Discharge)	F2-585
	M10-1-5-0011	1	Viewing Platform Weldment (Tandem Axle Front Discharge)	F2-585
	M10-1-7-0003	1	Viewing Platform Weldment	700
	M10-1-7-0008	1	Viewing Platform Weldment (Single Axle Front & Side Discharge) (Tandem Axle Side Discharge)	F2-700
	M10-1-5-0007	1	Viewing Platform Weldment (Tandem Axle Front Discharge)	F2-700
2	M9-1-8-0003	1	Scale Arm	All Models
3	851-3816-1Z	2	3/8"-16 x 1" Machine Bolt	All Models
	815-3816-Z	2	3/8"-16 Nylon Insert Lock Nut	All Models
4	32-0033	1	1/2" Loom Clamp	All Models
	851-2520-.75Z	1	1/4"-20 x 3/4" Machine Bolt	All Models
	815-2520-Z	1	1/4"-20 Nylon Insert Locknut	All Models
5	M9-1-8-0004	2	Scale Arm Rubber Washer	All Models
6	M9-1-8-0002	1	Scale Indicator Mount	All Models
7	810-5013-Z	4	1/2" Spin Lock Nut	All Models
	851-5013-1.25Z	4	1/2"-13 x 1-1/4" Machine Bolt	All Models
8	MN11-1-0002-3	1	Indicator Light Bracket (Power Shift Models Only)	F2-585/F2-700

AUGER

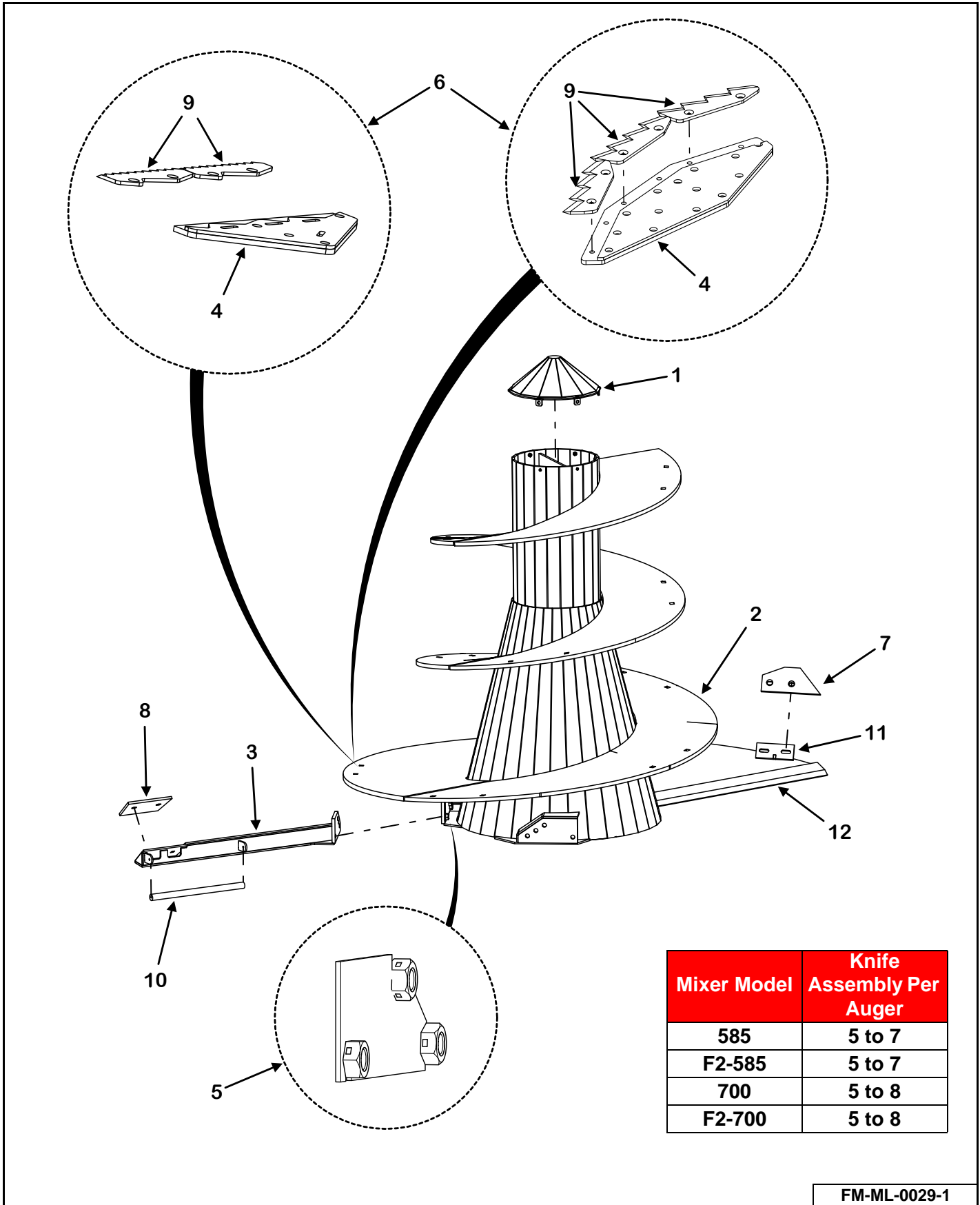

Mixer Model	Knife Assembly Per Auger
585	5 to 7
F2-585	5 to 7
700	5 to 8
F2-700	5 to 8

FM-ML-0029-1

KEY	PART NUMBER	QTY	DESCRIPTION	MIXER MODEL
0	M5-1-5-0004	2	Auger Assembly, Complete With Knives, Backer & Hardware	585
	M5-1-5-0007	2	Auger Assembly, Complete With Knives, Backer & Hardware	F2-585
	M5-1-5-0006	2	Stainless Lined Auger Assembly, Complete With Knives, Backer & Hardware	F2-585
	M5-1-7-0006	2	Auger Assembly, Complete With Knives, Backer & Hardware	700
	M5-1-7-0010	2	Auger Assembly, Complete With Knives, Backer & Hardware	F2-700
	M5-1-7-0011	2	Stainless Lined Auger Assembly, Complete With Knives, Backer & Hardware	F2-700
1	M5-1-8-0002	2	Auger Top Cap Weldment	All Models
	851-3118-1.25SS	6 per	5/16"-18 x 1-1/4" Stainless Steel Bolts	All Models
	805-0031-Z	6 per	5/16" Flat Washer	All Models
	822-0031-Z	6 per	5/16" Split Lock Washer	All Models
2	M5-1-5-0004-1	2	Auger Weldment	585
	M5-1-5-0007-1	2	Auger Weldment	F2-585
	M5-1-5-0006-1	2	Stainless Lined Auger Weldment	F2-585
	M5-1-7-0006-1	2	Auger Weldment	700
	M5-1-7-0010-1	2	Auger Weldment	F2-700
	M5-1-7-0011-1	2	Stainless Lined Auger Weldment	F2-700
3	M5-1-7-0005	2	Kicker Weldment	All Models
	See Page 211	2	Kicker Weldment With Magnet Kit (Optional)	All Models
	881-6311-1.75Z	4	5/8"-11 x 1-3/4" Bolt	All Models

AUGER (CONT'D)

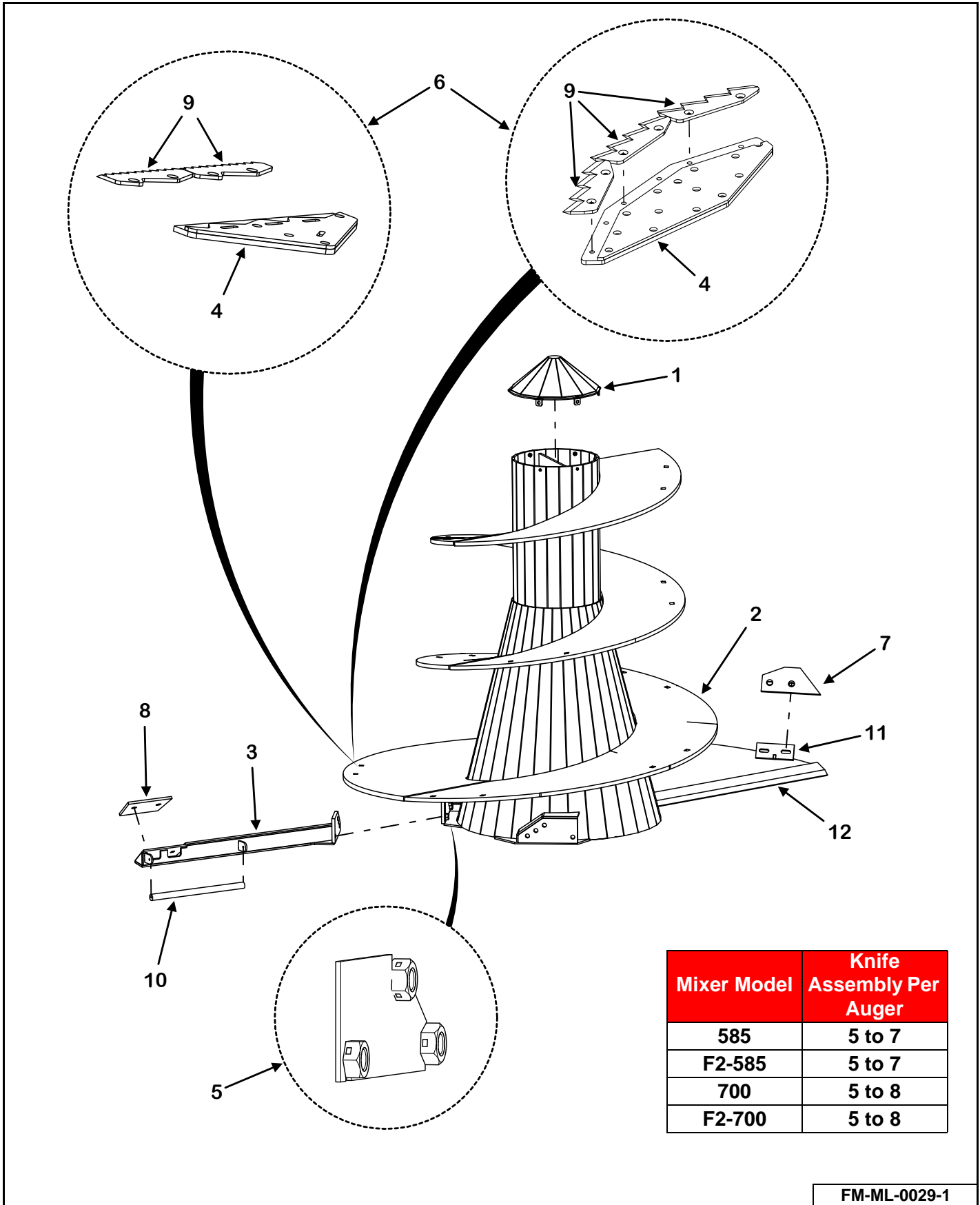

Mixer Model	Knife Assembly Per Auger
585	5 to 7
F2-585	5 to 7
700	5 to 8
F2-700	5 to 8

FM-ML-0029-1

KEY	PART NUMBER	QTY	DESCRIPTION	MIXER MODEL
4	M11-1-0040	AR	2-Knife Backer Weldment For Knives	All Models
	M11-1-0041	AR	2-Knife HD Backer Weldment For Knives	All Models
	M11-1-0048	AR	3-Knife Backer Weldment For Knives	All Models
	880-6311-2Z	1 per	5/8"-11 x 2" Carriage Bolt Zinc	All Models
	880-6311-2.5Z	1 per	5/8"-11 x 2" Carriage Bolt Zinc	All Models
	886-6311-Z	2 per	5/8"-11 Center Lock Nut	All Models
5	M5-1-8-0007	2	Auger Kicker Nut Holder Weldment	All Models
6	M11-1-0059-K	AR	Mixer 2-Knife Assembly (Includes Knives, Backers & Hardware)	All Models
	M11-1-0060-K	AR	Mixer 2-Knife With Doubler Assembly (Includes Knives, Backers & Hardware)	All Models
	M11-1-0054-K	AR	Mixer 3-Knife Assembly (Includes Knives, Backers & Hardware)	All Models
7	M5-1-8-0005-K	2	Auger Scraper With Hardware	All Models
	852-5013-1.75Z	2 per	1/2"-13 x 1-3/4" Flat Head Socket Cap Screw	All Models
	815-5013-Z	2 per	1/2"-13 Nylon Lock Nut	All Models
	828-0050-Z	2 per	1/2" SAE Washer	All Models
8	M5-1-8-0006-K	2	Kicker Wear Plate With Hardware	All Models
	852-5013-1.75Z	2 per	1/2"-13 x 1-3/4" Flat Head Socket Cap Screw	All Models
	815-5013-Z	2 per	1/2"-13 Nylon Lock Nut	All Models
	828-0050-Z	2 per	1/2" SAE Washer	All Models
9	M11-1-0050-K	AR	One Blade With Hardware	All Models
	803-3816-1Z	2 per	3/8"-16 x 1" Flat Head Socket Cap Screw	All Models
	814-3816-Z	2 per	3/8"-16 Center Lock Nut	All Models
10	See Page 211	AR	Kicker Magnet (Optional)	All Models
11	M5-1-8-0001-1-13	2	Scraper Mount (Welded On)	All Models
	M5-1-8-0001-1-14	2	Scraper Mount Gusset (Welded On)	All Models
12	M5-1-7-0001-1-3	2	Auger Lead Edge (Welded On)	All Models

585 & 700 STOP & SHIFT DRIVELINE

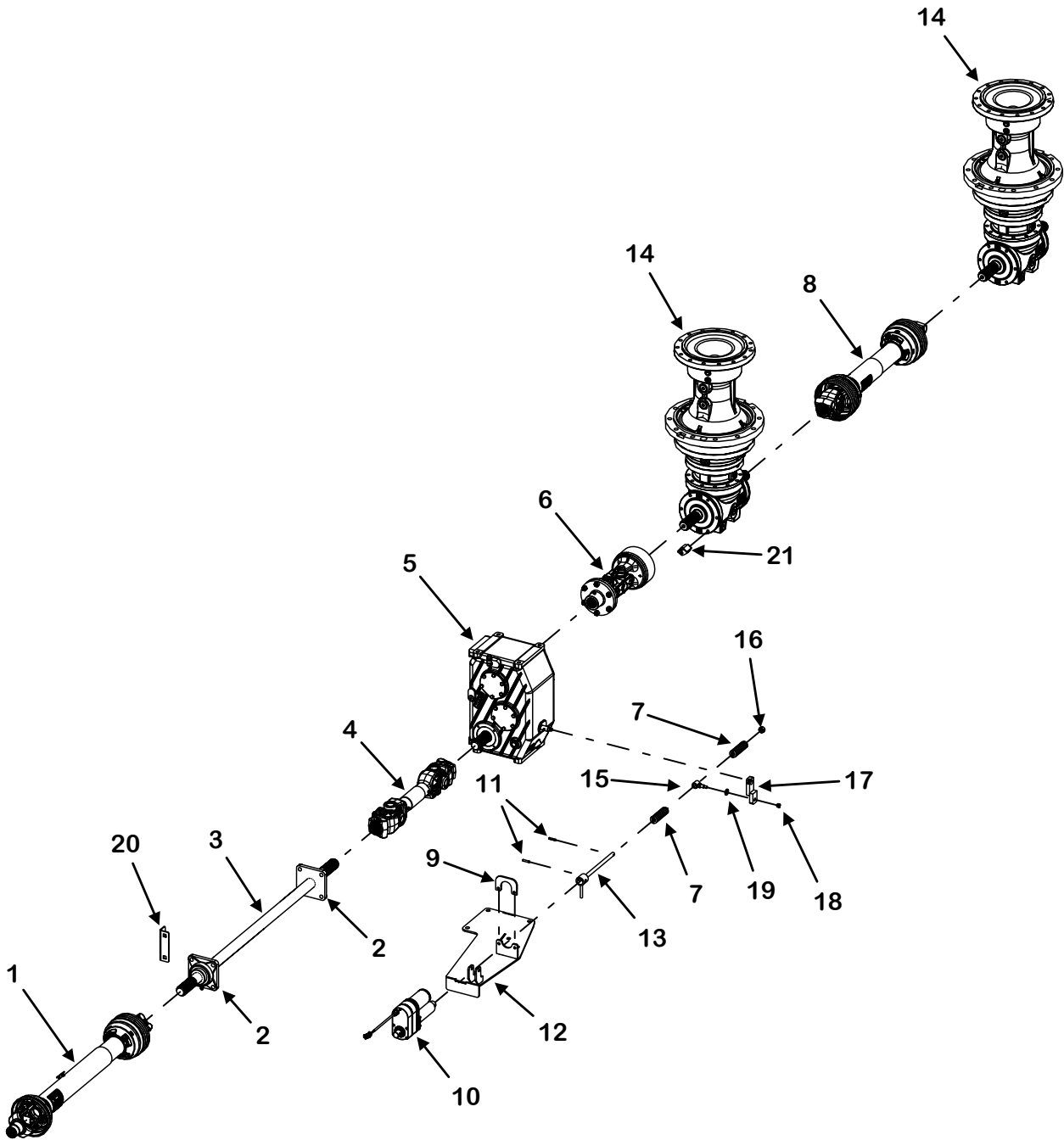

FM-M-0015-1

KEY	PART NUMBER	QTY	DESCRIPTION	MIXER MODEL
1	See Page 188	1	1-3/8"-21 Spline PTO Complete	585/700
	See Page 190	1	1-3/4"-20 Spline PTO Complete (Optional)	585/700
	See Page 192	1	1-3/8"-21 Spline PTO Complete (Optional)	585/700
	See Page 194	1	1-3/4"-20 Spline PTO Complete (Optional)	585/700
2	914-3819	2	1-3/4" 4-Bolt Bearing	585/700
3	123-1.75-0018	1	PTO Extension Drive Shaft, Front Discharge	585/700
	123-1.75-0017	1	PTO Extension Drive Shaft, Side Discharge	585/700
4	See Page 200	1	1-3/4"-20 Spline PTO Complete	585/700
5	See Page 168	1	2-Speed Shifting Gearbox 1.51:1/2.73:1 1.75-20 Spline	585/700
6	See Page 201	1	Double Universal Joint W/Cutout Clutch	585/700
7	29-0036	2	2-Speed Die Spring	585/700
8	See Page 204	1	Planetary to Planetary Drive Shaft	585/700
9	M11-2-0001-4	1	2-Speed Top Cylinder Mount	585/700
10	56-0123	1	12V Linear Actuator With Plug	585/700
11	38-0003	2	1/4" x 1-1/4" Roll Pin	585/700
12	M11-5-0006	1	2-Speed Shift Mount Weldment	585/700
13	M11-2-0003	1	2-Speed Shift Rod Weldment	585/700
14	See Page 178	2	1800 Series Planetary Gearbox	585/700
	851-6311-2.5Z	24	5/8"-11 x 2-1/2" Machine Bolt	585/700
	814-6311-Z	24	5/8"-11 Indented Lock Nut	585/700
15	M11-13-0006	1	Shift Pivot Tube Weldment	585/700
16	814-5612-Z	1	9/16"-12 Indented Lock Nut	585/700
17	M11-13-0013	1	Shifter Arm Weldment	585/700
18	814-3816-Z	1	3/8"-16 Indented Lock Nut	585/700
19	M11-13-0004-3	1	Spacer	585/700
20	M9-1-7-0001	1	Shaft Rotation Sensor Bracket	585/700
21	M9-1-8-0011	1	Planetary Rotation Counter Bracket	585/700

F2 DIRECT DRIVELINE

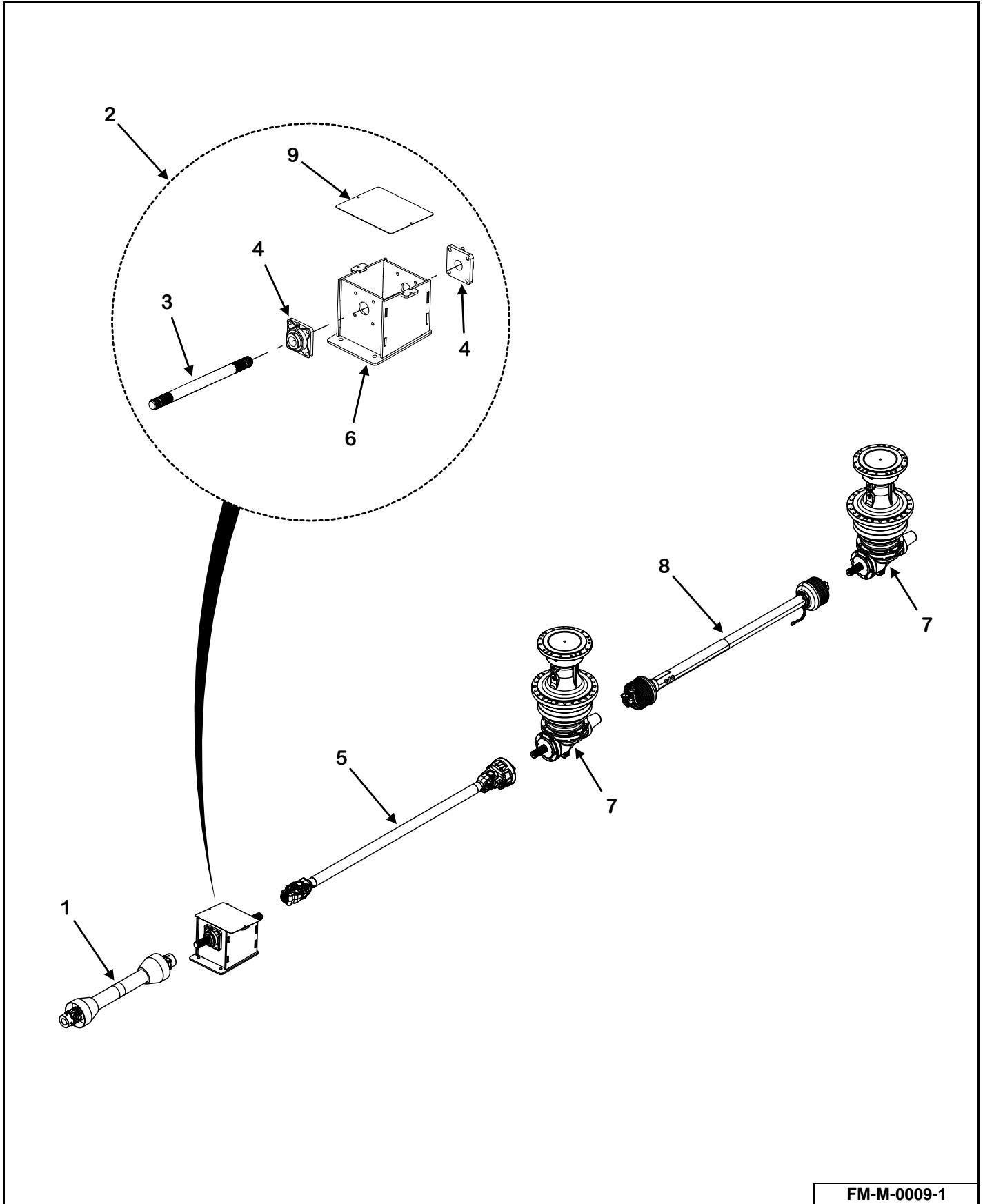

FM-M-0009-1

KEY	PART NUMBER	QTY	DESCRIPTION	MIXER MODEL
1	See Page 188	1	1-3/8"-21 Spline PTO Complete	F2-585/F2-700
	See Page 190	1	1-3/4"-20 Spline PTO Complete (Optional)	F2-585/F2-700
	See Page 192	1	1-3/8"-21 Spline PTO Complete (Optional)	F2-585/F2-700
	See Page 194	1	1-3/4"-20 Spline PTO Complete (Optional)	F2-585/F2-700
2	M1-7-0022	1	Direct Drive Assembly	F2-585/F2-700
3	123-1.75-0027	1	1-3/4" Diameter x 23" Direct Drive Input Shaft	F2-585/F2-700
4	914-3819	2	1-3/4" 4-Bolt Bearing	F2-585/F2-700
5	See Page 196	1	1-3/4"-20 Spline PTO (Front Discharge)	F2-585/F2-700
	See Page 198	1	1-3/4"-20 Spline PTO (Side Discharge)	F2-585/F2-700
6	M1-7-0022-1	1	Direct Drive Weldment	F2-585/F2-700
7	See Page 180	2	2100 Series Planetary Gearbox	F2-585/F2-700
8	See Page 204	1	1-3/4"-20 Spline PTO	F2-585/F2-700
9	M1-7-0022-2	1	Cover Plate	F2-585/F2-700

F2 STOP & SHIFT DRIVELINE

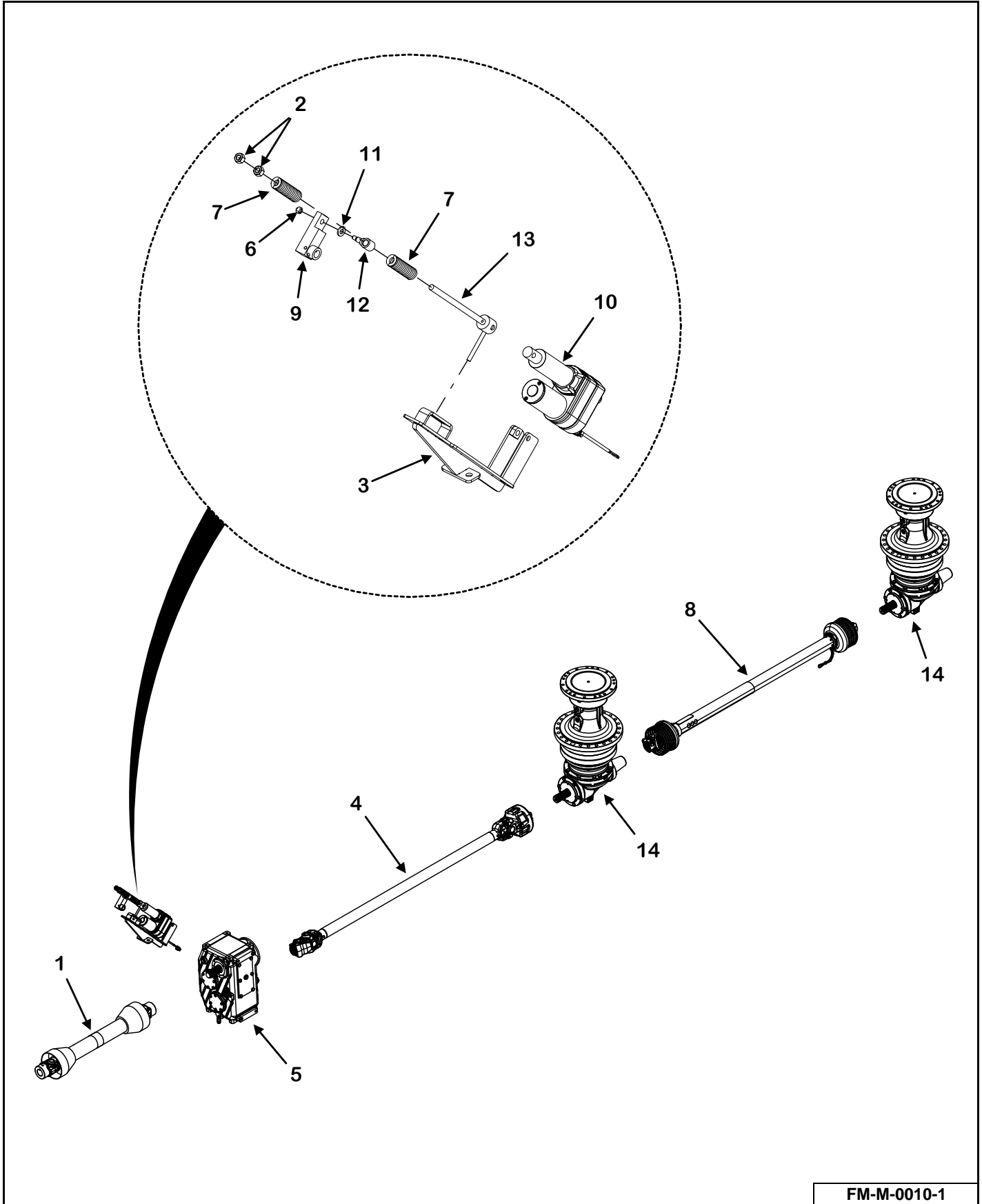

FM-M-0010-1

KEY	PART NUMBER	QTY	DESCRIPTION	MIXER MODEL
1	See Page 188	1	1-3/8"-21 Spline PTO Complete	F2-585/F2-700
	See Page 190	1	1-3/4"-20 Spline PTO Complete (Optional)	F2-585/F2-700
	See Page 192	1	1-3/8"-21 Spline CV PTO Complete (Optional)	F2-585/F2-700
	See Page 194	1	1-3/4"-20 Spline CV PTO Complete (Optional)	F2-585/F2-700
2	814-5612-Z	2	9/16"-12 Indented Lock Nut	F2-585/F2-700
3	M11-5-0007	1	Shift Mount Weldment	F2-585/F2-700
4	See Page 196	1	1-3/4"-20 Spline PTO Complete (Front Discharge)	F2-585/F2-700
	See Page 198	1	1-3/4"-20 Spline PTO Complete (Side Discharge)	F2-585/F2-700
5	See Page 172	1	2-Speed Shifting Gearbox 1.00:1/1.50:1 1.75-20 Spline	F2-585/F2-700
6	814-3816-Z	1	3/8"-16 Indented Lock Nut	F2-585/F2-700
7	29-0036	2	2-Speed Die Spring	F2-585/F2-700
8	See Page 204	1	Planetary to Planetary Drive Shaft	F2-585/F2-700
9	M11-5-0008	1	Shifter Arm Weldment	F2-585/F2-700
10	56-0123	1	12V Linear Actuator With Plug	F2-585/F2-700
11	M11-13-0004-3	1	Spacer	F2-585/F2-700
12	M11-13-0006	1	Shift Pivot Tube Weldment	F2-585/F2-700
13	M11-2-0003	1	2-Speed Shift Rod Weldment	F2-585/F2-700
14	See Page 180	2	2100 Series Planetary Gearbox	F2-585/F2-700
	851-6311-2.5Z	24	5/8"-11 x 2-1/2" Machine Bolt	F2-585/F2-700
	814-6311-Z	24	5/8"-11 Indented Lock Nut	F2-585/F2-700

F2 POWER SHIFT DRIVELINE

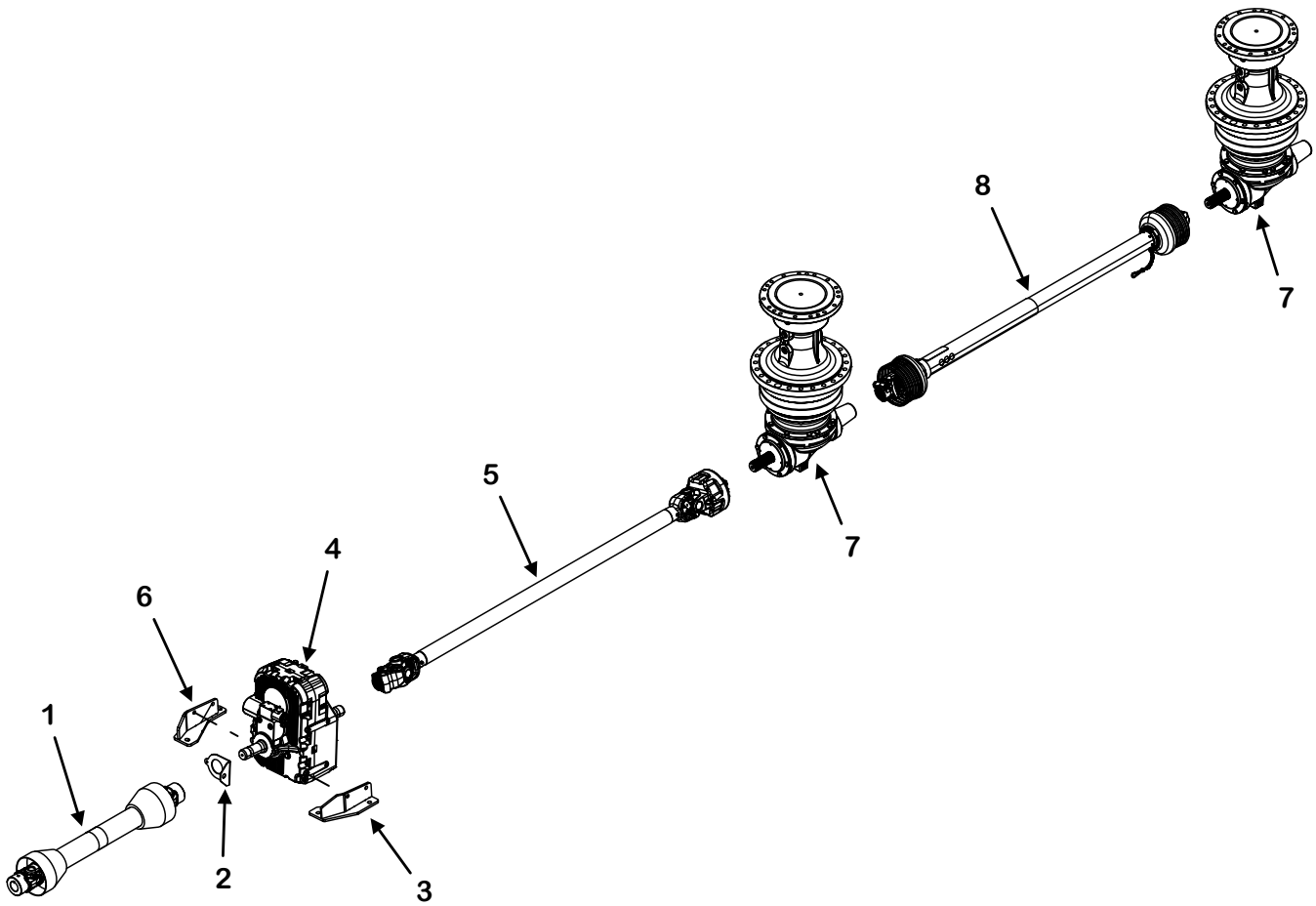

FM-M-0011-1

KEY	PART NUMBER	QTY	DESCRIPTION	MIXER MODEL
1	See Page 188	1	1-3/8"-21 Spline PTO Complete	F2-585/F2-700
	See Page 190	1	1-3/4"-20 Spline PTO Complete (Optional)	F2-585/F2-700
	See Page 192	1	1-3/8"-21 Spline CV PTO Complete (Optional)	F2-585/F2-700
	See Page 194	1	1-3/4"-20 Spline CV PTO Complete (Optional)	F2-585/F2-700
2	M2-1-7-0023	1	Speed Switch Mount Plate	F2-585/F2-700
3	M1-7-0020	1	Left Power Shift Transmission Mount	F2-585/F2-700
4	See Pages 176	1	Zuidberg 2-Speed Automatic Transmission	F2-585/F2-700
5	See Page 196	1	1-3/4"-20 Spline PTO (Front Discharge)	F2-585/F2-700
	See Page 198	1	1-3/4"-20 Spline PTO (Side Discharge)	F2-585/F2-700
6	M1-7-0021	1	Right Power Shift Transmission Mount	F2-585/F2-700
7	See Page 180	2	2100 Series Planetary Gearbox	F2-585/F2-700
8	See Page 204	1	1-3/4"-20 Spline PTO	F2-585/F2-700

585 & 700 STOP & SHIFT GEARBOX

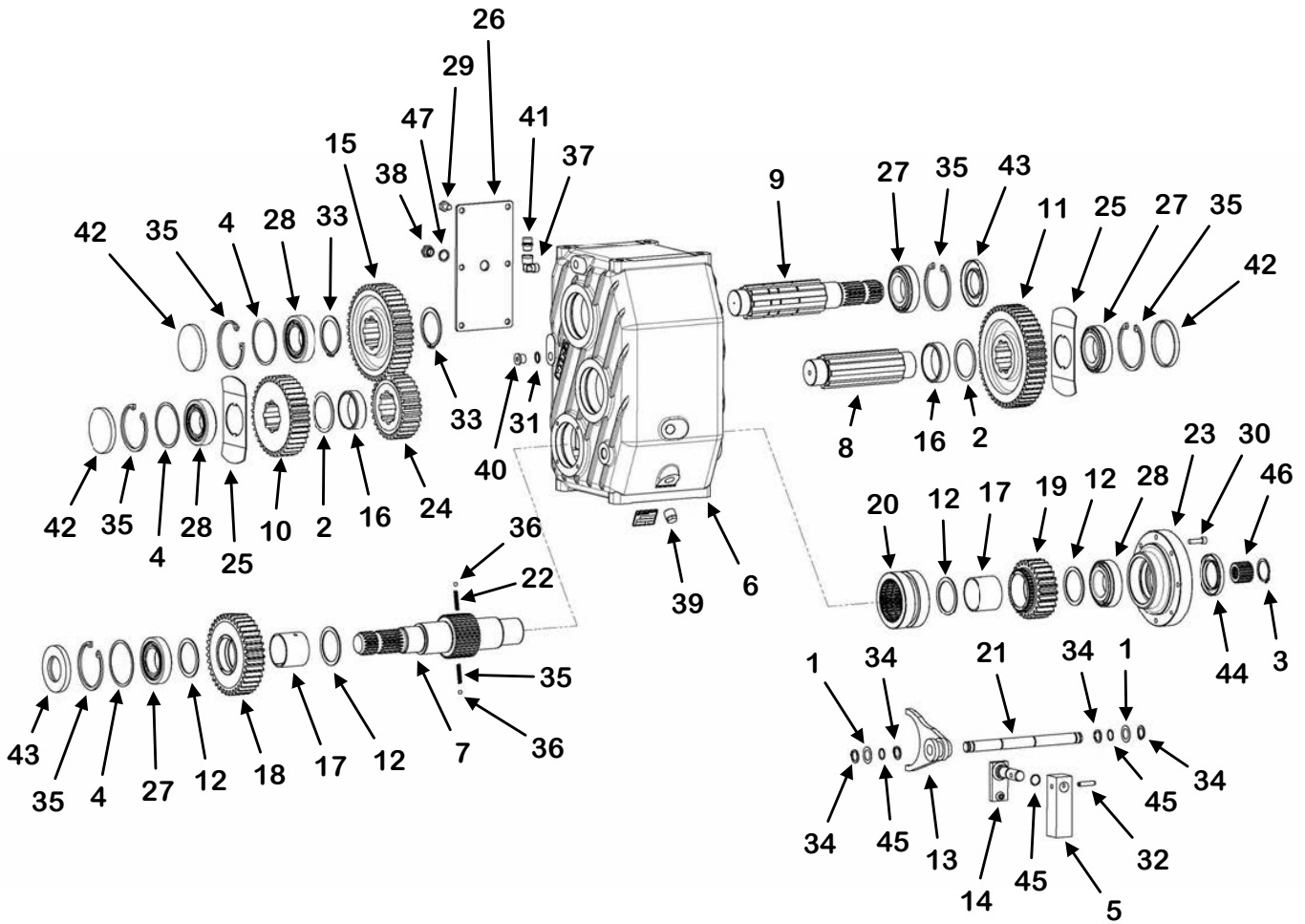

119-2SP-1.5-2.7-1

KEY	PART NUMBER	QTY	DESCRIPTION
0	119-2SP-1.5-2.7-1K	1	2-Speed Shifting Gearbox 1.51:1/2.73:1 1.75-20 Spline Prior to SN 23VM(0585209, 0700208)
	119-2SP-1.5-2.7-2K	1	2-Speed Shifting Gearbox 1.51:1/2.73:1 1.75-20 Spline SN 23VM(0585209, 0700208) & Later
1	119-2SP-C-1	2	Shim Kit
2	119-2SP-C-122	2	Shim
3	119-2SP-C-134	1	Snap Ring
4	119-2SP-C-85	3	Shim Kit
5	119-2SP-C-30	1	Outer Lever
6	119-2SP-C-123	1	Housing
7	119-2SP-C-87	1	Shaft Prior to SN 23VM(0585209, 0700208)
	119-2SP-C-140	1	Shaft SN 23VM(0585209, 0700208) & Later
8	119-2SP-C-88	1	Middle Shaft
9	119-2SP-C-89	1	Shaft
10	119-2SP-C-124	1	Gear Prior to SN 23VM(0585209, 0700208)
	119-2SP-C-136	1	Gear SN 23VM(0585209, 0700208) & Later
11	119-2SP-C-125	1	Gear Prior to SN 23VM(0585209, 0700208)
	119-2SP-C-137	1	Gear SN 23VM(0585209, 0700208) & Later
12	119-2SP-C-91	4	Thrust Washer
13	119-2SP-C-92	1	Fork
14	119-2SP-C-93	1	Inner Lever
15	119-2SP-C-95	1	Crown Wheel Prior to SN 23VM(0585209, 0700208)
	119-2SP-C-141	1	Crown Wheel SN 23VM(0585209, 0700208) & Later
16	119-2SP-C-126	2	Spacer
17	119-2SP-C-97	2	Bushing
18	119-2SP-C-98	1	Gear Prior to SN 23VM(0585209, 0700208)
	119-2SP-C-138	1	Gear SN 23VM(0585209, 0700208) & Later
19	119-2SP-C-127	1	Gear Prior to SN 23VM(0585209, 0700208)
	119-2SP-C-139	1	Gear SN 23VM(0585209, 0700208) & Later
20	119-2SP-C-99	1	Slide Gear Prior to SN 23VM(0585209, 0700208)
	119-2SP-C-142	1	Slide Gear SN 23VM(0585209, 0700208) & Later
21	119-2SP-C-100	1	Gear Selector Rod
22	119-2SP-C-101	2	Spring
23	119-2SP-C-128	1	Flange Saw
24	119-2SP-C-129	1	Gear Prior to SN 23VM(0585209, 0700208)
	119-2SP-C-143	1	Gear SN 23VM(0585209, 0700208) & Later
25	119-2SP-C-105	2	Lubricating Sheet
26	119-2SP-C-106	1	Cover

585 & 700 STOP & SHIFT GEARBOX (CONT'D)

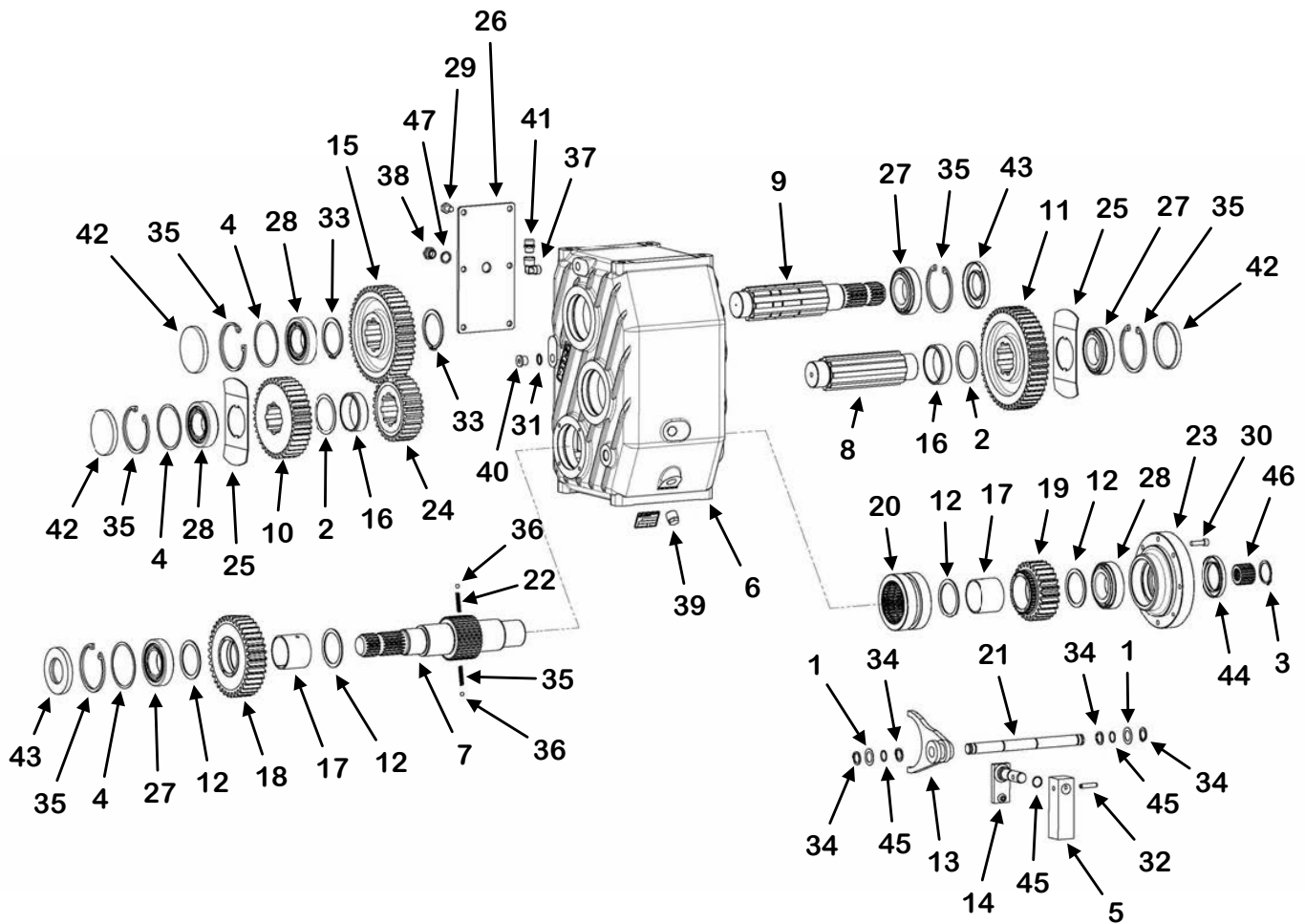

119-2SP-1.5-2.7-1

KEY	PART NUMBER	QTY	DESCRIPTION
27	119-2SP-C-107	3	Roller Bearing
28	119-2SP-C-130	3	Roller Bearing
29	119-2SP-C-43	6	M10 x 16mm Bolt
30	119-2SP-C-131	8	M8 x 300mm Bolt
31	119-2SP-C-111	1	Aluminum Washer
32	119-2SP-C-48	1	Spring Pin
33	119-2SP-C-112	2	Snap Ring
34	119-2SP-C-50	4	Snap Ring
35	119-2SP-C-113	5	Snap Ring
36	119-2SP-C-114	2	Ball
37	119-2SP-C-115	1	90° Elbow
38	119-2SP-C-132	1	Oil Level Indicator Prior to SN 23VM(0585209, 0700208)
	119-2SP-C-145	1	Oil Level Indicator SN 23VM(0585209, 0700208) & Later
39	119-2SP-C-117	1	1/2" Plug
40	119-2SP-C-118	1	3/8" Plug
41	119-2SP-C-119	1	3/8" Breather Plug
42	119-2SP-C-66	3	Cap
43	119-2SP-C-120	2	Double Lip Seal
44	119-2SP-C-121	1	Dust Lip Prior to SN 23VM(0585209, 0700208)
	119-2SP-C-146	1	Dust Lip SN 23VM(0585209, 0700208) & Later
45	119-2SP-C-74	3	O-Ring
46	119-2SP-C-133	1	Joint
47	119-2SP-C-111	1	Aluminum Washer Prior to SN 23VM(0585209, 0700208)
	119-2SP-C-144	1	Aluminum Washer SN 23VM(0585209, 0700208) & Later

KEY	PART NUMBER	QTY	DESCRIPTION
0	119-2SP-1.0-1.5-6K	1	2-Speed Shifting Gearbox 1.00:1/1.50:1 1.75-20 Spline
1	119-2SP-C-1	2	Shim Kit
2	119-2SP-C-83	1	Shim
3	119-2SP-C-74	3	O-Ring
4	119-2SP-C-85	3	Shim Kit
5	119-2SP-C-86	2	Shim
6	119-2SP-C-30	1	Outer Lever
7	119-2SP-C-87	1	Shaft
8	119-2SP-C-88	1	Middle Shaft
9	119-2SP-C-89	1	Shaft
10	119-2SP-C-90	2	Gear
11	119-2SP-C-91	4	Thrust Washer
12	119-2SP-C-92	1	Fork
13	119-2SP-C-93	1	Inner Lever
14	119-2SP-C-94	1	Gear
15	119-2SP-C-95	1	Crown Wheel
16	119-2SP-C-96	1	Spacer
17	119-2SP-C-97	2	Bushing
18	119-2SP-C-98	1	Gear
19	119-2SP-C-99	1	Slide Gear
20	119-2SP-C-100	1	Gear Selector Rod
21	119-2SP-C-101	2	Spring
22	119-2SP-C-102	3	Cover
23	119-2SP-C-103	1	Cover
24	119-2SP-C-104	1	Casing
25	119-2SP-C-105	2	Lubricating Sheet
26	119-2SP-C-106	1	Cover
27	119-2SP-C-107	2	Roller Bearing
28	119-2SP-C-108	4	Bearing
29	119-2SP-C-109	8	M8 x 22mm Bolt
30	119-2SP-C-43	6	M10 x 16 Bolt
31	119-2SP-C-110	18	M8 x 20 mm Bolt
32	119-2SP-C-111	1	Aluminum Washer
33	119-2SP-C-46	1	Aluminum Washer
34	119-2SP-C-48	1	Spring Pin

F2 STOP & SHIFT GEARBOX (CONT'D)

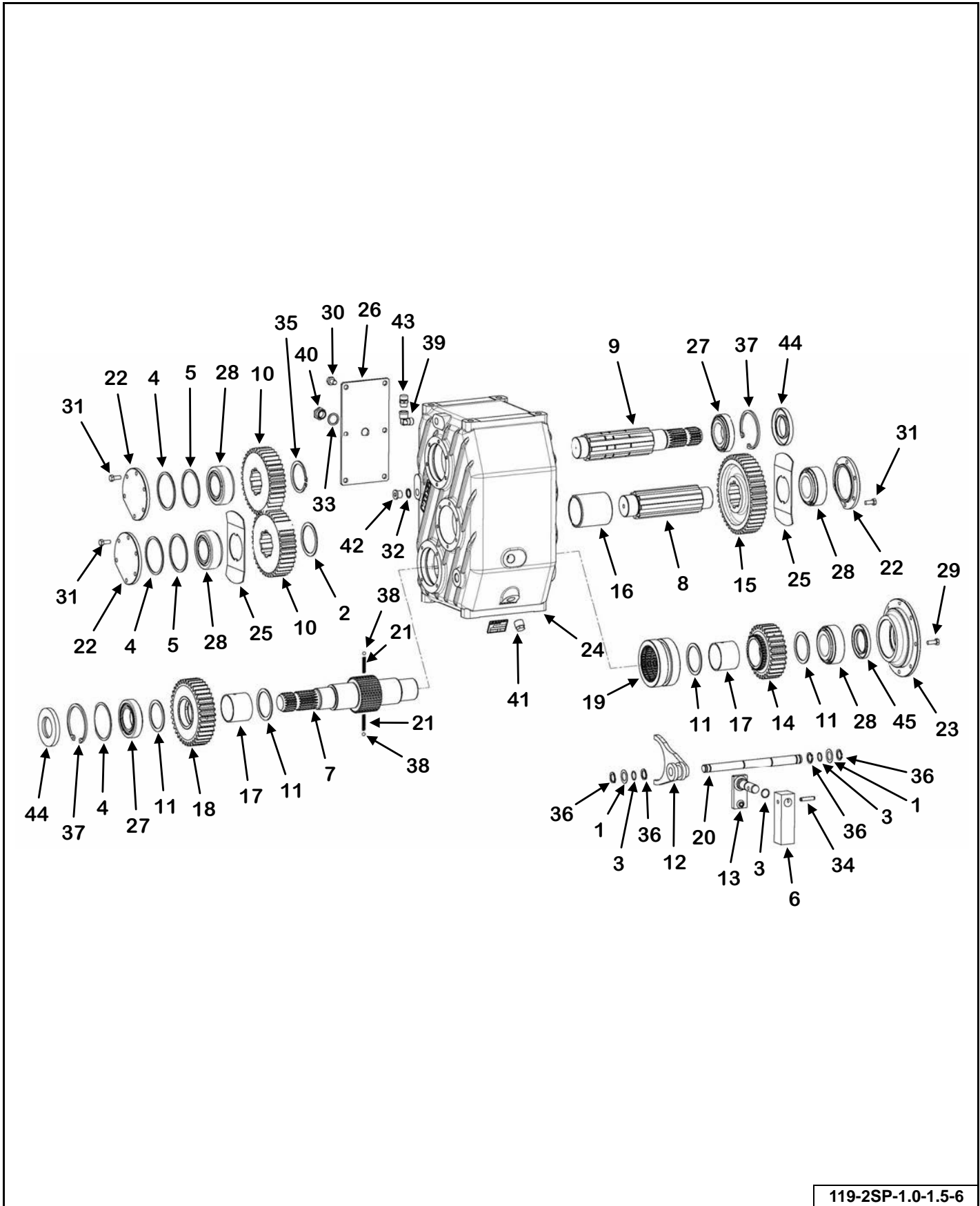

119-2SP-1.0-1.5-6

KEY	PART NUMBER	QTY	DESCRIPTION
35	119-2SP-C-112	1	Snap Ring
36	119-2SP-C-50	4	Snap Ring
37	119-2SP-C-113	2	Snap Ring
38	119-2SP-C-114	2	Ball
39	119-2SP-C-115	1	90° Elbow
40	119-2SP-C-116	1	Oil Level Indicator
41	119-2SP-C-117	1	1/2" Plug
42	119-2SP-C-118	1	3/8" Plug
43	119-2SP-C-119	1	3/8" Breather Plug
44	119-2SP-C-120	2	Double Lip Seal
45	119-2SP-C-121	1	Dust Lip
NS	M11-13-0011	1	Gearbox Pump Cover
	M11-13-0012	1	Gearbox Pump Cover Seal
	851-M10-1.5-20-Z	3	M1-1.5 x 20MM Hex Head Cap Screw

F2 POWER SHIFT TRANSMISSION

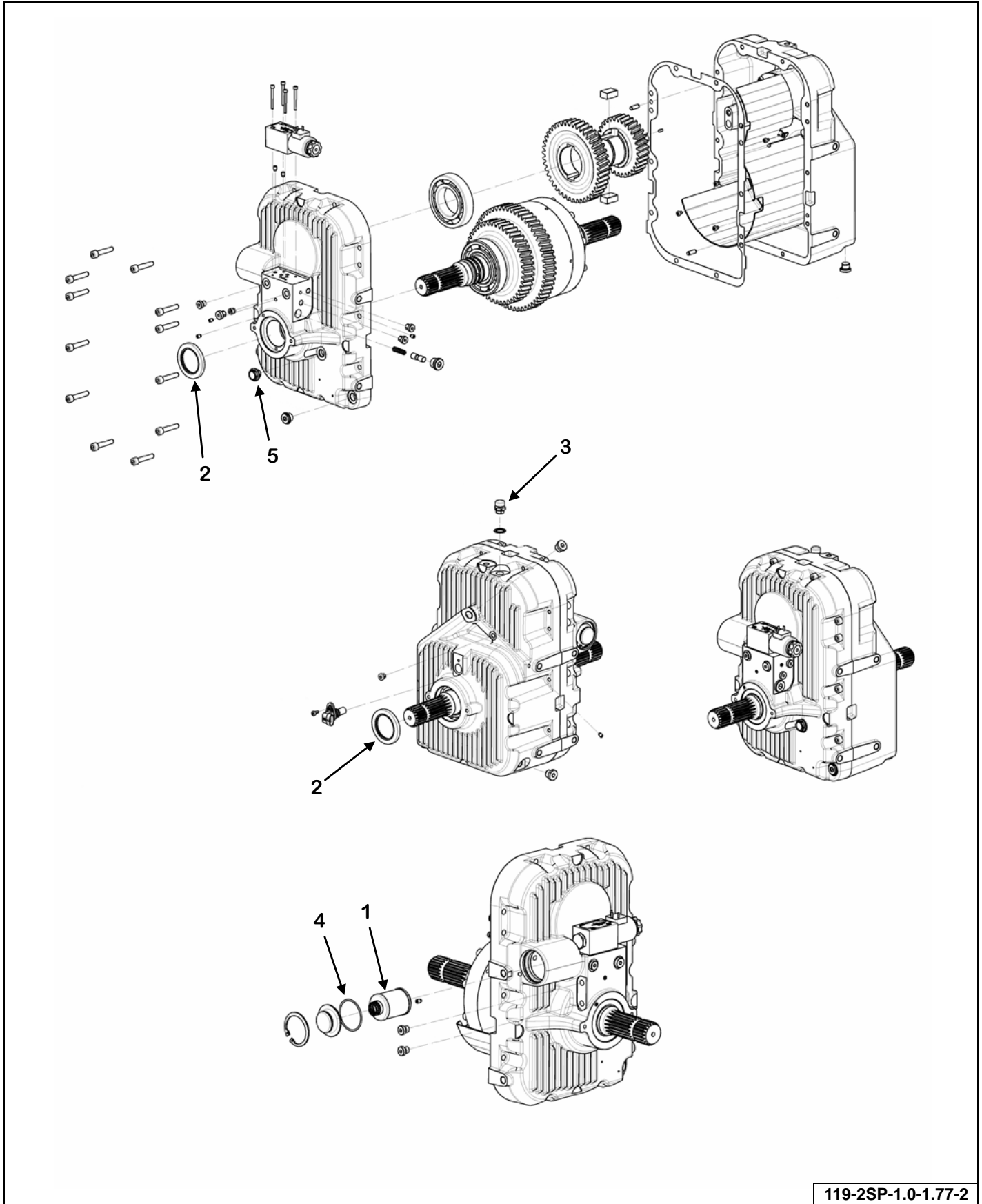

119-2SP-1.0-1.77-2

KEY	PART NUMBER	QTY	DESCRIPTION
0	119-2SP-1.0-1.77-2	1	Zuidberg 2-Speed Automatic Transmission
1	119-Z-01	1	Filter Housing With Filter Element
	119-Z-26-1	1	Filter Element Only
2	119-Z-33	2	Oil Seal
3	119-Z-32	1	Breather Plug Valve
4	119-Z-29	1	O-Ring
5	119-Z-25	1	Oil Level Sight Glass

1800 SERIES PLANETARY
MODELS: 585 / 700

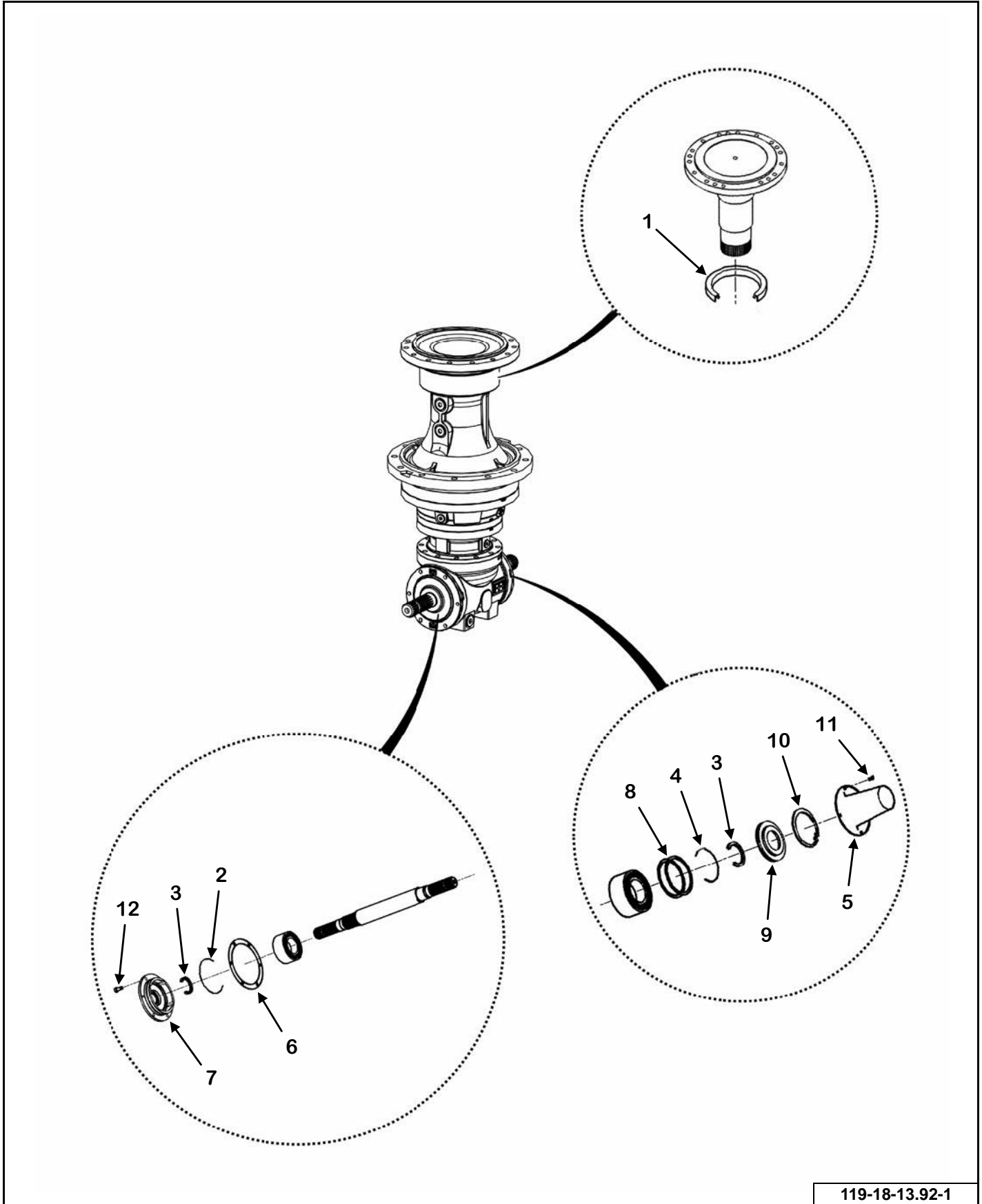

119-18-13.92-1

KEY	PART NUMBER	QTY	DESCRIPTION
0	119-18-13.92-1	2	1800 Series Planetary Gearbox
1	119-P-RR-1	1	Oil Seal
2	119-P-RR-5	1	O-Ring
3	119-P-RR-6	2	Oil Seal
4	119-P-RR-7	1	O-Ring
5	119-P-RR-13	1	Shaft Protection Shield
6	119-P-RR-14	2	Thickness Kit
7	119-P-RR-15	1	Cover
8	119-P-RR-16	2	Thickness Kit
9	119-P-RR-17	1	Cover
10	119-P-RR-18	1	Snap Ring
11	851-M5-.8-10-YZ	4	Cap Screw
12	851-M10-1.5-25-Z	6	Machine Bolt

2100 SERIES PLANETARY
MODELS: F2-585 / F2-700

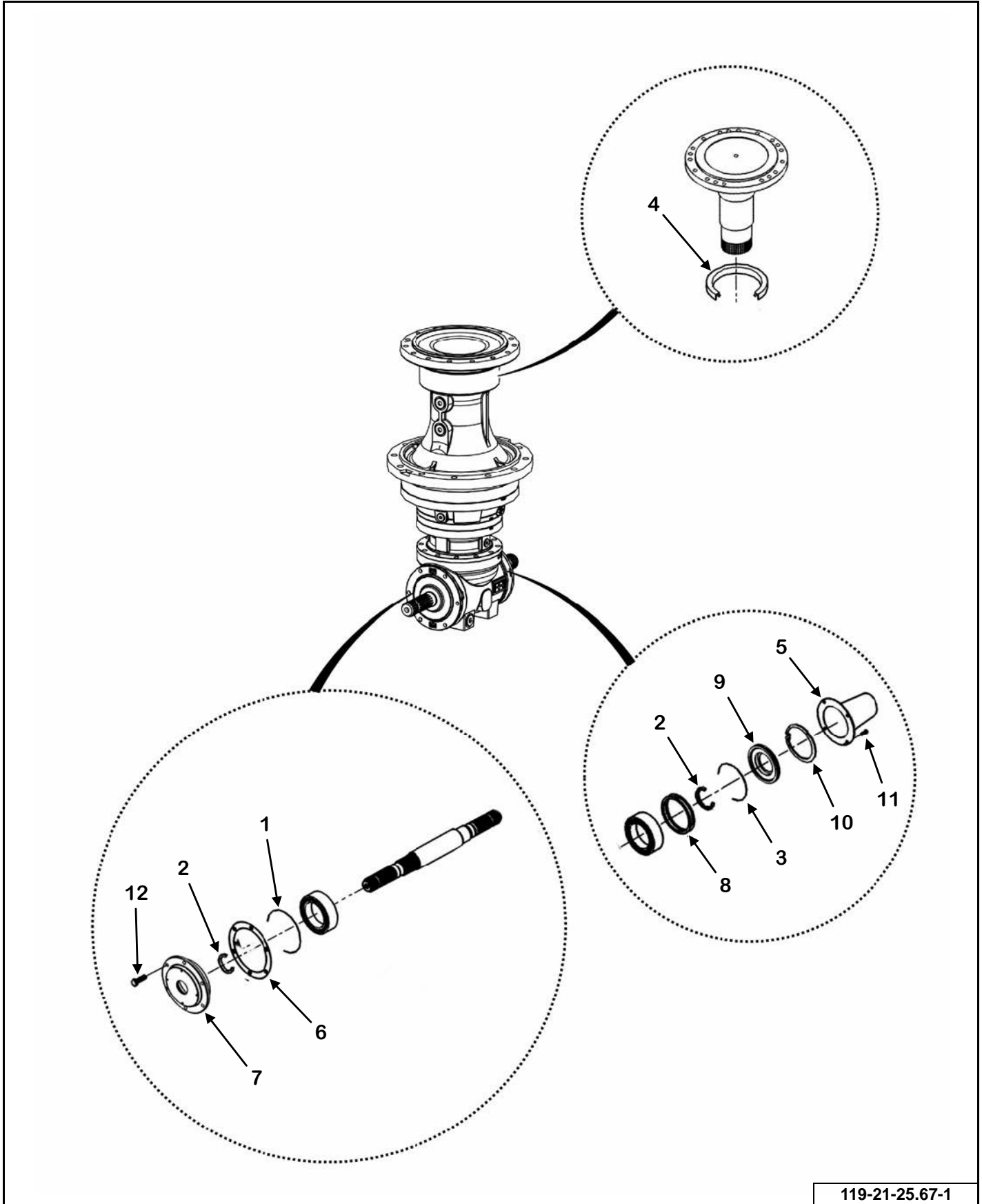

119-21-25.67-1

KEY	PART NUMBER	QTY	DESCRIPTION
0	119-21-25.67-1	2	2100 Series Planetary Gearbox
1	119-P-RR-5	1	O-Ring
2	119-P-RR-6	2	Oil Seal
3	119-P-RR-7	1	O-Ring
4	119-P-RR-1	1	Oil Seal
5	119-P-RR-13	1	Shaft Protection Shield
6	119-P-RR-14	1	Thickness Kit
7	119-P-RR-15	1	Cover
8	119-P-RR-16	2	Thickness Kit
9	119-P-RR-17	1	Cover
10	119-P-RR-18	1	Snap Ring
11	851-M5-.8-10-YZ	4	Cap Screw
12	851-M10-1.5-25-Z	6	Machine Bolt

KEY	PART NUMBER	QTY	DESCRIPTION	MIXER MODEL
1	155-2231-08	108"	1/2" ID x 3/4" OD Push On Hose, Rear	585/700
2	155-2231-08	121"	1/2" ID x 3/4" OD Push On Hose	585/700
3	155-2231-08	130"	1/2" ID x 3/4" OD Push On Hose	585/700
4	952-0003	2	2 QT Plastic Tank With Vented Cap	585/700
5	55-0403	2	1/2" x 1/4" BRS 90° Elbow	585/700
6	55-0404	2	1/2" x 3/8" BRS MA Barb Hose	585/700
7	55-0405	2	1/2" x 3/8" BRS MA Barb Hose	585/700
8	See Page 178	2	1800 Planetary Gearbox 13.92:1 Ratio 1.75-20 SPL	585/700
9	155-PB4-4	2	#4NPT FEMx4BSPP Adapter With BSP Bonded Seal	585/700
10	155-PB12-12	2	#12NPT FEMx12BSPP Adapter W/BSP Bonded Seal	585/700
11	155-5406-12-6	2	12MP-6FP Pipe Reducer Bushing 3/4"-3/8"	585/700
12	55-0307	2	Breather Vent 3/8" Pipe x 11/16" Hex 150 PSI	585/700
13	55-0404	2	1/2" x 3/8" BRS 90° Elbow Barb	585/700
14	155-2231-08	108"	1/2" ID x 3/4" OD Push On Hose	585/700

F2 PLANETARY GEARBOX OIL SYSTEM

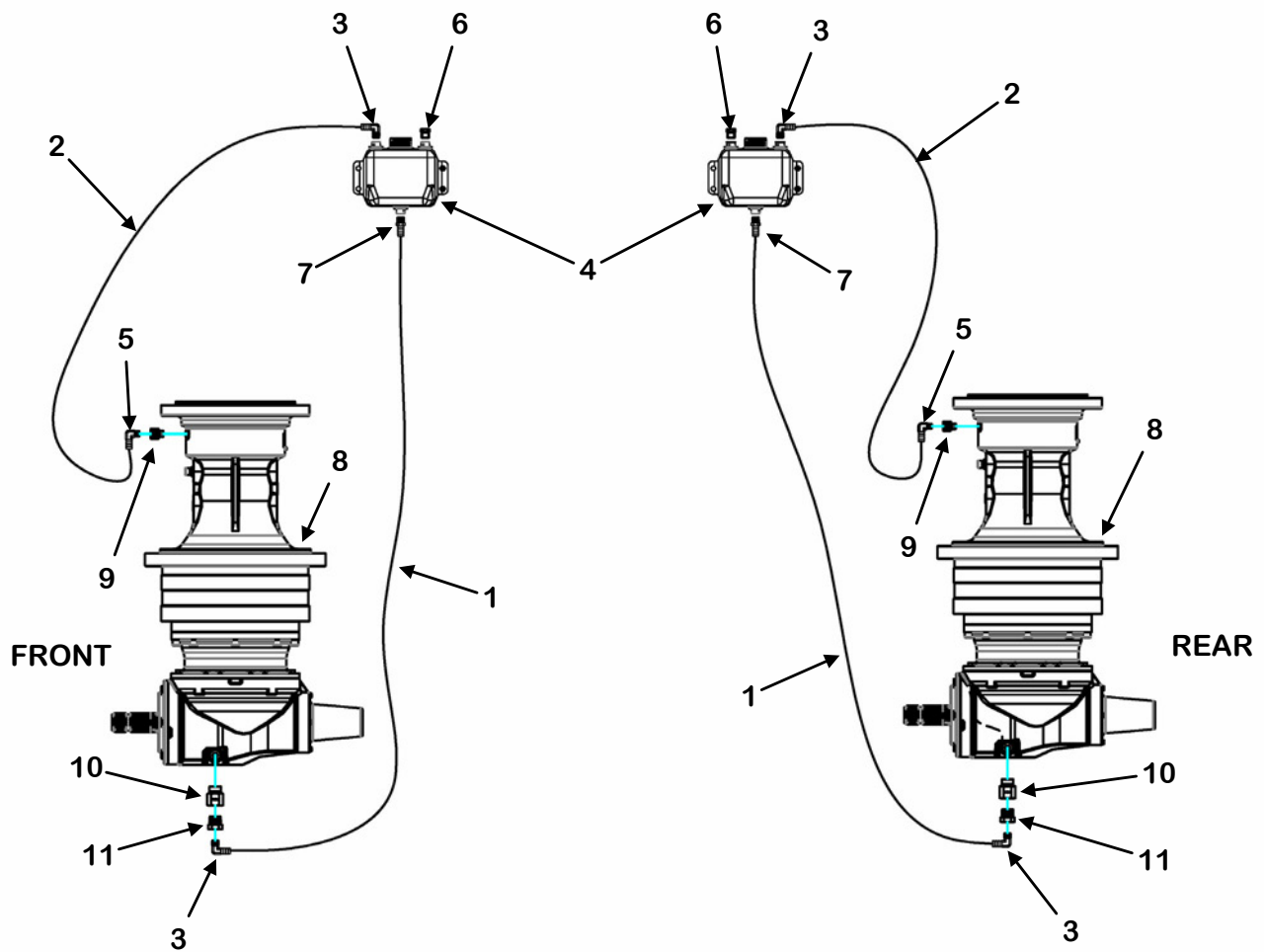

Use #48-0081 Synthetic
ISO220 or Equivalent For
Planetary Gearboxes.

FM-M-0012-1

KEY	PART NUMBER	QTY	DESCRIPTION	MIXER MODEL
1	155-08-6-110	2	1/2" x 110" Push On Hose	F2-585/F2-700
2	155-08-6-122	2	1/2" x 122" Push On Hose	F2-585/F2-700
3	55-0404	4	1/2" x 3/8" BRS 90° Elbow Barb	F2-585/F2-700
4	952-0003	2	2 QT Plastic Tank With Vented Cap	F2-585/F2-700
5	55-0403	2	1/2" x 1/4" NPT 90° Elbow Barb	F2-585/F2-700
6	55-0307	2	Breather Vent 3/8" Pipe x 11/16" Hex 150 PSI	F2-585/F2-700
7	55-0405	2	1/2" x 3/8" BRS MA Barb Hose	F2-585/F2-700
8	See Page 180	2	2100 Planetary Gearbox 25.67:1 Ratio 1.75-20 SPL	F2-585/F2-700
9	155-PB4-4	2	#04NPT FEMx04BSPP Adapter With BSP Bonded Seal	F2-585/F2-700
10	155-PB12-12	2	#12NPT FEMx12BSPP Adapter W/BSP Bonded Seal	F2-585/F2-700
11	155-5406-12-6	2	12MP-06FP Pipe Reducer Bushing 3/4"-3/8"	F2-585/F2-700

KEY	PART NUMBER	QTY	DESCRIPTION	MIXER MODEL
1	155-2231-08	31"	1/2" ID x 3/4" OD Push On Hose	585/700
2	55-0307	1	Breather Vent 3/8" 150 PSI	585/700
3	See Page 168	1	2-Speed Shifting Gearbox 1.51:1/2.73:1 1.75-20 Spline	585/700
4	55-0406	3	1/2" x 3/8" BRS 90° Elbow Barb	585/700
5	155-PB06-06	1	#06 Female NPT x 06 BSPP Adapter W/BSP Bonded Seal	585/700
6	952-0004	1	4 QT Plastic Tank With Vented Cap	585/700
7	155-2231-08	36"	1/2" ID x 3/4" OD Push On Hose	585/700
8	155-PB08-08	1	#08 Female NPT x 08 BSPP Adapter W/BSP Bonded Seal	585/700
9	55-0410	1	1/2" Hose ID x 1/2" NPT Male Hose Barb	585/700
NS	32-0048	AR	Hose Clamps	585/700

1-3/8-21 SPLINE X 1-3/4-20 SPLINE PTO DRIVE SHAFT

MODELS: 585 / F2-585 / 700 / F2-700

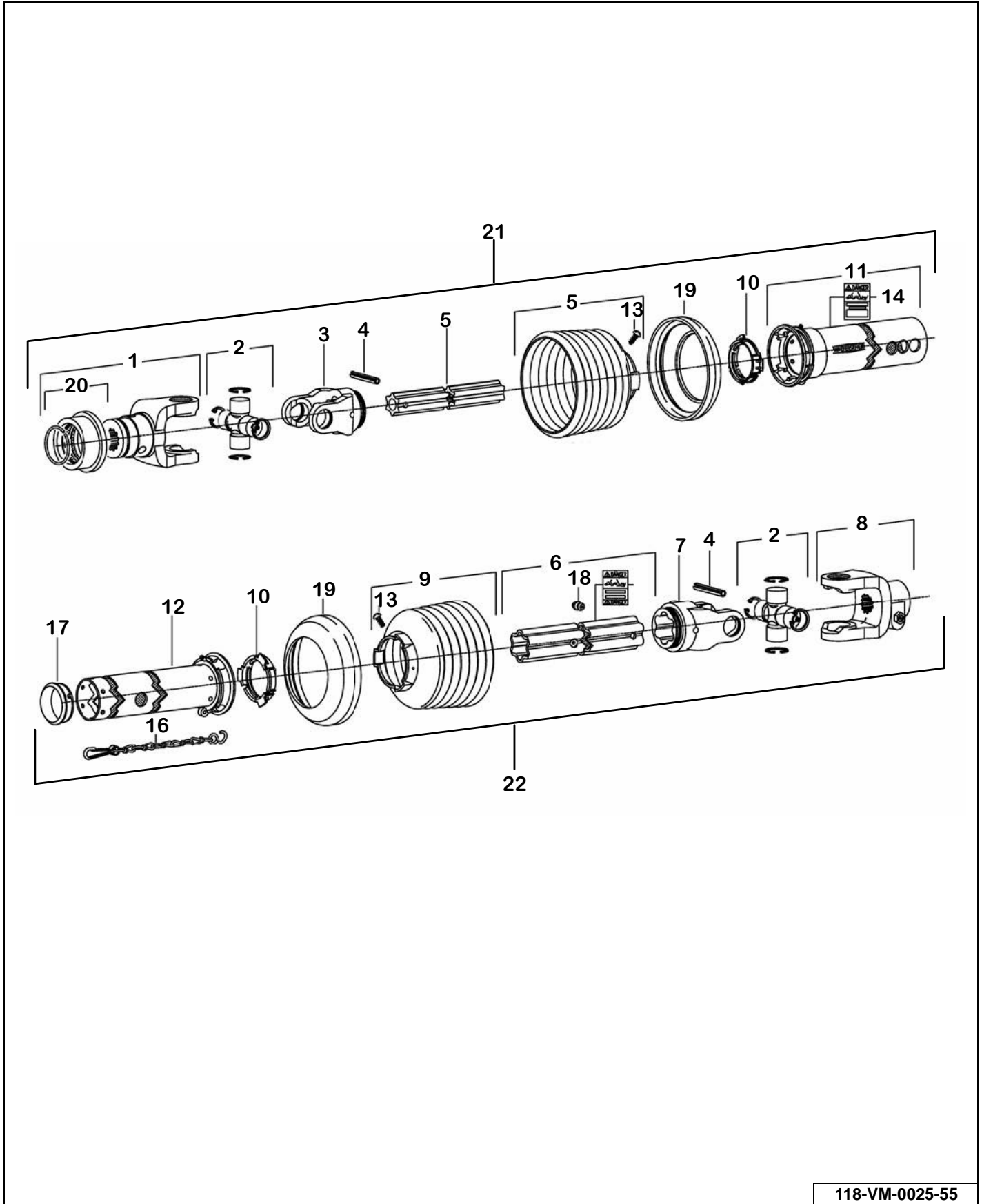

KEY	PART NUMBER	QTY	DESCRIPTION
0	118-VM-0025-55	1	1-3/8-21 Spline PTO Complete
1	118-VM-0025-55-3	1	Yoke Assembly (Includes Item 20)
2	118-VM-0010-25-2	2	Cross & Bearing Kit
3	618-0202-2-2	1	Inboard Yoke
4	618-0202-2-5	2	Spring Pin, 10 x 90
5	118-VM-0024-55-3	1	Inner Profile
6	118-VM-0024-55-4	1	Outer Profile (Includes Items 15 & 18)
7	618-0201-2-2	1	Inboard Yoke
8	118-VM-0010-25-1	1	Yoke AGKF
9	118-VM-0024-55-7	2	Guard Cone, 7 Rib (Includes Item 13)
10	918-0208-2-4	2	Bearing Ring
11	118-VM-0025-55-4	1	Guard Tube Outer (Includes Item 14)
12	118-VM-0024-55-6	1	Guard Tube Inner
13	918-0208-2-9	2	Screw
14	918-0208-2-8	1	Decal Outer
15	918-0208-1-10	1	Decal Inner
16	918-0208-2-7	1	Restraint Chain
17	918-0202-1-10	1	Support Bearing
18	918-0202-1-12	1	Zerk
19	618-0202-2-8	2	Reinforcing Collar
20	918-0511-1-1-1	1	ASG Collar Kit
21	118-VM-0025-55-1	1	Tractor Half Shaft
22	118-VM-0024-55-2	1	Implement Half Shaft

1-3/4-20 SPLINE X 1-3/4-20 SPLINE PTO DRIVE SHAFT (OPTIONAL)

MODELS: 585 / F2-585 / 700 / F2-700

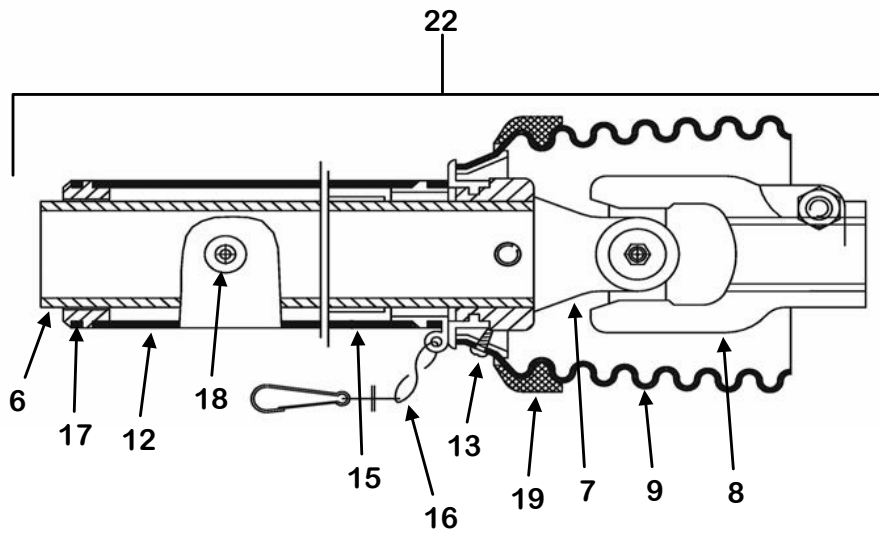
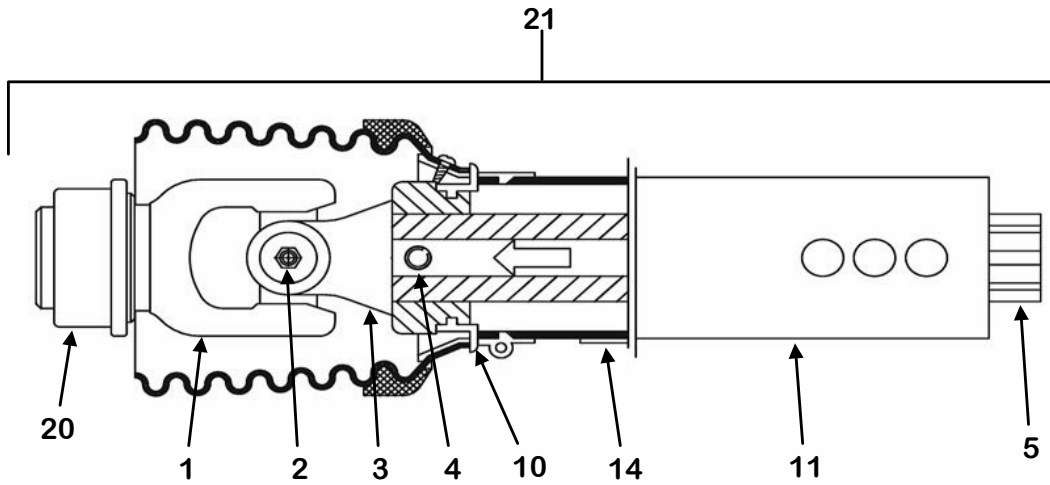

118-VM-0026-55

KEY	PART NUMBER	QTY	DESCRIPTION
0	118-VM-0026-55	1	1-3/4"-20 Spline PTO Complete
1	618-0201-1-1	1	Yoke ASG (Includes Item 20)
2	118-VM-0010-25-2	2	Cross & Bearing Kit
3	618-0202-2-2	1	Inboard Yoke
4	618-0202-2-5	2	Spring Pin, 10 x 90
5	118-VM-0026-55-3	1	Inner Profile
6	118-VM-0024-55-4	1	Outer Profile (Includes Items 15 & 18)
7	618-0201-2-2	1	Inboard Yoke
8	118-VM-0010-25-1	1	Yoke AGKF
9	118-VM-0024-55-7	2	Guard Cone, 7 Rib (Includes Item 13)
10	918-0208-2-4	2	Bearing Ring SC25
11	118-VM-0026-55-4	1	Guard Tube Outer (Includes Item 14)
12	118-VM-0024-55-6	1	Guard Tube Inner
13	918-0208-2-9	2	Screw
14	918-0208-2-8	1	Decal Outer
15	918-0208-1-10	1	Decal Inner
16	918-0208-1-12	1	Restraint Chain
17	618-0202-1-10	1	Support Bearing
18	918-0208-1-12	1	Zerk
19	618-0202-2-8	2	Reinforcing Collar
20	918-0210-1-1-1	1	ASG Collar Kit
21	118-VM-0026-55-1	1	Tractor Half Shaft
22	118-VM-0024-55-2	1	Implement Half Shaft

1-3/8-21 SPLINE X 1-3/4-20 SPLINE CV PTO DRIVE SHAFT (OPTIONAL)

MODELS: 585 / F2-585 / 700 / F2-700 (Optional)

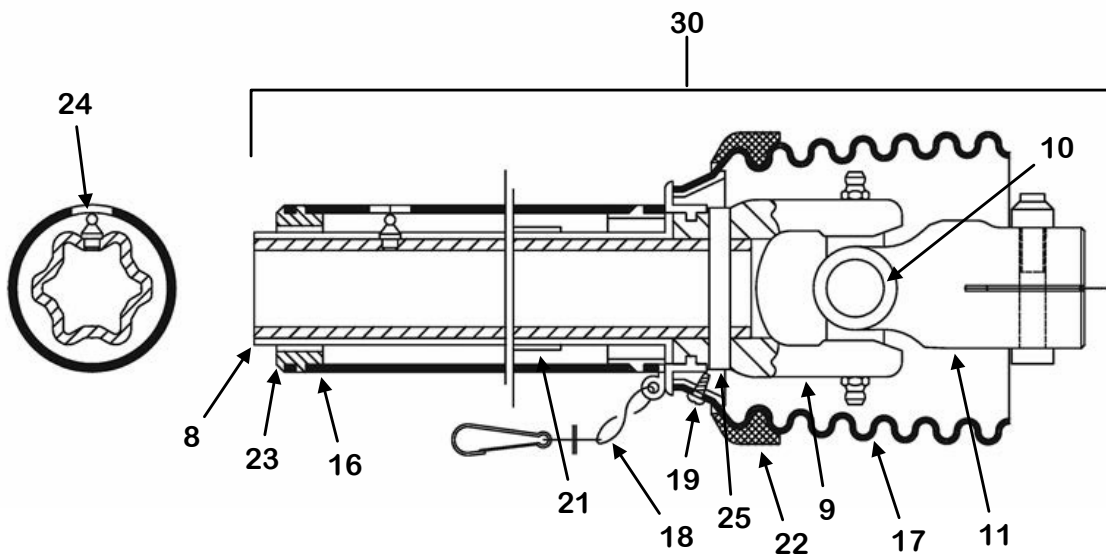
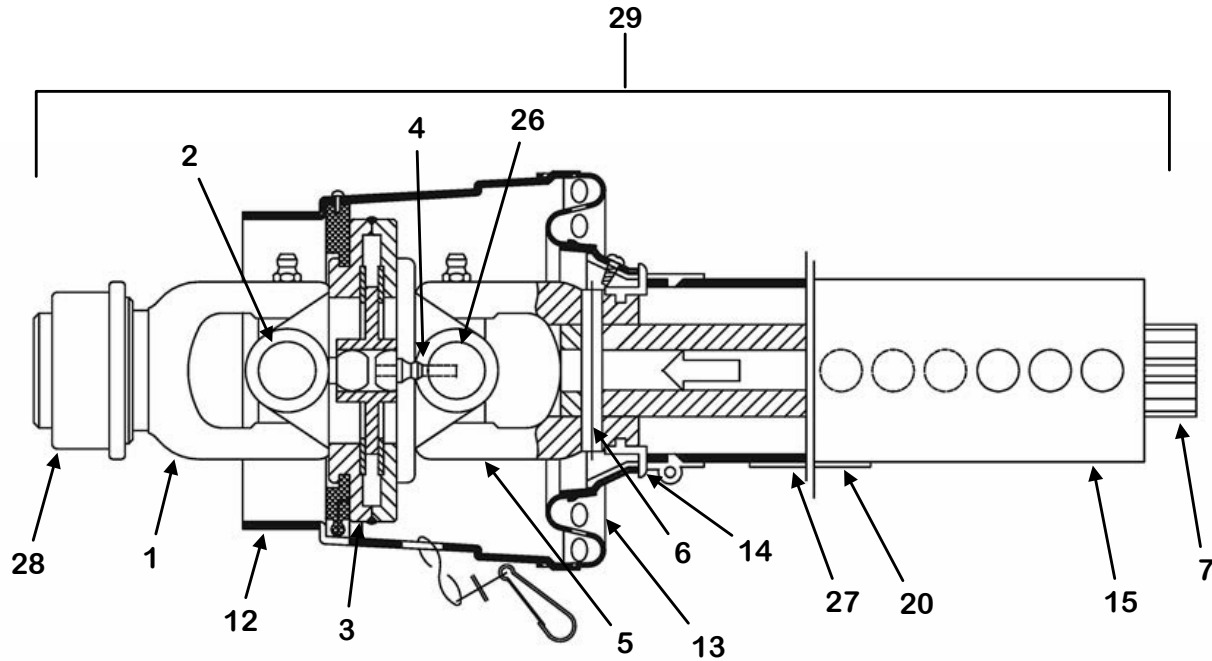

118-VM-0023-55

KEY	PART NUMBER	QTY	DESCRIPTION
0	118-VM-0023-55	1	1-3/8"-21 Spline CV PTO Complete
1	918-0511-1-1	1	Yoke ASG (Includes Item 28)
2	918-0511-1-2	1	Cross & Bearing Kit
3	918-0511-1-3	1	Double Yoke (Includes Item 4)
4	918-0208-1-2	1	Zerk
5	918-0511-1-5	1	Inboard Yoke
6	918-0308-1-5	1	Spring Pin, 10 x 75
7	118-VM-0024-55-3	1	Inner Profile
8	118-VM-0024-55-4	1	Outer Profile (Includes Items 21 & 24)
9	618-0201-2-2	1	Inboard Yoke
10	118-VM-0010-25-2	1	Cross & Bearing Kit
11	118-VM-0010-25-1	1	Yoke 1-3/4"-20 SPL
12	618-0202-1-11	1	CV Guard & Bearing Assembly (Includes Items 14 & 19)
13	918-0212-1-5	1	Flex Net & Guard Assembly (Includes Item 19)
14	918-0208-2-4	2	Bearing Ring
15	118-VM-0024-55-5	1	Guard Tube Outer (Includes Item 20)
16	118-VM-0024-55-6	1	Guard Tube Inner
17	118-VM-0024-55-7	1	Guard Cone, 7 Rib (Includes Item 19)
18	918-0208-2-7	2	Restraint Chain
19	918-0208-2-9	10	Screw
20	918-0208-2-8	1	Decal Outer
21	918-0208-1-10	1	Decal Inner
22	618-0202-2-8	1	Reinforcing Collar
23	618-0202-1-10	1	Support Bearing
24	918-0208-1-12	1	Zerk
25	618-0202-2-5	1	Spring Pin, 10 x 90
26	918-0511-1-4	1	Cross & Bearing Kit
27	918-0308-2-6	1	Decal, Lubrication
28	918-0511-1-1-1	1	ASG Collar Kit
29	118-VM-0023-55-1	1	Tractor Half Shaft
30	118-VM-0024-55-2	1	Implement Half Shaft

1-3/4-20 SPLINE X 1-3/4-20 SPLINE CV PTO DRIVE SHAFT (OPTIONAL)

MODELS: 585 / F2-585 / 700 / F2-700 (Optional)

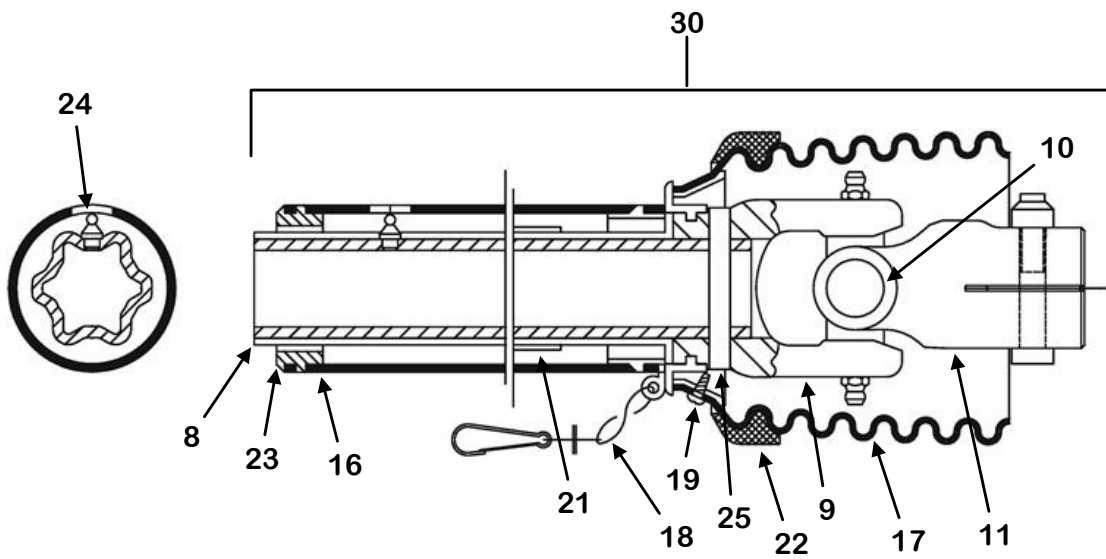
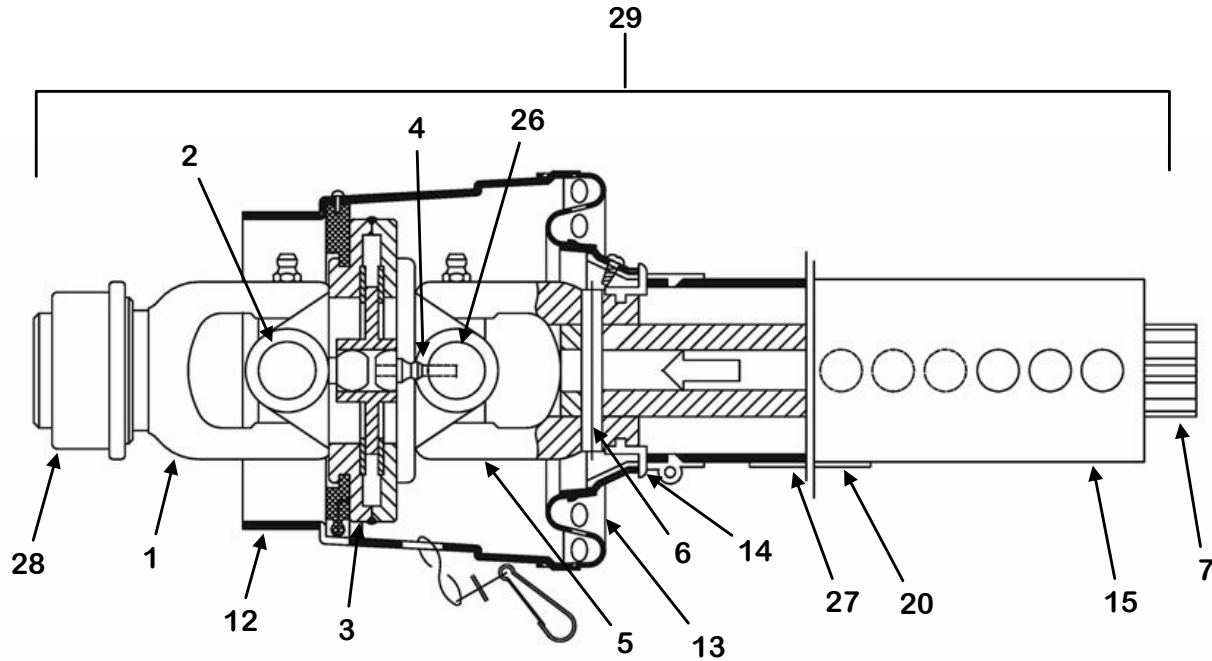

118-VM-0024-55

KEY	PART NUMBER	QTY	DESCRIPTION
0	118-VM-0024-55	1	1-3/4"-20 Spline CV PTO Complete
1	918-0512-1-1	1	Yoke ASG (Includes Item 28)
2	918-0511-1-2	1	Cross & Bearing Kit
3	918-0511-1-3	1	Double Yoke (Includes Item 4)
4	918-0208-1-2	1	Zerk
5	918-0511-1-5	1	Inboard Yoke
6	918-0308-1-5	1	Spring Pin, 10 x 75
7	118-VM-0024-55-3	1	Inner Profile
8	118-VM-0024-55-4	1	Outer Profile (Includes Items 21 & 24)
9	618-0201-2-2	1	Inboard Yoke
10	118-VM-0010-25-2	1	Cross & Bearing Kit
11	118-VM-0010-25-1	1	Yoke 1-3/4"-20 SPL
12	618-0202-1-11	1	CV Guard & Bearing Assembly (Includes Item 19)
13	918-0212-1-5	1	Flex Net & Guard Assembly (Includes Item 19)
14	918-0208-2-4	2	Bearing Ring SC25
15	118-VM-0024-55-5	1	Guard Tube Outer (Includes Item 20)
16	118-VM-0024-55-6	1	Guard Tube Inner
17	118-VM-0024-55-7	1	Guard Cone, 7 Rib (Includes Item 19)
18	918-0208-2-7	2	Restraint Chain
19	918-0208-2-9	10	Screw
20	918-0208-2-8	1	Decal Outer
21	918-0208-1-10	1	Decal Inner
22	618-0202-2-8	1	Reinforcing Collar
23	618-0202-1-10	1	Support Bearing
24	618-0208-1-12	1	Zerk
25	618-0202-2-5	1	Spring Pin, 10 x 90
26	918-0511-1-4	1	Cross & Bearing Kit
27	918-0308-2-6	1	Decal, Lubrication
28	918-0210-1-1-1	1	ASG Collar Kit
29	118-VM-0024-55-1	1	Tractor Half Shaft
30	118-VM-0024-55-2	1	Implement Half Shaft

1-3/4-20 SPLINE X 1-3/4-20 SPLINE PTO DRIVE SHAFT
MODELS: F2-585/F2-700

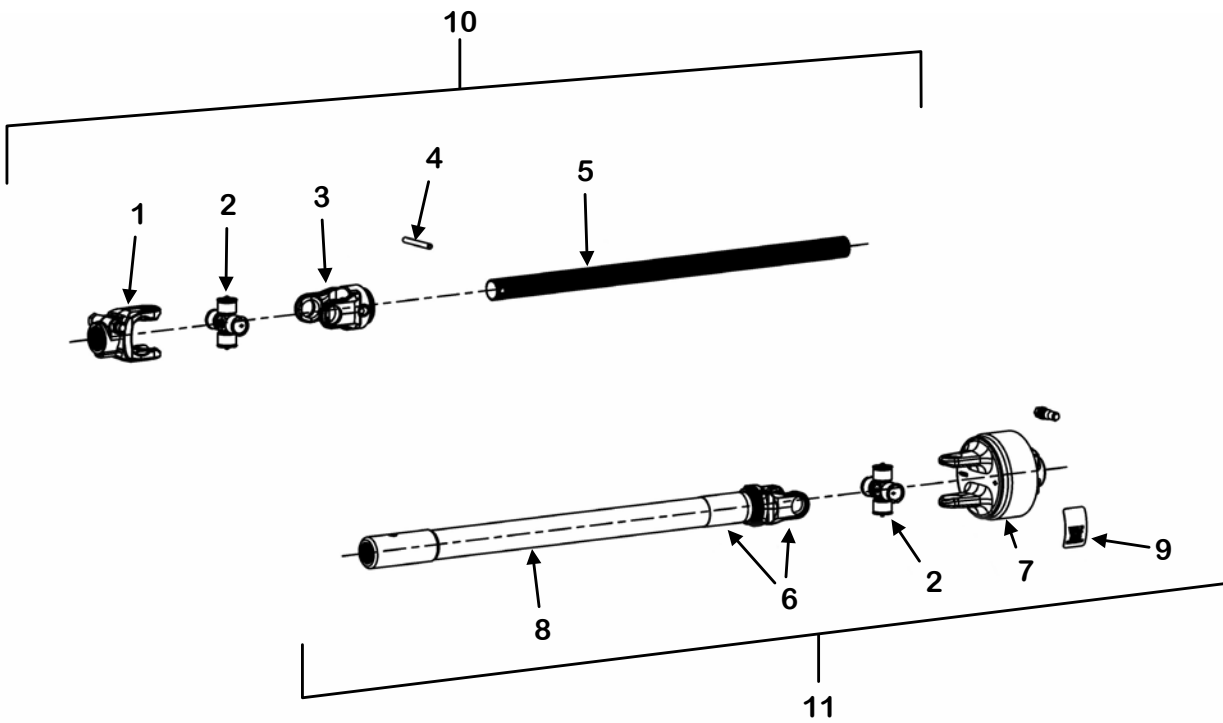

118-VM-0005-2500

KEY	PART NUMBER	QTY	DESCRIPTION
0	118-VM-0005-2500	1	1-3/4"-20 Spline PTO Complete
1	118-VM-0010-25-1	1	Yoke
2	118-VM-0010-25-2	2	Cross & Bearing Kit
3	118-VM-0020-55-3	1	Inboard Yoke
4	618-0202-2-5	1	Spring Pin
5	118-2500-5	1	Inner Profile
6	118-2500-8	1	Inboard Yoke Tube
7	See Page 203	1	Cutout Clutch
8	918-0208-1-10	1	Decal Inner
9	918-0208-2-10	1	Decal
10	118-VM-0005-2500-1	1	Drive Half
11	118-VM-0005-2500-2	1	Planetary Half

1-3/4-20 SPLINE X 1-3/4-20 SPLINE PTO DRIVE SHAFT
 MODELS: F2-585/F2-700

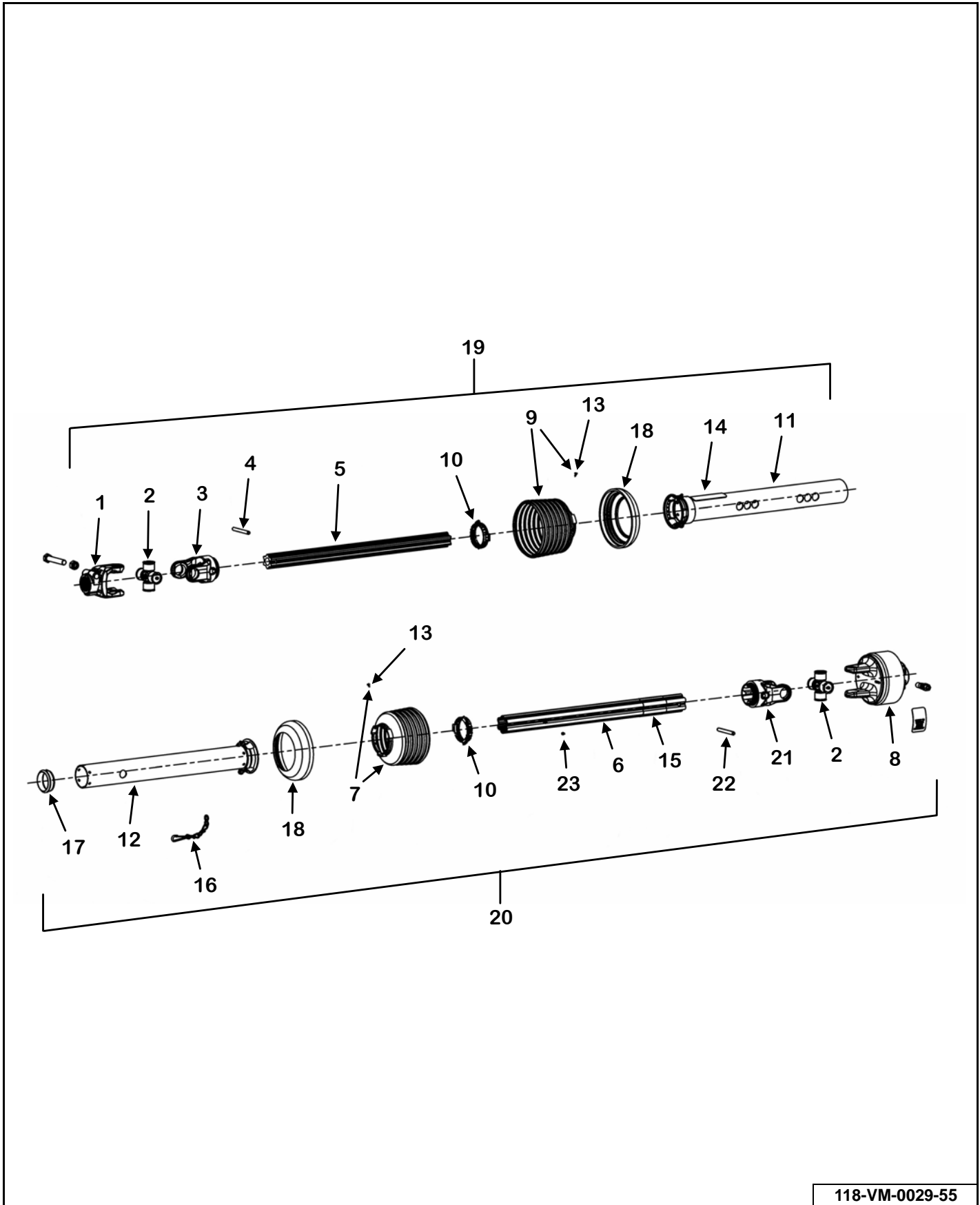

118-VM-0029-55

KEY	PART NUMBER	QTY	DESCRIPTION
0	118-VM-0029-55	1	1-3/4"-20 Spline PTO Complete
1	118-VM-0010-25-1	1	Yoke
2	118-VM-0010-25-2	2	Cross & Bearing Kit
3	618-0202-2-2	1	Inboard Yoke
4	618-0202-2-5	1	Spring Pin
5	118-VM-0024-55-3	1	Inner Profile
6	118-VM-0029-55-3	1	Inboard Yoke Tube
7	618-0202-2-7	1	Guard Cone, 6 Rib (Includes Item 13)
8	See Page 202	1	Cutout Clutch
9	618-0201-2-4	1	Guard Cone, 7 Rib (Includes Item 13)
10	918-0208-2-4	2	Bearing Ring SC25
11	118-VM-0029-55-4	1	Guard Tube Outer
12	118-VM-0029-55-5	1	Guard Tube Inner
13	918-0208-2-9	2	Screw
14	918-0208-2-8	1	Decal Outer
15	918-0208-1-10	1	Decal Inner
16	918-0208-2-7	1	Restraint Chain
17	618-0202-1-10	1	Support Bearing
18	618-0202-2-8	2	Reinforcing Collar
19	118-VM-0029-55-1	1	Power Shift Transmission Half
20	118-VM-0029-55-2	1	Planetary Half
21	618-0201-2-2	1	Inboard Yoke
22	618-0202-2-5	1	Spring Pin
23	918-0208-1-12	1	Grease Zerk

1-3/4-20 SPLINE X 1-3/4-20 SPLINE 2500 SERIES DRIVELINE

MODELS: 585 / 700

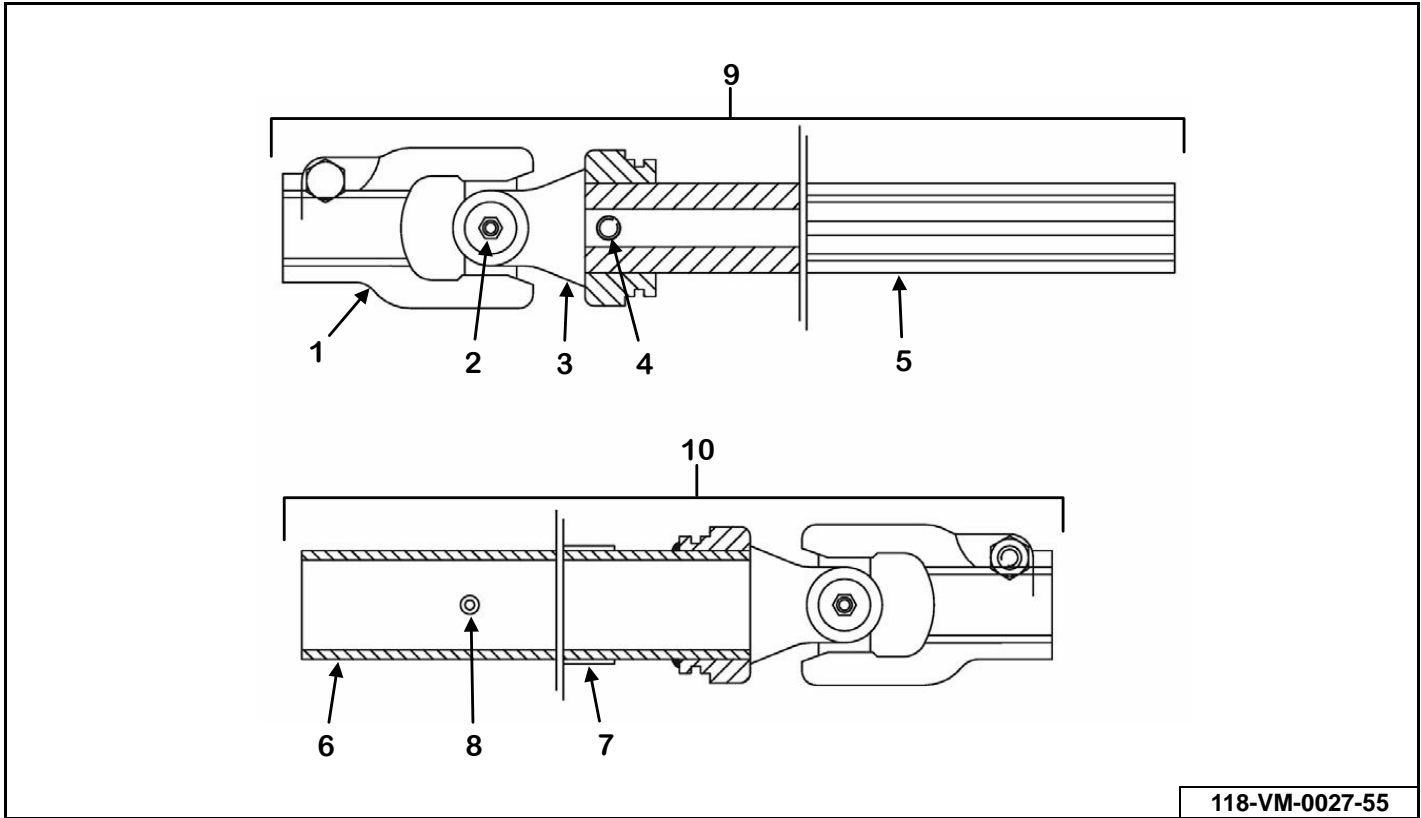

118-VM-0027-55

KEY	PART NUMBER	QTY	DESCRIPTION
0	118-VM-0027-55	1	1-3/4-20 Spline PTO Complete
1	118-VM-0010-25-1	2	Yoke AGKF
2	118-VM-0010-25-2	2	Cross & Bearing Kit
3	618-0202-2-2	1	Inboard Yoke
4	618-0202-2-5	1	Spring pin, 10 x 90
5	118-VM-0027-55-3	1	Inner Profile
6	118-VM-0027-55-4	1	Inboard Yoke (Includes Items 7 & 8)
7	618-0007-6	1	Decal
8	918-0208-1-12	2	Zerk
9	118-VM-0027-55-1	1	Male Half Shaft
10	118-VM-0027-55-2	1	Female Half Shaft

DOUBLE UNIVERSAL JOINT W/CUTOUT CLUTCH

MODELS: 585 / 700

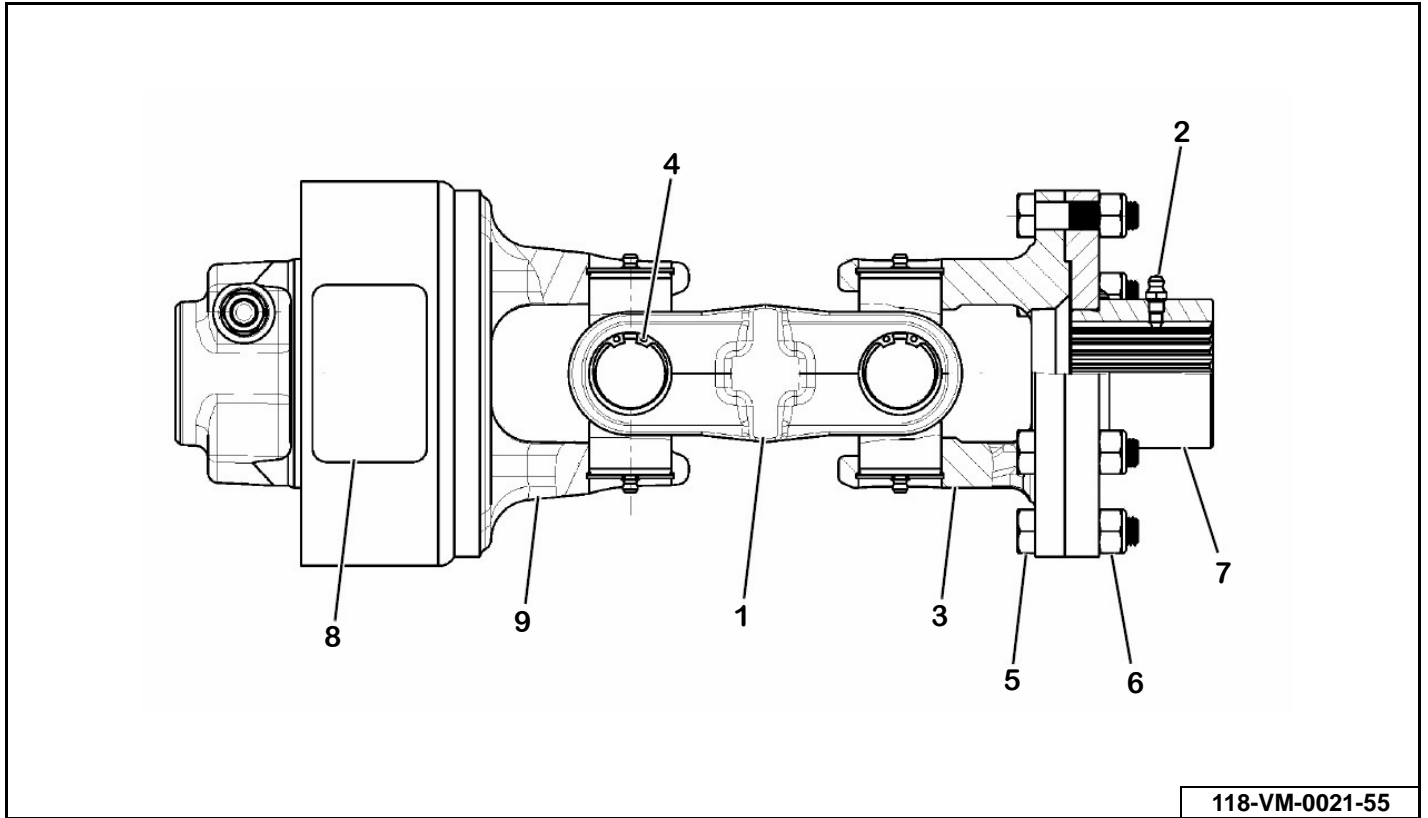

118-VM-0021-55

KEY	PART NUMBER	QTY	DESCRIPTION
0	118-VM-0021-55	1	Double Universal Joint W/Cutout Clutch
1	118-VM-0011-25-1	1	Double Yoke
2	618-0005-1-1	1	Zerk
3	118-VM-0011-25-2	1	Flange Yoke
4	118-VM-0010-25-2	2	Cross Kit (Includes Item CC Lock Kit)
	918-0410-2-1-1	2	CC Lock Kit
5	118-VM-0011-25-3	6	Bolt, M12 x 50
6	118-VM-0011-25-4	6	Nut, Lock
7	118-VM-0011-25-5	1	Hub Flange (Includes Item 2)
8	918-0208-2-10	1	Decal K64
9	See Page 202	1	Cutout Clutch Complete

CUTOUT CLUTCH

MODELS: 585 / F2-585 (Side Discharge) / 700 / F2-700 (Side Discharge)

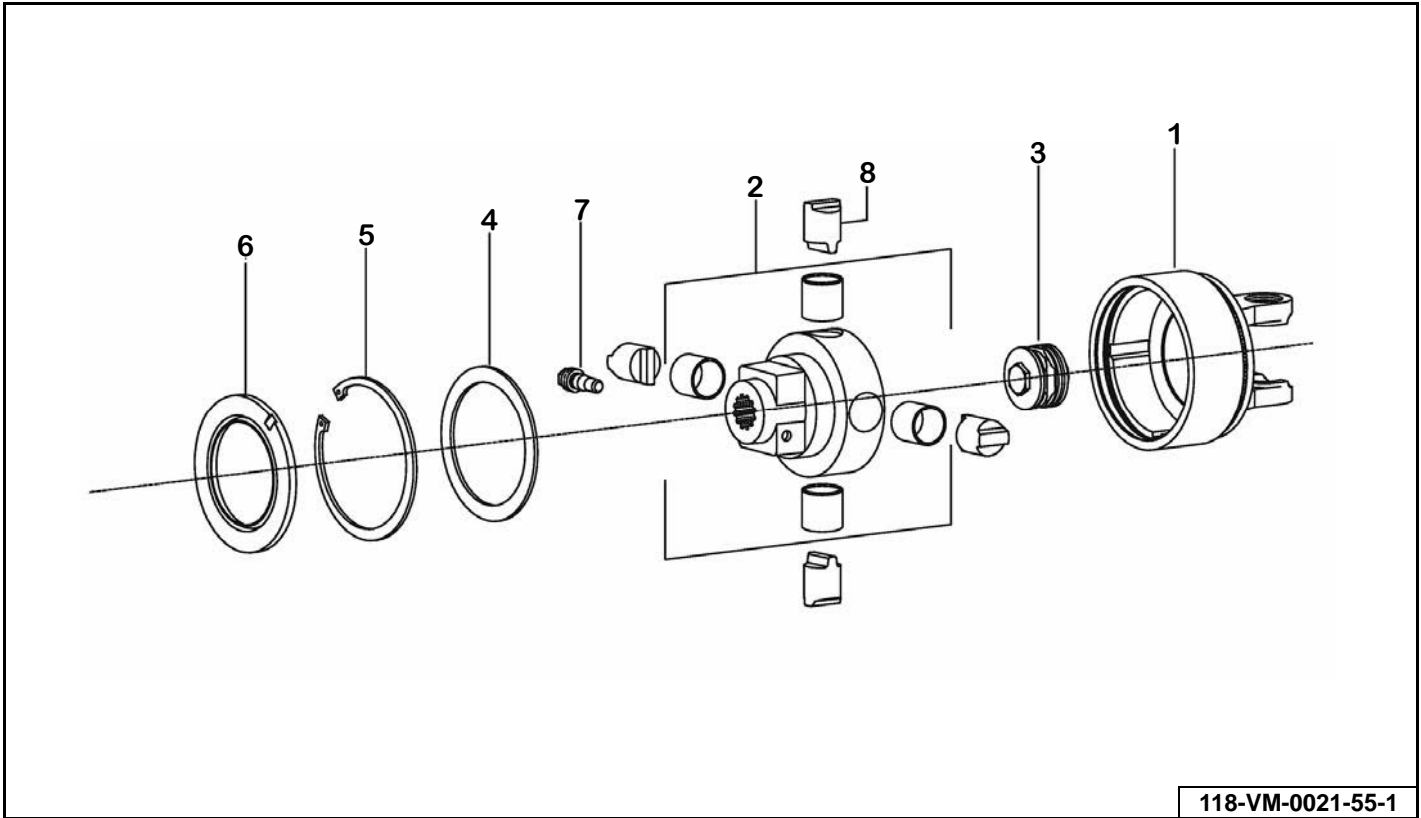

118-VM-0021-55-1

KEY	PART NUMBER	QTY	DESCRIPTION
0	118-VM-0021-55-1	1	Cutout Clutch Complete
1	618-0202-2-3-1	1	Housing
2	118-VM-0021-55-1-1	1	Hub
3	118-VM-0021-55-1-2	1	Spring Pack
4	918-0208-2-3-5	1	Washer
5	918-0208-2-3-6	1	Retaining Ring
6	918-0208-2-3-7	1	Sealing Ring
7	918-0410-2-1-1	1	Clamp Cone Assembly
8	918-0308-2-2-4	4	Cam

CUTOUT CLUTCH

MODELS: F2-585 (Front Discharge) / F2-700 (Front Discharge)

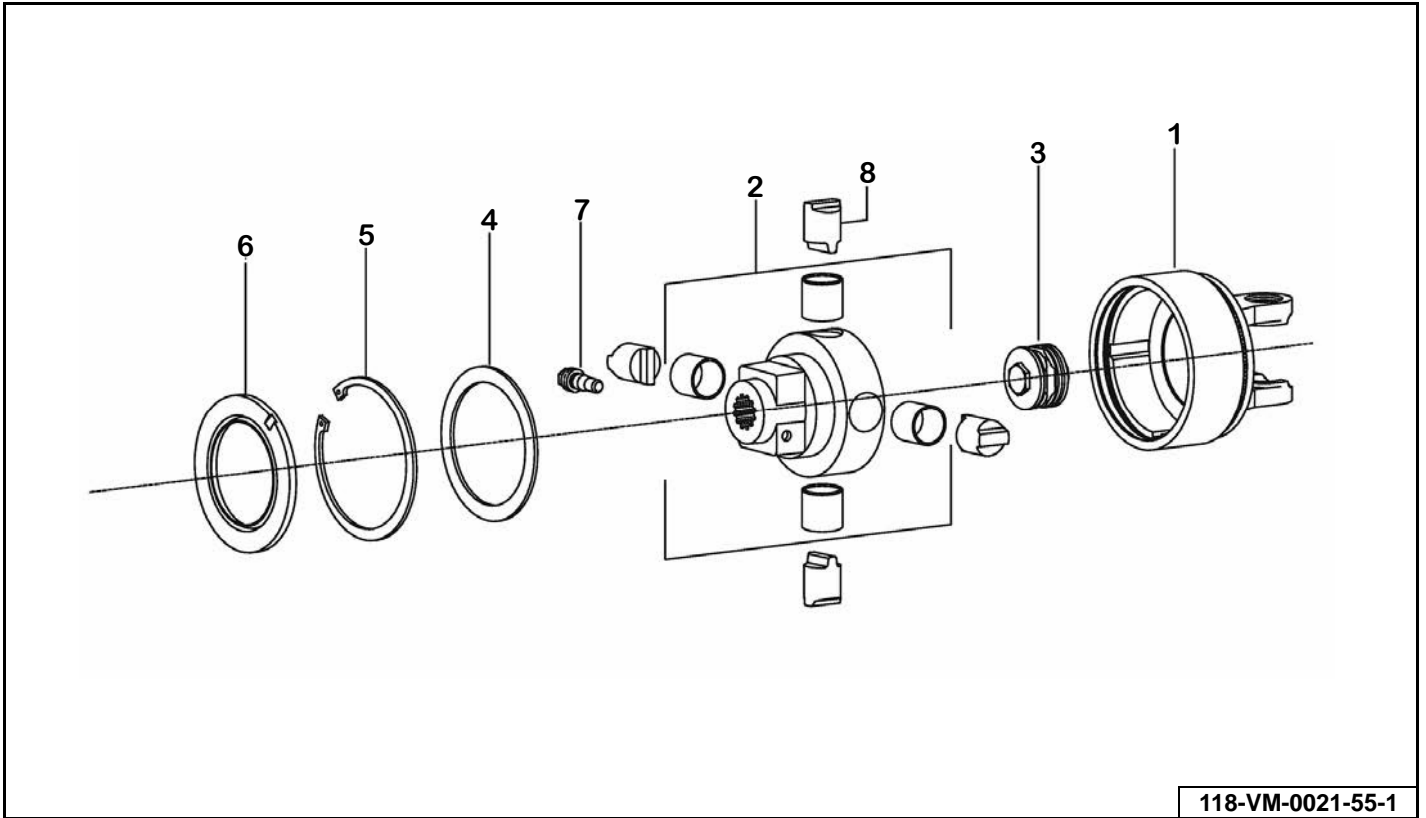

118-VM-0021-55-1

KEY	PART NUMBER	QTY	DESCRIPTION
0	118-2500-9	1	Cutout Clutch Complete
1	618-0202-2-3-1	1	Housing
2	118-VM-0021-55-1-1	1	Hub
3	118-2500-9-1	1	Spring Pack
4	918-0208-2-3-5	1	Washer
5	918-0208-2-3-6	1	Retaining Ring
6	918-0208-2-3-7	1	Sealing Ring
7	918-0410-2-1-1	1	Clamp Cone Assembly
8	918-0308-2-2-4	4	Cam

1-3/4-20 SPLINE X 1-3/4-20 SPLINE DRIVESHAFT

MODELS: 585 / F2-585 / 700 / F2-700

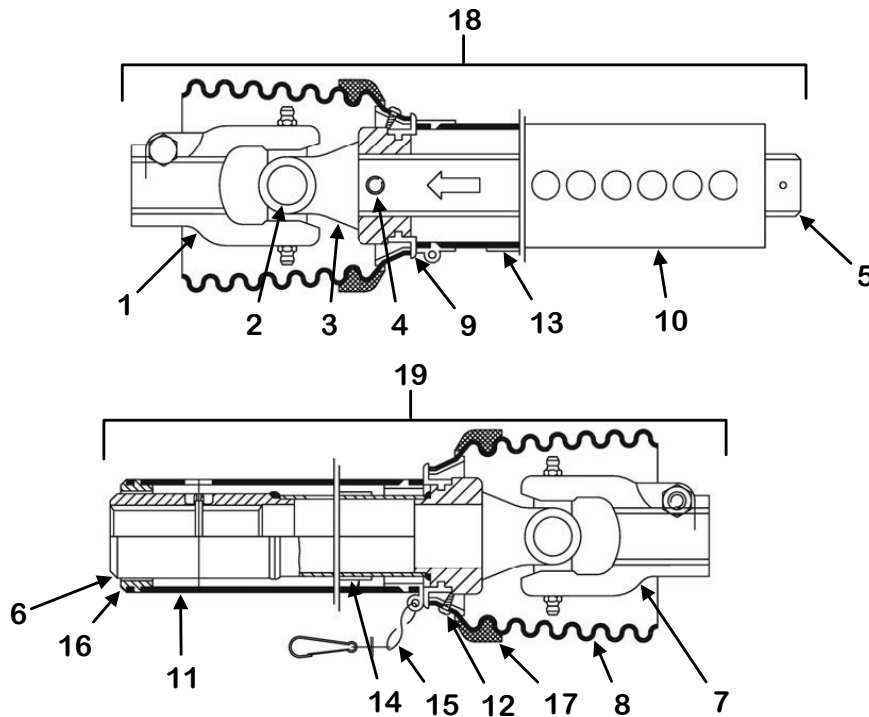

118-VM-0020-55

KEY	PART NUMBER	QTY	DESCRIPTION
0	118-VM-0020-55	1	1-3/4"-20 Spline PTO Complete
1	118-VM-0010-25-1	1	Yoke ASG
2	118-VM-0010-25-2	2	Cross & Bearing Kit
3	118-VM-0020-55-3	1	Inboard Yoke
4	618-0202-2-5	2	Spring Pin, 10 x 90
5	118-VM-0020-55-4	1	Inner Profile
6	118-VM-0020-55-5	1	Inboard Yoke (Includes Item 14)
7	118-VM-0010-25-1	1	Yoke AGKF
8	118-VM-0024-55-7	2	Guard Cone, 7 Rib (Includes Item 12)
9	918-0208-2-4	2	Bearing Ring
10	118-VM-0020-55-7	1	Guard Tube Outer (Includes Item 13)
11	118-VM-0020-55-8	1	Guard Tube Inner
12	918-0208-2-9	2	Screw
13	918-0208-2-8	1	Decal Outer
14	918-0208-1-10	1	Decal Inner
15	918-0208-2-7	1	Restraint Chain
16	918-0208-1-11	1	Support Bearing
17	618-0202-2-8	2	Reinforcing Collar
18	118-VM-0020-55-1	1	Male Half Shaft
19	118-VM-0020-55-2	1	Female Half Shaft

10.0 OPTIONAL PARTS

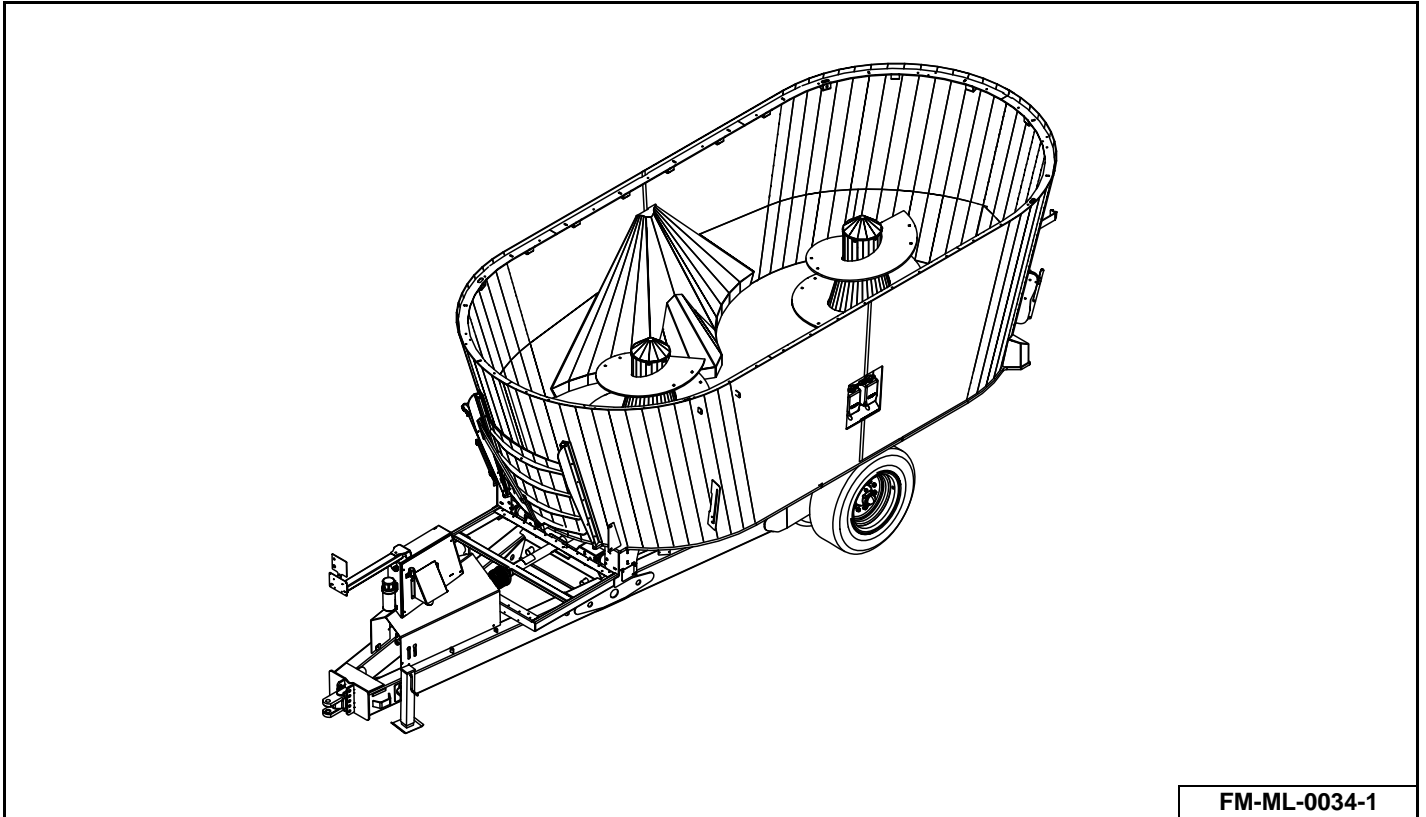

FM-ML-0034-1

KEY	DESCRIPTION	PAGE #
1	HAY RETAINING RING	206
2	8" CAPACITY EXTENSION	207
3	TIP OFF FRONT INCLINE DISCHARGE (CHAIN ONLY) & SIDE DISCHARGE	208
4	SIDE DISCHARGE SLIDE TRAY	209
5	SLIDE TRAY HYDRAULIC SCHEMATIC	210
6	KICKER MAGNET	211
7	REMOTE SCALE MOUNT	212
8	RUBBER SIDE DOOR CHUTE ASSEMBLY	214
9	CONVEYOR HANGING MAGNET & WEIGHT ASSEMBLY	216
10	CONVEYOR DEFLECTOR ASSEMBLY	216
11	POWER MAGNET	218

HAY RETAINING RING

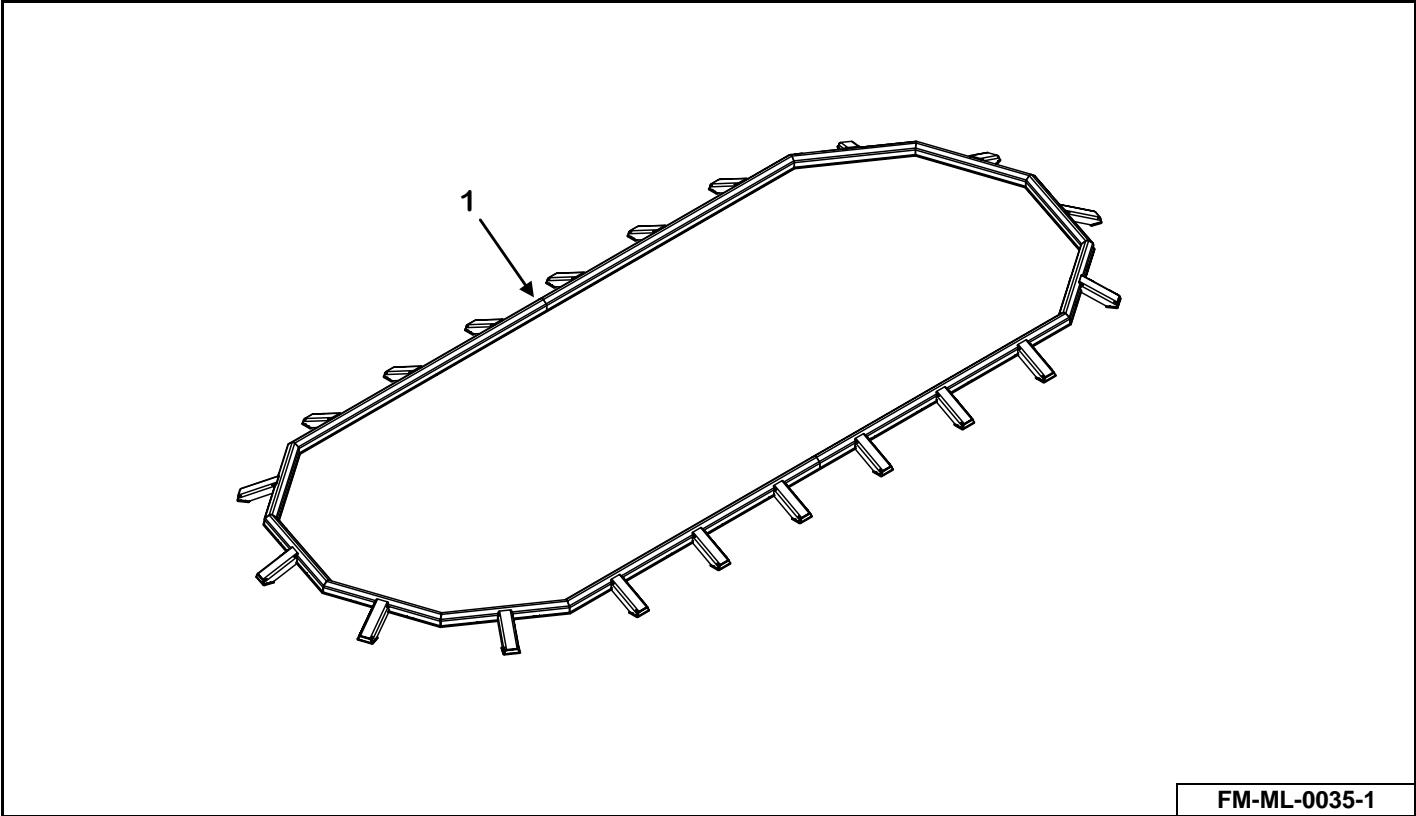

FM-ML-0035-1

KEY	PART NUMBER	QTY	DESCRIPTION	MIXER MODEL
1	M4-1-5-0002	1	Hay Retention Ring End Weldment	585/F2-585
	M4-1-7-0003	1	Hay Retention Ring End Weldment	700/F2-700
NS	851-5013-1.5Z	AR	1/2"-13 x 1 1/4" Bolt	All Models
NS	805-0050-Z	AR	1/2" Flat Washer	All Models
NS	810-5013-Z	AR	1/2" Spin Lock Nut	All Models

8" CAPACITY EXTENSION

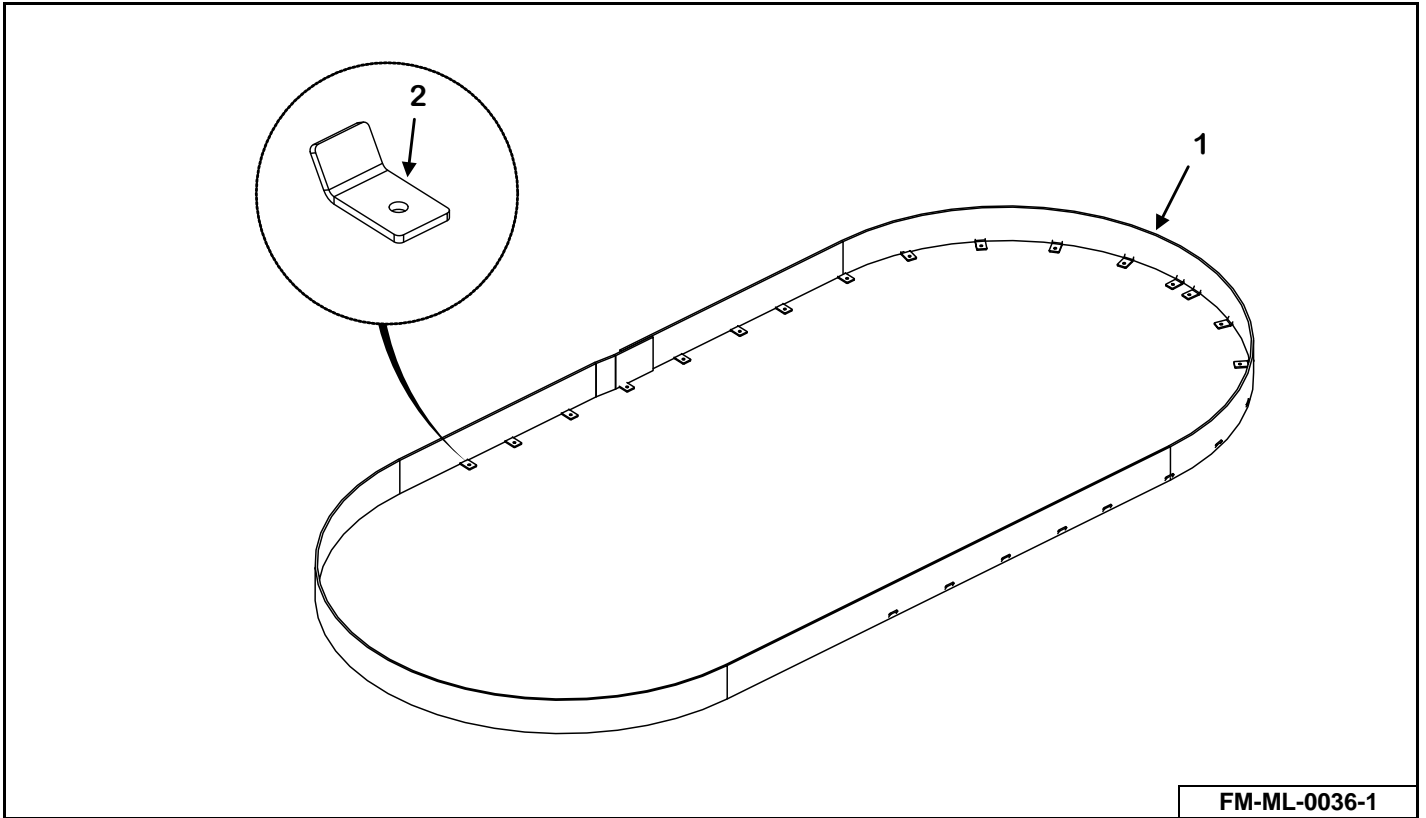

KEY	PART NUMBER	QTY	DESCRIPTION	MIXER MODEL
0	VA-0585-CE-8	1	8" Capacity Extension Assembly	585/F2-585
	VA-0700-CE-8	1	8" Capacity Extension Assembly	700/F2-700
1	M11-5-0001	1	8" Capacity Extension .453" x 8" x 45 FT	585/F2-585
	M11-7-0001	1	8" Capacity Extension .453" x 8" x 46 FT	700/F2-700
	805-0038-Z	4	3/8" Flat Washer	All Models
	815-3816-Z	2	3/8"-16 Nylon Insert Lock Nut	All Models
	851-3816-1.25Z	2	3/8"-16 x 1-1/4" Grade 5 Machine Bolt	All Models
2	M4-1-8-0006	38	Belt Extension Mounts	All Models
	805-0050-Z	38	1/2" Flat Washer	All Models
	814-5013-Z	38	1/2"-13 Indented Lock Nut	All Models
	851-5013-1.5Z	38	1/2"-13 x 1-1/2" Grade 5 Machine Bolt	All Models

TIP OFF FRONT INCLINE DISCHARGE (CHAIN ONLY) & SIDE DISCHARGE

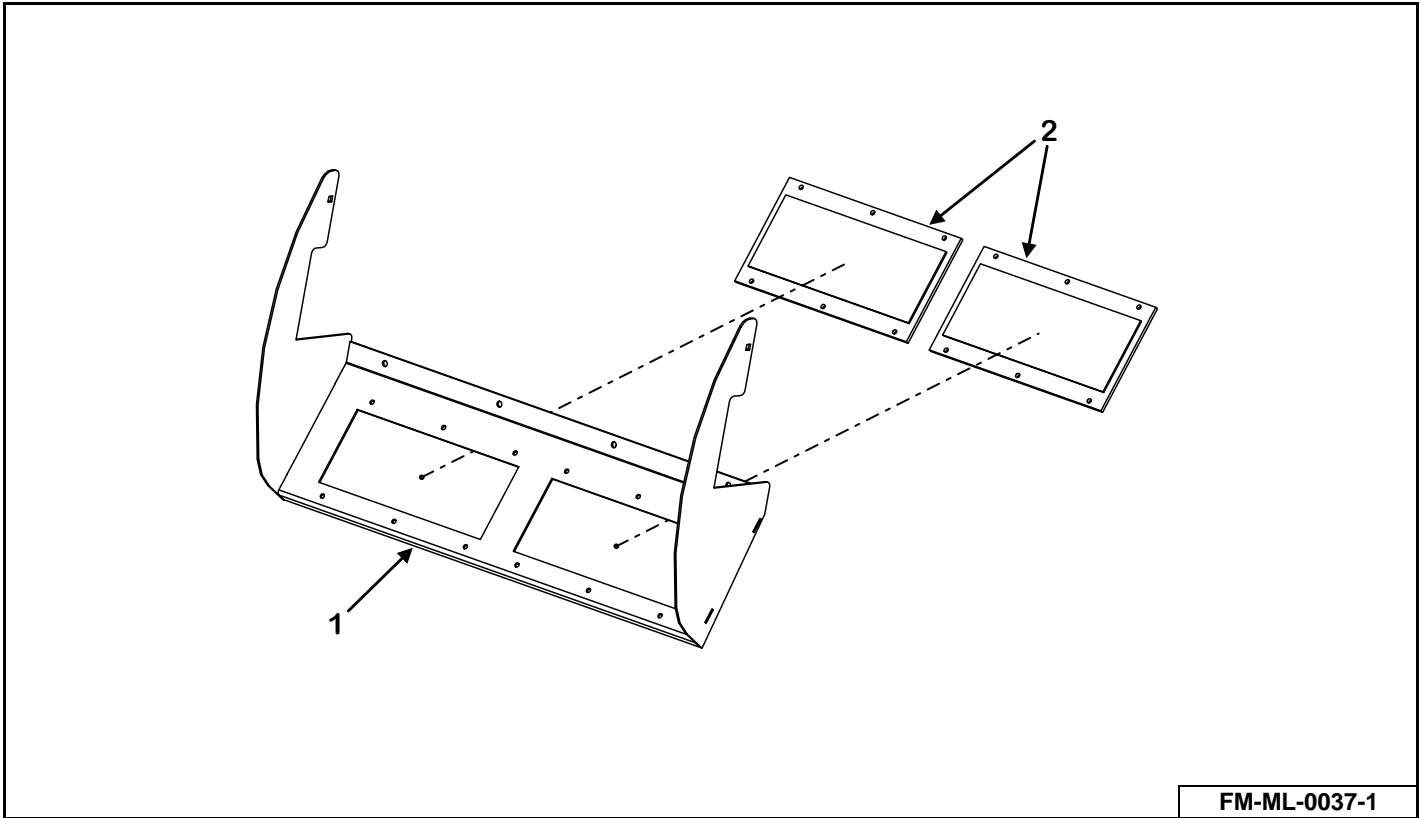

KEY	PART NUMBER	QTY	DESCRIPTION	MIXER MODEL
1	M3-1-7-0015	1	Front Incline Discharge Tip Off Weldment	All Front Models
	M3-1-12-0005	1	Side Discharge Conveyor Tip Off Weldment	All Side Models
	810-3816-Z	8	3/8" Spin Lock Nut	All Models
	851-3816-.75Z	6	3/8-16 x 3/4" Bolt	All Models
	850-3816-.75Z	2	3/8-16 x 3/4" Bolt	All Models
2	M11-1-0004	2	15" Discharge Magnet	All Front Models
	M11-1-0009	2	18.5" Discharge Magnet	All Side Models
	802T-3118-.75Z	12	5/16-18 x 3/4" Truss Head Machine Screw	All Front Models
	802T-3118-.75Z	16	5/16-18 x 3/4" Truss Head Machine Screw	All Side Models
	810-3118-Z	12	5/16-18 Spin Lock Nut	All Front Models
	810-3118-Z	16	5/16-18 Spin Lock Nut	All Side Models

SIDE DISCHARGE SLIDE TRAY

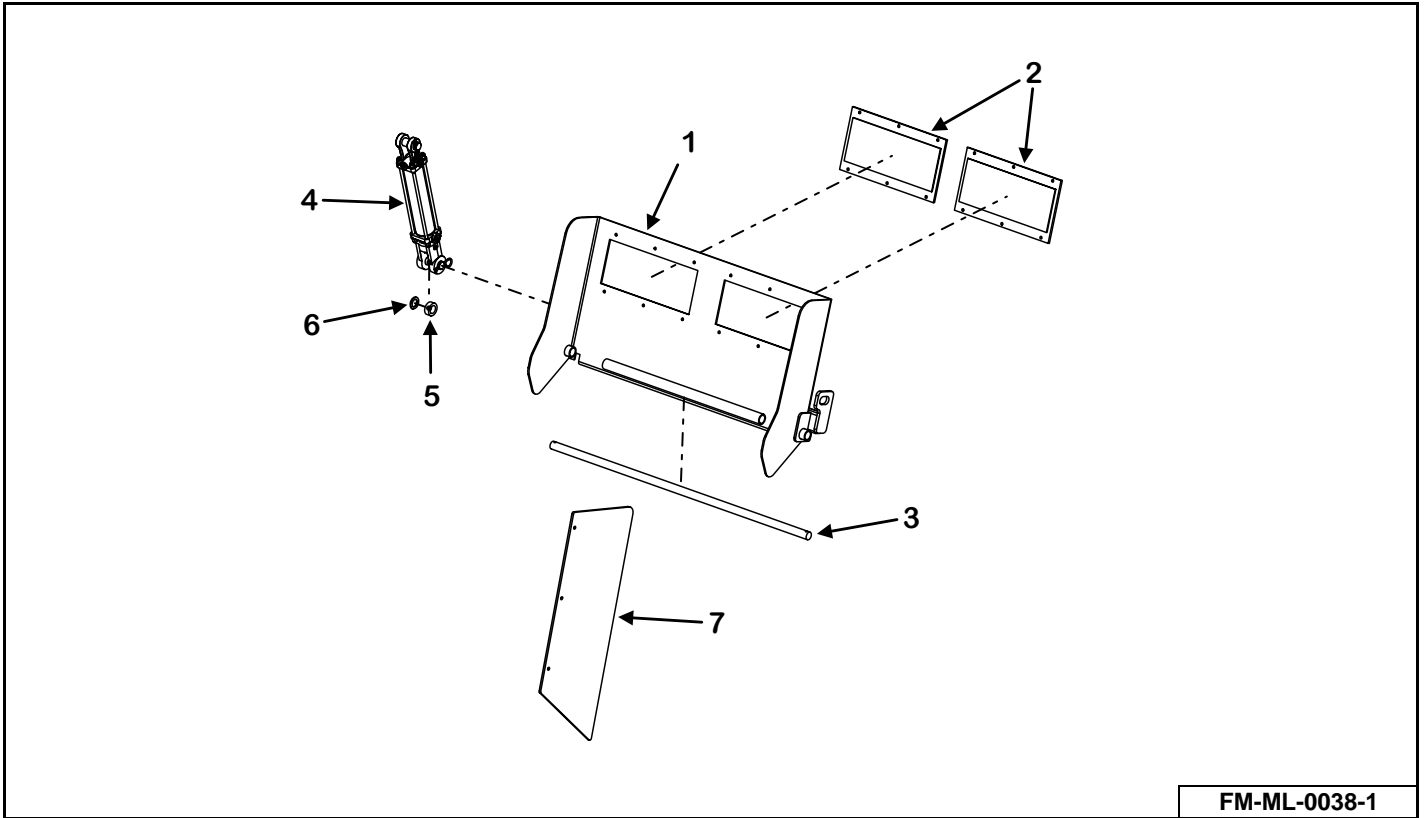

FM-ML-0038-1

KEY	PART NUMBER	QTY	DESCRIPTION	MIXER MODEL
1	M3-1-12-0006	1	42" Slide Tray Weldment With Magnet Cutouts	All Models
	M3-1-12-0022-1	1	42" Slide Tray Weldment Without Magnet Cutouts	All Models
	M3-1-12-0022	1	42" Slide Tray Weldment Without Magnet Cutouts (Includes Item 3)	All Models
2	M11-1-0009	2	18-1/2" Discharge Magnet	All Models
	802T-3118-.75Z	16	5/16"-18 x 3/4" Screw	All Models
	810-3118-Z	16	5/16"-18 Spin Lock Nut	All Models
3	M3-1-12-0008	1	Chute Pivot Rod 1" x 47-3/4"	All Models
4	155-2-8-1.125-1	1	2" x 8" x 1-1/8" Hydraulic Cylinder #8 SAE Ports	All Models
5	33-0309	1	Cylinder Pin Spacer	All Models
6	808-1-1.5-10-Z	1	10GA 1" ID x 1-1/2" OD MB	All Models
7	M3-1-4-0044	1	Slide Tray Deflector Belting	All Models
	805-0038-Z	3	3/8" Flat Washer	All Models
	815-3816-Z	3	3/8"-16 Nylon Insert Lock Nut	All Models
	850-3816-1Z	3	3/8"-16 x 1" Bolt	All Models

SLIDE TRAY HYDRAULIC SCHEMATIC

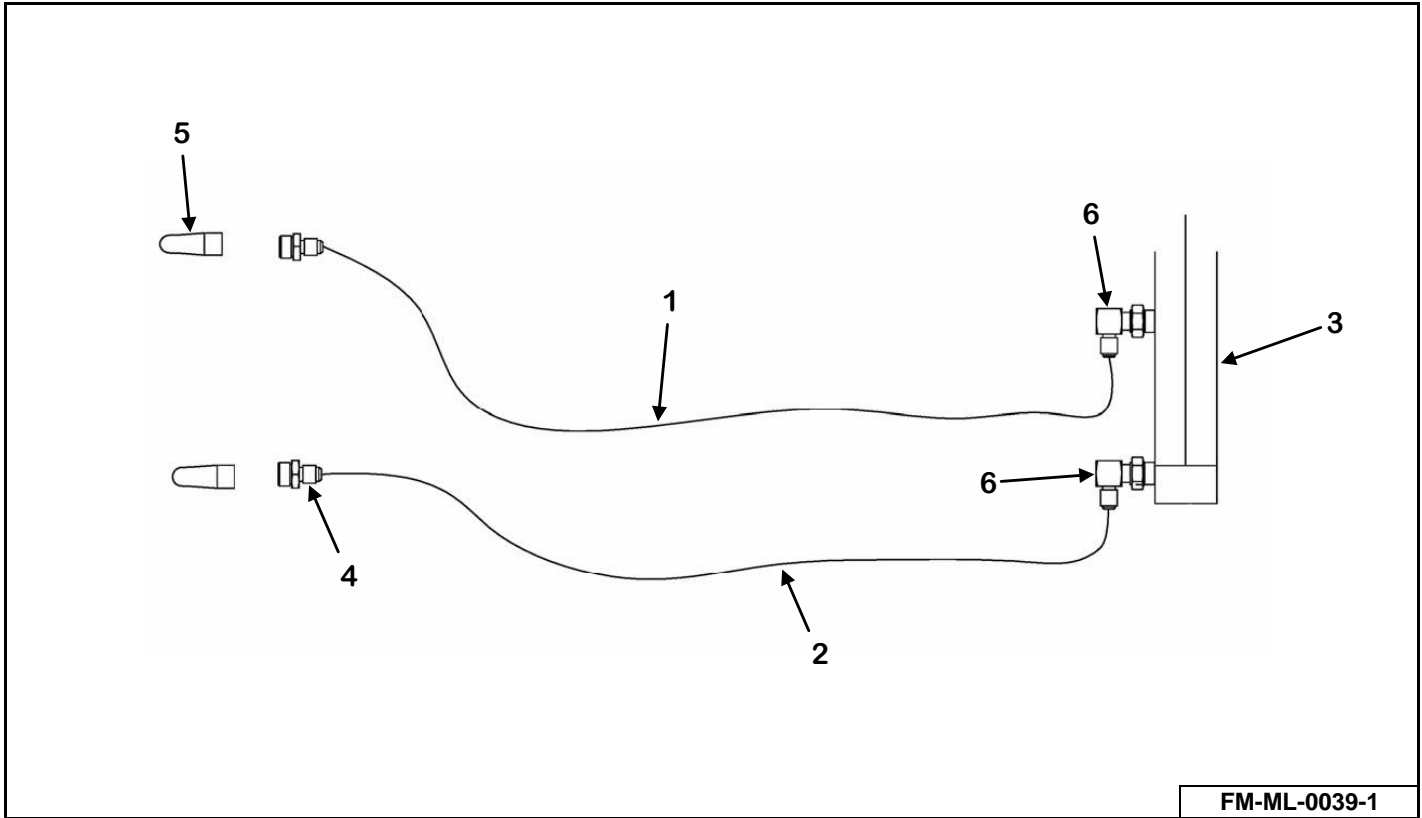

FM-ML-0039-1

KEY	PART NUMBER	QTY	DESCRIPTION	MIXER MODEL
1	155-04R17-240-1	1	1/4" x 240" Hose Assembly	585/700
	155-04R17-262-1	1	1/4" x 262" Hose Assembly	F2-585/F2-700
2	155-04R17-233-1	1	1/4" x 233" Hose Assembly	585/700
	155-04R17-275-1	1	1/4" x 275" Hose Assembly	F2-585/F2-700
3	155-2-8-1.125-1	1	2" x 8" x 1-1/8" Hydraulic Cylinder	All Models
4	155-6400-6-8	2	#6 JIC Male, #8 ORB Male Straight Connector	All Models
5	155-8010-15	2	#8 ORB Male Tip 1/2" Body Size	All Models
6	155-6801-6-8	1	#6 JIC Male, #8 ORB Male Adjustable 90°	All Models

KICKER MAGNET

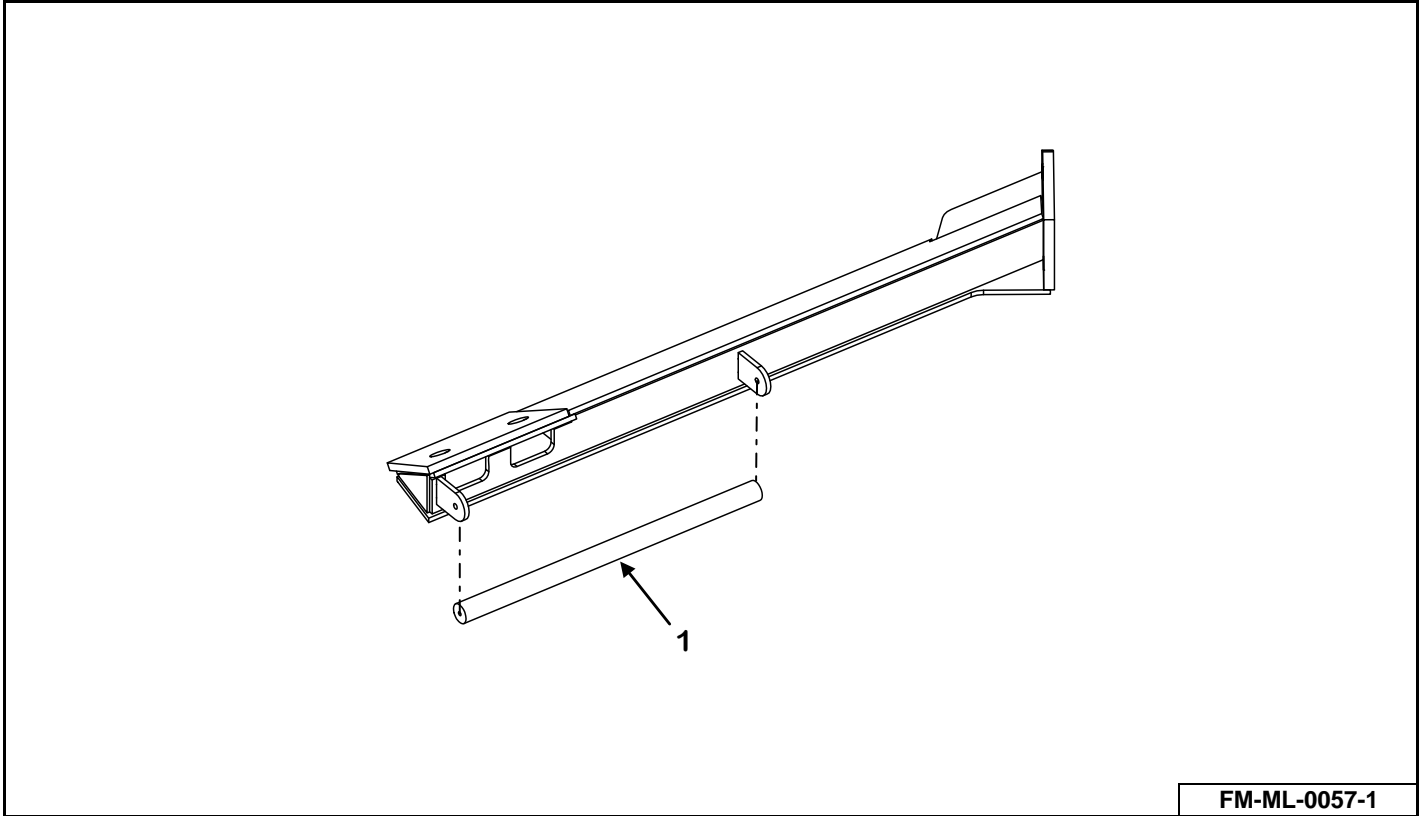

FM-ML-0057-1

KEY	PART NUMBER	QTY	DESCRIPTION	MIXER MODEL
0	VAM-AKM-K	2	Kicker Weldment With Magnet Kit	All Models
1	VAM-AKM-K	2	Kicker Weldment With Magnet Kit (Prior to 2021 Model Year)	585/700
	M3-1-8-0020-4	AR	Kicker Magnet (2021 Model Year & Later)	All Models
	851-2520-.75Z	2 per	1/4"-20 x 3/4" Hex Cap Screw	All Models
	822-0025-Z	2 per	1/4" Split Lock Washer	All Models

REMOTE SCALE MOUNT

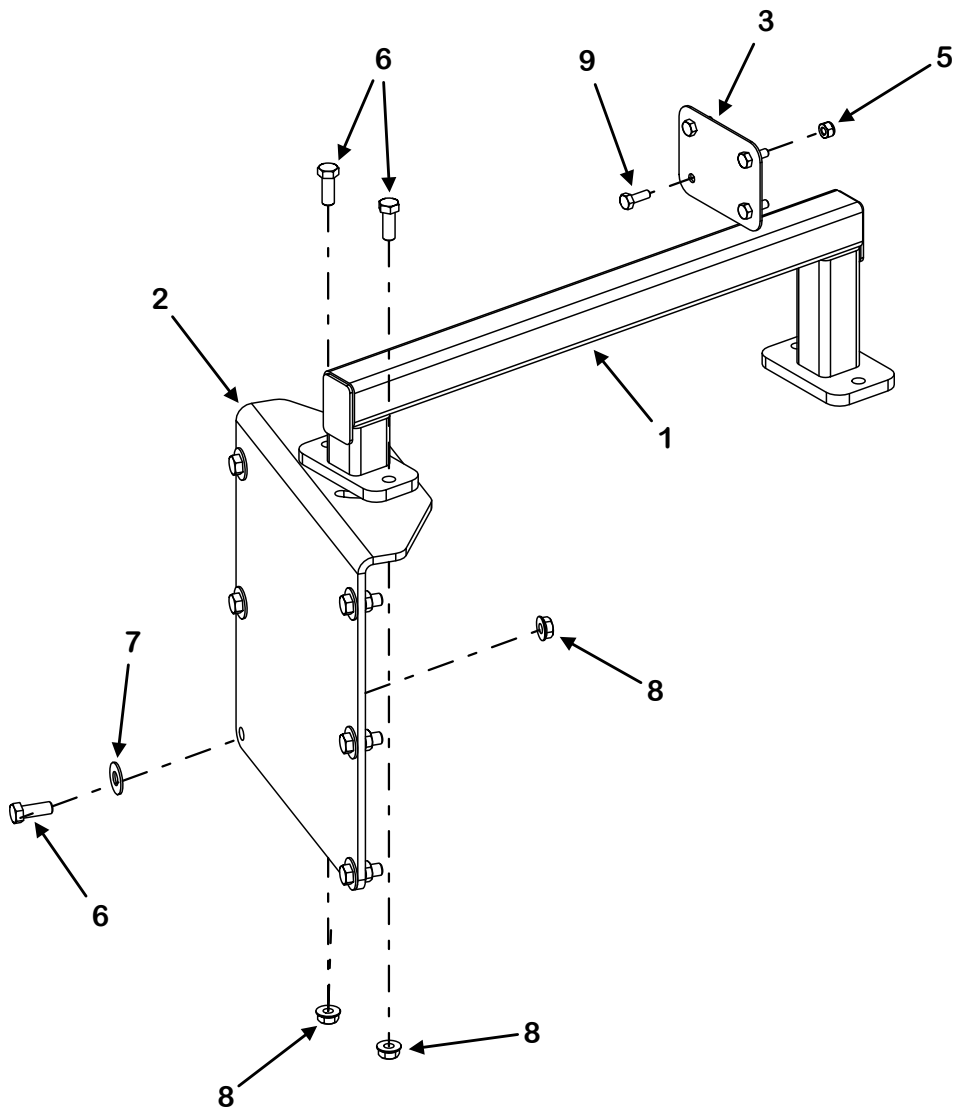

FM-ML-0043-1

KEY	PART NUMBER	QTY	DESCRIPTION	MIXER MODEL
0	VMSCM-405180	1	Remote Display Kit RD400 With TR Kit & 33' Cable/Visor	All Models
	VMSCM-405200	1	Remote Display Kit RD400 With 33' Cable/Visor	All Models
	VMSCM-407227	1	Remote Display Kit RD250 With 25' Cable	All Models
1	M9-1-10-0001	1	Remote Scale Mount Bracket Weldment	All Models
2	M9-1-10-0002	1	Remote Scale Mount Bracket	All Models
3	M9-1-10-0003	1	Remote Scale Mount Belt Gusset	All Models
4	58-0010-405180	1	RD4000 Remote Display Kit W/TR-33' Cable/Visor	All Models
	58-0010-405200	1	RD4000 Remote Display Kit W/33' Cable/Visor	All Models
5	815-2520-Z	4	1/4"-20 Nylon Insert Lock Nut	All Models
6	851-3816-1Z	8	3/8"-16 x 1" Grade 5 Machine Bolt	All Models
7	805-0038-Z	6	3/8" Flat Washer	All Models
8	810-3816-Z	8	3/8" Spin Lock Nut	All Models
9	851-2520-.75Z	4	1/4"-20 x 3/4" Grade 5 Machine Bolt	All Models
NS	58-0010-1	1	Remote Cable, Y-Harness For Dual Remote	All Models (Optional)

RUBBER SIDE DOOR CHUTE ASSEMBLY

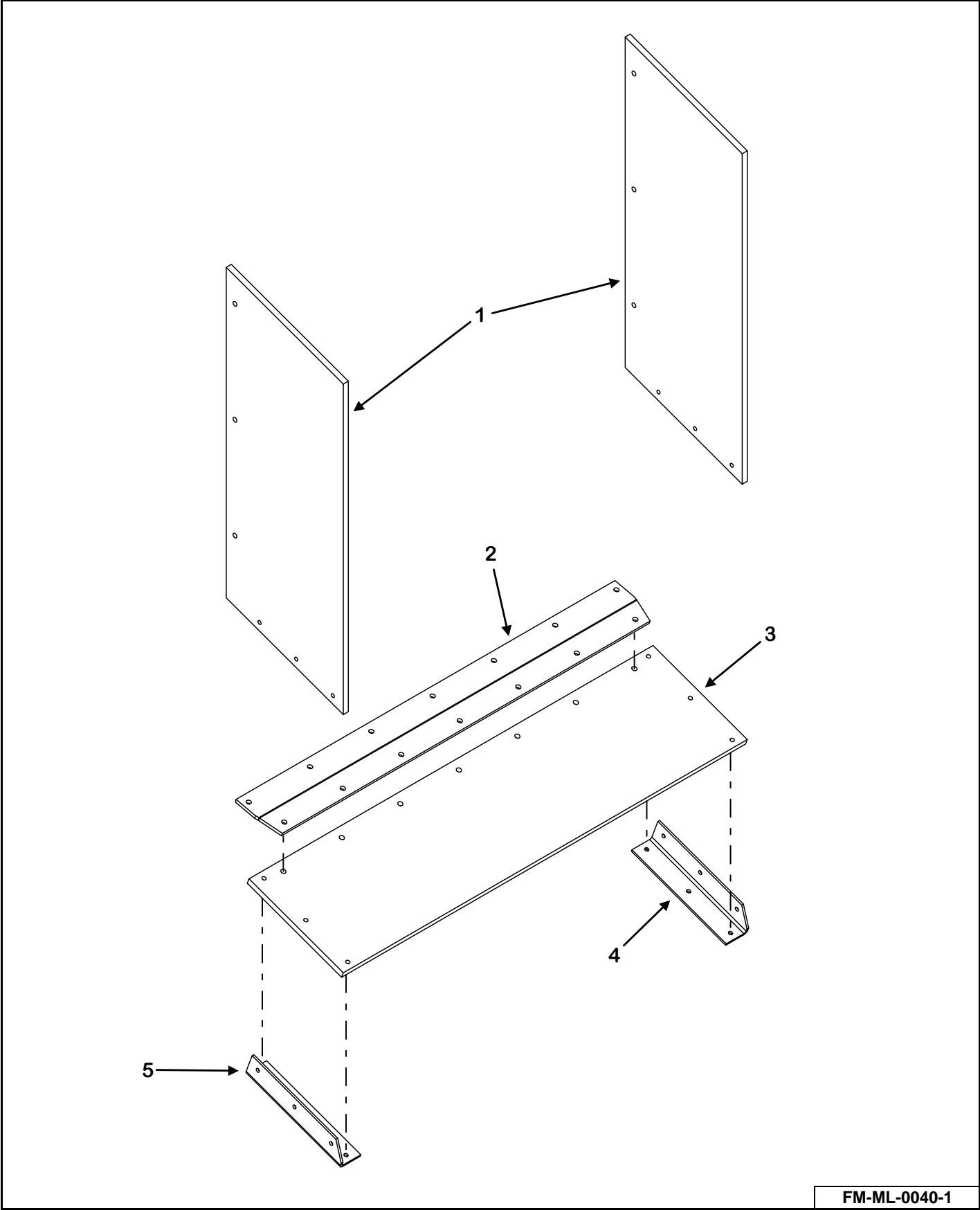

FM-ML-0040-1

KEY	PART NUMBER	QTY	DESCRIPTION	MIXER MODEL
0	VAML-SDBC-12	1	12" Side Door Belt Chute	All Models
	VAML-SDBC-18	1	18" Side Door Belt Chute	All Models
1	M11-5-0002-2	2	Chute Side Belt (12" Belt Chute)	All Models
	M11-5-0002-2-18	2	Chute Side Belt (18" Belt Chute)	All Models
2	M11-5-0002-5	1	Side Door Belt Chute Mount	All Models
3	M11-5-0002-1	1	Chute Bottom Belt (12" Belt Chute)	All Models
	M11-5-0002-1-18	1	Chute Bottom Belt (18" Belt Chute)	All Models
4	M11-5-0002-4	1	Chute Corner Right Side Bracket (Facing Door) (12" Belt Chute)	All Models
	M11-5-0002-4-18	1	Chute Corner Right Side Bracket (Facing Door) (18" Belt Chute)	All Models
5	M11-5-0002-3	1	Chute Corner Left Side Bracket (Facing Door) (12" Belt Chute)	All Models
	M11-5-0002-3-18	1	Chute Corner Right Side Bracket (Facing Door) (18" Belt Chute)	All Models
NS	802T-2520-1Z	12	1/4"-20 x 1" Truss Head Machine Screw (12" Belt Chute)	All Models
	802T-2520-1Z	20	1/4"-20 x 1" Truss Head Machine Screw (18" Belt Chute)	All Models
NS	802T-3118-1.25Z	20	5/16"-18 x 1-1/4" Truss Head Machine Screw	All Models
NS	805-0025-Z	12	1/4" Flat Washer (12" Belt Chute)	All Models
	805-0025-Z	20	1/4" Flat Washer (18" Belt Chute)	All Models
NS	805-0031-Z	13	5/16" Flat Washer	All Models
NS	810-3118-Z	7	5/16"-18 Spin Lock Nut	All Models
NS	815-2520-Z	12	1/4"-20 Nylon Insert Lock Nut (12" Belt Chute)	All Models
	815-2520-Z	20	1/4"-20 Nylon Insert Lock Nut (18" Belt Chute)	All Models
NS	815-3118-Z	13	5/16"-18 Nylon Insert Lock Nut	All Models

CONVEYOR HANGING MAGNET & WEIGHT ASSEMBLY

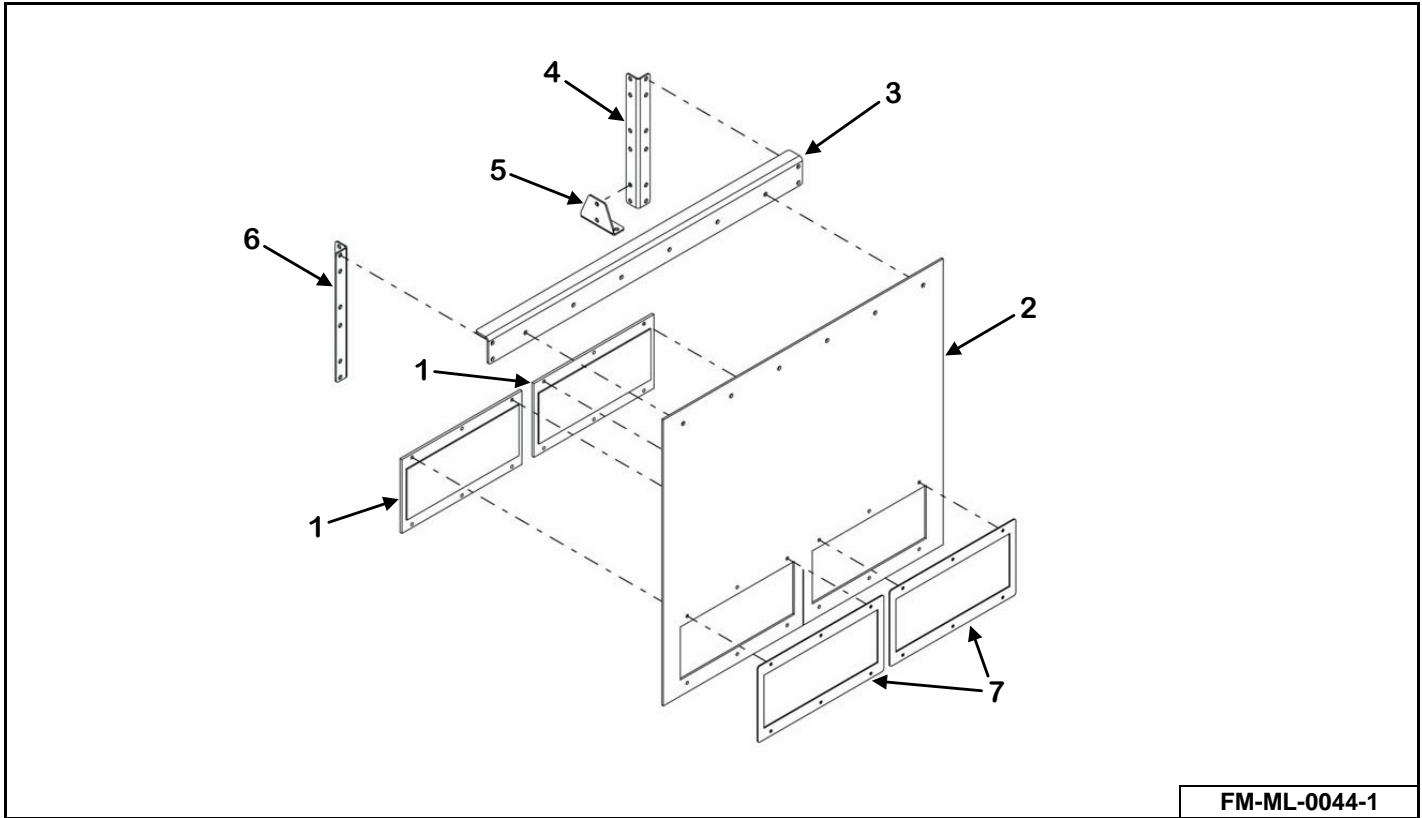

CONVEYOR DEFLECTOR ASSEMBLY

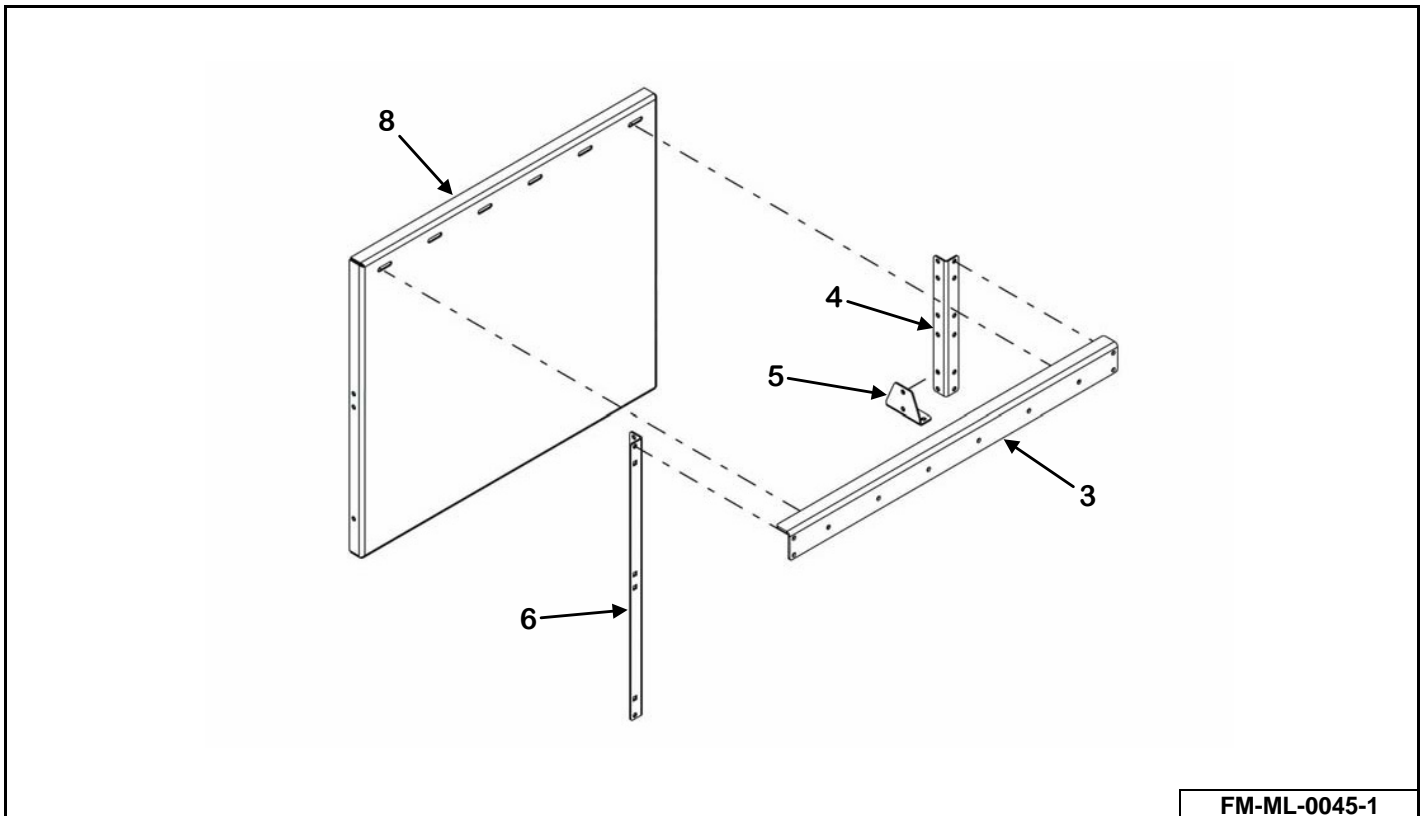

KEY	PART NUMBER	QTY	DESCRIPTION	MIXER MODEL
0	VAML-HMB-F	1	Hanging Magnet Kit For Left / Right Discharge (Front Flat Belt Conveyor)	All Models
	VAML-HMB-I	1	Hanging Magnet Kit For Left / Right Discharge (Front Incline Belt Conveyor)	All Models
	VAML-HDB-F	1	Hanging Weight Kit For Left/Right Discharge (Front Flat Belt Conveyor)	All Models
	VAML-HDB-I	1	Hanging Weight Kit For Left/Right Discharge (Front Incline Belt Conveyor)	All Models
	VAML-DBD-F	1	Deflector Kit For Left/Right Discharge (Front Flat Belt Conveyor)	All Models
	VAML-DBD-I	1	Deflector Kit For Left/Right Discharge (Front Incline Belt Conveyor)	All Models
	VAML-HMC	1	Hanging Magnet Kit For Left/Right Discharge (Front Flat Chain Conveyor)	All Models
1	M11-1-0004	2	15" Hanging Magnet	All Models
	M11-1-0026	2	15" Hanging Weight Plate	All Models
2	M11-1-0003-4	1	Magnet Belting	All Models
3	M11-1-0003-1	1	Hanging Magnet Mount (Front Flat Belt Conveyor)	All Models
	M11-7-0003	1	Hanging Magnet Mount (Front Flat Chain Conveyor)	All Models
4	M11-1-0003-2	1	Magnet Mount Rear Support Upright (Front Flat Belt Conveyor)	All Models
	M11-7-0002	1	Magnet Mount Rear Support Upright (Front Incline Belt Conveyor)	All Models
	M11-7-0004	1	Magnet Mount Rear Support Upright (Front Flat Chain Conveyor)	All Models
5	M11-1-0003-3	1	Magnet Support Mount	All Models
6	M11-1-0003-2	1	Magnet Mount Front Support Upright (Front Flat Belt Conveyor) Prior to SN 17VM(0585201, 0700205, 0815202, 1015205, 1215204)	All Models
	M11-7-0002	1	Magnet Mount Front Support Upright (Front Flat & Incline Belt Conveyor) SN 17VM(0585201, 0700205, 0815202, 1015205, 1215204) & Later	All Models
	M11-7-0002	1	Magnet Mount Front Support Upright (Front Flat Chain Conveyor)	All Models
7	M11-1-0003-4-1	2	Hanging Magnet/Weight Backer Plates	All Models
8	M11-1-0003-5	1	Deflector Plate (Belt Conveyor Only)	All Models

POWER MAGNET

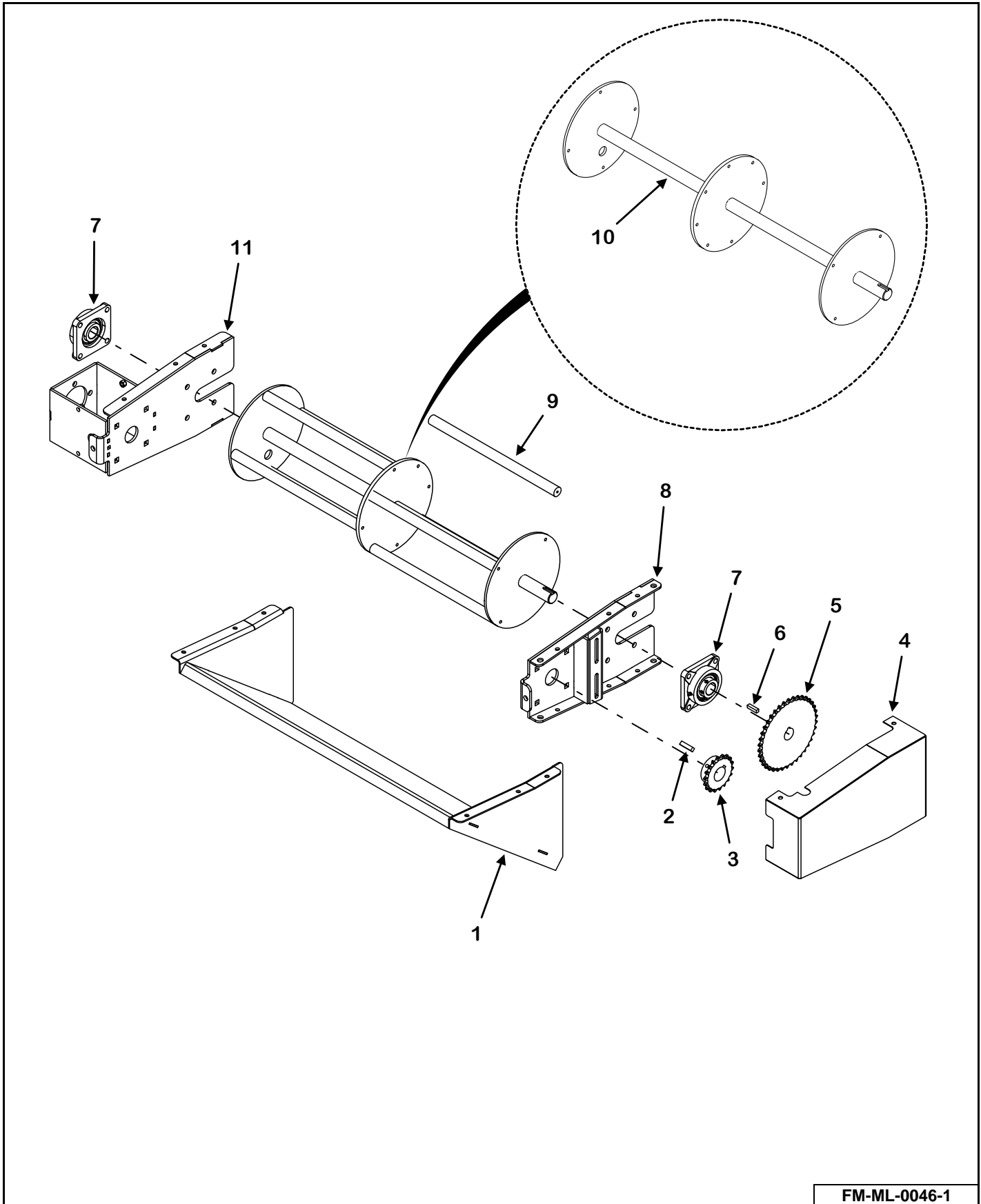

FM-ML-0046-1

KEY	PART NUMBER	QTY	DESCRIPTION	MIXER MODEL
0	VAML-PRM-FDI- KIT	1	Medium/Large Family Power Magnet Flat Conveyor Kit	All Models
1	M3-1-10-0028	1	Deflector Weldment	All Models
2	35-0010	1	3/8" x 3/8" x 1-1/2" Square Key	All Models
3	110-50B18-1.5-1	1	50B18 1-1/2" Sprocket	All Models
4	M3-1-10-0029-1	1	Shield Weldment	All Models
5	110-50B38-1.25-1	1	50B38 1-1/4" Sprocket	All Models
6	35-0030-H	1	5/16" x 5/16" x 1-1/4" Square Key	All Models
7	14-0101	2	1-1/4" 4-Bolt Bearing	All Models
8	M3-1-10-0025	1	Bearing Mount Weldment	All Models
9	M3-1-8-0020-4	8	Magnet Tube	All Models
10	M3-1-8-0020-1	1	Spinner Weldment	All Models
11	M3-1-10-0026	1	Motor Mount Weldment	All Models



11.0 SPECIFICATIONS

585 / 700 DIMENSIONS		
	585	700
Overall Length - Side Door / Front Door	215" / 245"	273" / 288"
Mixing Chamber Length	212"	217"
Overall Height - Tire Option Used	245/70-19.5	245/70-19.5
Overall Height - Base Machine	97"	107"
Overall Height - Belt Extensions	103"	113"
Overall Height - Hay Retention Ring	103"	113"
Tread Width	87"	87"
Transport Width - Front Conveyor / Side Conveyor - W/36" Ext.	99" / 113"	101" / 115"
Max Discharge Reach - Front Cross Conveyor - Flat	9"	9"
Max Discharge Reach - Front Cross Conveyor - Incline 24" / 36" / 48" (In Down Position)	23" / 34" / 45"	23" / 34" / 45"
Max Discharge Reach - Side Conveyor - 24" / 36" / 48" / 60" / 72" (In Down Position)	35" / 46" / 57" / 68" / 79"	35" / 46" / 57" / 68" / 79"
Max Discharge Reach - Side Slide Tray	21"	21"
Max Discharge Reach - Side Belt Extension	16"	16"
Max Discharge Height - Front Cross Conveyor - Flat	32"	32"
Max Discharge Height - Front Cross Conveyor - Incline 24" / 36" / 48" (In Down Position)	34" / 37" / 40"	34" / 37" / 40"
Max Discharge Height - Side Conveyor - 24" / 36" / 48" / 60" / 72" (In Down Position)	32" / 36" / 40" / 44" / 48"	32" / 36" / 40" / 44" / 48"
Max Discharge Height - Side Slide Tray	15"	15"
Max Discharge Height - Side Belt Extension	24"	24"

F2-585 / F2-700 DIMENSIONS		
	F2-585	F2-700
Overall Length - Side Door / Front Door		
Mixing Chamber Length		
Overall Height - Tire Option Used		
Overall Height - Base Machine		
Overall Height - Belt Extensions		
Overall Height - Hay Retention Ring		
Tread Width		
Transport Width - Front Conveyor / Side Conveyor - W/ 36" Ext.		
Max Discharge Reach - Front Cross Conveyor - Flat		
Max Discharge Reach - Front Cross Conveyor - Incline 24" / 36" / 48" (In Down Position)		
Max Discharge Reach - Side Conveyor - 24" / 36" / 48" / 60" / 72" (In Down Position)		
Max Discharge Reach - Side Slide Tray		
Max Discharge Reach - Side Belt Extension		
Max Discharge Height - Front Cross Conveyor - Flat		
Max Discharge Height - Front Cross Conveyor - Incline 24" / 36" / 48" (In Down Position)		
Max Discharge Height - Side Conveyor - 24" / 36" / 48" / 60" / 72" (In Down Position)		
Max Discharge Height - Side Slide Tray		
Max Discharge Height - Side Belt Extension		

585 / 700 SPECIFICATIONS		
	585	700
Mixing Capacity - No Extension	585 Cu. Ft.	693 Cu. Ft.
Mixing Capacity - Extensions	647 Cu. Ft.	760 Cu. Ft.
Unit Weight - Front Discharge - lbs (Option Sensitive)	N/A	~14,660
Unit Weight - Side Discharge - lbs (Option Sensitive)	~13,080	N/A
Maximum Net Load - lbs	19,410	22,800
Auger Qty.	2	2
Auger Diameter	88"	88"
Auger Speed - Standard / High Speed	27 / 40 RPM	27 / 40 RPM
Auger - Upper Flighting Thickness	5/8"	5/8"
Auger - Lower Flighting Thickness	5/8"	5/8"
Auger - Knives - Adjustable - Per Auger	5	6
Planetary Drive	Straight-Drive	Straight-Drive
PTO Drive	1000 RPM	1000 RPM
Drive Protection	Torque-Disconnect	Torque-Disconnect
Discharge Door Opening - Front	42" x 40"	42" x 40"
Discharge Door Opening - Side	42" x 40"	42" x 40"
Discharge Door Opening - Rear	42" x 40"	42" x 40"
Discharge - Conveyor Width - Front / Side	36" x 42"	36" x 42"
Discharge - Front Cross Conveyor Travel - Left or Right	8"	8"
Tub / Trailer - Floor Thickness	5/8"	5/8"
Tub / Trailer - Sidewall Thickness	1/4"	1/4"
Tub / Trailer - Trailer or Subframe	Single-Axle	Single-Axle
Tub / Trailer - Spindle Diameter	2-3/4"	2-3/4"
Tub / Trailer - Scale System	4-Point	4-Point
Tongue Weight - % Gross	10%	10%
Tractor Requirement - PTO HP	110	110

F2-585 / F2-700 SPECIFICATIONS		
	F2-585	F2-700
Mixing Capacity - No Extension		
Mixing Capacity - Extensions		
Unit Weight - Front Discharge - lbs (Option Sensitive)	N/A	~14,940
Unit Weight - Side Discharge - lbs (Option Sensitive)	~13,540	N/A
Maximum Net Load - lbs	19,410	22,800
Auger Qty.		
Auger Diameter		
Auger Speed - Standard / High Speed		
Auger - Upper Flighting Thickness		
Auger - Lower Flighting Thickness		
Auger - Knives - Adjustable - Per Auger		
Planetary Drive		
PTO Drive		
Drive Protection		
Discharge Door Opening - Front		
Discharge Door Opening - Side		
Discharge Door Opening - Rear		
Discharge - Conveyor Width - Front / Side		
Discharge - Front Cross Conveyor Travel - Left or Right		
Tub / Trailer - Floor Thickness		
Tub / Trailer - Sidewall Thickness		
Tub / Trailer - Trailer or Subframe		
Tub / Trailer - Spindle Diameter		
Tub / Trailer - Scale System		
Tongue Weight - % Gross		
Tractor Requirement - PTO HP		

FEATURES				
	585	700	F2-585	F2-700
Twin Mixing Augers	STD	STD	STD	STD
Replaceable Scrapers	STD	STD	STD	STD
Hardened Knives	STD	STD	STD	STD
Hay Stops	STD	STD	STD	STD
Ladder	STD	STD	STD	STD
Jack Stand	STD	STD	STD	STD
Torque Disconnect PTO's	STD	STD	STD	STD
Stop & Shift Gearbox (Electric Shift)	STD	STD	STD	STD
Power Shift Transmission (Electric Shift)	STD	STD	STD	STD
Straight Drive	N/A	N/A	STD	STD
Heavy-Duty Gearboxes	STD	STD	STD	STD
Single Axle Trailer	STD	STD	STD	STD

OPTIONS				
	585	700	F2-585	F2-700
Tandem Axle Trailer	OPT	OPT	OPT	OPT
Side Discharge Door Right/Left	OPT	OPT	OPT	OPT
Front Discharge Door	OPT	OPT	OPT	OPT
Rear Discharge Door	OPT	OPT	OPT	OPT
Front Cross Conveyor	OPT	OPT	OPT	OPT
Side Door Conveyor	OPT	OPT	OPT	OPT
Viewing Platform	OPT	OPT	OPT	OPT
Slide Tray	OPT	OPT	OPT	OPT
Safety Chain	OPT	OPT	OPT	OPT
Magnets	OPT	OPT	OPT	OPT
Hay-Retention Ring	OPT	OPT	OPT	OPT
Capacity Belt Extension	OPT	OPT	OPT	OPT
Hardened Knives (Additional)	OPT	OPT	OPT	OPT
Tank Liner	OPT	OPT	OPT	OPT
Baffle Liner	OPT	OPT	OPT	OPT



**Manufactured by:
Meyer Manufacturing
Corporation**

674 W. Business Cty Rd A

Dorchester, WI 54425

Phone. 1-800-325-9103

Fax: 715-654-5513

Email: parts@meyermfg.com

Website: www.meyermfg.com