

585/700 STOP-SHIFT TRUCK MOUNT SPECIFICATIONS



FORMULA III

Truck Specification Questions?

Contact the Meyer Service Department
 (800) 325-9103
 sales@meyermfg.com

MIXER MODEL	AXLE TYPE	MINIMUM GVWR	MINIMUM FRAME SECTION MODULUS*	MINIMUM FRONT/REAR	MINIMUM ENGINE HP	MINIMUM ENGINE DISPLACEMENT	MINIMUM TORQUE @ PTO ADAPTER**
F585-M SIDE DOOR	SINGLE	45,000#	17	12,000# / 33,000#	300 HP	8 LITER	500 FT-LBS @ 100% PTO
F585-M SIDE DOOR	TANDEM	52,000#	17	12,000# / 40,000#	300 HP	8 LITER	500 FT-LBS @ 100% PTO
F700-M SIDE DOOR	TANDEM	54,000#	17	14,000# / 40,000#	300 HP	8 LITER	500 FT-LBS @ 100% PTO

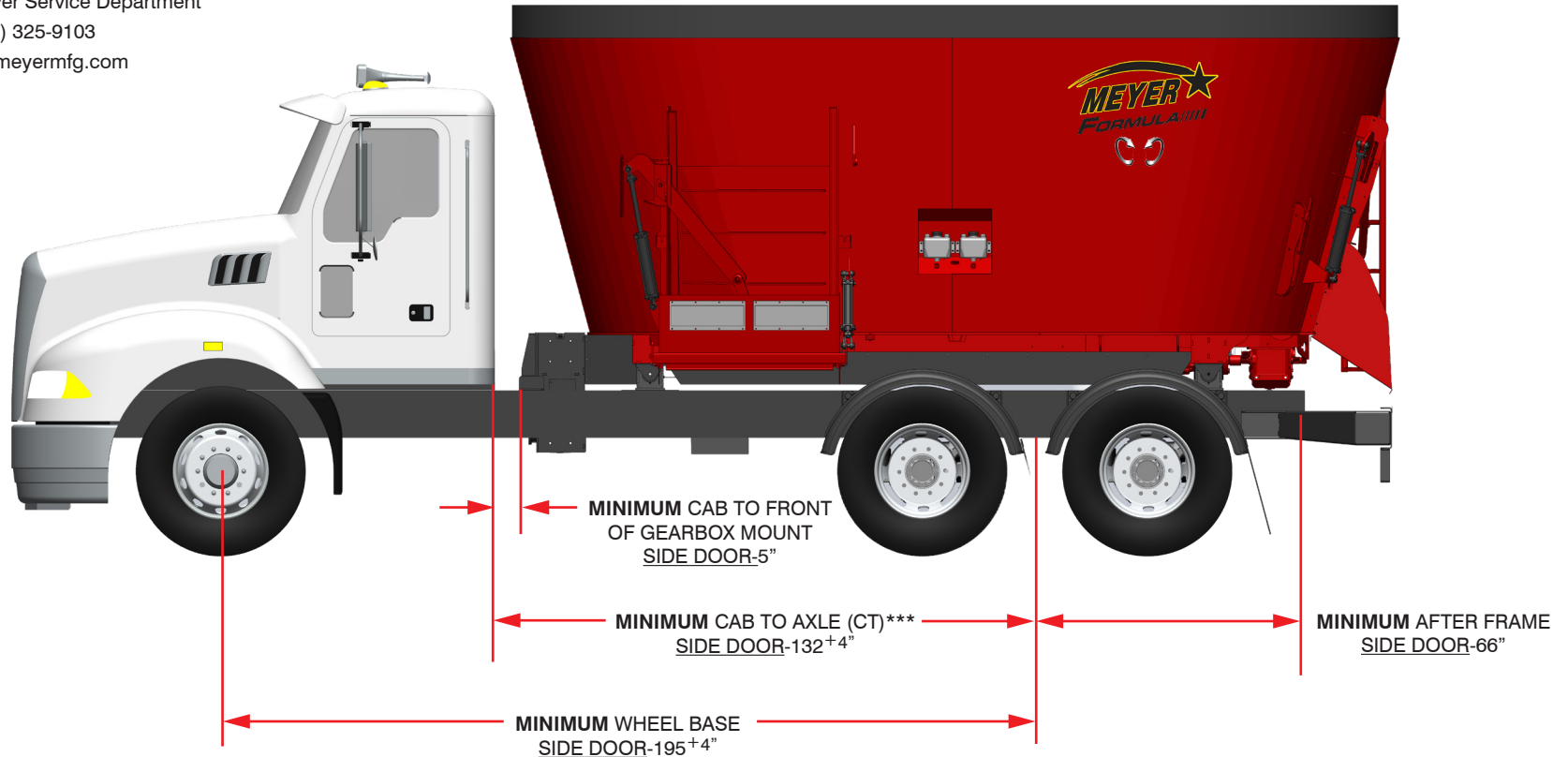

* MIN FRAME SECTION MODULUS refers to strength of frame based on 110,000 PSI yield strength

** PTO adapter must have bolt pattern and pilot to accept a 1410 series driveline, Spicer# 3-2-159

*** No braces, exhaust pipes, brackets, hardware, etc. behind cab and above frame rails, unless cab to axle (CT) dimension is taken from behind these features

THE LISTED DIMENSIONS REPRESENT OPTIMAL CONFIGURATIONS. INCREASING THE WHEEL BASE MAY NEGATIVELY IMPACT MANEUVERABILITY, INCREASE THE TURNING RADIUS, AND RESULT IN IMPROPER AXLE LOADING. MEYER MANUFACTURING ASSUMES NO RESPONSIBILITY FOR UNITS THAT ARE NOT CONFIGURED IN ACCORDANCE WITH THESE SPECIFICATIONS.

585/700 STOP-SHIFT TRUCK MOUNT SPECIFICATIONS



FORMULA III

Truck Specification Questions?

Contact the Meyer Service Department

(800) 325-9103

sales@meyermfg.com

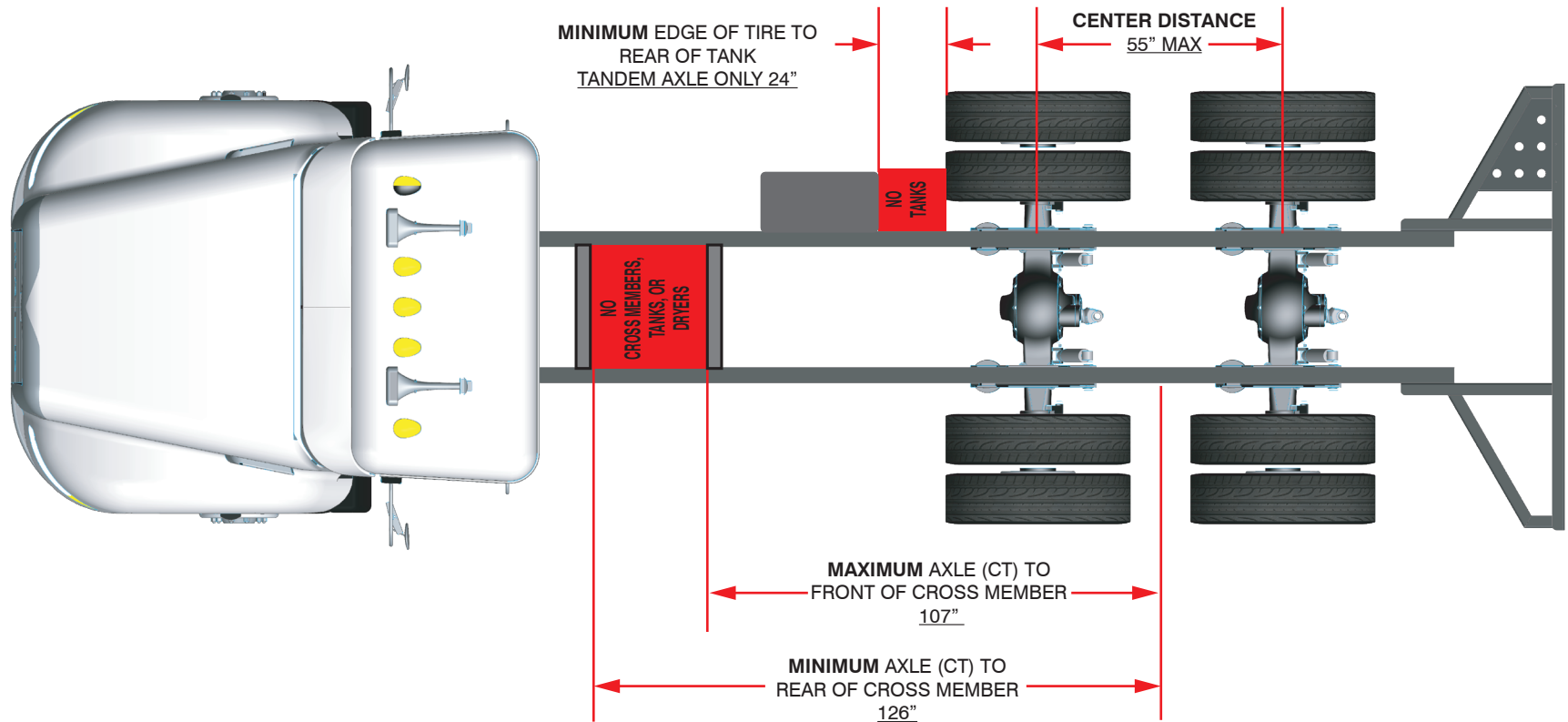

585/700 STOP-SHIFT TRUCK MOUNT SPECIFICATIONS



FORMULA III

Truck Specification Questions?

Contact the Meyer Service Department
(800) 325-9103
sales@meyermfg.com

Mandatory Truck Requirements:

- Cab should have bucket seats with space between seats open and available for mounting the mixer control console.
- Tail light 6-wire connection at the rear of drivers side frame using 6-pin weather-pack connector APTIV #12015799.
- Chelsea Smart Start PTO or equivalent is required

Truck Recommendations:

- Ground speed of 2- 3 mph at 1800 engine RPM is desired for feeding
 - Auxiliary Transmission recommended for trucks equipped with Allison automatic transmissions
 - Install Auxiliary Transmission (Drop Box) as far rearward as possible
- Radiator Options: Feedlot, Reverse Fan, Prescreen, Auxiliary Condenser etc.
- Throttle lock / cruise control at engine speed incremental up to 1800 RPM
- Wide mirrors
- Frame Splicing tapered and staggered (Talk to your truck shop)

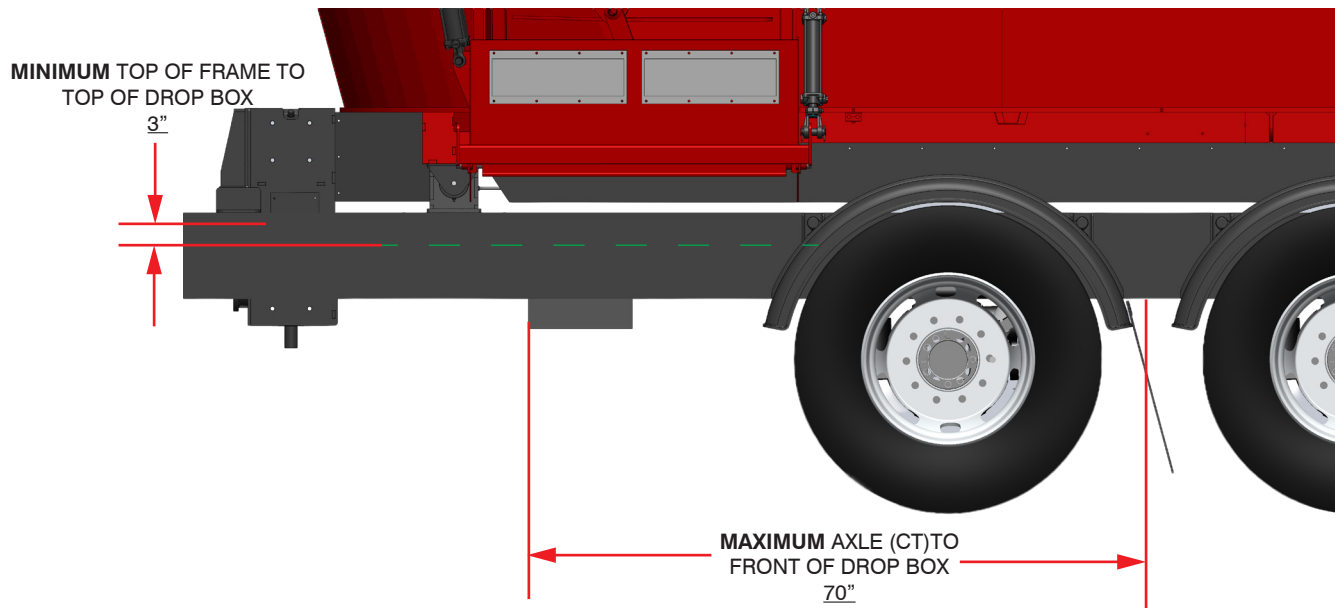

NOTE: IF TRUCK IS SUPPLIED BY THE CUSTOMER, IT IS THE RESPONSIBILITY OF THE CUSTOMER TO WORK WITH A KNOWLEDGEABLE TRUCK DEALER TO ENSURE ALL LOCAL AND STATE TRANSPORTATION LAWS WILL BE MET WHERE THE TRUCK IS TO BE OPERATED. IF TRUCK IS SUPPLIED BY A TRUCK DEALER, IT IS THEIR RESPONSIBILITY TO MAKE THE TRUCK LEGAL FOR ROAD USE BY ALL STATE AND LOCAL LAWS AFFECTING THE CUSTOMER. ALWAYS FOLLOW FEDERAL, STATE AND LOCAL LAWS FOR LIGHTING, MUD FLAPS, HEIGHT, WIDTH, WEIGHT AND OPERATION. OVER-WIDTH PERMITS MAY BE NECESSARY IN CERTAIN AREAS OF THE COUNTRY.

585/700 POWER-SHIFT TRUCK MOUNT SPECIFICATIONS



FORMULA III

Truck Specification Questions?

Contact the Meyer Service Department
 (800) 325-9103
 sales@meyermfg.com

MIXER MODEL	AXLE TYPE	MINIMUM GVWR	MINIMUM FRAME SECTION MODULUS*	MINIMUM FRONT/REAR	MINIMUM ENGINE HP	MINIMUM ENGINE DISPLACEMENT	MINIMUM TORQUE @ PTO ADAPTER**
F585-MA SIDE DOOR	SINGLE	45,000#	17	12,000# / 33,000#	300 HP	8 LITER	500 FT-LBS @ 100% PTO
F585-MA SIDE DOOR	TANDEM	52,000#	17	12,000# / 40,000#	300 HP	8 LITER	500 FT-LBS @ 100% PTO
F700-MA SIDE DOOR	TANDEM	54,000#	17	14,000# / 40,000#	300 HP	8 LITER	500 FT-LBS @ 100% PTO

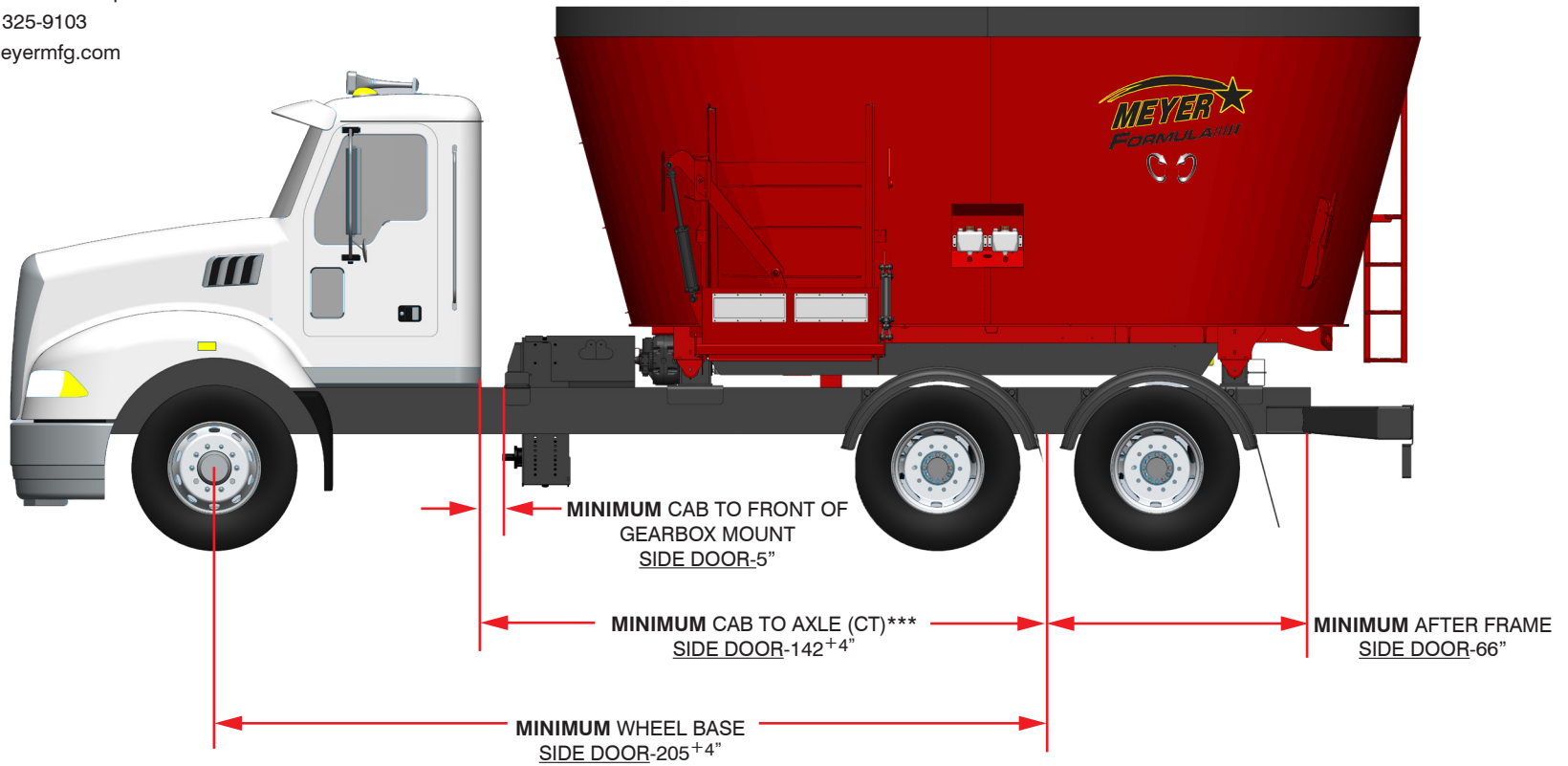

* MIN FRAME SECTION MODULUS refers to strength of frame based on 110,000 PSI yield strength

** PTO adapter must have bolt pattern and pilot to accept a 1410 series driveline, Spicer# 3-2-159

*** No braces, exhaust pipes, brackets, hardware, etc. behind cab and above frame rails, unless cab to axle (CT) dimension is taken from behind these features

THE LISTED DIMENSIONS REPRESENT OPTIMAL CONFIGURATIONS. INCREASING THE WHEEL BASE MAY NEGATIVELY IMPACT MANEUVERABILITY, INCREASE THE TURNING RADIUS, AND RESULT IN IMPROPER AXLE LOADING. MEYER MANUFACTURING ASSUMES NO RESPONSIBILITY FOR UNITS THAT ARE NOT CONFIGURED IN ACCORDANCE WITH THESE SPECIFICATIONS.

585/700 POWER-SHIFT TRUCK MOUNT SPECIFICATIONS



FORMULA IIII

Truck Specification Questions?

Contact the Meyer Service Department

(800) 325-9103

sales@meyermfg.com

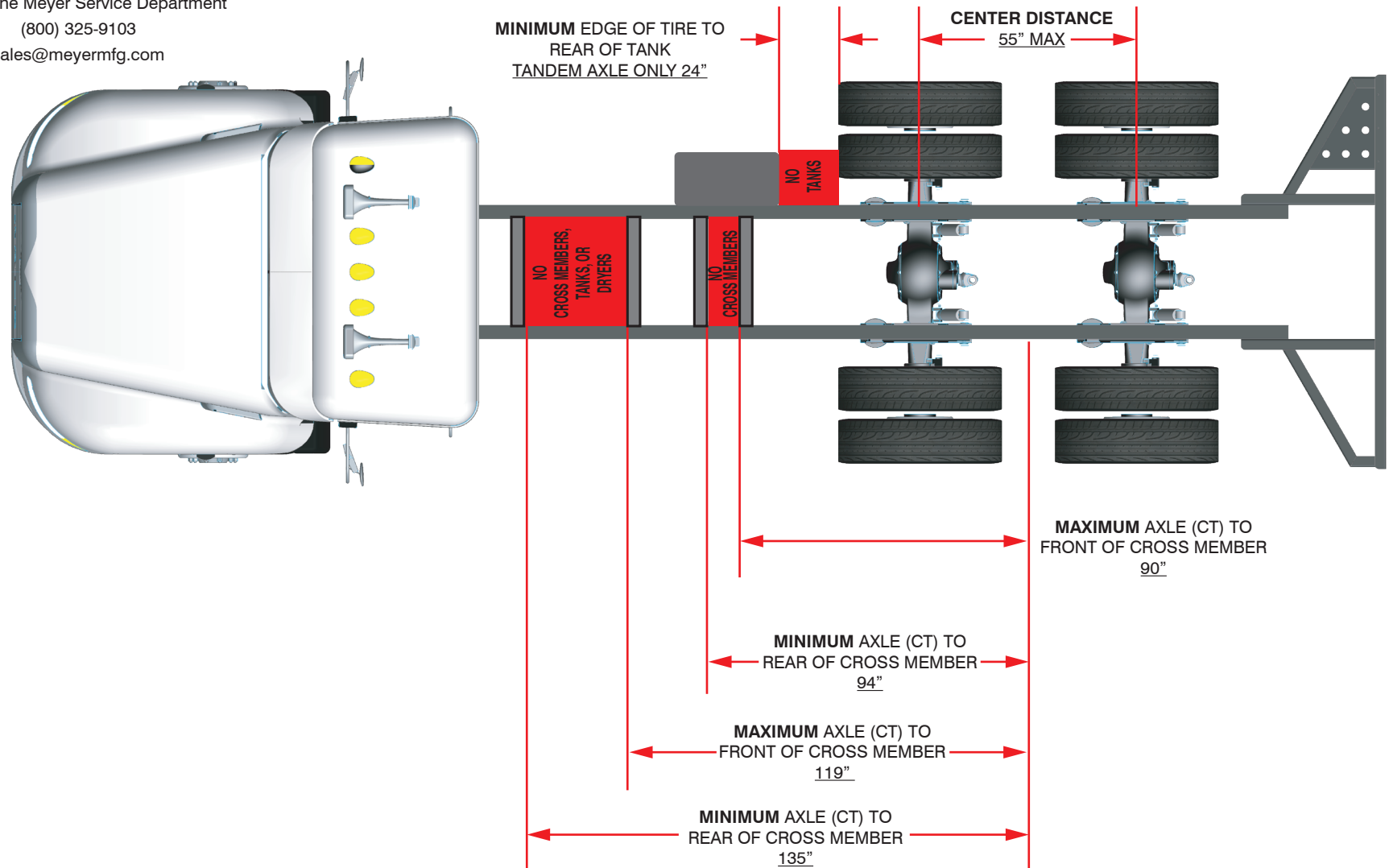

585/700 POWER-SHIFT TRUCK MOUNT SPECIFICATIONS



FORMULA IIII

Truck Specification Questions?

Contact the Meyer Service Department
(800) 325-9103
sales@meyermfg.com

Mandatory Truck Requirements:

- Cab should have bucket seats with space between seats open and available for mounting the mixer control console.
- Tail light 6-wire connection at the rear of drivers side frame using 6-pin weather-pack connector APTIV #12015799.
- Chelsea Smart Start PTO or equivalent is required

Truck Recommendations:

- Ground speed of 2- 3 mph at 1800 engine RPM is desired for feeding
 - Auxiliary Transmission recommended for trucks equipped with Allison automatic transmissions
 - Install Auxiliary Transmission (Drop Box) as far rearward as possible
- Radiator Options: Feedlot, Reverse Fan, Prescreen, Auxiliary Condenser etc.
- Throttle lock / cruise control at engine speed incremental up to 1800 RPM
- Wide mirrors
- Frame Splicing tapered and staggered (Talk to your truck shop)

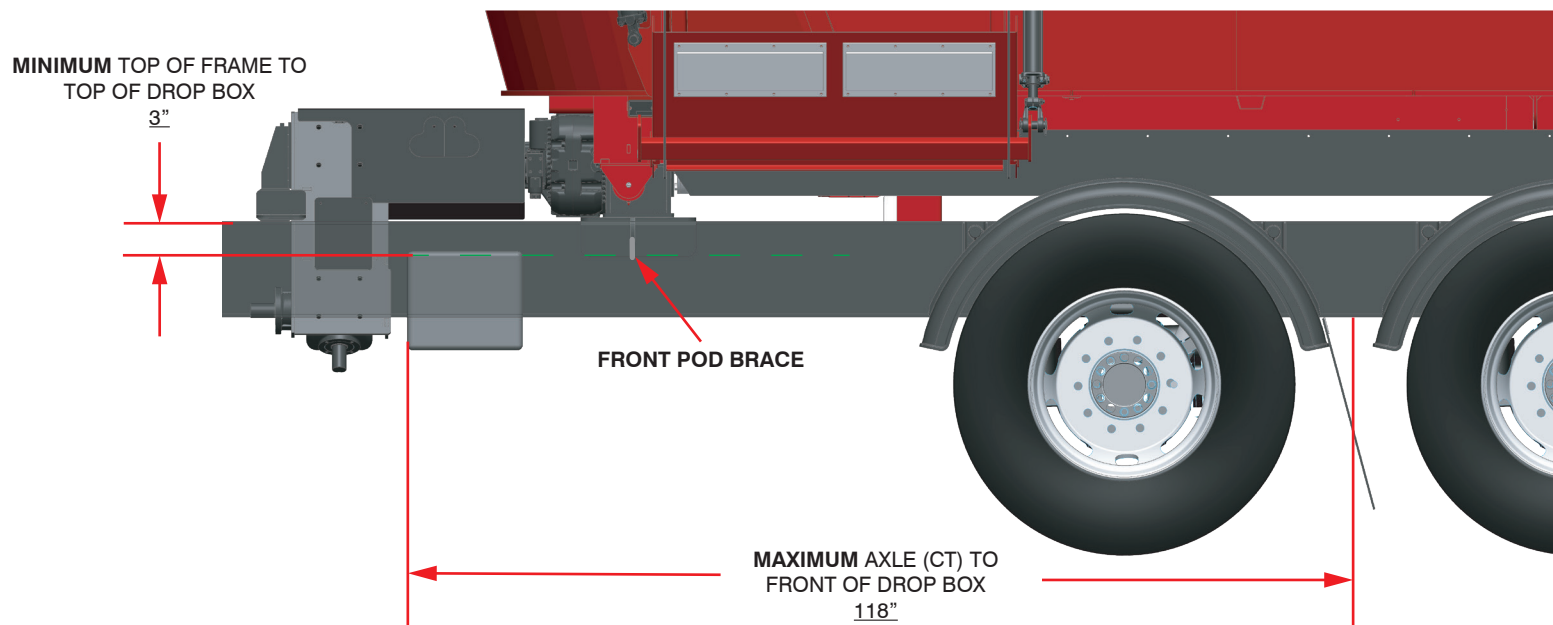

NOTE: IF TRUCK IS SUPPLIED BY THE CUSTOMER, IT IS THE RESPONSIBILITY OF THE CUSTOMER TO WORK WITH A KNOWLEDGEABLE TRUCK DEALER TO ENSURE ALL LOCAL AND STATE TRANSPORTATION LAWS WILL BE MET WHERE THE TRUCK IS TO BE OPERATED. IF TRUCK IS SUPPLIED BY A TRUCK DEALER, IT IS THEIR RESPONSIBILITY TO MAKE THE TRUCK LEGAL FOR ROAD USE BY ALL STATE AND LOCAL LAWS AFFECTING THE CUSTOMER. ALWAYS FOLLOW FEDERAL, STATE AND LOCAL LAWS FOR LIGHTING, MUD FLAPS, HEIGHT, WIDTH, WEIGHT AND OPERATION. OVER-WIDTH PERMITS MAY BE NECESSARY IN CERTAIN AREAS OF THE COUNTRY.